

THE RADIO AMATEUR'S
HANDBOOK
 * EIGHTEENTH EDITION * NINETEEN-FORTY-ONE *

Antennas	Pages 318-361	
Emergency and Portable	Pages 263-269	→
Frequency Modulation	Pages 402-414	→
Fundamentals	Pages 23-70	→
Keying	Pages 221-231	→
Measurements	Pages 245-262	→
Miscellaneous General Data	Pages 277-283	→
Miscellaneous Technical Data	Pages 22-70	→
Modulation	Pages 88-103	→
Modulator Construction	Pages 191-201	→
Modulator Data (Table)	Pages 94-98	→
Operating Practices	Pages 421-436	→
Power Supplies	Pages 174-190	→
Receiver Design	Pages 48-70	→
Receiver Construction	Pages 109-127	→
Receiver Tuning and Adjustment	Pages 128-137	→
Regulations	Pages 437-446	→
Speech Amplifier Data (Table)	Pages 94-96	→
Station Assembly	Pages 270-276	→
Transmitter Design	Pages 71-87	→
Transmitter Construction	Pages 138-173	→
Transmitter Adjustment ('Phone)	Pages 232-243	→
Tube Tables (Receiving)	Pages 289-304	→
Tube Tables (Transmitting)	Pages 303-317	→
U.H.F.	Pages 362-420	→
Workshop Practice	Pages 104-108	→
Index	Pages 545-552	→

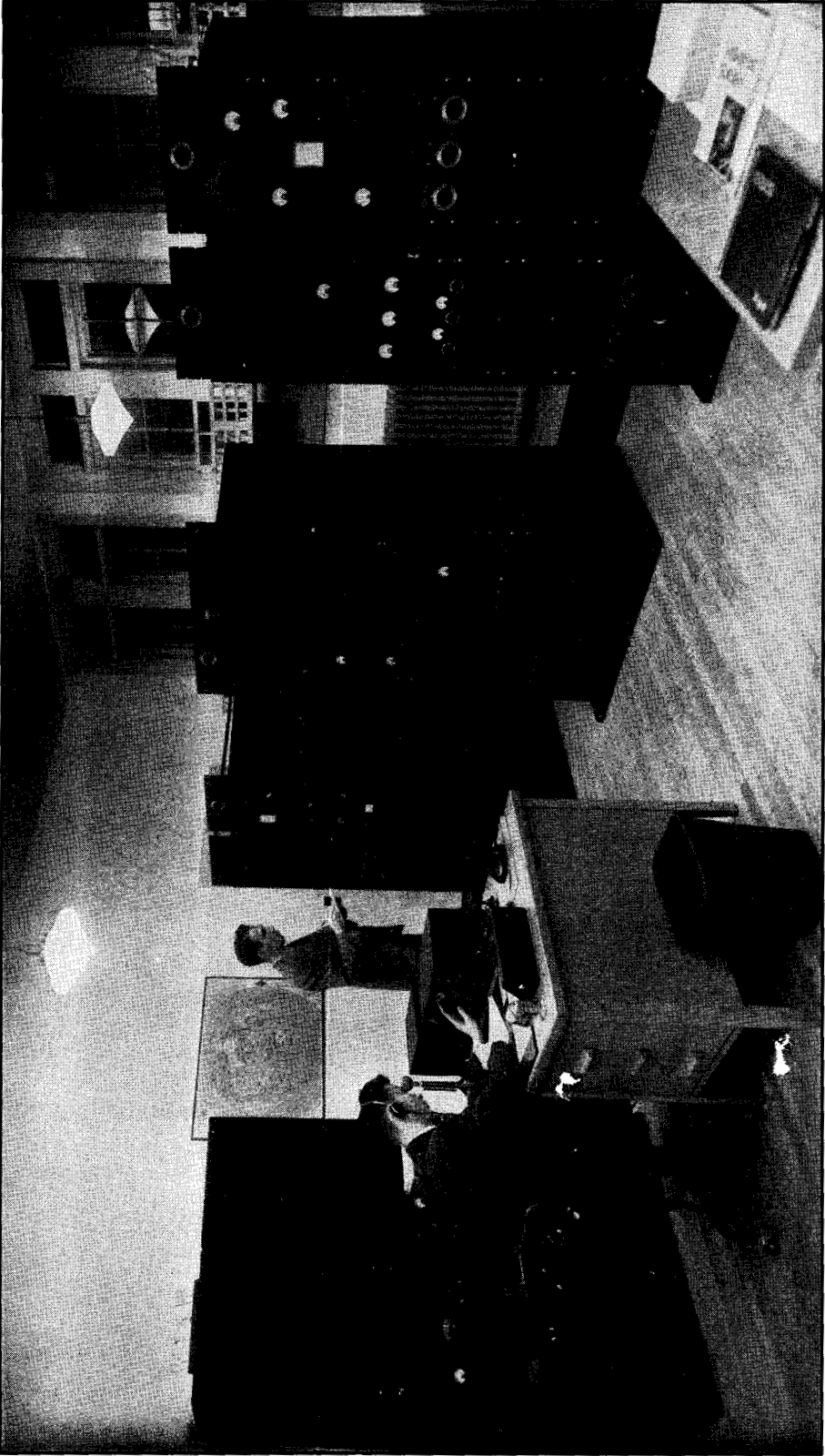

THE OPERATING ROOM AT THE MAXIM MEMORIAL STATION, WIAW, A.R.R.L. HEADQUARTERS

Separate 1-kw. transmitters are installed for each band. Voice transmissions on 1806, 3950, 14,237 kc. and 28,600 follow simultaneous telegraph messages to all amateurs sent on 1762.5, 3825, 7280, 14,254 kc. and 28,600 kc. at 7.30 and 11 p.m. CST. Operators "Hal" Bubb (seated) and "Geo" Hart (standing) are always ready for a call from any amateur

**THE RADIO AMATEUR'S
HANDBOOK
* EIGHTEENTH EDITION * NINETEEN-FORTY-ONE ***

BY THE HEADQUARTERS STAFF OF THE
AMERICAN RADIO RELAY LEAGUE



PUBLISHED BY THE
AMERICAN RADIO RELAY LEAGUE, INC.
WEST HARTFORD, CONNECTICUT

COPYRIGHT 1940 BY THE AMERICAN RADIO RELAY LEAGUE, INC.

Copyright secured under the Pan-American Convention.

All rights of translation reserved.



First Edition, November, 1926	5,000 copies
Second Edition, First Printing, January, 1927	5,000 copies
Second Edition, Second Printing, April, 1927	10,000 copies
Third Edition, First Printing, October, 1927	10,000 copies
Third Edition, Second Printing, April, 1928	10,000 copies
Fourth Edition, December, 1928	10,000 copies
Fifth Edition, May, 1929	10,000 copies
Sixth Edition, First Printing, November, 1929	10,000 copies
Sixth Edition, Second Printing, March, 1930	10,000 copies
Sixth Edition, Third Printing, June, 1930	7,000 copies
Seventh Edition, October, 1930	25,000 copies
Eighth Edition, April, 1931	25,000 copies
Ninth Edition, First Printing, January, 1932	30,000 copies
Ninth Edition, Second Printing, September, 1932	10,000 copies
Tenth Edition, First Printing, January, 1933	30,000 copies
Tenth Edition, Second Printing, July, 1933	8,750 copies
Eleventh Edition, First Printing, January, 1934	30,000 copies
Eleventh Edition, Second Printing, May, 1934	13,000 copies
Twelfth Edition, First Printing, November, 1934	40,000 copies
Twelfth Edition, Second Printing, July, 1935	8,000 copies
Thirteenth Edition, First Printing, October, 1935	40,000 copies
Thirteenth Edition, Second Printing, February, 1936	33,200 copies
Fourteenth Edition, First Printing, October, 1936	40,000 copies
Fourteenth Edition, Second Printing, February, 1937	28,300 copies
Fifteenth Edition, First Printing, October, 1937	40,000 copies
Fifteenth Edition, Second Printing, January, 1938	25,000 copies
Sixteenth Edition, November, 1938	60,000 copies
Seventeenth Edition, First Printing, November, 1939	40,000 copies
Seventeenth Edition, Second Printing, January, 1940	25,000 copies
Eighteenth Edition, First Printing, November, 1940	40,000 copies
Eighteenth Edition, Second Printing, January, 1941	20,000 copies
Eighteenth Edition, Third Printing, June, 1941	10,000 copies

PRINTED IN U. S. A. BY
THE RUMFORD PRESS
CONCORD, NEW HAMPSHIRE

FOREWORD

IN PRESENTING for 1941 the eighteenth edition of *The Radio Amateur's Handbook* the publishers again express the hope that it will be found as helpful as previous editions and will enjoy as whole-hearted a reception at the hands of the amateur fraternity.

From modest beginnings in 1926 the *Handbook* has had an inspiring success, running now to eighteen editions in thirty printings and a total distribution well over six hundred thousand copies. Its fame has echoed around the world. Schools and technical classes have adopted it as a text; quantity orders have come from many a foreign land. But most important of all, it is the right-hand guide of practical amateurs in every country of the globe. This success derives in considerable measure from the splendid coöperation we have always received from practicing amateurs everywhere, for which we remain grateful.

Devoted to a fast-moving and progressive science, it is only natural that throughout its life the *Handbook* should have required sweeping and virtually continuous modification. Since the very beginning a strenuous attempt has been made to keep the book as up to date, as accurate and as reliable as is humanly possible. A studious effort has been made to restrict the material to modern, sound and well-tried practice. Having always had somewhat the character of an annual review of time-tried and proven methods in apparatus construction and operation, the *Handbook* has never provided a place for freaky circuits or methods. As any practicing amateur is well aware, there is an almost infinite number of ways of accomplishing a given result in his station — some good, some poor, many indifferent. Our editorial task has therefore been basically one of selecting. It has been necessary to eliminate from the enormous wealth of ideas on technique, methods and procedure, all those that have not proved themselves by successful application in practice.

For many editions back, the annual revision of the *Handbook* has been a sort of family affair of the headquarters staff of the American Radio Relay League at West Hartford. Most of the technically-skilled specialists on the League's staff, men who have earned their spurs in amateur radio, have participated in its revision. The present edition has seen a general rewriting and the addition of nearly two hundred new illustrations, while dozens of new pieces of apparatus were specially designed and constructed — and tested! Prepared under the general technical editorship of Mr. George Grammer, *QST's* technical editor, and with major contributions by him, the present work also represents many months of labor on the part of Messrs. Donald H. Mix and Byron Goodman, *QST's* assistant technical editors; Mr. Clinton B. DeSoto, assistant secretary of the League; and Mr. Vernon Chambers, in charge of *QST's* technical information service. The station-operating material of course is contributed by the League's communications manager, Mr. Francis E. Handy. The actual production of the book has been on the broad shoulders of Mr. Clark C. Rodimon, *QST's* managing editor.

In this edition we retain last year's plan of rearranging the material for the greatest benefit of the various classes of *Handbook* users, and a few words of explanation may be in order. First, from a reference to the contents page it will be seen that the book is divided into sections: introductory, principles, the construction and use of equipment, antennas, and so on. Within these sections there continues to be a more extensive subdivision into chapters than

in the past, for the purpose of segregating the material in which various groups of users will be more particularly interested. For example, the elements of a lecture or study course in radio will be found by taking Chapters 3 to 6, 11, 17, 21 to 24, and 26. Design information particularly valuable to amateurs who plan their own equipment is given in Chapters 4 to 6, and 20. Adjustment and "trouble-shooting" have been segregated for transmitters, receivers and 'phone, respectively, in Chapters 9, 14 and 16, to make these important treatments more readily available not only for those who are building new equipment but for those who already have satisfactory apparatus. At the end of each chapter on the construction of equipment there is a bibliography of articles in *QST* in which will be found more extensive descriptions of some of the pieces of apparatus described in this edition. References to these bibliographies will be found frequently in the text and take such a form as (*Bib. 5*), which means that the fifth item in the bibliography at the end of that particular chapter will give a reference to a *QST* article describing the particular piece of gear in somewhat greater detail. It should perhaps be pointed out that, to facilitate reference, the illustrations herein are serially numbered in each chapter and with the first digit indicating the chapter number. Thus, Fig. 812 can be readily located as the twelfth illustration in Chapter 8. Finally it should be mentioned (because many amateurs do not seem aware of it!) that this *Handbook* has, at the end of its reading pages, a comprehensive and carefully-prepared index, which will lead the reader quickly to the treatment of a subject of particular interest.

One feature of the *Handbook* which has been growing steadily in importance is the quite extensive catalog advertising. We recognize that it is generally not regarded as good form to make editorial reference even to the existence of advertising, but this case we believe to be different. To be truly comprehensive as a handbook — to fill all the functions one visualizes with the word "handbook" — this book must bring the reader data and specifications on the manufactured products which are the raw material of amateur radio. Our manufacturers have collaborated with us in this purpose by presenting here not mere advertising but catalog technical data. The amateur constructor and experimenter will find it convenient to possess in such juxtaposition both the constructional guidance he seeks and the needed data on available equipment, since both are necessary ingredients of the complete standard manual of amateur high-frequency communication.

It is but natural that we here shall all feel very happy if this edition of the *Handbook* brings as much assistance and inspiration to amateurs and would-be amateurs as have its predecessors.

KENNETH B. WARNER
Managing Secretary, A.R.R.L.

WEST HARTFORD, CONN.
November, 1940

CONTENTS

Frontispiece:

HIRAM PERCY MAXIM MEMORIAL STATION, W1AW
THE AMATEUR — HIS CODE OF ETHICS

INTRODUCTION

<i>Chapter 1</i>	Story of Amateur Radio	9
<i>Chapter 2</i>	Getting Started	15

PRINCIPLES AND DESIGN

<i>Chapter 3</i>	Electrical and Radio Fundamentals	22
<i>Chapter 4</i>	Reception of Radio Signals	48
<i>Chapter 5</i>	Transmitter Design	71
<i>Chapter 6</i>	Modulation	88

CONSTRUCTION AND ADJUSTMENT

<i>Chapter 7</i>	Workshop Practice	104
<i>Chapter 8</i>	Construction of Receivers	109
<i>Chapter 9</i>	Tuning and Adjusting Receivers	128
<i>Chapter 10</i>	Construction of Transmitters	138
<i>Chapter 11</i>	Power Supply	174
<i>Chapter 12</i>	Modulation Equipment	191
<i>Chapter 13</i>	Complete Transmitters	202
<i>Chapter 14</i>	Transmitter Adjustment	210
<i>Chapter 15</i>	Keying and B.C.I. Elimination	221
<i>Chapter 16</i>	Adjustment of 'Phone Transmitters	232
<i>Chapter 17</i>	Measurements and Measuring Equipment	245
<i>Chapter 18</i>	Emergency and Portable	263
<i>Chapter 19</i>	Station Assembly	270
<i>Chapter 20</i>	Tube Characteristics and Miscellaneous Data	277

ANTENNAS

<i>Chapter 21</i>	Antenna Fundamentals	318
<i>Chapter 22</i>	R.F. Transmission Lines	325
<i>Chapter 23</i>	Long-Wire Antennas	339
<i>Chapter 24</i>	Multi-Element Directive Systems	348
<i>Chapter 25</i>	Antenna Construction	355

ULTRA-HIGH FREQUENCIES

<i>Chapter 26</i>	Introduction to U.H.F.	362
<i>Chapter 27</i>	U.H.F. Receiving Equipment	364
<i>Chapter 28</i>	Transmitters and Transceivers for U.H.F.	380
<i>Chapter 29</i>	Frequency Modulation	402
<i>Chapter 30</i>	Antennas for the U.H.F.	415

OPERATING AND TRAFFIC HANDLING

<i>Chapter 31</i>	Operating the Station	421
<i>Chapter 32</i>	Regulations	437
INDEX	545

THE AMATEUR'S CODE

- 1** *The Amateur is Gentlemanly.* He never knowingly uses the air for his own amusement in such a way as to lessen the pleasure of others. He abides by the pledges given by the A.R.R.L. in his behalf to the public and the Government.
- 2** *The Amateur is Loyal.* He owes his amateur radio to the American Radio Relay League, and he offers it his unswerving loyalty.
- 3** *The Amateur is Progressive.* He keeps his station abreast of science. It is built well and efficiently. His operating practice is clean and regular.
- 4** *The Amateur is Friendly.* Slow and patient sending when requested, friendly advice and counsel to the beginner, kindly assistance and coöperation for the broadcast listener; these are marks of the amateur spirit.
- 5** *The Amateur is Balanced.* Radio is his hobby. He never allows it to interfere with any of the duties he owes to his home, his job, his school, or his community.
- 6** *The Amateur is Patriotic.* His knowledge and his station are always ready for the service of his country and his community.

Story of Amateur Radio

How It Started—The Part Played by The A.R.R.L.

AMATEUR radio represents, to some seventy thousand people, the most satisfying, most exciting of all hobbies. Over 50,000 of these enthusiasts are located in the United States and Canada, for it is this continent which gave birth to the movement and which has ever since represented its stronghold.

When radio broadcasting was first introduced to the public some years ago, it instantly caught the fancy of millions of people all over the world. Why? Because it fired their imagination — because it thrilled them to tune in on a program direct from some distant point, to hear speech and music that was at that moment being transmitted from a city hundreds and even thousands of miles away. To be sure there was also a certain amount of entertainment value, and it is true that as the years have passed this phase has become paramount in the minds of most listeners; yet the thrill of "DX" is still a major factor in the minds of hundreds of thousands of people, as witness the present popularity of international short wave reception of foreign programs.

That keen satisfaction of hearing a distant station is basic with the radio amateur but it has long since been superseded by an even greater lure, and that is the thrill of *talking* with these distant points! On one side of your radio amateur's table is his short-wave receiver; on the other side is his private (and usually homemade) short-wave transmitter, ready at the throw of a switch to be used in calling and "working" other amateurs in the United States, in Canada, Europe, Australia, every corner of the globe!* Even a low-power transmitter makes it possible to develop friendships in every State in the Union. Of course, it is not to be expected that the first contacts will necessarily be with foreign amateurs. Experience in adjusting the simple transmitter, in using the right frequency band at the right time of day when foreign stations are on the air, and practice in operating are necessary before communication will be enjoyed with amateurs of other nationalities. But patience and experience are the sole prerequisites; neither high power nor expensive equipment is required.

* Because of the current international situation, communication by U. S. amateurs with foreign countries is temporarily forbidden.

Nor does the personal enjoyment that comes from amateur radio constitute its only benefit. There is the enduring satisfaction that comes from doing things with the apparatus put together by one's own skill. The process of designing and constructing radio equipment develops real engineering ability. Operating an amateur station with even the simplest equipment likewise develops operating proficiency and skill. Many an engineer, operator and executive in the commercial radio field got his practical background and much of his training from his amateur work. So, in addition to the advantages of amateur radio as a hobby, the value of systematic amateur work to a student of almost every branch of radio cannot well be overlooked. An increasing number of radio services, each expanding in itself, require additional personnel — technicians, operators, inspectors, engineers and executives — and in every field a background of amateur experience is regarded as valuable.

Amateur radio is as old as the art itself.

There were amateurs before the present century. Shortly after the late Guglielmo Marconi had astounded the world with his first experiments proving that telegraph messages actually could be sent between distant points without wires, they were attempting to duplicate his results. Marconi himself was probably the first amateur — indeed, the distinguished inventor so liked to style himself. But amateur radio as it has come to be known was born when private citizens first saw in the new marvel a means for personal communication with others and set about learning enough of the new art to build a homemade station.

Amateur radio's subsequent development may be divided into two periods: pre-war and post-war.

Pre-war amateur radio bore little resemblance to the art as it exists to-day, except in principle. The equipment, both transmitting and receiving, was of a type now long obsolete. The range of even the highest-powered transmitters, under the most favorable conditions, would be scoffed at by the rankest beginner to-day. No United States amateur had ever heard the signals of a foreign amateur, nor

The Radio Amateur's Handbook

had any foreigner ever reported hearing an American. The oceans were a wall of silence, impenetrable, isolating us from every signal abroad. Even transcontinental DX was accomplished in relays. "Short waves" meant 200 meters; the entire wavelength spectrum below 200 meters was a vast silence — no signal ever disturbed it. Years were to pass before its phenomenal possibilities were to be suspected.

Yet the period was notable for a number of accomplishments. It saw the number of amateurs in the United States increase to approximately 4,000 by 1917. It witnessed the first appearance of radio laws, licensing, wavelength specifications for the various services. ("Amateurs? — oh, yes — well, stick 'em on 200 meters: it's no good for anything; they'll never get out of their own back yards with it.") It saw an increase in the range of amateur stations to such unheard-of distances as 500 and, in some cases, even 1,000 miles, with U. S. amateurs beginning to wonder, just before the war, if there were amateurs in other countries across the seas and if — daring thought! — it might some day be possible to span the Atlantic with 200-meter equipment. Because all long-distance messages had to be relayed, this period saw relaying developed to a fine art — and what a priceless accomplishment that ability turned out to be later when the government suddenly needed dozens and hundreds of skilled operators for war service! Most important of all, the pre-war period witnessed the birth of the American Radio Relay League, the amateur organization whose fame was to travel to all parts of the world and whose name was to be virtually synonymous with subsequent amateur progress and short-wave development. Conceived and formed by the famous inventor and amateur, the late Hiram Percy Maxim, it was formally launched in early 1914 and was just beginning to exert its full force in amateur activities when the United States declared war and by that act sounded the knell for amateur radio for the next two and one-half years. By presidential direction every amateur station was dismantled. Within a few months three-fourths of the amateurs of the country were serving with the armed forces of the United States as operators and instructors.

Few amateurs to-day realize that the war not only marked the close of the first phase of amateur development but came very near marking its end for all time. The fate of amateur radio was in the balance in the days immediately following declaration of the Armistice, in 1918. The government, having had a taste of supreme authority over all communications in wartime, was more than half inclined to keep it; indeed, the war had not been ended a month

before Congress was considering legislation that would have made it impossible for the amateur radio of old ever to be resumed. President Maxim rushed to Washington, pleaded, argued; the bill was defeated. But there was still no amateur radio; the war ban continued in effect. Repeated representations to Washington met only with silence; it was to be nearly a year before licenses were again issued.

In the meantime, however, there was much to be done. Three-fourths of the former amateurs had gone to France; many of them would never come back. Would those who had returned be interested, now, in such things as amateur radio? Mr. Maxim determined to find out and called a meeting of such members of the Board of Directors of the League as he could locate. Eleven men, several still in uniform, met in New York and took stock of the situation. It wasn't very encouraging: amateur radio still banned by law, former members of the League scattered no one knew where, no League, no membership, no funds. But those eleven men financed the publication of a notice to all the former amateurs that could be located, hired Kenneth B. Warner as the League's first paid secretary, floated a bond issue among old League members to obtain money for immediate running expenses, bought the magazine *QST* to be the League's official organ, and dunned officialdom until the war-time ban was lifted and amateur radio resumed again. Even before the ban was lifted, in October, 1919, old-timers all over the country were flocking back to the League, renewing friendships, planning for the future. When licensing was resumed there was a headlong rush to get back on the air.

From the start, however, post-war amateur radio took on new aspects. War-time pressure had stimulated technical development in radio. There were new types of equipment. The vacuum tube was being used for both receiving and transmitting. Amateurs immediately adapted the new apparatus to 200-meter work. Ranges promptly increased; soon it was possible to bridge the continent with but one intermediate relay. Shortly thereafter stations on one coast were hearing those on the other direct!

These developments had an inevitable result. Watching DX come to represent 1,000 miles, then 1,500 and then 2,000, amateurs began to dream of transatlantic work. Could they get across? In December, 1921, the A.R.R.L. sent abroad one of its most prominent amateurs, Paul Godley, with the best amateur receiving equipment available. Tests were run, and thirty American amateur stations were heard in Europe! The news electrified the amateur world. In 1922 another transatlantic test was carried out; this time 315 American calls

Story of Amateur Radio

were logged by European amateurs and, what was more, one French and two British stations were heard on this side.

Everything now was centered on one objective: two-way communication across the Atlantic by amateur radio! It *must* be possible — but somehow they couldn't quite make it. Further increases in power were out of the question; many amateurs already were using the legal maximum of one kilowatt. Better receivers? They already had the superheterodyne; it didn't seem possible to make any very great advance in that direction.

How about trying another wavelength, then, they asked? What about those wavelengths *below* 200 meters? The engineering world said they were worthless — but then, that had been said about 200 meters, too. There have been many wrong guesses in history. In 1922 the assistant technical editor of *QST* (Phelps, now W9BP) carried on tests between Hartford and Boston on 130 meters. The results were encouraging. Early in 1923 the A.R.R.L. sponsored a series of organized tests on wavelengths down to 90 meters and it was noted that as the wavelength dropped the reported results were better. A growing excitement began to filter into the amateur ranks.

Finally, in November, 1923, after some months of careful preparation, two-way amateur communication across the Atlantic became a reality, when Schnell, 1MO (now W9UZ), and Reinartz, 1XAM (now W3IBS), worked for several hours with Deloy, 8AB, in France, all three stations using a wavelength of 110 meters! Additional stations dropped down to 100 meters and found that they, too, could easily work two-way across the Atlantic. The exodus from the 200-meter region started.

By 1924 the entire radio world was agog and dozens of commercial companies were rushing stations into the 100-meter region. Chaos threatened, until the first of a series of radio conferences partitioned off various bands of frequencies for all the different services clamoring for assignments. Although thought was still centered in 100 meters, League officials at the first of these conferences, in 1924, came to the conclusion that the surface had probably only been scratched, and wisely obtained amateur bands not only at 80 meters, but at 40 and 20 and 10 and even 5 meters.

Many amateurs promptly jumped down to the 40-meter band. A pretty low wavelength, to be sure, but you never could tell about these short waves. Forty was given a try and responded by enabling two-way communication with Australia, New Zealand and South Africa.

How about 20? It immediately showed entirely unexpected possibilities by enabling an east-coast amateur to communicate with

another on the west coast, direct, at high noon. The dream of amateur radio — daylight DX! — had come true.

From that time to the present represents a period of unparalleled accomplishment. The short waves proved a veritable gold mine. Country after country came on the air, until the confusion became so great that it was necessary to devise a system of international intermediates in order to distinguish the nationality of calls. The League began issuing what are known as WAC certificates to stations proving that they had worked all the continents. Over five thousand such certificates have been issued. Representatives of the A.R.R.L. went to Paris and deliberated with the amateur representatives of twenty-two other nations. On April 17, 1925, this conference formed the International Amateur Radio Union — a federation of national amateur societies. The amateur as a type is the same the world over.

Nor has experimental development been lost sight of in the enthusiasm incident to international amateur communication. The experimentally-minded amateur is constantly at work conducting tests in new frequency bands, devising improved apparatus for amateur receiving and transmitting, learning how to operate two and three and even four stations where previously there was room enough for only one.

In particular, the amateur experimenter presses on to the development of the higher frequencies represented by the wavelengths below 10 meters, territory only a few years ago regarded even by most amateurs as comparatively unprofitable operating ground.

The amateur's experience with five meters is especially representative of his initiative and resourcefulness, and his ability to make the most of what is at hand. In 1924 first amateur experiments in the vicinity of 56 Mc. indicated the band to be practically worthless for distance work; signals at such frequencies appeared capable of being heard only to "horizon range." But the amateur turns even such apparent disadvantages to use. If not suitable for long-distance work, at least the band was ideal for "short-haul" communication. Beginning in 1931, then, there was tremendous activity in 56-Mc. work by hundreds of amateurs all over the country, and a complete new line of transmitters and receivers was developed to meet the special conditions incident to communicating at these ultra-high frequencies. In 1934 additional impetus was given to this band when experiments by the A.R.R.L. with directive antennas resulted in remarkably consistent two-way communication over distances of more than 100 miles, without the aid of "hilltop" locations. While atmospheric con-

The Radio Amateur's Handbook

ditions appear to have a great deal to do with 5-meter DX, many thousands of amateurs are now spending much of their time in the 56-Mc. region, some having worked as many as four or five hundred different stations on that band at distances up to several hundred miles. Recently the radio world has been astounded by conditions whereby transcontinental contacts have been made on five meters, with hundreds of contacts over a thousand miles or so. To-day's concept of u.h.f. propagation was developed almost entirely through amateur research.

Most of the technical developments in amateur radio have come from the amateur ranks. Many of these developments represent valuable contributions to the art, and the articles about them are as widely read in professional circles as by amateurs. At a time when only a few broadcast engineers in the country knew what was meant by "100% modulation" the technical staff of the A.R.R.L. was publishing articles in *QST* urging amateur 'phones to embrace it and showing them how to do it. When interest quickened in five-meter work, and experiments showed that the ordinary regenerative receiver was practically worthless for such wavelengths, it was the A.R.R.L. that developed practical super-regenerative receivers as the solution to the receiver problem. From the League's laboratory, too, came in 1932, the single-signal superheterodyne — the world's most advanced high-frequency radiotelegraph receiver. In 1934 the commercial production of r.f. power pentodes came as a result of the A.R.R.L. Hq. technical staff's urging and demonstration of their advantages. In 1936 the "noise-silencer" circuit for superheterodynes was developed, permitting for the first time satisfactory high-frequency reception through the more common forms of man-made electrical interference. During 1938 the use of transmitters whose frequency could be changed by a continuous panel control became common, along with improved directive antennas.

Amateur radio is one of the finest of hobbies, but this fact alone would hardly merit such whole-hearted support as was given it by the United States government at recent international conferences. There must be other reasons to justify such backing. One of these is a thorough appreciation by the Army and Navy of the value of the amateur as a source of skilled radio personnel in time of war. The other is best described as "public service."

We have already seen 3,500 amateurs contributing their skill and ability to the American cause in the Great War. After the war it was only natural that cordial relations should prevail between the Army and Navy and the amateur. Several things occurred in the next few years to strengthen these relations. In

1924, when the U. S. dirigible *Shenandoah* made a tour of the country, amateurs provided continuous contact between the big ship and the ground. In 1925 when the United States battle fleet made a cruise to Australia and the Navy wished to test out short-wave apparatus for future communication purposes, it was the League's Traffic Manager who was in complete charge of an experimental high-frequency set on the U.S.S. *Seattle*.

Definite friendly relations between the amateur and the armed forces of the Government were cemented in 1925. In this year both the Army and the Navy came to the League with proposals for amateur coöperation. The radio Naval Reserve and the Army-Amateur Net are the outgrowth of these proposals.

The public service record of the amateur is a brilliant one. These services can be roughly divided into two classes: emergencies and expeditions. It is regrettable that space limitations preclude detailed mention of amateur work in both these classes, for the stories constitute high-lights of amateur accomplishment.

Since 1913, amateur radio has been the principal, and in many cases the only, means of outside communication in more than one hundred storm, flood and earthquake emergencies in this country. Among the most noteworthy were the Florida hurricanes of 1926, 1928 and 1935, the Mississippi and New England floods of 1927 and the California dam break of 1928. During 1931 there were the New Zealand and Nicaraguan earthquakes, and in 1932 floods in California and Texas. Outstanding in 1933 was the earthquake in southern California. In 1934 further floods in California and Oklahoma resulted in notable amateur coöperation. The 1936 eastern states flood, the 1937 Ohio River valley flood, and the 1938 southern California flood and Long Island-New England hurricane disaster saw the greatest emergency effort ever performed by amateurs. In all these and many others, amateur radio played a major rôle in the rescue work and amateurs earned worldwide commendation for their resourcefulness in effecting communication where all other means failed.

During 1938 the A.R.R.L. inaugurated its emergency preparedness program, providing for the appointment of regional and local Emergency Coördinators to organize amateur facilities and establish liaison with other agencies. This was in addition to the registration of personnel and equipment in the Emergency Corps. A comprehensive program of coöperation with the Red Cross, Western Union and others was put into effect.

Amateur coöperation with expeditions goes back to 1923, when a League member, Don Mix of Bristol, Conn., accompanied MacMillan to the Arctic on the schooner *Bowdoin* in

Story of Amateur Radio

charge of an amateur set. Amateurs in Canada and the United States provided the home contact. The success of this venture was such that other explorers made inquiry of the League regarding similar arrangements for their journeys. In 1924 another expedition secured amateur cooperation; in 1925 there were three, and by 1928 the figure had risen to nine for that year alone. Each year since then has seen League headquarters in receipt of requests for such service, until now a total of perhaps two hundred voyages and expeditions have been thus assisted. To-day practically no exploring trip starts from this country to remote parts of the world without making arrangements to keep in contact through the medium of amateur radio.

Emergency relief, expeditionary contact, experimental work and countless instances of other forms of public service — rendered, as they always have been and always will be, without hope or expectation of material reward — have made amateur radio an integral part of our national life.

The American Radio Relay League

THE American Radio Relay League is to-day not only the spokesman for amateur radio in this country but it is the largest amateur organization in the world. It is strictly of, by and for amateurs, is non-commercial and has no stockholders. The members of the League are the owners of the A.R.R.L. and *QST*.

The League is organized to represent the amateur in legislative matters. It is pledged to promote interest in two-way amateur communication and experimentation. It is interested in the relaying of messages by amateur radio. It is concerned with the advancement of the radio art. It stands for the maintenance of fraternalism and a high standard of conduct. One of its principal purposes is to keep amateur activities so well conducted that the amateur will continue to justify his existence. As an example of this might be cited the action of the League in sponsoring the establishment of a system of Standard Frequency Stations throughout the United States.

The operating territory of the League is divided into fourteen United States and six Canadian divisions. The affairs of the League are managed by a Board of Directors. One director is elected every two years by the membership of each United States division, and a Canadian General Manager is elected every two years by the Canadian membership. These directors then choose the president and vice-president, who are also directors, of course. No one commercially engaged in selling or manufacturing radio apparatus or literature can be a member of the Board or an officer of the League.

The president, vice-president, secretary, treasurer and communications manager of the League are elected or appointed by the Board of Directors. These officers constitute an Executive Committee which, under certain restrictions, decides how to apply Board policies to matters arising between Board meetings.

The League owns and publishes the magazine *QST*. *QST* goes to all members of the League each month. It acts as a monthly bulletin of the League's organized activities. It serves as a medium for the exchange of ideas. It fosters amateur spirit. Its technical articles are renowned. *QST* has grown to be the "amateur's bible" as well as one of the foremost radio magazines in the world. The profits *QST* makes are used in supporting League activities. Membership dues to the League include a subscription to *QST* for the same period.

The extensive field organization of the Communications Department coordinates operating activities throughout North America.

Headquarters

FROM the humble beginnings recounted in this story of amateur radio, League headquarters has grown until now it occupies an entire office building and employs nearly forty people.

Members of the League are entitled to write to Headquarters for information of any kind, whether it concerns membership, legislation, or general questions on the construction or operation of amateur apparatus. If you don't find the information you want in *QST* or the *Handbook*, write to A.R.R.L. Headquarters, West Hartford, Connecticut, telling us your problem. All replies are made directly by letter; no charge is made for the service.

If you come to Hartford, drop out to Headquarters at 38 LaSalle Road, West Hartford. Visitors are always welcome.

Headquarters Stations

FROM 1927 to 1936 the League operated its headquarters station, W1MK, at Brainerd Field, Hartford's municipal airport on the Connecticut River. During the disastrous flood of 1936 this station was devastated. From the spring of 1936 until early summer of 1938 a temporary station was operated at the headquarters offices, at first under the old auxiliary call W1INF and later as W1AW. The call W1AW, held until his death by Hiram Percy Maxim, was issued to the League by a special order of the Federal Communications Commission for the official headquarters station call.

Beginning September, 1938, the Hiram Percy Maxim Memorial Station at Newington, Conn., has been in operation as the headquarters station. Operating on all amateur bands, with

The Radio Amateur's Handbook

separate transmitters rated at the maximum legal input of one kilowatt and elaborate antenna systems, this station is heard with good strength in every part of the world. The building in which it is housed was designed by order of the League's Board of Directors as a permanent memorial to the founder-president, Hiram Percy Maxim.

Joining the League

THE best way to get started in the amateur game is to join the League and start reading *QST*. Inquiries regarding membership should be addressed to the Secretary. There is a convenient application blank in the rear of this book. An interest in amateur radio is the only qualification necessary in becoming a member of the A.R.R.L. Ownership of a station and knowledge of the code are *not* prerequisites. They can come later. According to a constitutional requirement, however, only those members who possess an amateur station or operator license are entitled to vote in director elections.

Learn to let the League help you. It is organized solely for that purpose, and its entire headquarters' personnel is trained to render the best assistance it can to you in solving your amateur problems. If, as a beginner, you should find it difficult to understand some of the matter contained in succeeding chapters of this book, do not hesitate to write the Information Service stating your trouble. Perhaps, in such a case, it would be profitable for you to send for a copy of a booklet published by the League especially for the beginner and entitled "How to Become a Radio Amateur." This is written in simple, straightforward language, and describes from start to finish the building of a simple but effective amateur installation. The price is 25 cents, postpaid.

Every amateur should read the League's magazine *QST* each month. It is filled with

the latest amateur apparatus developments and "ham" news from your particular section of the country. A sample copy will be sent you for 25 cents if you are unable to obtain one at your local newsstand.

International Amateur Radio Union

THE I.A.R.U. is a federation of thirty-three national amateur radio societies in the principal nations of the world. Its purposes are the promotion and coördination of two-way communication between the amateurs of the various countries, the effecting of coöperative agreements between the various national societies on matters of common welfare, the advancement of the radio art, the encouragement of international fraternalism, and the promotion of allied activities. Perhaps its greatest service lies in representing the amateurs of the world at international telecommunications conferences and technical consulting committee (C.C.I.R.) meetings.

The headquarters society of the Union is the American Radio Relay League. All correspondence should be addressed to 38 LaSalle Road, West Hartford, Conn., U. S. A.

The I.A.R.U. issues WAC (Worked-All-Continents) certificates to amateurs who qualify for this award. The regulations, in brief, stipulate that the applicant must have worked other amateurs in each of the six recognized continental areas of the world, supplying QSL cards or other indisputable proof of two-way contact in connection with his application; and that he must be a member of the membership society of the Union for the country in which he resides. In countries where no membership society exists the certificate may be secured upon payment of a fee of 50¢ to cover mailing costs. Two kinds of certificates are issued, one for radiotelegraph work and one for radiotelephone. There is a special endorsement for 28-Mc. operation.

Getting Started

The Amateur Bands — Learning the Code — Obtaining Licenses

THIS chapter deals with the two major problems of every beginning amateur — learning the code and getting the necessary federal licenses.

Our Amateur Bands

To understand amateur radio, it is first necessary to know where amateurs operate. There are those who, because they have never heard anything else, think that "radio" means only "broadcasting." To such people a few nights listening in on the high frequencies (wavelengths below the broadcast band) will be a revelation. A horde of signals from dozens of different types of services tell their story to whoever will listen. Some stations send slowly and leisurely. Even the beginner can read them. Others race along furiously so that whole sentences become meaningless buzzes. There are both telegraph and telephone signals. Press messages, weather reports, high-frequency international broadcasting of voice and music, transmissions from government and experimental stations including picture transmissions and television, airplane dispatching, police calls, signals from private yachts and expeditions exploring the remote parts of the earth — these jam the short-wave spectrum from one end to the other.

Sandwiched in among all these services are the amateurs, the largest service of all. Thousands of their signals may be heard every night in the various bands set apart by international treaty for their use.

Many factors must be considered in picking the proper band for a certain job from among the several bands devoted to amateur operation. The distance to be covered enters into it, as well as the time of day when communication is desired. In addition to daily changes there are seasonal changes, and also a long-time change in atmospheric conditions which seems to coincide with the 11-year cycle of sun-spot or solar activity. The reliability of communication on a given frequency at a given time of day, the suitability of a given band for traffic or DX, the desires of the individual amateur in choosing his circle of friends with whom he expects to make contact on schedule, the amount of interference to be expected at certain hours, and the time of day available for operating —

all influence the choice of an operating frequency.

The 1750-kc. band, which carried all amateur activity before experimenters opened the way to each of the higher frequency bands in turn, always served amateurs well for general contact between points all over the country. There was a short period, during the height of development of the higher frequencies, when activity in this band dwindled, but it is again active.

The band is especially popular for radiotelephone work. Code practice transmissions are made in this band for beginning amateurs and many beginners may be heard in this region making their first two-way contact with each other. The band is one of our "widest" from the standpoint of the number of stations that may be comfortably accommodated. The band is open to amateur facsimile and picture transmission.

The 3500-kc. band has, in recent years, been regarded as best for all consistent domestic communication. It is good for coast-to-coast work at night all the year except for a few summer months. It has been recommended for all amateur message-handling over medium distances (1,000 miles, for example). Much of the friendly human contact between amateurs takes place in the 3500-kc. band. As the winter evening advances, the well-known "skip effect" (explained in detail in Chapter Four) of the higher frequencies has made itself known, the increased range of the "sky wave" brings in signals from the other coast and the increased range also brings in *more* stations, so that the band appears busier.

The 7000-kc. band has been the most popular band for general amateur work for years. It is useful mainly at night for contacts with the opposite coast, or with foreign countries. Power output does not limit the range of a station to the same extent as when working on the lower frequency bands discussed above. However, the band is more handicapped by congestion in the early evenings and more subject to the vagaries of skip-effect and uncertain transmission conditions than are the lower frequency bands, but not to the same extent as the 14-Mc. band. The 7000-kc. band is satisfactory for working distances of several

The Radio Amateur's Handbook

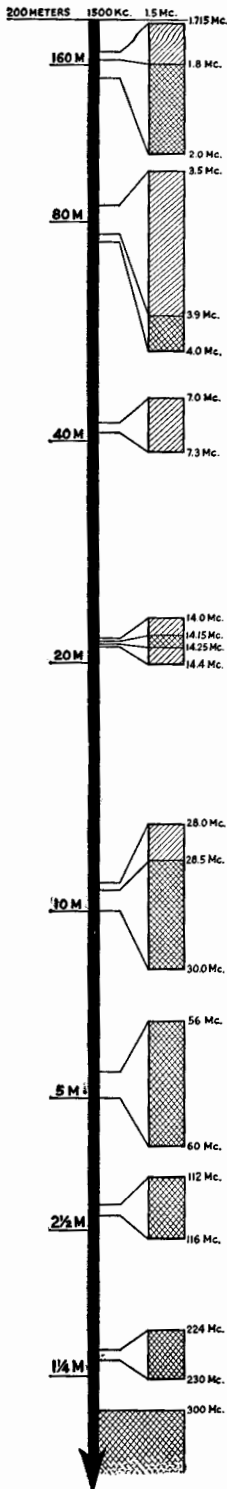

hundred miles in daylight. It is generally considered the most desirable night band for general DX work in spite of difficulties due to interference.

A The 14,000-kc. or 14-Mc. band is the best frequency to use to cover great distances in daylight. In fact it is the *only* band generally useful for daylight DX contacts (OSO's) over coast-to-coast and greater distances.

B Communication over long distances will usually remain good during the early evenings and surprising results can be obtained then, too. Using these higher frequencies there is often difficulty in talking with stations within three or four hundred miles, while greater distances than this (and very short distances within ten or twenty miles of a station) can be covered with ease. The reason that 14-Mc. signals are less useful for general amateur DX late evenings is because the "skip" increases during darkness until the "sky wave" covers greater than earthly distances.

C The band, while one of the very best for the amateur interested in working foreign stations, is sometimes subject to sudden fluctuations in transmitting conditions.

D The 28,000-kc. (28-Mc.) band combines both the long-distance characteristics of the 14-Mc. band and some of the local advantages of the 56-Mc. band, but its remarkable long-distance characteristics have been the cause of its tremendous growth in popularity. The band is by no means as reliable as those of lower frequency but the performance to be had on it has been becoming progressively better during the last few years. A well-defined seasonal effect produces much better conditions during the fall and spring than at other times of the year. Though the band was a barren waste a few years ago it is now, particularly during fall and spring, full of activity. It is the place where one can get by far the most miles per watt.

E The 56,000-kc. or 56-Mc. band is used largely for local and short-distance work over distances of ten to thirty miles. Because of the cheapness, compactness and ease of construction of the necessary apparatus, it has proved ideal for this purpose and many hundreds of stations operate "locally" there. Experiments with directive antennas by the technical staff of the A.R.R.L. beginning in 1934 disclosed that surprisingly consistent two-way contact could be maintained over distances of a hundred miles or more with suitable conditions and equipment, and such contacts are now common. Recent "sky-wave" DX work over several thousand miles on this band and the prospect that much more is to come make the band a prize one for the experimenter. Most of this work seems to occur during the month of May each year.

F The 112,000-kc. or 112-Mc. band is the newest addition to the amateur spectrum, and is gradually receiving occupancy. Its characteristics insofar as local work is concerned are similar to 56 Mc. The fact that elementary transceivers can be used, without the stability requirements of the lower frequencies, makes the band especially attractive for mobile work and general short-range activity.

G Above 116 Mc. but little progress has as yet been made by amateurs, although a few experimenters are persistently investigating this field. As yet the 224-Mc. band and the experimental region above 300 Mc. are not used for general communication, but it is logical to expect a gradual infiltration in the course of the next few years.

H Note: Since the drawing was made, the band "A" has been changed by F.C.C. to read 1750-2050 kc., with 1800-2050 kc. open to both 'phone and c.w.

communications, is sometimes subject to sudden fluctuations in transmitting conditions.

E The 56,000-kc. or 56-Mc. band is used largely for local and short-distance work over distances of ten to thirty miles. Because of the cheapness, compactness and ease of construction of the necessary apparatus, it has proved ideal for this purpose and many hundreds of stations operate "locally" there. Experiments with directive antennas by the technical staff of the A.R.R.L. beginning in 1934 disclosed that surprisingly consistent two-way contact could be maintained over distances of a hundred miles or more with suitable conditions and equipment, and such contacts are now common. Recent "sky-wave" DX work over several thousand miles on this band and the prospect that much more is to come make the band a prize one for the experimenter. Most of this work seems to occur during the month of May each year.

F The 112,000-kc. or 112-Mc. band is the newest addition to the amateur spectrum, and is gradually receiving occupancy. Its characteristics insofar as local work is concerned are similar to 56 Mc. The fact that elementary transceivers can be used, without the stability requirements of the lower frequencies, makes the band especially attractive for mobile work and general short-range activity.

G Above 116 Mc. but little progress has as yet been made by amateurs, although a few experimenters are persistently investigating this field. As yet the 224-Mc. band and the experimental region above 300 Mc. are not used for general communication, but it is logical to expect a gradual infiltration in the course of the next few years.

H Note: Since the drawing was made, the band "A" has been changed by F.C.C. to read 1750-2050 kc., with 1800-2050 kc. open to both 'phone and c.w.

Memorizing the Code

There is nothing particularly difficult incident to taking your place in the ranks of licensed amateurs.

The first job you should tackle is the business of *memorizing* the code. This can be done while

Getting Started

A	● —	1	● — — — —
B	— ● ● ●	2	● ● — — —
C	— ● — ●	3	● ● ● — —
D	— ● ●	4	● ● ● ● —
E	●	5	● ● ● ● ●
F	● — ● ●	6	— ● ● ● ●
G	— — ● ●	7	— — ● ● ●
H	● ● ● ●	8	— — — ● ●
I	● ●	9	— — — — ●
J	● — — — —	0	— — — — —
K	— ● ● —	[.]	● — ● ● ● —
L	● ● ● ●	[,]	— — ● ● ● —
M	— —	[?]	● ● — — ● ●
N	— ●	[:]	— — — ● ● ●
O	— — — —	[;]	— ● — — ● ● ●
P	● — — — ●	[']	— ● ● ● ● —
Q	— — ● ● —	[!]	None at present
R	— ● ●	[']	● — — — — ●
S	● ● ●	[/]	— ● ● ● ●
T	—	[()]	— ● — — ● ● ●
U	● ● —	[" "]	● — ● ● ● ●
V	● ● ● —		
W	● — — —		
X	— ● ● — —		
Y	— ● — — —		
Z	— — — ● ●		
&	● ● ● ●		
Error	● ● ● ● ● ● ● ●		
OK (Received)	— — — — ● ● ●		
Double Dash	— — ● ● ● —		
Invitation to transmit	— — — —		
Wait	● ● ● ● ● ●		
End of message	● — — — ● ●		
End of transmission	● ● ● — — —		
Thank you	— — ● ● ● —		

Fig. 202 — The Continental Code.

you are building your receiver. Thus, by the time the receiver is finished, you will know the characters for the alphabet and will be ready to practice receiving in order to acquire speed. Speed practice, either by means of a buzzer, or by listening in on your receiver, can be indulged in in odd moments while the transmitter, in turn, is being constructed. The net result of such an organized program should be that by the time the transmitter is finished you will be able to receive the thirteen words a minute required by the government for your amateur operator license, and can immediately proceed to study for the "theoretical" part of your license examination without loss of time.

Memorizing the code is no task at all if you simply make up your mind to apply yourself to the job and get it over with as quickly as possible. The complete Continental alphabet, punctuation marks and numerals are shown in the table given here. The alphabet and all the

numerals should be learned, but only the first eight of the punctuation marks shown need be memorized by the beginner. Start by memorizing the alphabet, forgetting the numerals and punctuation marks for the present. Various good systems for learning the code have been devised. They are of undoubted value but the job is a very simple one and usually can be accomplished easily by taking the first five letters, memorizing them, then the next five, and so on. As you progress you should review all the letters learned up to that time, of course. When you have memorized the alphabet you can go to the numerals, which will come very quickly since you can see that they follow a definite system. The punctuation marks wind up the schedule — and be sure to learn at least the first eight — the more commonly-used ones.

One suggestion: Learn to think of the letters in terms of *sound* rather than their appearance as they are printed. Don't think of A as "dot-dash" but think of it as the sound "dit-dah." B, of course, is "dah-dit-dit-dit," C, "dah-dit-dah-dit" and so on.

Even better will be listening to the characters as they are sent on a buzzer or code practice oscillator, if someone can be found to send to you. Learning the code is like learning a new language, and the sooner you learn to understand the language without mental "translation" the easier it will be for you.

Don't think about speed yet. Your first job is simply to memorize all the characters and make sure you know them without hesitation. Good practice can be obtained, while building the receiver, if you try to spell out in code the names of the various parts you are working on at the time.

Acquiring Speed by Buzzer Practice

When the code is thoroughly memorized, you can start to develop speed in receiving code transmission. Perhaps the best way to do this is to have two people learn the code together and send to each other by means of a buzzer-and-key outfit. An advantage of this system is that it develops sending ability, too, for the person doing the receiving will be quick to criticize uneven or indistinct sending. If possible, it is a good idea to get the aid of an experienced operator for the first few sessions, so that you will know what well-sent characters sound like.

The diagram shows the connections for a buzzer-practice set. When buying the key it is a good idea to get one that will be suitable for use in the transmitter later; this will save you money.

Another good practice set for two people learning the code together is that using a tube oscillator.

The Radio Amateur's Handbook

The parts required are: an old audio transformer, a type '30 tube, a pair of 'phones, key, two No. 6 dry cells, tube-socket, a 20-ohm filament rheostat, and a 22½-volt B battery. These are hooked up to form an audio oscillator. If nothing is heard in the 'phones when the key is depressed, reverse the leads going to the two binding posts at either transformer winding. Reversing both sets of leads will have no effect.

Either the buzzer set or the audio oscillator described will give satisfactory results. The advantage of an audio oscillator over the buzzer set is that it gives a good signal in the 'phones without making any noise in the room, and also produces a tone more closely simulating actual radio signals.

After the practice set has been built, and another operator's help secured, practice sending turn and turn about to each other. Send single letters at first, the listener learning to recognize each character quickly, without hesitation. Following this, start slow sending of complete words and sentences, always trying to have the material sent at just a little faster rate than you can copy easily; this speeds up your mind. Write down each letter you recognize. Do *not* try to write down the dots and dashes; write down the letters. Don't stop to compare the sounds of different letters, or think too long about a letter or word that has been missed. Go right on to the next one or each "miss" will cause you to lose several characters you might otherwise have gotten. If you exercise a little patience you will soon be getting every character, and in a surprisingly short time will be receiving at a good rate of speed. When you think you can receive 13 words a minute (65 letters a minute) have the sender transmit code groups rather than straight English text. This will prevent you from recognizing a word "on the way" and filling it in before you've really listened to the letters themselves.

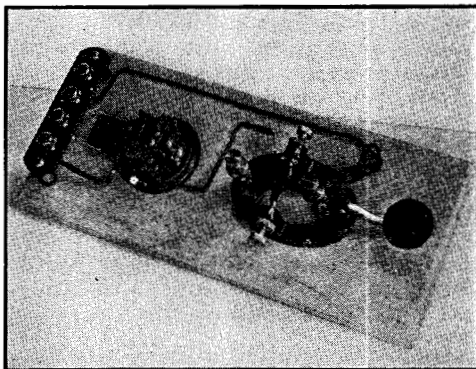

Fig. 203 — A Buzzer Code Practice Set.

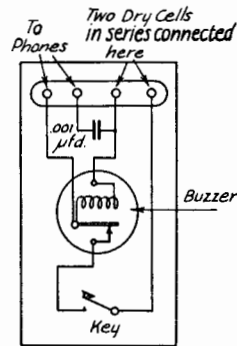

Fig. 204 — Circuit of the buzzer code practice set shown in Fig. 203. The 'phones are connected across the coils of the buzzer with a condenser in series. The size of this condenser determines the strength of the signal in the 'phones. Should the value shown give an excessively loud signal, it may be reduced to 500 or even 250 μfd .

After you have acquired a reasonable degree of proficiency concentrate on the less common characters, as well as the numerals and punctuation marks. These prove the downfall of many applicants taking the code examination under the handicap of nervous stress and excitement.

Learning by Listening

While it is very nice to be able to get the help of another person in sending to you while you are acquiring code-speed, it is not always possible to be so fortunate, and some other method of acquiring speed must be resorted to. Under such circumstances, the time-honored system is to "learn by listening" on your short-wave receiver. With even the simplest short-wave receivers a number of high-power stations can be heard in every part of the world. It is usually possible to pick a station going at about the desired speed for code practice. Listen to see if you cannot recognize some individual letters. Use paper and pencil and write down the letters as you hear them. Try to copy as many letters as you can.

Whenever you hear a letter that you know, write it down. Keep everlastingly at it. *Twenty minutes or half an hour is long enough for one session.* This practice may be repeated several times a day. Don't become discouraged. Soon you will copy without missing so many letters. Then you will begin to get calls, which are repeated several times, and whole words like "and" and "the." After words will come sentences. You now know the code and your speed will improve slowly with practice.

In "learning by listening" try to pick stations sending slightly faster than your limit. In writing, try to make the separation between words definite. Try to "read" the whole of short words before starting to write them down.

Getting Started

Do the writing while listening to the first part of the next word. Practice and patience will soon make it easy to listen and write at the same time. Good operators usually copy several words "behind" the incoming signals.

A word of caution: the U. S. radio communication laws prescribe heavy penalties for divulging the contents of any radiogram to other than the addressee. You may copy anything you hear in the amateur bands for practice but you must preserve its secrecy.

Volunteer Code Practice Stations

Each fall and winter season the A.R.R.L. solicits volunteers, amateurs using code only, or often a combination of voice and code transmission, who will send transmissions especially calculated to assist beginners. These transmissions go on the air at specified hours on certain days of the week and may be picked up within a radius of several hundred miles under favorable conditions. Words and sentences are sent at different speeds and repeated by voice, or checked by mail for correctness if you write the stations making the transmissions and enclose a stamped, addressed envelope for reply.

The schedules of the score or more volunteer code-practice stations are listed regularly in *QST* during the fall and winter. Information at other times may be secured by writing League headquarters. Some of the stations have been highly successful in reaching both coasts with code-practice transmissions from the central part of the country.

Interpreting What You Hear

As soon as you finish your receiver and hook it up you will begin to pick up different high-frequency stations, some of them perhaps in the bands of frequency assigned to amateurs, others perhaps commercial stations belonging to different services. The loudest signals will not necessarily be those from near-by stations. Depending on transmitting conditions which vary with the frequency, the distance and the time of day, remote stations may or may not be louder than relatively near-by stations.

The first letters you identify probably will be the call signals identifying the stations called and the calling stations, if the stations are in the amateur bands. Station calls are assigned by the government, prefixed by a letter (W in the United States, VE in Canada, G in England, etc.) indicating the country. In this country amateur calls will be made up of such combinations as W8CMP, W1KH, W1AW, etc., the number indicating the amateur call area and giving a general idea of the part of the country in which the station heard is located. The reader is referred to the chapter on "Operating a Station" for complete information on the procedure amateurs use in call-

ing, handling messages, and the like. Many abbreviations are used which will be made clear by reference to the tables of Q Code, miscellaneous abbreviations, and "ham" abbreviations included in the Appendix. The table of international prefixes, also in the back of the book, will help to identify the country where amateur and commercial stations are located.

Using a Key

The correct way to grasp the key is important. The knob of the key should be about eighteen inches from the edge of the operating table and about on a line with the operator's right shoulder, allowing room for the elbow to rest on the table. A table about thirty inches in height is best. The spring tension of the key varies with different operators. A fairly heavy spring at the start is desirable. The back adjustment of the key should be changed until there is a vertical movement of about one-sixteenth inch at the knob. After an operator has mastered the use of the hand key the tension should be changed and can be reduced to the minimum spring tension that will cause the key to open immediately when the pressure is released. More spring tension than necessary causes the expenditure of unnecessary energy. The contacts should be spaced by the rear screw on the key only and not by allowing play in the side screws, which are provided merely for aligning the contact points. These side screws should be screwed up to a setting which prevents appreciable side play but not adjusted so tightly that binding is caused. The gap between the contacts should always be at least a thirty-second of an inch, since a too-finely spaced contact will cultivate a nervous style of sending which is highly undesirable. On the other hand too-wide spacing (much over one-sixteenth inch) may result in unduly heavy or "muddy" sending.

Do not hold the key tightly. Let the hand rest lightly on the key. The thumb should be against the left side of the key. The first and second fingers should be bent a little. They should hold the middle and right sides of the knob, respectively. The fingers are partly on top and partly over the side of the knob. The other two fingers should be free of the key. The photograph shows the correct way to hold a key.

A wrist motion should be used in sending. The whole arm should not be used. One should not send "nervously" but with a steady flexing of the wrist. The grasp on the key should be firm, not tight, or jerky sending will result. None of the muscles should be tense but they should all be under control. The arm should rest lightly on the operating table with the wrist held above the table. An up-and-down motion without any sideways action is best. The fingers should never leave the key knob.

The Radio Amateur's Handbook

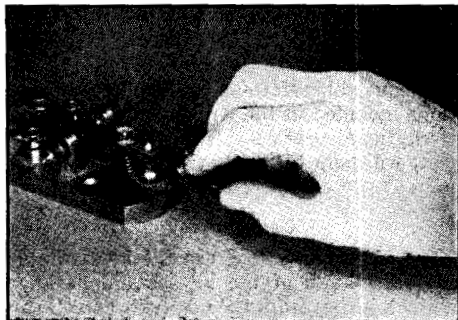

Fig. 205 — Illustrating the correct position of the hand and fingers for the operation of a telegraph key.

Sending

Good sending *seems* easier than receiving, but don't be deceived. A beginner should not send fast. Keep your transmitting speed down to the receiving speed, and bend your efforts to sending *well*.

When sending do not try to speed things up too soon. A slow, even rate of sending is the mark of a good operator. Speed will come with time alone. Leave special types of keys alone until you have mastered the knack of properly handling the standard-type telegraph key. Because radio transmissions are seldom free from interference, a "heavier" style of sending is best to develop for radio work. A rugged key of heavy construction will help in this.

Obtaining Government Licenses

When you are able to copy 13 words per minute, have studied basic transmitter theory and familiarized yourself with the radio law and amateur regulations, you are ready to give serious thought to securing the government combination amateur operator-station license which is issued you, after examination, through the Federal Communications Commission, at Washington, D. C.

Because a discussion of license application procedure, license renewal and modification, exemptions, and detailed information on the nature and scope of the license examination involve more detailed treatment than it is possible to give within the limitations of this chapter, it has been made the subject of a special booklet published by the League, and at this point the beginning amateur should possess himself of a copy and settle down to a study of its pages in order to familiarize himself with the intricacies of the law and prepare

himself for his test. The booklet, "*The Radio Amateur's License Manual*," may be obtained from A.R.R.L. headquarters for 25¢ postpaid. From the beginner's standpoint one of the most valuable features of this book is its list of nearly 200 representative examination questions with their correct answers.

A few general remarks:

While no government licenses are necessary to operate receivers in the United States, you positively must have the required amateur licenses before doing sending of any kind with a transmitter. This license requirement applies for any kind of transmitter on any wavelength. Attempts to engage in transmitting operation of any kind, without holding licenses, will inevitably lead to arrest, and fine or imprisonment.

Amateur licenses are free, but are issued only to citizens of the United States; this applies both to the station authorization and the operator's personal license, with the further provision in the station license that it will not be issued where the apparatus is to be located on premises controlled by an alien. But the requirement of citizenship is the only limitation, and amateur licenses are issued without regard to age or physical condition to anyone who successfully completes the required examination. There are licensed amateurs as young as twelve and as old as eighty. Many permanently bed-ridden persons find their amateur radio a priceless boon and have successfully qualified for their "tickets"; even blindness is no bar — several stations heard regularly on the air are operated by people so afflicted.

Persons who would like to operate at amateur stations, but do not have their own station as yet, may obtain an amateur operator license without being obliged to take out a station license. But no one may take out the station license alone; all those wishing station licenses must also take out operator licenses.

Extracts from the basic Communications Act and the complete text of the amateur regulations current at the time this *Handbook* went to press will be found in the Appendix. Because the regulations are subject to occasional changes or additions, however, it is recommended that your study of them be from the *License Manual* already mentioned, since this latter publication is always revised, or a "change sheet" incorporated with it, whenever such alterations in our regulations take place.

PRACTICE CIPHER GROUPS

Cipher groups make better practice material than plain English because you can't foresee the next letter. The groups below, taken from the operator's manual of the Signal Corps, are representative both of the practice material used in service schools and of ciphered messages actually used in the services. Their breakdown into 5-letter units makes it easy for you to determine your speed, since speed is figured on the basis of 5 characters to a word.

When you can *send* from this list without fumbling for an unusual letter, you know the code. Such sending also glaringly dis-

plays any errors in spacing the letters into words. And, with someone to send to you, such material of course provides the best possible *copying* practice. Check back for your errors, concentrate on the letters that are proving difficult for you. If you find yourself memorizing some of the combinations or their order, use each group backwards or start from the bottom of the page. There are plenty of practice possibilities in the following list, even for the experienced amateur who is seeking higher speed on the typewriter. The use of a typewriter for copying should be encouraged.

OKICQ	CEMID	9 7 2 0 1	ALCRJ	MAIDP	JRNOL
2 4 6 8 0	JXEFY	EFXNK	DLZIK	7 6 3 2 1	EWSKM
CKTOG	EFMEY	LCKQH	PHVTX	7 0 3 6 5	HZGNA
AXBTR	4 9 2 8 5	OCYAA	HIMAD	OHWIM	SFMCG
0 3 7 5 9	JNABD	ZLJBI	CPNZI	VTNEE	FMEMI
CWXCK	JBCYD	8 4 7 0 7	JBOAH	HELKF	ZDLYS
DKAKX	PGZUN	KDKNG	GYEVS	4 7 3 8 2	KTLES
WQYFZ	CTILL	FHFUX	ARJZU	MRFXE	WBPCM
OMIWG	THQVI	NTVMG	DXAQN	4 0 3 6 7	SPEJN
HSPCQ	HMOUS	WOHZR	1 1 9 0 2	OBRDK	VIODO
XGLDT	TVCPT	IPAZQ	0 6 1 4 3	PVFKQ	CUBEZ
8 0 7 0 1	CPTKO	FNZQJ	CPTKO	RBEFP	AXTRX
RKMOZ	2 0 1 8 4	PGMAE	IRAGO	KDIEY	KCNYQ
EKJCD	VNFBH	1 0 2 7 3	PZOKA	MDIDH	EIURY
DJHNG	DIEUY	DXNZE	OQUIW	0 9 1 6 5	MCNBS
HAHGJ	JCUWH	9 8 2 3 4	MCNUY	QZASU	IHDJI
LDOSJ	8 3 7 4 6	JEHDY	BCNBX	CVFZA	SCQZW
1 2 3 1 0	LKDOP	MCNCB	ZAOIZ	ZLKAM	ZJHFG
BAYQT	WEQFQ	PAOKU	3 0 2 1 0	JDMNF	DKUER
QNBVA	1 7 8 6 3	MDHNV	TQRYW	EIOUW	MXNBG
2 5 8 9 4	MVHVD	UEYTA	ZMNZB	ZXVGX	OIEUZ
JXHGG	APLKM	QYEUR	NDBGY	UYRHI	LKCCN
9 8 0 1 5	NDHBH	QWZXN	KDIOE	DYAFH	LPWCA
MBUDF	JTIOE	MNOPA	CVQAR	1 2 7 5 4	OEVAN
AEIOU	MNLFG	KQZAX	NASTF	PONDL	FAWZX
1 3 5 7 9	YOUMK	LARDO	CFGIL	NPQRT	QWERT
CJRNO	VOIUM	MQECV	CADXA	SNKAD	CUTYR
YOUMK	1 2 7 0 9	BEXZB	TTLOR	KOBDZ	RGLBH

Electrical and Radio Fundamentals

Current Flow — Conductors and Insulators — Condensers — Coils — Tuned Circuits — Vacuum Tube Fundamentals

ONE will recall from high-school chemistry that all matter — solids, liquids and gases — is made up of fundamental units called *molecules*, the smallest subdivision of matter. These molecules in turn are found to consist of *atoms* of the component elements. Molecules and atoms are infinitesimally small, and can't be seen even with the most powerful microscopes. The thing to remember is that all matter is made up of molecules which are in turn combinations of atoms of the component elements.

Electrons

All atoms are made up of particles, or charges, of electricity — nothing more — and atoms differ from each other only in the number and arrangement of these charges. These charges are called *electrons*. The atom has a nucleus containing both positive and negative electrons, with the positive predominating so that the nature of the nucleus is positive. The charges in the nucleus are closely bound together. Exterior to the nucleus are negative electrons, some of which are not so closely bound and can be made to leave the vicinity of the nucleus without too much urging. These electrons whirl around the nucleus like the planets around the sun, and their orbits are not random paths but geometrically-regular ones determined by the charges on the nucleus and the number of electrons. Ordinarily the atom is electrically neutral, the outer negative electrons balancing the positive nucleus, but when something disturbs this balance electrical activity becomes evident, and it is the study of what happens in this unbalanced condition that makes up electrical theory.

● ELECTRONS AT REST

It was mentioned above that in some materials it is relatively easy to move the electrons



Fig. 301 — Lightning is caused by the discharge of electricity that builds up on a cloud reaching a potential high enough to break down the air between the cloud and ground or another cloud. The charge is believed to be caused by friction of air masses or dust particles.

away from the nucleus. There are also many materials in which this is difficult to do. A material in which it is hard to move or displace the electrons by electrical means is said to have a high *resistance*, and further along you will see why this is also an appropriate term from other standpoints.

Static Charges

Many materials that have a high resistance can be made to acquire a charge (surplus or deficiency of electrons) by mechanical means. You have often heard the "electricity" crackling when you ran your hard-rubber comb through your hair on a dry winter day, or have noticed the tiny spark that jumps from your finger tip to a metal object after you have walked across a rug in a dry room. This was caused simply by the friction of the comb passing through your hair and of your shoes passing over the carpet. The spark, in either case, was caused by the attempt of the charge that had built up to equalize itself. In other words, when you ran the comb through your hair, there was a surplus of electrons left on the comb, forming a charge, and the next time you brought the comb near your hair the charge was in such a hurry to equalize itself that it jumped a short distance through the air. The higher the charge, the greater the distance it can jump. Lightning is nothing more than the same thing on a gigantic scale; clouds pick up a tremendous charge (meteorologists don't agree as to *why*, but friction of air masses or dust particles is believed to be a contributing factor) and when the charge becomes great enough it breaks over in a blinding flash to ground or to another cloud with the *opposite* charge. Objects can have either a surplus or a deficiency of electrons — it is called a *negative* charge if there is a surplus of electrons; a *positive* charge if there is a lack of them. As with all things in nature, there must always be a balance, and for every negative charge there will be found a similar positive charge, since each electron that leaves an atom to form a negative charge leaves the rest of the atom with a positive charge.

You will have the essence if you remember that these charges or potentials are nothing

Electrical and Radio Fundamentals

more than a lack or surplus of electrons.

If two objects are charged differently, a *potential difference* is said to exist between them, and this difference is measured by an electrical unit called the *volt*. The greater the potential difference, the higher (numerically) the voltage. The difference in electrons between the two objects which causes this potential difference or voltage exerts an electrical pressure or *force* which is trying to equalize and thus nullify the charges, and for this reason it is often called *electromotive force* or, simply, *e.m.f.* However, one usually thinks of it as "voltage," remembering that voltage represents the electrical potential difference set up by a surplus or lack of electrons.

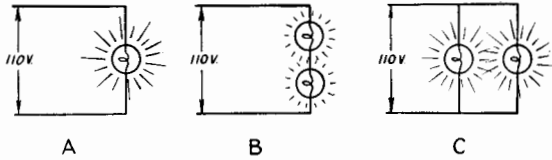

Fig. 303 — A simple example of Ohm's Law. At A, a single lamp across the 110-volt line burns with normal brilliancy, indicating normal current through the lamp.

At B, the two lamps in *series* give an effective resistance of twice that of a single lamp, and the current through them is therefore only half normal current. This is indicated by half brilliancy of the lamps.

At C, the lamps are connected in *parallel*, and since the lamps have 110 volts across them they burn with normal brilliancy. But twice as much light is given off, so the system must be drawing twice as much current and the effect of the two lamps in parallel is to place a load across the line of half the resistance of one lamp.

Condensers

Now is a good time to become acquainted with a fundamental electrical device used quite often in electrical and mechanical work, the *condenser*. So far, only static charges on combs and clouds have been mentioned. However, if two metal plates are separated a short distance by a high-resistance material, such as glass, mica, oil or air, or any one of a number of other materials, it will be found that the two plates can be given a charge by connecting them to a source of potential difference such as a battery or other power supply. The potential difference, or voltage, of the charge will be equal to that of the source. The *quantity* of the

charge will depend upon the voltage of the charging source and the *capacity* of the condenser. The value of capacity of a condenser is a constant depending upon the physical dimensions, increasing with the area of the plates and the thinness and *dielectric constant* of the insulating material in between.

Capacity is measured in *farads*, a unit much too large for practical purposes, and in radio work the terms *microfarad* (abbreviated $\mu\text{fd.}$) and *micro-microfarad* ($\mu\mu\text{fd.}$) are used. The microfarad is one-millionth of a farad, and the micro-microfarad is one-millionth of that.

One can easily demonstrate the difference in the quantity-holding ability of condensers by taking two of different capacity out of the junk box, touching them one at a time across a 45-volt B battery to charge them, and then discharging them with a screw driver across the terminals. The one with the larger capacity will give a fatter spark when it is discharged. Since they were both charged to exactly the same potential — the voltage of the battery — the difference in the discharges was due to the difference in the amount of stored charge.

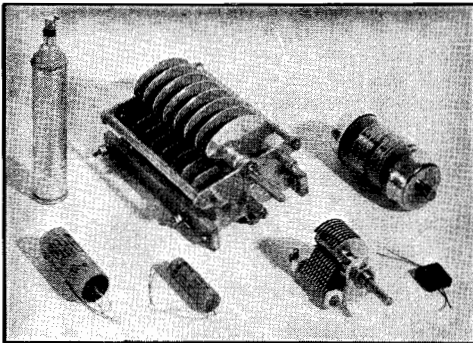

Fig. 302 — Various forms of condensers. The *electrolytic* condenser at the left front is a low-voltage one used as an audio by-pass across cathode resistors. The long, cylindrical can directly in back houses a higher-voltage electrolytic condenser used in receiver and low-voltage transmitter power-supply filters. The small paper (front row, second from left) and the small mica (front row, extreme right) fixed condensers are used in receiver and low-voltage transmitter applications. The small *variable* condenser in the front row is used in receivers and low-voltage transmitters; the variable condenser with the heavy plates and greater spacing is used in high-power transmitters. The small, compact vacuum condenser is a new type of fixed condenser for transmitting having an even greater voltage rating than the large variable condenser and losses low enough so that it may be used in a transmitter tank circuit.

Electrostatic Field

The electrical energy in a charged condenser is considered to be stored in much the same way that mechanical energy is stored in a stressed spring or rubber band. Whereas the mechanical energy in the spring can be stored because of the elasticity of the material, the electrical energy is stored in a condenser because of the *electrostatic field* that exists wherever a difference of potential occurs. The conception of a field, or lines of force, is adopted as the only way to explain the "action at a distance" of an electrical charge.

● ELECTRONS IN MOTION

It was mentioned above that a material in which it is difficult to move the electrons is said

The Radio Amateur's Handbook

to have high resistance. Conversely, a material in which it is easy to move the electrons is said to have low resistance or, more simply, it is called a good *conductor*. Most of the metals fall into this class, with silver and copper being among the best, followed by aluminum, brass, zinc, platinum and iron, in the order named. Conductors will, of course, conduct electricity regardless of their shape, but in most electrical work the most efficient form of conductor is a round wire, and henceforth when the word "conductor" is used, it should be visualized as a wire.

Current Flow

If a difference of potential exists across the ends of a conductor (by connecting the wire to a battery or generator or other source of voltage) there will be a continuous drift of electrons passing from atom to atom, and an electrical *current* is said to be flowing. The electrons do not streak from one end of the conductor to the other — their actual movement is quite minute — but it is more like a "bucket brigade" where, instead of firemen handing buckets down the line, atoms pass a potential difference down the line of the conductor until it is neutralized. The current itself may be traveling quite fast, close to the speed of light, but the actual electrons themselves move only a short distance.

The current is measured in *amperes*, and if you wish to visualize that in terms of electrons, try to remember that a current of one ampere represents nearly 10^{19} (ten million, million, million) electrons flowing past a point in one second; or that a micro-ampere (millionth of an ampere) is nearly 10 million electrons per micro-second (millionth of a second).

Ohm's Law

The current in a conductor is determined by two things, the voltage across the conductor

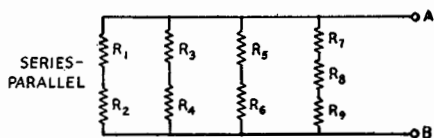
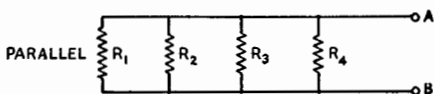
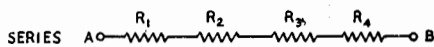

Fig. 304 — Diagrams of series, parallel and series-parallel resistance connections.

and the resistance of the conductor. The unit of resistance is the *ohm*, and, by definition, an e.m.f. of one volt will cause a current of one ampere to flow through a resistance of one ohm. Since the three quantities are interdependent, if we know the values of any two we can easily determine the third by the simple relation known as Ohm's Law. When I is the current in amperes, E is the electromotive force in volts and R is the circuit resistance in ohms, the formulas of Ohm's Law are:

$$R = \frac{E}{I} \quad I = \frac{E}{R} \quad E = IR$$

The *resistance* of the circuit can therefore be found by *dividing the voltage by the current*: the *current* can be found by *dividing the voltage by the resistance*: the *electromotive force* or *e.m.f.* is equal to the *product of the resistance and the current*.

The resistance of any metallic conductor depends upon the material and its temperature, its cross-sectional area and the length of the conductor. When resistance is deliberately added to a circuit, as is often done to adjust voltages or limit current flow, the resistance is usually lumped in a single unit and the unit is called a *resistor*.

Resistances in Series and Parallel

Resistors, like battery cells, may be connected in series, in parallel or in series-parallel. When two or more resistors are connected in series, the total resistance of the group is higher than that of any of the units. Should two or more resistors be connected in parallel, the total resistance is decreased. Fig. 304 and the following formulas show how the value of a bank of resistors in series, parallel or series-parallel may be computed, the total being between A and B in each case.

Resistances in series:

$$\text{Total resistance in ohms} = R_1 + R_2 + R_3 + R_4$$

Resistances in parallel:

$$\text{Total resistance in ohms} = \frac{1}{\frac{1}{R_1} + \frac{1}{R_2} + \frac{1}{R_3} + \frac{1}{R_4}}$$

Or, in the case of only 2 resistances in parallel,

$$\text{Total resistance in ohms} = \frac{R_1 R_2}{R_1 + R_2}$$

Resistances in series-parallel:

$$\text{Total resistance in ohms} = \frac{1}{\frac{1}{R_1 + R_2} + \frac{1}{R_3 + R_4} + \frac{1}{R_5 + R_6} + \frac{1}{R_7 + R_8 + R_9}}$$

Ionization

All conduction does not necessarily take place in solid conductors. If a glass tube is

Electrical and Radio Fundamentals

fitted with metal plates at each end, and filled with a gas or even ordinary air (a mixture of gases) at reduced pressure, an electric current may be passed *through the gas* if a high-enough voltage is applied across the metal terminals. The commonly-used neon advertising signs utilize this principle, since the current flow also generates light, the color depending upon the gas being used. When the voltage is applied across the tube, the positively charged plate attracts a few electrons, which are given considerable velocity due to the acceleration of the electric charge and the fact that the reduced pressure in the tube (less gas) permits the electrons to travel farther before colliding with a gas atom. When they do collide with the atoms, they knock off outer electrons of the gas atom and these electrons also join the procession towards the positive plate, and of course knock off more electrons from other atoms. The atoms that have had an electron or two knocked off are no longer true atoms but *ions*, and since they have a positive charge (due to the electron deficiency) they are called "positive ions." These positive ions, being heavier than the electrons, travel more slowly towards the negative plate, where they acquire electrons and become neutral atoms again. The net result is a flow of electrons, and hence of current, from negative plate to positive plate. The light given off, it may be mentioned, is considered incidental to the recombination of ions and free electrons at the negative plate. This kind of conduction, made possible by ionization by collision, is utilized in the operation of certain types of gaseous rectifiers, and in combination with another principle in mercury-vapor rectifiers.

Electrolytic Conduction

A very large number of chemical compounds have the peculiar characteristic that when they are put into solution the component parts become ionized. For example, common table salt or sodium chloride, each molecule of which is made up of one atom of sodium and one of chlorine, will, when put into water, break down into a sodium ion (positive, with one electron deficient) and a chlorine ion (negative, with one excess electron). This can only occur as long as the salt is in solution — take away the water and the ions are recombined into the neutral sodium chloride. This spontaneous *disassociation* in solution is of course another form of ionization, and if two wires with a difference of potential across them are placed in the solution, the negative wire will attract the positive sodium ions and the positive wire will attract the negative chlorine ions, and a current will flow through the solution. When the ions reach the wires the electron surplus or deficiency will be remedied, and a

neutral atom will be formed. The energy supplied by the source of potential difference is used to move the ions through the liquid and to supply or remove electrons. This type of current flow is due to *electrolytic conduction*, and the principle was utilized in the now almost-obsolete "electrolytic rectifier." It also forms a basis for the construction of the "electrolytic condenser."

Batteries

All batteries depend upon chemical action for the generation of a potential difference across their terminals. The common *dry cell* (which won't work *completely* dry) depends upon zinc ions (the metal case of a dry cell is the zinc plate) with a positive charge going into solution and leaving the zinc plate strongly negative. The electrical energy is derived from the chemical energy, and in time the zinc will be used up or worn away. However, in lead *storage batteries*, such as are used in automobiles for starting, the electrical energy is stored by chemical means and entails no destruction of the battery materials. The water that must be replaced from time to time is lost by evaporation.

It might be pointed out here that the term "battery" is used correctly only when speaking of more than one cell — a single cell is not a battery, but two or more connected together become a battery.

Thermionic Conduction

There is still another method of electric current conduction, one of the most important in radio because it is the foundation for the whole wonderful family of *vacuum tubes* used in both reception and transmission. If a suitable metallic conductor, such as tungsten or oxide-coated or thoriated tungsten, is heated to a

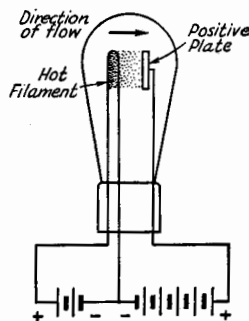

Fig. 305 — Illustrating conduction by thermionic emission of electrons in a vacuum tube. One battery is used *only* to heat the filament to a temperature where it will emit electrons. The other battery places a positive potential on the plate, with respect to the filament, and the electrons are attracted to the plate. The flow of electrons completes the electrical path, and current flows in the plate circuit.

The Radio Amateur's Handbook

high temperature in a vacuum (by passing current through it until it heats to the proper temperature) electrons will be emitted from the surface. The electrons are freed from this *filament* or *cathode* because it has been heated to a temperature that activates them sufficiently to allow them to break away from the surface. The process is called *thermionic electron emission*, or simply *emission*. Once free, these electrons form a cloud of negative electrons immediately surrounding the cathode which will repel further electrons that try to break through this *space charge*. A few will be given sufficient velocity to travel some distance from the cathode, but the majority will stay in the vicinity of the cathode. However, if a plate is placed in the vacuum tube, and given a positive charge by connecting a battery between plate and cathode, this plate or *anode* will attract a number of the electrons that surround the cathode. The passage of these electrons from cathode to anode constitutes an electric current. Some of the electrons that reach the anode may have sufficient velocity to dislodge an electron or two from the plate, and these electrons can be attracted to other positively-charged plates in the vicinity. If there are no other positive plates nearby, the electrons are attracted back to the plate from which they came. The process of dislodging electrons by other fast-moving electrons is called *secondary emission*. The important thing to remember is that all thermionic vacuum tubes depend for their operation on the emission of electrons from a hot cathode, and that the current flowing through a vacuum tube is simply the flow of these electrons being attracted to a positively-charged plate or anode.

Insulators

Materials with a very high resistance, like hard rubber, steatite, bakelite, isolantite, mica, mycalex, quartz, sulphur and vacuum are called *insulators*. If an insulator is used to separate the plates of a condenser, it is called a *dielectric*. Poor conductors are good insulators, and *vice versa*. Insulators are used where it is desired to avoid current flow through a physical connection.

Heating Effect and Power

When current passes through a conductor, there is some amount of molecular friction, and this friction generates heat. This heat is dependent only upon the current in the conductor, the resistance of the conductor and the time during which the current flows. The power used in heating or the heat dissipated in the circuit (which may be considered sometimes as an undesired power loss) can be determined by substitution in the following equations:

$$P = EI,$$
$$\text{or } P = I^2R,$$
$$\text{or } P = \frac{E^2}{R}$$

P being the power in watts, E the e.m.f. in volts, and I the current in amperes.

It will be noted that if the current in a resistor and the resistance value are known, we can readily find the power. Or if the voltage across a resistance and the current through it are known or measured by a suitable voltmeter and ammeter, the product of volts and amperes will give the power. Knowing the approximate value of a resistor (ohms) and the applied voltage across it, the power dissipated is given by the last formula.

Likewise, when the power and resistance in a circuit are known, the voltage and current can be calculated by the following equations derived from the power formulas given above:

$$E = \sqrt{PR}$$

$$I = \sqrt{\frac{P}{R}}$$

Magnetic Field

Any physicist will tell you that *moving electrons generate a magnetic field*. This magnetic field is exactly the same as the strange force that exists in the vicinity of any magnet and is capable of attracting other magnetic materials. Since a current in a wire is electrons in motion, it is not strange that a magnetic field is found in the vicinity of a conductor with current flowing through it.

There is a converse to this. When a conductor is moved through a magnetic field (or the field is moved past the conductor) electrons in the conductor are forced to move, producing a current. *An electric current generates a magnetic field about it and, conversely, an electric current is generated by a magnetic field moving (or changing) past the conductor.*

Magnetic fields are in the form of lines surrounding the wire; they are termed *lines of*

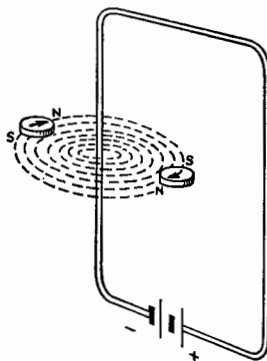

Fig. 306—Whenever current passes through a wire, a magnetic field exists around the wire. Its direction can be traced by means of a small compass.

Electrical and Radio Fundamentals

magnetic force. These lines of force, in the form of concentric circles around the conductor, lie in planes at right angles to the axis of the conductor.

The magnetic field constituted by these lines of force exists only when current is flowing through the wire. When the current is started through the wire, we may visualize the magnetic field as coming into being and sweeping outward from the axis of the wire. And on the cessation of the current flow, the field collapses toward the wire again and disappears. *Thus energy is alternately stored in the field and returned to the wire.* When a conductor is wound into the form of a coil of many turns, the magnetic field becomes stronger because

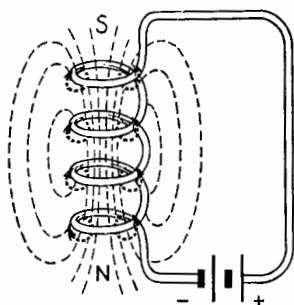

Fig. 307 — When the conducting wire is coiled, the individual magnetic fields of each turn are in such a direction as to produce a field similar to that of a bar magnet.

there are more lines of force, and the effect can be increased still further by placing an iron core within the coil. The force is expressed in terms of *magneto-motive force (m.m.f.)* which depends on the number of turns of wire, the size of the coil and the amount of current flowing through it. The same magnetizing effect can be secured with a great many turns and a weak current or with fewer turns and a greater current. If 10 amperes flow in one turn of wire, the magnetizing effect is 10 *ampere-turns*. Should one ampere flow in 10 turns of wire, the magnetizing effect is also 10 *ampere-turns*.

Inductance

When a source of voltage is connected across a coil, the current does not immediately reach the value predicted, by Ohm's Law, for the applied voltage and the resistance of the coil. The reason for this is that, as the current starts to flow through the coil, the magnetic field around the coil builds up. As this field builds up, it induces a voltage back in the coil, and the current caused by this induced voltage is always in the opposite direction to the current originally passed through the coil. Therefore, because of this property of *self-induction*,

the coil tends constantly to oppose any change in the current flowing through it, and it takes an appreciable amount of time for the current to reach its normal value through the coil. The effect can be visualized as electrical inertia. After the current has come to a steady value, the self-inductance has no effect, and the current is only limited by the resistance of the wire in the coil.

The inductance of a coil is measured in henrys or, when smaller units are more convenient, the millihenry (one-thousandth of a henry) or microhenry (one-millionth of a henry). The inductance of a coil depends on several factors (see Chapter Twenty), chief of which are the number of turns and the cross-sectional area of the coil. The inductance can be greatly increased by using iron instead of air for a core material.

Electric Circuits

You will often see mention of an electric "circuit." It is sufficient to remember that this is simply a complete path along which electrons can transmit their charge. More completely, there will normally be a source of energy — a battery, generator, or magnetic means for inducing current flow — and a *load* or portion of the circuit where the current is made to do useful work. There must be an unbroken path through which the electrons can transmit their charges, with the source of energy acting as an electron pump and sending them around the circuit. The circuit is said to be *open* when no charges can move, due to a break in the path. It is *closed* when no break exists — when switches are closed and all connections are properly made.

● ELECTRONS IN MOTION — ALTERNATING CURRENT

Thus far only direct current, i.e., current traveling in one direction, has been discussed. However, most electrical and radio work utilizes *alternating current*, or current that alternates its direction in periodic fashion.

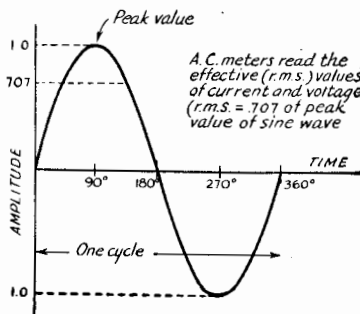

Fig. 308 — Representing sine-wave alternating current and voltage.

The Radio Amateur's Handbook

An electric current can be generated by a magnetic field moving or changing past a conductor. If the magnetic field moves in one direction, the electric current will flow in one direction; if the magnetic field moves in the opposite direction (decreasing is the same thing) in effect the current will move in the opposite direction. Mechanical methods are used to generate alternating current by this principle, using rotating machinery, and the machines are called *alternating-current generators* or *alternators*. Their design is such that the current in the wire (or voltage across the terminals) will go from zero to a peak value and back to zero, and up to a peak value in the opposite direction and back to zero, in what is called a *sine wave*. The length of time that it takes to go through this cycle is called the *period*; the number of times it goes through this cycle, per second, is called the *frequency*.

It may be easier to understand if the value of current (or voltage) is represented graphically as in Fig. 308. This is simply a chart showing that the current starts at zero value, builds up to a maximum in one direction, comes back down to zero, builds up to a maximum in the opposite direction and comes back to zero. This completes one cycle — 60 cycle (per second) current does this 60 times a second. The curve followed is described mathematically as a *sine curve*; it will be shown later how harmonics will change the general shape of the curve.

It is evident that both the voltage and current are swinging continuously between their positive maximum and negative maximum values, and it might be wondered how one can speak of so many amperes of alternating current when the value is changing continuously. The problem is simplified in practical work by considering that an *alternating current has an effective value of one ampere when it produces heat at the same average rate as one ampere of continuous direct current flowing through a given resistor*. This effective value is the square root of the mean value of the instantaneous current squared. For the sine-wave form,

$$E_{\text{eff}} = \sqrt{\frac{1}{2} E_{\text{max}}^2}$$

For this reason, the effective value of an alternating current, or voltage, is also known as the *root-mean-square* or *r.m.s.* value. Hence, the effective value is the square root of $\frac{1}{2}$ or 0.707 of the maximum value — practically considered 70% of the maximum value.

Another important value, involved where alternating current is rectified to direct current, is the *average*. This is equal to 0.636 of the maximum (or peak) value of either current or voltage. The three terms *maximum* (or *peak*), *effective* (or *r.m.s.*) and *average* are so important and are encountered so frequently in radio

work that they should be fixed firmly in mind right at the start.

They are related to each other as follows:

$$E_{\text{max}} = E_{\text{eff}} \times 1.414 = E_{\text{ave}} \times 1.57$$

$$E_{\text{eff}} = E_{\text{max}} \times .707 = E_{\text{ave}} \times 1.11$$

$$E_{\text{ave}} = E_{\text{max}} \times .636 = E_{\text{eff}} \times .9$$

The relationships for current are the same as those given above for voltage. The usual alternating current ammeter or voltmeter gives a direct reading of the effective or r.m.s. (root mean square) value of current or voltage. A direct current ammeter in the plate circuit of a vacuum tube approximates the average value of rectified plate current. Maximum values can be measured by a peak vacuum-tube voltmeter. Instruments for making such measurements are treated in Chapter Seventeen.

Transformers

If two coils of wire are wound on a laminated iron core, and one of the coils is connected to a source of alternating current, it will be found that there is an alternating voltage across the terminals of the other coil of wire, and an al-

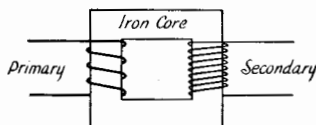

Fig. 309 — Schematic representation of a transformer. Alternating current flowing in the primary winding induces a current in the secondary winding. The ratio of the primary voltage to secondary voltage is very nearly equal to the ratio of primary turns to secondary turns.

ternating current will flow through a conductor connecting the two terminals. The explanation is simple: The alternating current in the first coil, or *primary*, causes a changing magnetic field in the iron core, and this changing magnetic field causes or induces an alternating current in the second coil, or *secondary*. The proportion of primary voltage to secondary voltage is very nearly the same as the ratio of primary turns; i.e., twice as many secondary turns as primary turns will give twice as much secondary voltage, etc. The current proportion goes the other way — it is inversely proportional to the turns ratio.

Reactance — Inductive and Capacitive

When alternating current passes through a coil, the effect described under "Inductance" (see page 27) is present not only when the circuit is first closed but at every reversal of the current, and the inductance of the coil limits the flow of current. The higher the frequency of the current the more the inductance will try to prevent its flow. Further, the higher the

Electrical and Radio Fundamentals

inductance the greater is the tendency to retard current of the same frequency. This characteristic of a coil, which depends both upon frequency and inductance, is termed the *reactance*, or *inductive reactance*.

We can readily understand how very different will be the performance of any condenser when direct or alternating voltages are applied to it. The direct voltages will cause a sudden charging current, but that is all. The alternating voltages will result in the condenser becoming charged first in one direction and then the other — this rapidly changing charging current actually being the equivalent of an alternating current through the condenser. Many of the condensers in radio circuits are used just because of this effect. They serve to allow an alternating current to flow through some portion of the circuit but at the same time prevent the flow of any direct current.

Of course, condensers do not permit alternating currents to flow through them with perfect ease. They impede an alternating current just as an inductance does. The term *capacitive reactance* is used to describe this effect in the case of condensers. Condensers have a reactance which is *inversely* proportional to the capacitance and to the frequency of the applied voltage.

It should not be thought that the reactance of coils becomes infinitely high as the frequency is increased to a high value and, likewise, that the reactance of condensers becomes infinitely low at high frequencies. All coils have some capacity between turns, and the reactance of this capacity can become low enough at some high frequencies to tend to cancel the high reactance of the coil. Likewise, the leads and plates of condensers will have considerable inductance at high frequencies, which will tend to offset the capacitive reactance of the condenser itself. For these reasons, chokes for high-frequency work must be designed to have low "distributed" capacity, and condensers must be wired with short, heavy leads to have low inductance. Formulas for calculating inductive and capacitive reactance can be found in Chapter Twenty.

Phase

It has been mentioned that in a circuit containing inductance, the rise of current is delayed by the effect of electrical inertia presented by the inductance. Both increases and decreases of current are similarly delayed. It is also true that a current must flow into a condenser before its elements can be charged and so provide a voltage difference between its terminals. Because of these facts, we say that a current "lags" behind the voltage in a circuit which has a preponderance of inductance and that the current "leads" the voltage

in a circuit where capacity predominates. Fig. 310 shows three possible conditions in an alternating current circuit. In the first, when the load is a pure resistance, both voltage and current rise to the maximum values simultaneously. In this case the voltage and current are said to be *in phase*. In the second instance, the existence of inductance in the circuit has caused the current to lag behind the voltage. In the diagram, the current is lagging one quarter cycle behind the voltage. The current is therefore said to be 90 degrees *out of phase* with the voltage (360 degrees being the complete cycle). In the third example, with a capacitive load, the voltage is lagging one quarter cycle behind the current. The *phase difference* is again 90 degrees. These, of course, are theoretical examples in which it is assumed that the inductance and the condenser have no resistance. Actually, the angle of lag or lead (*phase angle*) depends on the ratio of reactance to resistance in the circuit.

Another kind of phase relationship frequently encountered in radio work is that between two alternating currents of identical frequency flowing simultaneously in the same circuit. Even in a circuit of pure resistance the two currents will augment or nullify each other, depending on whether they are in phase or out of phase. When two such currents are of the same frequency and in phase they are said to be *synchronized*, the maximum amplitude of the combination then being the arithmetical sum of the two separate amplitudes. The maximum amplitude will be lessened as the phase differs, reducing to zero amplitude with two equal currents when the phase angle becomes 180 degrees. The latter condition is

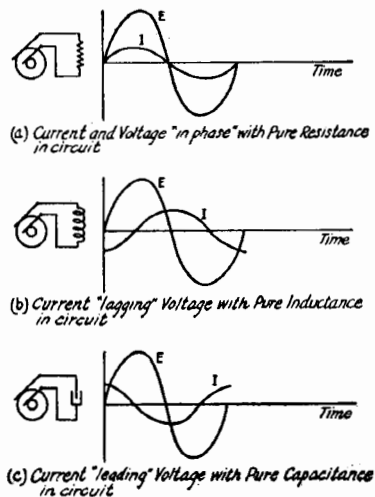

Fig. 310 — Voltage and current phase relations with resistance and reactance circuits.

The Radio Amateur's Handbook

known as *phase opposition* or, more commonly, *out of phase*.

Impedance (Z)

The combined effect of resistance and reactance is termed *impedance* in the case of both coils and condensers. The symbol for impedance is Z and, for a series circuit, it is computed from the formula:

$$Z = \sqrt{R^2 + X^2}$$

where R is the resistance and X is the reactance. The terms Z , R and X are all expressed in ohms. Ohm's Law for alternating current circuits then becomes

$$I = \frac{E}{Z}; \quad Z = \frac{E}{I}; \quad E = IZ$$

When a circuit contains resistance, capacitance and inductance, all three in series, the value of reactance will be the difference between that of the coil and that of the condenser. Since for a given coil and condenser the inductive reactance increases with frequency and capacitive reactance decreases with frequency, the inductive reactance (designated X_L) is conventionally considered positive and the capacitive reactance (X_C) negative. The net impedance $X = X_L - X_C$.

In finding the current flow through a condenser in an alternating current circuit we can usually assume that $I = \frac{E}{X_C}$. The use of the term Z (impedance) is, in such cases, made unnecessary because the resistance of the usual good condenser is not high enough to warrant consideration. When there is a resistance in series with the condenser, however, it can be taken into account in exactly the same manner as the resistance of the coil. The impedance of the condenser-resistance combination is then computed and used as the Z term in the Ohm's Law formulas.

Resonance

It has been shown that the inductive reactance of a coil and the capacitive reactance of a condenser are oppositely affected with frequency. Inductive reactance increases with frequency; capacitive reactance decreases as the frequency increases. In any combination of inductance and capacitance, therefore, there is one particular frequency for which the inductive and capacitive reactances are equal and, since these two reactances oppose each other, leaving only the resistance of the circuit to impede the flow of current. The frequency at which this occurs is known as the *resonant frequency* of the circuit and the circuit is said to

be *in resonance* at that frequency or *tuned* to that frequency.

The resonant frequency of a simple circuit containing inductance and capacity is given by

$$= \frac{1}{2\pi\sqrt{LC}} \times 10^6$$

where

f is the frequency in kilocycles per second

2π is 6.28

L is the inductance in microhenrys ($\mu\text{h.}$)

C is the capacitance in micro-microfarads ($\mu\mu\text{fd.}$)

The resonance equation in terms of wavelength is

$$\lambda = 1.885 \sqrt{L\mu\text{h.} C\mu\mu\text{fd.}}$$

where

λ is the wavelength in meters

$L\mu\text{h.}$ is the inductance in microhenrys

$C\mu\mu\text{fd.}$ is the capacitance in micro-microfarads

All practical tuned circuits can be treated as either one of two general types. One is the *series resonant* circuit in which the inductance,

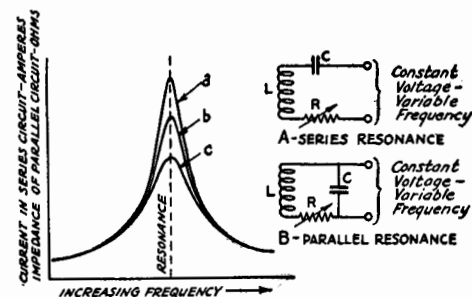

Fig. 311 — Characteristics of series-resonant and parallel-resonant circuits.

capacitance, resistance and source of voltage are in series with each other. With a constant-voltage alternating current applied as shown in A of Fig. 311 the current flowing through such a circuit will be maximum at resonant frequency. The magnitude of the current will be determined by the resistance in the circuit. The curves of Fig. 311 illustrate this, curve *a* being for minimum resistance and curves *b* and *c* being for greater resistances.

The second general case is the parallel resonant circuit illustrated in B of Fig. 311. This also contains inductance, capacitance and resistance in series, but the voltage is applied in parallel with the combination instead of in series with it as in A. Here we are not primarily interested in the current flowing through the circuit but in its characteristics as viewed from its terminals, especially in the *parallel impedance* it offers. The variation of parallel impedance of a parallel resonant circuit with

Electrical and Radio Fundamentals

frequency is illustrated by the same curves of Fig. 311 that show the variation in current with frequency for the series resonant circuit. The parallel impedance is maximum at resonance and increases with decreasing series resistance. Although both series and parallel resonant circuits are generally used in radio work, the parallel resonant circuit is most frequently found, as inspection of the diagrams of the equipment described in subsequent chapters will show.

High parallel impedance is generally desirable in the parallel resonant circuit and low series impedance is to be sought in series resonant circuits. Hence low series resistance is desirable in both cases.

Sharpness of Resonance (Q)

It is to be noted that the curves become "flatter" for frequencies near resonance frequency as the internal series resistance is increased, but are of the same shape for all resistances at frequencies further removed from resonance frequency. The relative sharpness of the resonance curve near resonance frequency is a measure of the *sharpness of tuning or selectivity* (ability to discriminate between voltages of different frequencies) in such circuits. This is an important consideration in tuned circuits used for radio work. Since the effective resistance is practically all in the coil, the condenser resistance being negligible (except at 28 Mc. and higher), the efficiency of the coil is normally the important thing determining the "goodness" of a tuned circuit. A useful measure of coil efficiency, and hence of tuned circuit selectivity, is the ratio of the coil's reactance to its effective series resistance. This ratio is designated by Q .

$$Q = \frac{2\pi fL}{R}$$

The value of Q is determined directly from the resonance curve of either a series-resonant or parallel-resonant circuit as shown in Fig.

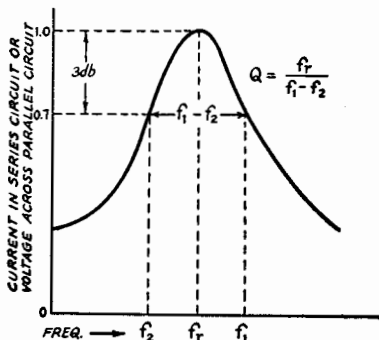

Fig. 312 — How the value of Q is determined from the resonance curve of a single circuit.

312. It is given by the ratio of the resonance frequency to the difference between the frequencies at which the series current (for the series-resonant circuit) or the parallel voltage (for the parallel-resonant circuit) becomes 70% of the maximum value. A value of Q that represents a well-designed coil at the lower frequencies will also represent an efficient coil on the higher frequencies. This value ranges from 100 to several hundred for good receiving coils and slightly higher for transmitter inductances. It must be remembered, however, that Q represents a ratio, so that the actual frequency width of the resonance curve would be proportionately greater for a high-frequency circuit than for a low-frequency circuit having the same value of Q .

Parallel-Resonant Circuit Impedance

The parallel-resonant circuit offers pure resistance (its resonant impedance) between its terminals at resonance frequency, and becomes reactive for frequencies higher and lower. The manner in which this reactance varies with frequency is shown by the indicated curve in Fig. 313. This figure also shows the *parallel resistance* component which combines with the

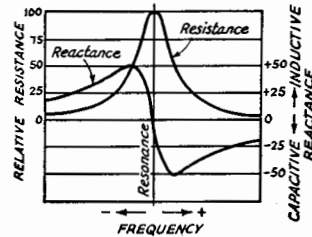

Fig. 313 — The impedance of a parallel-resonant circuit separated into its reactance and resistance components. The parallel resistance is equal to the parallel impedance at resonance.

reactance to make up the impedance. The reactive nature of parallel impedance at frequencies off resonance is important in a number of practical applications of parallel-tuned circuits, in both transmitters and receivers, and it will be helpful to keep this picture in mind.

The maximum value of parallel impedance which is obtained at resonance is proportional to the inductance and inversely proportional to the capacity and series resistance. (This resistance should not be confused with the resistance component of parallel impedance which has just been mentioned.)

$$\text{Resonant impedance} = \frac{L}{RC} = \frac{(2\pi f_r L)^2}{R}$$

$$\text{Since } \frac{2\pi f_r L}{R} = Q,$$

The Radio Amateur's Handbook

$$\text{Resonant impedance} = (2\pi fL)Q$$

In other words, the impedance is equal to the inductive reactance of the coil (at resonant frequency) times the Q of the circuit. Hence, the voltage developed across the parallel resonant circuit will be proportional to its Q . For this reason the Q of the circuit is not only a measure of the selectivity, but also of its gain or amplification, since the voltage developed across it is proportional to Z . Likewise, the Q of a circuit is related to the frequency stability of an oscillator in which it is used, the frequency stability being generally better as the circuit Q is higher.

The L - C ratio of a circuit is often mentioned, and it is simply the ratio of inductance to capacity in any particular circuit. A "high- L " (or "low- C ") circuit is one with more than normal inductance for the frequency or application.

Piezo Electricity

Properly-ground crystals of quartz, tourmaline and other materials show a mechanical strain when subjected to an electric charge and, conversely, will show a difference in potential between two faces when subjected to mechanical stress. This characteristic is called the *piezo-electric* effect and is utilized in several ways. Rochelle-salt crystals are utilized as microphone and headphone elements. A properly-ground quartz crystal is electrically equivalent to a series circuit of very high Q and as such is used to replace the frequency-determining coil and condenser in an oscillator circuit (see Chapter Five). It can also be used as a filter in the intermediate-frequency amplifier of a superheterodyne receiver to give greatly increased selectivity (see Chapter Four).

● CIRCUITS WITH DISTRIBUTED CONSTANTS — ANTENNAS AND R.F. CHOKES

In addition to resonant circuits containing lumped capacitance and inductance, there are important tuned circuits which utilize the distributed capacitance and inductance that are inevitable even in a circuit consisting of a single straight conductor. Transmitting and receiving antennas are such circuits and depend on their distributed capacitance and inductance for tuning. A peculiarity of such a circuit is that when it is excited at its resonant frequency the current or voltage, as measured throughout its length, will have different values at different points. For instance, if the wire happens to be one in "free space" with both ends open circuited, when it is excited at its resonant frequency the current will be maximum at the center and zero at the ends. On the other hand, the voltage will be maximum at the ends

and zero at the center. The explanation of this is that the traveling waves on the wire are reflected when they reach an end. Succeeding waves traveling toward the same end of the wire (the *incident* waves) meet the returning waves (*reflected* waves) and the consequence of this meeting is that currents add up at the center and voltages cancel at the center; while voltages add up at the ends and currents cancel at the ends. A continuous succession of such incident and reflected waves therefore gives the effect of a *standing wave* in the circuit.

A similar standing-wave or straight-line resonance effect is experienced even when the conductor is wound in a long spiral, or coil having diameter small in proportion to its length. A single-layer *radio-frequency choke* is such a coil. It offers particularly high impedance between its ends at its resonant frequency and also, as will be presently shown for antennas, at multiples of its fundamental resonant frequency. Either side of these resonance peaks it has fairly high impedance, if it is a good choke, and therefore is useful over a considerable band of frequencies. Practically the same results are obtained with chokes consisting of a number of layer-wound sections, with all the sections connected in series.

Frequency and Wavelength

Although it is possible to describe the constants of such line circuits in terms of inductance and capacitance, or in terms of inductance and capacitance per unit length, it is more convenient to give them simply in terms of fundamental resonant frequency or of length. In the case of a straight-wire circuit, such as an antenna, length is *inversely proportional to lowest resonant frequency*. Since the velocity of the waves in space is 300,000 kilometers (186,000 miles) per second, the *wavelength* of the waves is

$$\lambda = \frac{300,000}{f_{kc}}$$

where λ is the wavelength in meters and f_{kc} is the frequency in kilocycles. The *electrical* length of an antenna is specified in terms of the wavelength corresponding to the lowest frequency at which it will be resonant. This is known as its *fundamental* frequency or wavelength. As shown in the chapters on Antennas, the physical length is a few percent less than an actual half-wavelength for an ungrounded (Hertz) antenna and a quarter-wavelength for a grounded (Marconi) antenna. This shortening effect occurs because the velocity of the waves is less in a conductor than in space. It is common to describe antennas as *half-wave*, *quarter-wave*, etc., for a certain frequency ("half-wave 7000-kc. antenna," for instance).

Electrical and Radio Fundamentals

Wavelength is also used interchangeably with frequency in describing not only antennas but also for tuned circuits, complete transmitters, receivers, etc. Thus the terms "high-frequency receiver" and "short-wave receiver," or "75-meter fundamental antenna" and "4000-kilocycle fundamental antenna" are synonymous.

Harmonic Resonance

Although a coil-condenser combination having lumped constants (capacitance and inductance) resonates at only one frequency, circuits such as antennas containing distributed constants resonate readily at frequencies which are very nearly, although not exactly, integral multiples of the fundamental frequency (or wavelengths that are integral fractions of the fundamental wavelength). These frequencies are therefore in *harmonic* relationship to the fundamental frequency and, hence, are referred to as *harmonics*. In radio practice the fundamental itself is called the *first harmonic*, the frequency twice the fundamental is called the *second harmonic*, and so on.

Fig. 314 illustrates the distribution of the standing waves on a Hertz antenna for fundamental, second and third harmonic excitation.

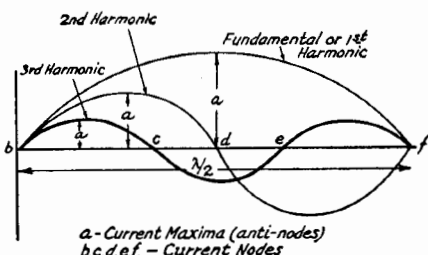

Fig. 314 — Standing-wave current distribution on an antenna operating as an oscillatory circuit at its fundamental, second harmonic and third harmonic frequencies.

There is one point of maximum current with fundamental operation, there are two when operation is at the second harmonic and three at the third harmonic; the number of current maxima corresponds to the order of the harmonic and the number of standing waves on the wire. As noted in the figure, the points of maximum current are called *anti-nodes* (also known as "loops") and the points of zero current are called *nodes*.

Radiation Resistance

It will be remembered that it was shown that current flow in a conductor was accompanied by a magnetic field about the conductor; and that with an alternating current the energy was alternately stored in the field in the form of lines of magnetic force and returned to the wire.

But when the frequency becomes higher than 15,000 cycles or so (radio frequency) all the energy stored in the field is not returned to the conductor but some escapes in the form of electro-magnetic waves. In other words, energy is radiated. Energy radiated by an antenna is equivalent to energy dissipated in a resistor. The value of this equivalent resistance is known as *radiation resistance*. The approximate value of power in an antenna can be computed by multiplying the assumed radiation resistance by the square of the maximum current in the antenna.

Resonant-Line Circuit

The effective resistance of a resonant straight wire — that is, of an antenna — is seen to be considerable. Because of the power radiated, or "coupled" to the surrounding medium, the resonance curve of such a straight-line circuit is quite broad. In other words, its *Q* is relatively low. However, by folding the line, as suggested by Fig. 315, the fields about the adjacent sections largely cancel each other and very small radiation results. The radiation resistance is greatly reduced and we have a line-type circuit which can be made to have a very sharp resonance curve or high *Q*.

A circuit of this type will have a standing wave on it, as shown by the dash-line of Fig. 315, with the instantaneous current flow in each wire opposite in direction to the flow in the other, as indicated by the arrows on the diagram. This opposite current flow accounts for the cancellation of radiation. Furthermore, the impedance across the open ends of the line will be very high, thousands of ohms, while the impedance across the line near the closed end will be very low, as low as 5 ohms or so at the least.

Matched-Impedance Lines

If a two-wire line were made infinitely long there would be no reflection from its far end when radio-frequency energy was supplied to the input end. Hence, there would be no standing waves on the line and it would be, in effect, non-resonant. The input impedance of such a line would have a definite value (resistive)

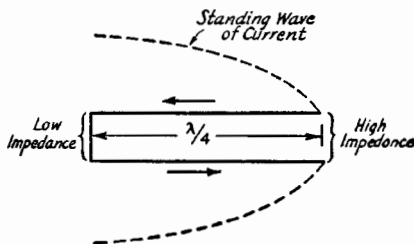

Fig. 315 — Standing wave and instantaneous current conditions of a folded resonant-line circuit.

The Radio Amateur's Handbook

determined, practically, by the size of the wires, their spacing and the dielectric between them. This impedance is called the *surge impedance* or *characteristic impedance*. If this line were cut and it was terminated, at a definite distance from the input end, by an impedance equal to the surge impedance of the infinite line, again there would be no reflections from the far end and, consequently, no standing waves.

Resonant lines and lines terminated in their characteristic impedance find much application in coupling transmitters and receivers to antenna systems.

● COUPLED CIRCUITS

Resonant circuits are not used alone in very many instances but are usually associated with other resonant circuits or are *coupled* to other circuits. It is by such coupling that energy is transferred from one circuit to another. Such coupling may be *direct*, as shown in A, B and C of Fig. 316, utilizing as the mutual coupling element, inductance (A), capacitance (B) or resistance (C). These three types of coupling are known as *direct inductive*, *direct capacitive*, or *direct resistive*, respectively. Current circulating in one LC branch flows through the common element (C, R or L) and the voltage developed across this element causes current flow in the other CL branch. Other types of coupling are the *indirect capacitive* and *transformer* or *inductive* shown below the others. The coupling most common in high-frequency circuits is of the latter type. In such an arrangement the coupling value may be changed by changing the number of active turns in either coil or by changing the relative position of the coils (distance or angle between them).

All of the above coupling schemes may be classified as either tight or loose. Coupling cannot, however, be measured simply in "inches" separation of coils. The separation between the coils (distance and angle between axes) and the inductance in each determine the *coefficient of coupling*.

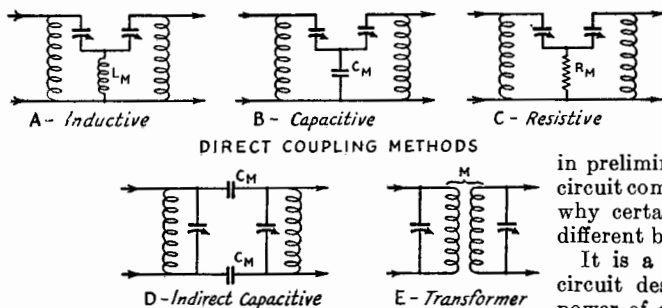

Fig. 316 — Basic types of circuit coupling.

Coefficient of Coupling (*k*)

The common property of two coils which gives transformer action is their *mutual inductance* (*M*). Its value is determined by self-inductance of each of the two coils and their position with respect to each other. In practice, the coupling between two coils is given in terms of their *coefficient of coupling*, designated by *k*. The coupling is maximum (unity or 100%) when all of the lines of force produced by one coil link with all of the turns of the other. With air-core coils in radio-frequency circuits the coupling is much "looser" than this, however. It is generally expressed by the following relation:

$$k = \frac{M}{\sqrt{L_1 L_2}}$$

in which *k* is the coefficient of coupling expressed either as a decimal part of 1, or, when multiplied by 100, as a percentage; *M* is the mutual inductance; *L*₁ is the self-inductance of one coil; and *L*₂ is the self-inductance of the other coil. *M*, *L*₁ and *L*₂ must be in the same units (henrys, millihenrys or microhenrys).

Critical coupling is that which gives the maximum transfer of energy from the primary to the secondary. However, the sharpness of resonance for the combination is considerably lessened under this condition. With coupling greater than critical, the resonance curve has two "humps" appreciably separated. For good selectivity the coupling is therefore made considerably less than the critical value, even though this reduces the amplification or gain.

Impedance Matching

It should be kept in mind that, as has been previously mentioned, both single resonant circuits and coupled circuits are used in conjunction with other circuit elements. These other elements introduce resistance into the resonant circuits, and modify the constants that they would have by themselves. In practice it is seldom possible for the amateur to precalculate the effect of such reactions, since the

other quantities are usually unknown. In any case, it is usually necessary to arrive at "best conditions" by the practical process of adjustment. However, the foregoing general information is helpful

in preliminary design or choice of tuned circuit combinations, and in understanding why certain changes are likely to cause different behavior in circuit performance.

It is a well-known principle in radio circuit design that the maximum gross power of a generator, such as a vacuum tube, will be delivered to its load when the

Electrical and Radio Fundamentals

load resistance is equal to the internal resistance of the generator. In other words, maximum power would be taken from the generator when its resistance was exactly *matched* by the load resistance. Although this particular statement is literally true, it might not describe the most desirable condition of loading. For one thing, the efficiency would be only 50%, half the power being consumed in the generator and half in the load. From the principle, however, has grown up a system of more or less standard practice in designing radio circuits which comes under the broad heading of *impedance matching*. The term means, generally, that the load impedance presented to the source is transformed to suit given requirements. This is accomplished by transformers and other coupling devices.

Iron-core transformers are widely used for coupling between load and vacuum-tube in audio-frequency amplifiers, for instance. In such cases the value of proper load resistance (load impedance) for maximum undistorted power output will be given for the tube. This load resistance, it will be noted, is not the same as the rated *plate* resistance of the tube, which is equivalent to its internal resistance as a generator. A second figure will be given for the actual impedance of the load device to which the tube must supply undistorted power. The matching of this load to the given requirements of the tube is the job of the coupling transformer, the job being to make the actual impedance of the load device appear as the rated load impedance of the tube, so far as the tube is concerned. This requires that the transformer have the proper ratio of secondary to primary turns. *The turn ratio will be equal to the square root of the impedance ratio.*

$$\frac{N_s}{N_p} = \sqrt{\frac{Z_s}{Z_p}}$$

where N_s and N_p are the numbers of secondary and primary turns, Z_s is the impedance of the load device and Z_p is the rated load resistance of the tube. *This will also be the voltage ratio of the transformer.*

Transformers are also used to provide proper impedance matching in radio-frequency circuits, although here the problem is not one of simply choosing a calculated turn ratio. Rather, the right condition is arrived at by adjustment of turns and distance between coils.

Matching by Tapped Circuits

In addition to impedance matching by inductive coupling with tuned circuits, frequent use is made of tapped resonant circuits. Two methods for parallel resonant circuits are illustrated in Fig. 317. In one case (A) the tapping is across part of the coil, while in the

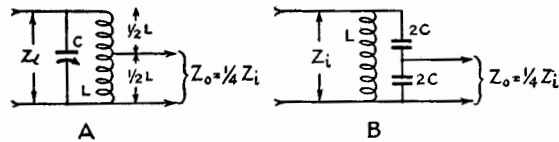

Fig. 317 — Methods of tapping the parallel impedance of resonant circuits for impedance matching.

other (B) it is across one of two tuning condensers in series. In both cases *the impedance between the tap points will be to the total impedance practically as the square of the reactance between the tap points is to the total reactance of the branch in which the tapping is done.* That is, if the coil is tapped at a point where the reactance between the tap points is one-half the total inductive reactance, the impedance between these points will be $(\frac{1}{2})^2$ or one-fourth the total parallel impedance of the circuit. The same will apply if the tap is made across one of two equal capacitance condensers connected in series. If the condenser across which the tap was made had twice the capacitance of the other, however, the impedance Z_o would be one-ninth the total, since the reactance between the tap points would then be but a third — capacitive reactance decreasing as the capacitance is increased.

Link Coupling

Another coupling arrangement used for impedance matching radio-frequency circuit is that known as *link coupling*. It is used for transferring energy between two tuned circuits which are separated by space so that there is no direct mutual coupling between the two coils. It is especially helpful in minimizing incidental capacitive coupling between the two circuits due to the distributed capacitance of the windings, thereby minimizing the transfer of undesired harmonic components of the desired fundamental. Two typical versions of link coupling are shown in Fig. 318. Both represent an impedance step-down from one tuned circuit to the coupling line, and then an im-

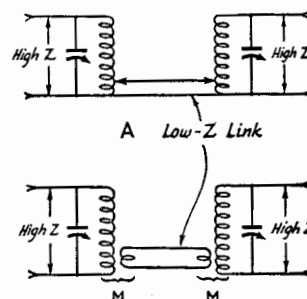

Fig. 318 — Methods of using link coupling for impedance matching.

The Radio Amateur's Handbook

pedance step-up from the line to the other tuned circuit.

The arrangement of Fig. 318-A will be recognized as an adaptation of the impedance-tapping method previously shown in Fig. 317-A. It is sometimes called auto-transformer link coupling, because the link turns are also included in the tuned-circuit turns. The arrangement of 318-B differs only in that the link turns are separate and inductively coupled to the tuned-circuit turns. The latter system is somewhat more flexible in adjustment than the tapping method, since the coupling at either end of the line can be adjusted in small steps by moving the link turns with respect to the tuned-circuit coils.

● COMPLEX WAVES

Alternating currents having the ideal sine-wave form are practically never found in actual radio circuits, although waves closely approximating the perfectly sinusoidal can be generated with laboratory-type equipment. In the usual case, such a current actually has components of two or more frequencies integrally related, as shown in Fig. 319. Any complex wave-form can be resolved into a *fundamental* frequency and a number of whole-number multiple frequencies called *harmonics*. The harmonic of double frequency is the second harmonic, one of triple frequency the third, etc. Although the wave resulting from the combination is non-sinusoidal the wave-form of each component taken separately has the sine-wave form. The resultant form of the complex wave will depend on the number and amplitude of the harmonics and the phase angles between the harmonics and the fundamental.

If a current of pure sine-wave form is passed through some electrical device that *distorts* the wave-form, i.e., changes its shape from the original, the resultant current must necessarily be made up of the fundamental plus harmonic

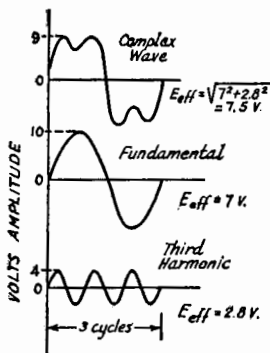

Fig. 319 — A complex wave and its sine-wave components.

frequencies, and it is said that the device "distorted" the wave-form of generated harmonics. Under certain conditions, vacuum-tube amplifiers will distort the wave-form and generate harmonics.

The effective value of the current or voltage for such a complex wave will not be the same as for a pure sine wave of the same maximum value. Instead, the *effective value for the complex wave will be equal to the square root of the sum of the squares of the effective values of the individual frequency components*. That is,

$$E = \sqrt{E_1^2 + E_2^2 + E_3^2}$$

where E is the effective value for the complex wave, and $E_1, E_2,$ etc., are the effective values of the fundamental and harmonics. The same relation also applies where currents of different frequencies not harmonically related flow in the same circuit.

Combined A.C. and D.C.

There are many practical instances of simultaneous flow of alternating and direct current in a circuit. When this occurs there is a *pulsating*

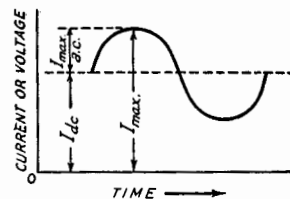

Fig. 320 — Pulsating current composed of alternating current superimposed on direct current.

ing current and it is said that an alternating current is *superimposed* on a direct current. As shown in Fig. 320, the maximum value is equal to the d.c. value plus the a.c. maximum, while the minimum value (on the negative a.c. peak) is the difference between the d.c. and the maximum a.c. values. If a d.c. ammeter is used to measure the current, only the average or direct-current component will be indicated. An a.c. meter, however, will show the effective value of the combination. But this effective value is *not* the simple arithmetical sum of the effective value of the a.c. and the d.c., *but is equal to the square root of the sum of the effective a.c. squared and the d.c. squared*.

$$I = \sqrt{I_{ac}^2 + I_{dc}^2}$$

where I_{ac} is the effective value of the a.c. component, I is the effective value of the combination and I_{dc} is the average (d.c.) value of the combination. If the a.c. component is of sine-wave form, its maximum value will be its effective value, as determined above, multiplied by 1.414. If the a.c. component is not sinusoidal the maximum value will have a

Electrical and Radio Fundamentals

different ratio to the effective value, of course, depending on its wave-form, as discussed in the preceding section.

Beats

If two or more alternating currents of different frequencies are present in a normal circuit, they have no particular effect upon one another and, for this reason, can be separated again at any time by the proper selective circuits. However, if two (or more) alternating currents of different frequencies are present in an element having unilateral or one-way current flow properties, not only will the two original frequencies be present in the output but also currents having frequencies equal to the sum, and difference, of the original frequencies. These sum and difference frequencies are called the *beat* frequencies. For example, if frequencies of 2000 and 3000 kc. are present in a normal circuit, only those two frequencies exist, but if they are passed through a unilateral element (such as a properly-adjusted vacuum tube) there will be present in the output not only the two original frequencies of 2000 and 3000 kc. but also currents of 1000 ($3000 - 2000$) and 5000 ($3000 + 2000$) kc. Proper selective circuits can select the desired beat frequency.

There are two important things to remember about beats: (1) it is necessary to have a unilateral (or non-linear) element before beats can be generated, and (2) both sum and difference frequencies exist in the output, as well as the original frequencies.

● ELECTRONS IN MOTION—RADIO CIRCUITS AND COMMUNICATION

It has already been briefly mentioned that when alternating current reaches a frequency of 15,000 cycles or higher not all of the energy stored in the magnetic field of a coil (or the electrostatic field of a condenser) returns, but that some of the energy escapes in the form of *electromagnetic radiation*. In other words, the energy is radiated into space. Not much escapes from the conventional coil or condenser, but a great deal is radiated from a resonant wire, as mentioned before. As the frequency is increased, more and more of the total energy is radiated, and most radio antennas at the higher frequencies radiate practically all of the energy introduced into them. This radiation through space is the basis of all radio communication.

You now have the complete picture of the family of moving electrons, or electricity. Electrons at rest in the form of static (meaning *still*) charges; electrons moving in one direction forming direct-current flow; electrons moving back and forth at regular periods to form alternating current, and, when the frequency becomes great enough, radiating their energy out into space. One thing is important: The

radio-frequency currents in the antenna set up *fields of energy* which travel through space—the electrons themselves are not hurled through the air. Radio waves travel through space with the speed of light, roughly about 186,000 miles per second, or seven times around the world in one second. Normally traveling in straight lines from the radiating point, radio waves can be bent or refracted in the upper atmosphere and thus transmitted to a point on the opposite side of the earth.

Wiring Diagrams

The connections for the component parts of any piece of electrical or radio equipment are given in a *wiring* or *circuit diagram*. Reference to the table of symbols will allow one to become familiar with the symbols used to represent the various components. It should be remembered that, unless it is so labeled, a wiring diagram is not necessarily a "picture diagram" and therefore does not show the relative position of parts and wires. Often the circuit diagram will represent a layout of parts that allows short, and hence desirable, leads but this is not always the case. In any event, the sequence of connections as shown in the wiring diagram is not necessarily the sequence that need be followed, and the relative length of leads shown on the wiring diagram does not necessarily represent the relative length of leads in the set. Wires carrying radio-frequency should be kept short; connections carrying direct or low-frequency alternating current can usually be any practical length without impairing the performance.

Grounds

Frequent reference will be made to "ground" in discussing circuits in later chapters, and nearly all wiring diagrams will show a ground connection. It should be understood from the start that a ground connection does not necessarily mean that connection to the earth is essential for the proper operation of the equipment, although it is sometimes necessary in the case of high-gain audio amplifiers and some receivers. Ground in a circuit normally means the voltage-reference level of the circuit, and it is a point in the circuit that can be connected to the earth without any change in the operation of the equipment. In a receiver or transmitter, the metal chassis is usually used as the ground for all d.c. voltages, and any a.c. or r.f. circuit can be brought to ground by direct connection or, when a direct connection would short the d.c. circuit, by a condenser of suitable size.

A Complete Radio System

Radiation through space is the basis of all radio communication, but means must be

The Radio Amateur's Handbook

provided for generating the signal and reclaiming it at the receiving end. The transmitting station requires, first of all, a means for generating the radio-frequency energy, and this is done by converting direct current or low-frequency alternating current power into radio frequency by means of vacuum tubes and their associated circuits, as will be explained in detail later. The radio-frequency energy is fed into a radiating system, or antenna. However, in order to transmit intelligence, that intelligence must first be superimposed upon the radio-frequency energy, and this is done by either varying the amplitude of the output in accordance with the voice frequencies of the operator picked up by microphone and amplified, in the case of radiotelephone operation, or by turning the output on and off to form the dots and dashes of the Morse radio code that correspond to the letters of the words that the operator wishes to transmit. Thus the energy radiated from the antenna serves as a carrier for the intelligence.

At the receiving station, an antenna has induced in it currents that correspond to those in the transmitting antenna, although millions of times weaker. These currents are introduced into selective circuits which make it possible to select the desired signal out of all that exist in space at any instant, and they are amplified by passing them through suitable vacuum-tube amplifiers which build up the energy level. But to make the signal audible it must be *detected*, which means running the amplified energy through a proper vacuum tube which strips the radio-frequency from the signal and leaves only currents which are varying exactly as the voice currents from the microphone at the transmitter varied. In the case of radiotelegraph transmission, an oscillator near the frequency of the signal *beats* with the signal in the detector to generate a beat frequency

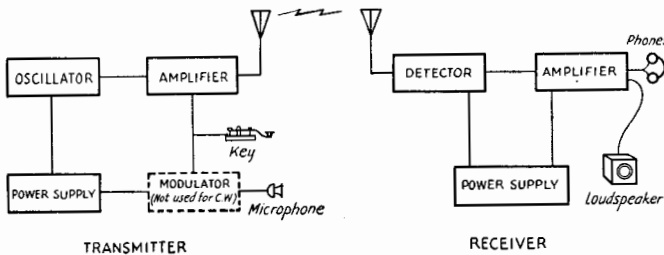

Fig. 321 — A complete radio system. The power supply of the transmitter furnishes power that is changed to radio-frequency energy and fed to the antenna. The oscillator determines the frequency of the radio-frequency power. A modulator, for voice work, or a key for radiotelegraph, varies the power fed to the amplifier and hence the power reaching the antenna. Weak radio-frequency currents induced in the receiving antenna are detected and amplified, and are heard in headphones or a loudspeaker.

within the audio range which of course only appears when the signal is coming through and hence varies exactly as the dots and dashes formed at the transmitter. The audible signal may be amplified after detection and made audible by feeding it into headphones or a loud-speaker.

● VACUUM TUBES

As mentioned before, practically all of the vacuum tubes used in radio work depend upon thermionic conduction for their operation. The simplest type of vacuum tube is that shown in Fig. 322. It has but two elements, cathode and plate, and is therefore called a *diode*. The cathode is heated by the "A" battery and emits electrons which flow to the plate when the plate is at a positive potential with respect to the cathode. The "A" battery furnishes no power to the cathode-plate circuit — its only

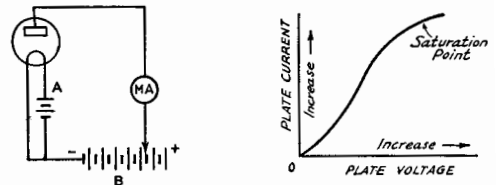

Fig. 322 — The diode or two-element tube and a typical characteristic curve.

function is to heat the cathode hot enough to emit electrons freely. The tube is a conductor in one direction only. If a battery is connected with its negative terminal to cathode and positive to plate (the "B" battery in Fig. 322) this flow of electrons will be continuous. But if a source of alternating voltage is connected between the cathode and plate, then electrons will flow only on the positive half-cycles of alternating voltage; there will be no electron flow during the half cycle when the plate is negative. Thus the tube can be used as a *rectifier*, to change alternating current to pulsating direct current. This alternating current can be anything from the 60-cycle kind to the highest radio frequencies, making it possible to use the diode as a rectifier in power supplies furnishing direct current for our transmitters and receivers or to use it as a rectifier (detector) of radio-frequency current in receivers.

The performance of the tube can be reduced to easily-understood terms by making use of what are known as *tube characteristic curves*. A typical characteristic curve for a diode is shown at the right in Fig. 322. It shows the

Electrical and Radio Fundamentals

currents flowing between the various tube elements and cathode (usually only between plate and cathode, since the plate current is of chief interest in determining the output of the tube) with different d.c. voltages applied to the elements. The curve of Fig. 322 shows that, with fixed cathode temperature, the plate current increases as the voltage between cathode and plate is raised. For an actual tube the values of plate current and plate voltage would be plotted along their respective axes.

With the cathode temperature fixed, the total number of electrons emitted is always the same regardless of the plate voltage. Fig. 322 shows, however, that less plate current will flow at low plate voltages than when the plate voltage is large. With low plate voltage only those electrons nearest the plate are attracted to the plate. The electrons in the space near the cathode, being themselves negatively charged, tend to repel the similarly-charged electrons leaving the cathode surface and cause them to fall back on the cathode. This is called the *space charge* effect. As the plate voltage is raised, more and more electrons are attracted to the plate until finally the space charge effect is completely overcome and all the electrons emitted by the cathode are attracted to the plate, and a further increase in plate voltage can cause no increase in plate current. This is called the *saturation point*.

Triode Action — Amplification

If a third element, called the *control grid* or simply the *grid*, is inserted between the cathode and plate of the diode the space-charge effect can be controlled. The tube then becomes a *triode* (three-element tube) and is useful for more things than rectification. The grid is usually in the form of an open spiral or mesh of fine wire. With the grid connected externally to the cathode and with a steady voltage from a d.c. supply applied between the cathode and plate (the positive of the "B" supply is always connected to the plate), there will be a constant flow of electrons from cathode to plate, through the openings of the grid, much as in the diode. But if a source of variable voltage is connected between the grid and cathode there will be a variation in the flow of electrons from cathode to plate (a variation in plate current) as the voltage on the grid changes about a mean value. When the grid is made less negative (more positive) with respect to the cathode, the space charge is partially neutralized and there will be an increase in plate current; when the grid is made more negative with respect to the cathode, the space charge is reinforced and there will be a decrease in plate current. When a resistance or impedance is connected in the plate circuit, the variation in plate current will cause a variation

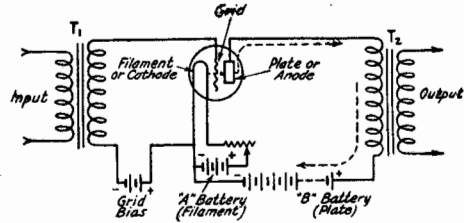

Fig. 323 — A typical audio-frequency amplifier using a triode tube.

in voltage across this load that will be a magnified version of the variation in grid voltage. In other words there is *amplification* and the tube is an *amplifier*.

The measure of the amplification of which a tube is capable is known as its *amplification factor*, designated by μ (mu). μ is the ratio of plate-voltage change required for a given change in plate current to the grid-voltage change necessary to produce the same change in plate current. Another important characteristic is the *plate resistance*, designated r_p . It is the ratio, for a fixed grid voltage, of a small plate voltage change to the plate current change it effects. It is expressed in *ohms*. Still another important characteristic used in describing the properties of a tube is *mutual conductance*, designated by g_m and defined as the rate of change of plate current with respect to a change in grid voltage. The mutual conductance is a rough indication of the design merit of the tube. It is expressed in *micromhos*, the ratio of amplification factor to plate resistance, multiplied by one million. These tube characteristics are inter-related and are dependent primarily on the tube structure.

The operation of a vacuum tube amplifier is graphically represented in elementary form in Fig. 324. The sloping line represents the variation in plate current obtained at a constant plate voltage with grid voltages ranging from a value sufficiently negative to reduce the plate current to zero to a value slightly positive. Bear in mind that grid voltage is with reference to the cathode or filament. Notable facts about this curve are that it is essentially a straight line (is *linear*) over the middle section and that it bends towards the bottom (near *cut off*) and near the top (*saturation*). In other words, the variation in plate current is directly proportional to the variation in grid voltage over the region between the two bends. With a fixed grid voltage (*bias*) of proper value the plate current can be set at any desired value.

Tube characteristics of the type shown in Fig. 324 may be of either the *static* or *dynamic* type. Static characteristics show the plate current that will flow at specific grid and plate voltages in the absence of any output device

The Radio Amateur's Handbook

in the plate circuit for transferring the plate current variation to an external circuit.

Dynamic characteristics are more useful. In plotting this form of curve a resistance, R_p , is connected in series with the battery and

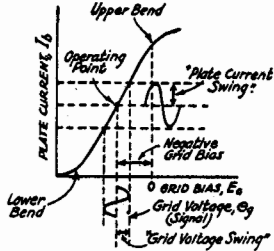

Fig. 324—Operating characteristics of a vacuum-tube amplifier. Class-A amplifier operation is depicted.

plate-cathode circuit of the tube; it represents a load or output circuit. Plate current flowing through R_p causes a voltage drop in the resistor; if the grid voltage is varied, causing a variation in plate current, the voltage drop across R_p likewise will vary. If an alternating voltage is applied to the grid-cathode circuit the alternating plate current causes an alternating voltage to be developed across R_p . This voltage is the useful output of the tube.

The load impedance or load resistance, R_p , may be an actual resistor or a device having an impedance, at the frequency being amplified, of a value suitable for the plate circuit of the tube. In general, there will be one value of R_p which will give optimum results for a given type of tube and set of operating voltages; its value also depends upon the type of service for which the amplifier is designed. If the impedance of the actual device used is considerably different from the optimum load impedance, the tube and output device must be coupled through a transformer having a turns ratio such that the impedance reflected into the plate circuit of the tube is the optimum value.

Distortion

With negative grid bias as shown in Fig. 324 this point (the operating point) comes in the middle of the linear region. If an alternating voltage (signal) is now applied to the grid in series with the grid bias, the grid voltage swings more and less negative about the mean bias voltage value and the plate current swings up (positive) and down (negative) about the mean plate current value. This is equivalent to an alternating current superimposed on the steady plate current. At this operating point it is evident that the plate current wave shapes are identical reproductions of the grid voltage wave shapes and will remain so as long as the grid voltage amplitude does not reach values

sufficient to run into the lower- or upper-bend regions of the curve. If this occurs the output waves will be flattened or distorted. If the operating point is set towards the bottom or the top of the curve there will also be distortion of the output wave shapes because part or all of the lower or upper half-cycles will be cut off.

Whenever the bias is adjusted so that the tube works over a non-linear portion of its characteristic curve, distortion will take place and the output wave-form will not duplicate the wave-form of the voltage introduced at the grid. This characteristic of non-linearity of an amplifier is useful in many applications (to be described later) and is an undesirable feature at other times. The distortion will take the form of harmonics added to the original wave, as explained previously. If the exciting signal is a single sine wave, the output wave, when distortion is present, will consist of the fundamental plus second and higher harmonics.

Parallel and Push-Pull Connections

When it is necessary to obtain more power output than one tube is capable of giving, without going to a larger tube structure, two or more tubes may be connected in parallel, in which case the similar elements in all tubes are connected together. The power output will then be in proportion to the number of tubes used; the exciting voltage required, however, is the same as for one tube.

An increase in power output also can be secured by connecting two tubes in push-pull, the grids and plates of the two tubes being connected to opposite ends of the circuit, respectively. Parallel and push-pull operation are illustrated in Fig. 325. A "balanced" circuit, in which the cathode returns are made to the midpoint of the input and output devices, is necessary with push-pull operation. An alternating current flowing through the primary of the input transformer in the push-pull diagram will cause an alternating voltage to be

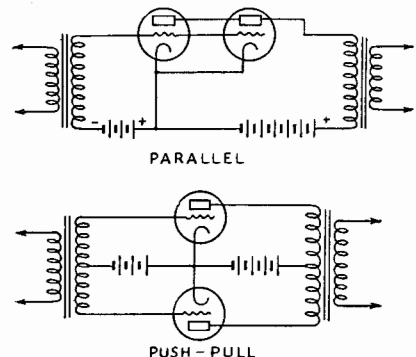

Fig. 325—Parallel and push-pull amplifier connections.

Electrical and Radio Fundamentals

induced in the secondary winding; since the ends of the winding will be at opposite potentials with respect to the cathode connection, the grid of one tube is swung positive at the same instant that the grid of the other is swung negative. Hence, in any push-pull-connected stage, the voltages and currents of one tube are "out of phase" with those of the other tube. The plate current of one tube therefore is rising while the plate current of the other is falling, hence the name "push-pull." In push-pull operation the even-harmonic (second, fourth, etc.) distortion is cancelled in the symmetrical plate circuit, so that for the same output the distortion will be less than with parallel operation. It follows that for a given degree of distortion the push-pull amplifier is capable of delivering somewhat more power than a parallel amplifier.

R.F. and A.F. Voltage and Power Amplifiers

The major uses of vacuum tube amplifiers in radio work are to amplify at audio frequencies (approximately 30 to 15,000 cycles per second) and to amplify at radio frequencies (up to 60,000 kc. or higher). The audio-frequency amplifier is generally used to amplify without discrimination at all frequencies in a wide range (say from 100 to 3000 cycles for voice communication), and is therefore associated with non-resonant or untuned circuits which offer a uniform load over the desired range. The radio-frequency amplifier, on the other hand, is generally used to amplify selectively at a single radio frequency, or over a small band of frequencies at most, and is therefore associated with resonant circuits tunable to the desired frequency.

An audio-frequency amplifier may be considered a *broad-band amplifier*; most radio-frequency amplifiers are relatively narrow-band affairs.

Amplifiers may be divided broadly into two general types, those whose chief purpose is to give a greatly magnified reproduction of the input signal voltage across the plate load but not necessarily much power, and those intended to deliver a relatively large amount of power to a load (a loud-speaker, in the case of an audio amplifier, or an antenna, in the case of a radio-frequency amplifier). The former is a *voltage amplifier*, while the latter is a *power amplifier*.

In audio circuits, the power tube or output

tube in the last stage usually is designed to deliver a considerable amount of audio power, while requiring but negligible power from the input or exciting signal. The *power amplification* — ratio of output power to power supplied the grid circuit — is consequently very high. Such tubes generally require a large grid voltage swing for full power output, however, so that the *voltage amplification* — ratio of output voltage to signal voltage — is quite low. To get the voltage swing required for the grid of such a tube voltage amplifiers are used, employing tubes of high μ which will greatly increase the voltage amplitude of the signal. Although such tubes are capable of relatively high voltage output, the power obtainable from them is small. Voltage amplifiers are used in the radio-frequency stages of receivers as well as in audio amplifiers.

Bias

A fixed voltage is applied to the grid of a tube, to determine the point on the tube characteristic at which the tube will operate. This fixed voltage is called the *grid bias*, and it can be obtained in several different ways. The simplest is to use a battery or power supply of the proper voltage connected in the grid circuit of the tube, as shown in Fig. 326-A.

Another method is to connect a resistor in the cathode circuit of the tube as in Fig. 326-B. The voltage drop caused by the flow of plate current through the resistor is used as the source of bias potential. This is called *cathode bias*. In multi-element tubes, the current through this resistor will be the summation of the plate and screen (and suppressor) currents. The condenser across the resistor acts as a low-impedance path for the plate current and must have a value that offers a low-impedance path to the frequency of the plate current. If the condenser is omitted or has too small a value, the changes in plate current will change the bias at the same time, and these changes work against the changes in plate current caused by the signal voltage on the grid, reducing the amplification of the tube. This effect is called *degeneration*.

Still another type of bias, used when the grid is driven positive by the signal voltage, is shown in Fig. 326-C. This is called *grid-leak bias*. The grid acts as the plate of a diode and, every time it is driven positive with respect to the cathode, it draws current as any diode does.

Fig. 326 — Three methods of obtaining grid bias. Battery bias is shown at A, cathode bias at B, and grid-leak bias at C.

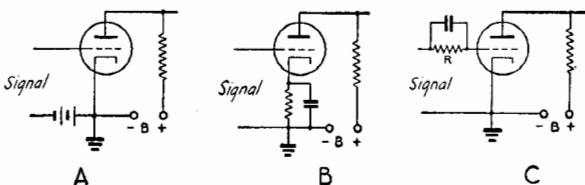

The Radio Amateur's Handbook

This current, flowing through the grid-leak resistor R , causes a potential drop across the resistor that supplies the bias voltage. The condenser furnishes a low-impedance path for the signal, similar to its function in the case of cathode bias. This bias system can only be used when the grid is driven positive, and requires that the amplifier or source furnishing the signal (*excitation*) at the grid supply power to the circuit. The grid-leak bias system is used in some forms of detectors (explained later) and in oscillators and transmitter stages.

The proper value of cathode resistor can be easily calculated from Ohm's Law.

$$\text{For cathode bias, } R_c = \frac{E \times 1000}{I}$$

where R_c = cathode bias resistor in ohms

E = desired bias voltage

I = total d.c. cathode current in milliamperes

E and I can be found from the tube tables. Screen- and suppressor-grid currents should be included with the plate current in multi-element tubes to obtain the total cathode current, and also the control-grid current if the control grid is driven positive during operation.

$$\text{For grid-leak bias, } R_{gl} = \frac{E \times 1000}{I}$$

where R_{gl} = grid-leak resistance in ohms

E = desired bias voltage

I = d.c. grid current, in milliamperes

When two tubes are operated in push-pull or parallel and use a common cathode- or grid-leak resistor, the value of resistance becomes one-half what it would be for one tube.

Fundamental Amplifier Classifications Class A

An amplifier operated as shown in Fig. 324 in which the output wave shape is a faithful reproduction of the input wave shape, is known as a *Class-A* amplifier.

Certain operating conditions distinguish the *Class-A* amplifier. As generally used, the grid never is driven positive with respect to the cathode by the exciting signal, and never is driven so far negative that plate-current cut-off is reached. The plate current is constant both with and without an exciting signal. The chief characteristics of the *Class-A* amplifier are low distortion, low power output for a given size of tube, and a high power-amplification ratio. The plate efficiency — ratio of a.c. output power to steady d.c. input power — is relatively low, being in the vicinity of 20 to 35 percent at full output, depending upon the design of the tube and the operating conditions.

Class-A amplifiers of the power type find application as output amplifiers in audio systems, operating loud speakers in radio receivers

and public-address systems, and as modulators in radiotelephone transmitters. *Class-A* voltage amplifiers are found in the stages preceding the power stage in such applications, and as radio-frequency amplifiers in receivers.

Class-B Amplifiers

The *Class-B* amplifier is primarily one in which the output current, or alternating component of the plate current, is proportional to the amplitude of the exciting grid voltage. Since power is proportional to the square of the current, the power output of a *Class-B* amplifier is proportional to the square of the exciting grid voltage.

The distinguishing operating condition in *Class-B* service is that the grid bias is set so that the plate current is relatively low without

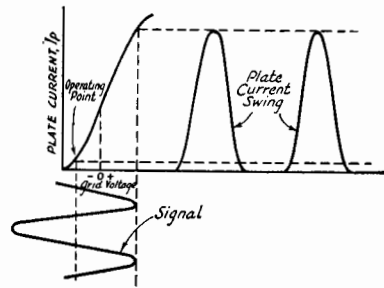

Fig. 327 — Operation of the *Class-B* amplifier.

excitation; the exciting signal amplitude is such that the entire linear portion of the tube's characteristic is used. Fig. 327 illustrates *Class-B* operation with the tube biased practically to cut-off. In this operating condition plate current flows only during the positive half-cycle of excitation voltage. No plate current flows during the negative swing of the excitation voltage. The shape of the plate current pulse is essentially the same as that of the positive swing of the signal voltage. Since the plate current is driven up toward the saturation point, it is usually necessary for the grid to be driven positive with respect to the cathode during part of the grid swing. Grid current flows, therefore, and the driving source must furnish power to supply the grid losses.

Class-B amplifiers are characterized by medium power output, medium plate efficiency (50% to 60% at maximum signal) and a moderate ratio of power amplification. They are used for both audio and radio-frequency amplification. As radio frequency amplifiers they are used as *linear amplifiers* to raise the output power level in radiotelephone transmitters after modulation has taken place.

For audio-frequency amplification, two tubes must be used to permit *Class-B* operation. A second tube, working alternately with

Electrical and Radio Fundamentals

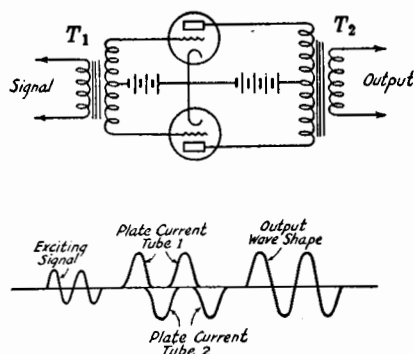

Fig. 328 — The Class-B audio amplifier, showing how the outputs of the two tubes are combined to give distortionless amplification.

the first, must be included so that both halves of the cycle will be present in the output. A typical method of arranging the tubes and circuit to this end is shown in Fig. 328. The circuit resembles that of the push-pull Class-A amplifier; the difference lies in the method of operation. The signal is fed to a transformer T_1 , whose secondary is divided into two equal parts, with the tube grids connected to the outer terminals and the grid bias fed in at the center. A transformer T_2 with a similarly-divided primary is connected to the plates of the tubes. When the signal swing in the upper half of T_1 is positive, Tube No. 1 draws plate current while Tube No. 2 is idle; when the lower half of T_1 becomes positive, Tube No. 2 draws plate current while Tube No. 1 is idle. The corresponding voltages induced in the halves of the primary of T_2 combine in the secondary to produce an amplified reproduction of the signal wave-shape with negligible distortion. The Class-B amplifier is capable of delivering much more power for a given tube size than a Class-A amplifier.

Class-C Amplifiers

The third type of amplifier is that designated as Class C. Fundamentally, the Class-C amplifier is one operated so that the alternating component of the plate current is directly proportional to the plate voltage. The output power is therefore proportional to the square of the plate voltage. Other characteristics inherent to Class-C operation are high plate efficiency, high power output, and a relatively low power-amplification ratio.

The grid bias for a Class-C amplifier is ordinarily set at approximately twice the value required for plate current cut-off without grid excitation. As a result, plate current flows during only a fraction of the positive excitation cycle. The exciting signal should be of sufficient amplitude to drive the plate current to

the saturation point, as shown in Fig. 329. Since the grid must be driven far into the positive region to cause saturation, considerable numbers of electrons are attracted to the grid at the peak of the cycle, robbing the plate of some that it would normally attract. This causes the droop at the upper bend of the characteristic, and also causes the plate current pulse to be indented at the top, as shown. Although the output wave-form is badly distorted, at radio frequencies the distortion is largely eliminated by the filtering or flywheel effect of the tuned output circuit.

Class-C amplifiers are used principally as radio-frequency power amplifiers, and have very little audio-frequency application. Although requiring considerable driving power because of the relatively large grid swing and grid-current flow, the high plate efficiency of the Class-C amplifier makes it an effective generator of radio-frequency power.

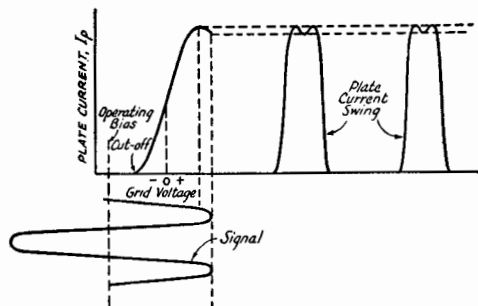

Fig. 329 — Class-C amplifier operation.

Other Amplifier Classifications

Since the three fundamental amplifier classifications represent three distinct steps in the operation of vacuum tubes, there are intermediate steps which partake of the nature of two of the classifications although not adhering strictly to either. Such "midway" methods of operation can be classified as "AB" and "BC." Only the "AB" type of operation is in general use. The Class-AB amplifier is a push-pull amplifier in which each tube operates during more than half but less than all the exciting-voltage cycle. Its bias is set so that the tubes draw more plate current than in Class-B operation, but less than they would for Class-A. The plate current of the amplifier varies with the signal voltage, but not as much as in Class-B.

The efficiency and output of the Class-AB amplifier lie between those obtainable with pure Class-A or Class-B operation. Class-AB amplifiers tend to operate Class-A with low signal voltages and Class-B with high signal voltages, thus overcoming the chief objection to Class-B operation — the distortion

The Radio Amateur's Handbook

present with low-input-signal voltages. The Class-AB amplifier is widely used where it is necessary to obtain a power output of considerable magnitude with a minimum of distortion.

● GENERATING RADIO FREQUENCY POWER

Because of its ability to amplify, the vacuum tube can oscillate, or generate alternating current power. To make it do this, it is only necessary to couple the plate (output) circuit to the grid (input) circuit so that the alternating voltage supplied to the grid of the tube is opposite in phase to the voltage on the plate. Typical circuits for this condition are shown in Fig. 330. In *A* the feed-back coupling between the plate and grid circuits is inductive (by means of coils), while in *B* the coupling is capacitive (through a condenser). In the circuit of *A* the frequency of oscillation will be very nearly the resonant frequency of the

in effect detached from the carrier wave and made audible. Taking the case of a modulated wave, such as in radiotelephone transmission, we find there are three ways of operating tubes to perform the function of demodulation. All are essentially the process of *rectification*, in which the radio-frequency input is converted into direct current which in turn varies in accordance with the audio-frequency modulation envelope. The first type of detector is the diode, or simple rectifier, the operation of which already has been explained. Multi-element tubes can be operated either as "grid" or "plate" detectors, depending upon whether the rectification takes place in the grid or plate circuits.

Plate Detectors

The circuit arrangement of a typical plate detector is shown at *A* of Fig. 331. Its operating characteristics are illustrated at *A* of Fig. 332. The circuit L_1C_1 is tuned to resonance with the radio frequency and the voltage developed across it is applied between the grid and cathode in series with the grid-bias battery. A headset or the primary of a transformer is connected in the plate circuit, a small fixed condenser *C* being connected across the plate load to by-pass radio frequency. As shown at *A* in Fig. 332, the negative grid bias voltage is such that the operating point is in the lower-bend region of the curve, near cut-off. With a modulated signal as shown there will be a variation in plate current conforming to the average value of the positive half-cycles of radio frequency. This variation corresponds to the envelope, representing an audio-frequency current super-imposed on the steady plate current of the tube, and constitutes the useful audio output of the detector. When this pulsating current flows through the 'phones their diaphragms vibrate in accordance with it to give a reproduction of the modulation put on the signal at the transmitter.

Grid Detectors

The circuit arrangement of a triode used as a *grid detector* (also called *grid leak detector*) is shown in *B* of Fig. 331. An input circuit tuned to the frequency of the radio wave is connected so that the r.f. voltage developed across it is applied between the grid and cathode. However, there is no fixed negative grid bias, as in the case of the plate detector. Instead a small fixed capacity (*grid condenser*) and resistor of high value (*grid leak*) are connected between tuned circuit and grid. The plate circuit is the same as for the plate detector.

The action of the grid detector is illustrated by the grid voltage-grid current curve of Fig. 332-B. A modulated radio-frequency voltage applied to the grid swings it alternately positive and negative about the operating

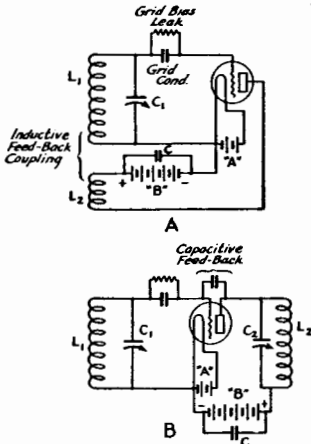

Fig. 330 — Two general types of oscillator circuits.

tuned circuit L_1C_1 , while in *B* the frequency of oscillation will be determined jointly by L_1C_1 and L_2C_2 . At high radio frequencies the inherent plate-grid capacitance of the usual triode tube is sufficient for feed-back in the tuned-grid tuned-plate type circuit of *B*, so the feed-back condenser shown connected between grid and plate is not necessary.

There are many other arrangements of oscillator circuits but all utilize either inductive or capacitive feed-back. They will be treated in following chapters.

● DETECTION

Since the frequencies used in radio transmission are merely carriers bearing modulation, it is necessary to provide a means for making the signals intelligible. The process for doing this is called *detection* or *demodulation* — the latter because the modulation envelope is

Electrical and Radio Fundamentals

point. The grid attracts electrons from the cathode, the consequent grid current increasing more during the positive half cycles than it decreases during the negative half cycles of grid swing. Hence there is a rectified grid current flow at modulation frequency whose average value develops a voltage across the grid leak. This audio-frequency variation in voltage across the grid leak causes corresponding variations in plate current reproduced in the phones.

Regenerative Detectors

With both the grid and plate detectors just described it will be noted that a condenser is connected across the plate load circuit to bypass radio-frequency components in the output. This radio-frequency can be fed back into the grid circuit, as shown in *C* of Fig. 331, and re-amplified a number of times. This *regeneration* of the signal gives a tremendous increase in detector sensitivity. If the regeneration is sufficiently great the circuit will break into oscillation, which would be expected since the circuit arrangement is almost identical with that of the oscillator shown in Fig. 330-A. Therefore a control is necessary so that the detector can be operated either regenerating to give large amplification without oscillation, or to oscillate and regenerate simultaneously.

Oscillating Detectors

When a regenerative detector is made to oscillate by increasing the regeneration too far, the detector becomes useful in the reception of code or *c.w.* signals. Since a *c.w.* (continuous wave) signal is nothing more than a

carrier being rapidly switched on and off, there is no change in amplitude except at the instants of turning it on and off. Hence no

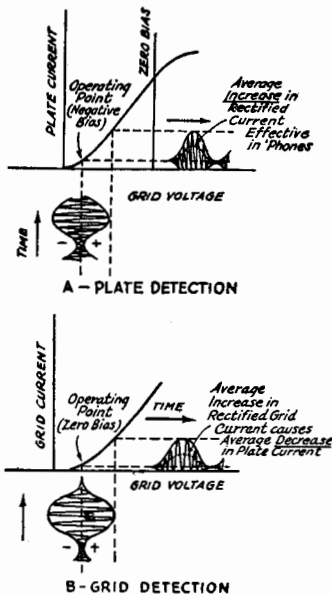

Fig. 332 — Operating characteristics of plate and grid detectors.

sound will be heard in the output of a normal detector fed by *c.w.* signals except at the beginning and end of each character. However, if a local oscillator is tuned 1000 cycles or so from the frequency of the signal, an audible beat note will be heard every time the signal comes through. The oscillating detector acts as both oscillator and detector, and the fact that the detector must be tuned 1000 cycles or so off-resonance from the signal does not materially reduce the signal voltage fed to the grid. For many years the standard method of *c.w.* reception was by means of an oscillating detector, but it has been superseded by the superheterodyne method of reception (treated later).

● SUPERREGENERATION

The limit to which regenerative amplification can be carried is the point at which the tube starts to oscillate, because when oscillations commence, further regenerative amplification ceases. To overcome this limitation and give still greater amplification, the *superregenerative* circuit has been devised. Essentially, the superregenerative detector is similar to the ordinary regenerative type but with a comparatively low-frequency super-audible (above audibility) signal introduced in such a way as to vary the detector's operating point. As a consequence of the introduction of this *quench*

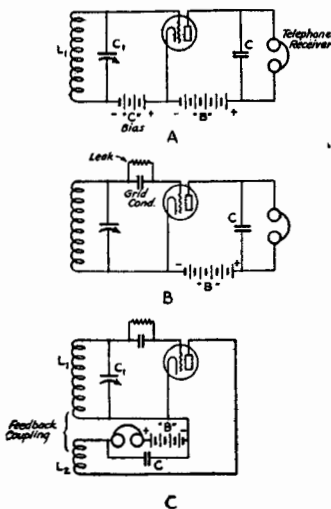

Fig. 331 — Detector circuits of three types. A, plate detection; B, grid detection; C, regenerative grid detection.

The Radio Amateur's Handbook

or *interruption frequency* the detector can oscillate at the signal frequency only when the moving operating point is in a region suitable for the production of oscillations. Because the oscillations are constantly being interrupted, the signal can build up to relatively tremendous proportions, and the superregen-

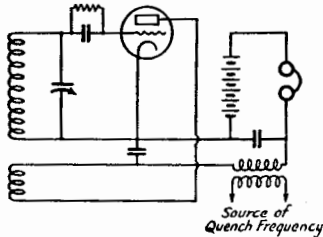

Fig. 333 — An elementary superregenerative circuit.

erative detector therefore is extremely sensitive. See Fig. 333. The circuit finds its chief field in the reception of ultra-high-frequency signals, for which purpose it has proved eminently successful.

● MULTI-ELEMENT TUBES

More than three elements may be used to make a tube particularly suitable for certain specialized applications; likewise two or more sets of elements may be combined in one bulb so that a single tube may be used to perform two or three separate functions.

Tubes having four elements are called *tetrodes*, while if a fifth element is added the tube is known as a *pentode*. Many element combinations and structures become possible as the number of electrodes is increased, but only a few have practical applications.

Tetrodes — Beam Tubes

In the section on tube oscillators it was explained that oscillations could be sustained through transfer of energy from the plate to the grid through the electrostatic capacity existing between plate and grid, the circuit of Fig. 330-B being used as an illustration. This circuit without the feed-back condenser is the one which would also be used if the tube is intended to amplify, but not oscillate, at radio frequencies; that is, the input and output circuits must be tuned to the same frequency. However, the grid-plate capacity of the triode returns so much energy to the grid circuit from the plate that it is impossible to prevent the tube from oscillating.

If a second grid, in the form of an electrostatic shield between the control grid and plate, is added, the grid-plate capacity can be reduced to a value which will not permit oscillations to occur. The *screen grid*, as it is called, increases the amplification factor and plate resistance of the tube to values much higher

than are attainable in triodes of practicable construction, although the mutual conductance is about the same as that of an equivalent triode. The screen grid is ordinarily operated at a positive potential about one-third that placed on the plate, and is by-passed back to the cathode so that it has essentially the same a.c. potential as the cathode.

Large screen-grid tubes of the power type are used as amplifiers in transmitting installations. The screen-grid tube can be used as both plate and grid detector, generally showing greater sensitivity than the triode types.

Another type of tetrode, in which the electrostatic shielding provided by the second grid is purely incidental, is built for audio power output work. The second grid (usually called the "screen" although not actually a screen grid) accelerates the flow of electrons from cathode to plate, and the structure gives a higher *power sensitivity* — ratio of power output to grid-voltage swing causing it — than is possible with triodes. "Beam" power tubes are tetrodes with special element structure so that the electrons are concentrated in desired paths to the plate. The beam principle results in relatively high plate efficiency and power sensitivity, with the effects of secondary emission overcome. Beam tubes are used both in audio amplifiers and radio-frequency transmitting circuits.

Pentodes

The addition of the screen grid in the ordinary tetrode causes an undesirable effect which limits the usefulness of the tube. Electrons striking the plate at high speeds dislodge other electrons which "splash" from the plate, causing secondary emission. In the triode, ordinarily operated with the grid negative with respect to cathode, these secondary electrons are repelled back into the plate and cause no disturbance. In the screen-grid tube, however, the positively charged screen grid attracts the secondary electrons, causing a reverse current to flow between screen and plate. The effect is particularly marked when the plate and screen potentials are nearly equal, which may be the case during part of the a.c. cycle when the instantaneous plate current is large.

To overcome the effects of secondary emission a third grid, called the *suppressor grid*, is inserted between the screen and plate. This grid, being connected directly to the cathode, repels the relatively low-velocity secondary electrons back to the plate without obstructing to any appreciable extent the regular plate-current flow. Larger undistorted outputs therefore can be secured from the pentode.

Pentode-type screen-grid tubes are used as radio-frequency voltage amplifiers, and in addition can be used as audio-frequency voltage

Electrical and Radio Fundamentals

amplifiers to give high voltage gain per stage. Pentode tubes also are suitable as audio-frequency power amplifiers, having greater plate efficiency than triodes and requiring less grid swing for maximum output.

Multi-Purpose Types

A great many types of tubes have been developed to do special work in receiving circuits. Among the simplest of these are full-wave rectifiers, combining two separate diodes of the power type in one bulb, and twin-triodes, consisting of two triodes in one bulb for Class-B audio amplification. To add the functions of diode detection and automatic volume control — described in Chapter Four on receivers — to that of amplification, a number of types are made in which two small diode plates are placed near the cathode, but not in the amplifier-portion structure. These types are known as duplex-diode triodes or duplex-diode pentodes, depending upon the type of amplifier.

The pentagrid converter is a special tube serving as both oscillator and mixer, used in superheterodyne receivers. There are five grids between cathode and plate in this tube; the two inner grids serve as control grid and plate of a small oscillator triode, while the fourth grid is the detector control grid. The third and fifth grids are connected together to form a screen-grid which shields the detector control grid electrostatically from the other elements. The pentagrid converter eliminates the need for special coupling between oscillator and detector circuits.

Another type consists of a triode and pentode in one bulb, for use where the oscillator and first detector are preferably separately coupled; while still another type (the 6L7) is a pentode with a separate grid for connection to an external oscillator circuit. This "injection" grid provides a means for introducing the oscillator voltage into the detector circuit by electronic means.

Receiving screen-grid tetrodes and pentodes for radio-frequency voltage amplification are made in two types, known as "sharp cut-off" and "variable- μ " or "super-control" types. In the sharp cut-off type the amplification

factor is practically constant regardless of grid bias, while in the variable- μ type the amplification factor decreases as the negative bias is increased. The purpose of this design is to permit the tube to handle large signal voltages without distortion in circuits in which grid-bias control is used to vary the amplification, and to reduce interference from stations on adjacent frequencies by preventing cross-modulation. Cross-modulation is modulation of the desired signal by an undesired one, and is practically the same thing as detection. The variable- μ type of tube is a poor detector in circuits used for r.f. amplification, hence cross-modulation is reduced by its use.

Types of Cathodes

Cathodes are of two types, directly and indirectly heated. Directly-heated cathodes or filaments used in receiving tubes are of the oxide-coated type, consisting of a wire or ribbon of tungsten coated with certain rare metals and earths which form an oxide capable of emitting large numbers of electrons with comparatively little cathode-heating power. Directly-heated cathodes are used in older audio power-output tubes, power rectifiers, tubes intended for operation from dry-cell batteries where economy of filament current is important, and in all but the smallest transmitting tubes.

When directly-heated cathodes are operated on alternating current, the cyclic variation of current causes electrostatic and magnetic effects which vary the plate current of the tube at supply-frequency rate and thus produce hum in the output. Hum from this source is eliminated by the indirectly-heated cathode, consisting of a thin metal sleeve or thimble, coated with electron-emitting material, enclosing a tungsten wire which acts as a heater. The heater brings the cathode thimble to the proper temperature to cause electron emission. This type of cathode is also known as the equipotential cathode, since all parts are at the same potential. The cathode ordinarily is not connected to the heater inside the tube, the terminals being brought out to separate base pins.

Reception of Radio Signals

Receiver Characteristics — Detectors — Amplifiers — The Superheterodyne — Single-Signal Reception

IN THIS chapter we shall discuss receivers designed for use on frequencies lying between 1750 and 30,000 kc. The general principles to be outlined are equally valid for the ultra-high-frequency region (above 30,000 kc.), but there are practical reasons why such receivers should be given separate treatment later in this volume.

The preceding chapter has explained the necessity for amplification and rectification ("detection") of the radio signals fed to the input terminals of the receiver by the antenna. A receiver has four important general characteristics: sensitivity, selectivity, stability, fidelity. To a considerable extent, the four are interlocking; that is, a change in one will affect the other three.

Sensitivity

Sensitivity is defined as the strength of the signal (usually expressed in microvolts) which must be applied to the input terminals of the receiver to produce a specified audio-frequency

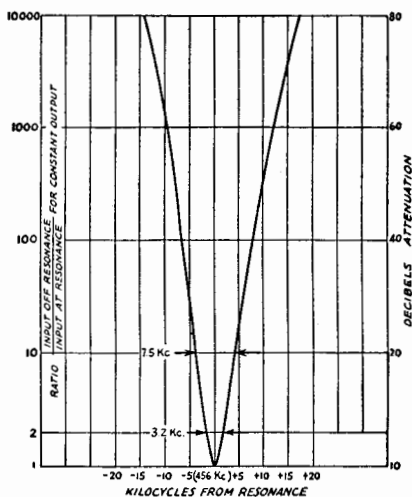

Fig. 401 — Selectivity curve of a modern superheterodyne receiver. The relative response is plotted against deviations above and below the resonance frequency. The scale at the left is in terms of voltage ratios; the corresponding decibel steps (see Chapter 20) are shown at the right.

power output at the loud-speaker or headset. This is a measure of the amplification or gain, but does not give a true representation of the ability of the receiver to make very weak signals intelligible. This property is dependent not only upon the amplification but also upon the presence of noise which, being amplified with the signal, may mask the latter.

Since noise, unlike the signal, does not have a definite frequency but is spread over a wide band of frequencies, the noise output will depend upon the width of the band of frequencies to which the receiver will respond. The noise output is consequently a function of the selectivity of the receiver.

Selectivity

Selectivity is the ability of a receiver to discriminate against signals of frequencies differing from that of the desired signal. The overall selectivity will depend upon the selectivity of the individual tuned circuits and the number of such circuits. It is also dependent upon the frequency characteristic of the audio amplifier in the receiver; the smaller the band of audio frequencies reproduced, the greater the contribution of the audio amplifier to selectivity.

The selectivity of a receiver is shown graphically by drawing a curve which gives the ratio of signal strength required at various frequencies off resonance, to the signal strength at resonance, to give constant output. A **resonance curve** of this type (taken on a typical communications-type superheterodyne receiver) is shown in Fig. 401. The **band-width** is the width of the resonance curve (in cycles or kilocycles) at a specified ratio; in Fig. 401, the band-widths are shown for ratios of 2 and 10.

Besides its importance in separating signals and its effect on noise (preceding section) selectivity also has an important effect on fidelity, and imposes requirements on stability.

Stability

Stability of a receiver is its ability to give constant output, over a period of time, from a signal of constant strength and frequency. Primarily, it means the ability to stay tuned to a given signal, although a receiver which at

Reception of Radio Signals

some settings of its controls has a tendency to break into oscillation, or "howl," is said to be unstable.

The stability of a receiver is affected principally by temperature variations, voltage changes, and constructional features of a mechanical nature.

Fidelity

Fidelity is the relative ability of the receiver to reproduce in its output the modulation (keying, 'phone, etc.) carried by the incoming signal. For exact reproduction, the band-width must be great enough to accommodate the highest modulation frequency, and the relative amplitudes of the various frequency components within the band must not be changed. In amateur work, a high order of fidelity is not required, even for 'phone reception; the important thing is to obtain adequate intelligibility. Considerably greater selectivity may be used on this basis, with a resulting decrease in interference. For keyed signals, the selectivity may be made extremely high without destroying the intelligibility.

DETECTORS

The simplest possible receiver would consist of a rectifier or detector associated with a tuned circuit for selecting a desired signal, along with a headset for making the rectified signals audible. The important characteristics of a detector are its sensitivity, fidelity or linearity, resistance, and signal-handling capability.

Detector **sensitivity** is the ratio of audio-frequency output to radio-frequency input. **Linearity** is a measure of the ability of the detector to reproduce, as an audio frequency, the exact form of the modulation on the incoming signal. The **resistance** of the detector is important in circuit design, since a relatively low resistance means that power is consumed in the detector. The **signal-handling capability** means the ability of the detector to accept signals of a specified amplitude without overloading.

The Diode

The simplest detector is the diode rectifier, the operation of which has been explained in Chapter 3. Circuits for both half-wave and full-wave diodes are given in Fig. 402. The simplified half-wave circuit at 402-A includes the r.f. **tuned circuit** L_2C_1 , with a **coupling coil** L_1 from which the r.f. energy is fed to L_2C_1 ; the diode, D , and the **load resistance** R_1 and **by-pass condenser** C_2 . The flow of rectified r.f. current through R_1 causes a d.c. voltage to develop across its terminals, and this voltage varies with the modulation on the signal. The - and + signs show the polarity of the voltage. Variation in amplitude

of the r.f. signal with modulation causes corresponding variations in the value of the d.c. voltage across R_1 . The load resistor, R_1 , usually has a rather high value so that a fairly large voltage will develop from a small rectified-current flow.

In the circuit at 402-B, R_1 and C_2 have been divided for the purpose of filtering r.f. from the output circuit; any r.f. voltage in the output may cause overloading of a succeeding amplifier tube. These audio-frequency variations can be transferred to another circuit through a **coupling condenser**, C_4 in Fig. 402, to a load resistor R_3 , which usually is a "potentiometer" so that the volume can be adjusted to a desired level.

The full-wave diode circuit at 402-C is practically identical in operation to the half-wave circuit, except that both halves of the r.f. cycle are utilized. The full-wave circuit has the advantage that very little r.f. voltage appears across the load resistor, R_1 , because the mid-point of L_2 is at the same potential as the cathode or "ground" for r.f.

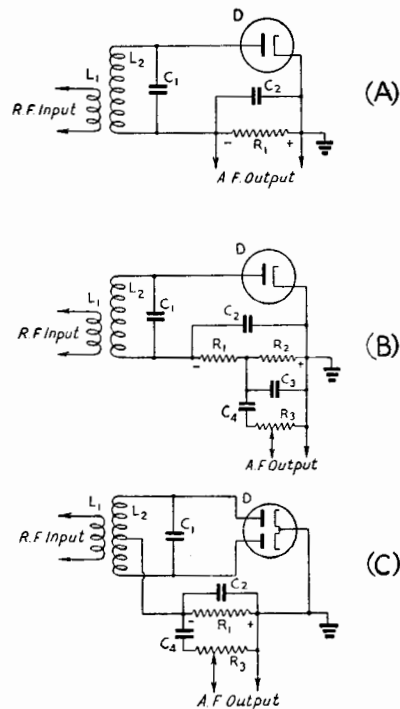

Fig. 402—Simplified and practical diode detector circuits. A, the elementary half-wave diode detector; B, a practical circuit, with r.f. filtering and audio output coupling; C, full-wave diode detector, with output coupling indicated. The circuit L_2C_1 is tuned to the signal frequency; typical values for C_2 and R_1 in A and C are 250 $\mu\text{fd.}$ and 250,000 ohms, respectively; in B, C_2 and C_3 are 100 $\mu\text{fd.}$ each; R_1 , 50,000 ohms; and R_2 , 250,000 ohms. C_4 is 0.1 $\mu\text{fd.}$ and R_3 , 0.5 to 1 megohm in all three diagrams.

The Radio Amateur's Handbook

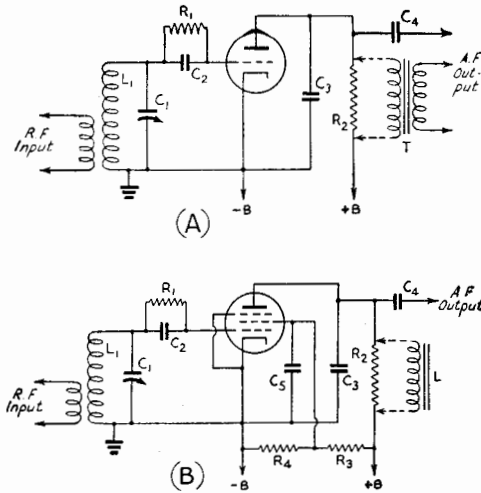

Fig. 403 — Grid-leak detector circuits. *A*, triode; *B*, pentode. A tetrode may be used in the circuit of *B* by neglecting the suppressor-grid connection. Transformer coupling may be substituted for resistance coupling in *A*, or a high-inductance choke may replace the plate resistor in *B*. L_1C_1 is a circuit tuned to the signal frequency. The grid leak, R_1 , may be connected directly from grid to cathode instead of across the grid condenser as shown. The operation with either connection will be the same. Representative values are:

Component	Circuit A	Circuit B
C_2	100 to 250 $\mu\text{fd.}$	100 to 250 $\mu\text{fd.}$
C_3	0.001 to 0.002 $\mu\text{fd.}$	250 to 500 $\mu\text{fd.}$
C_4	0.1 $\mu\text{fd.}$	0.1 $\mu\text{fd.}$
C_5		0.5 $\mu\text{fd.}$ or larger
R_1	1 to 2 megohms	1 to 5 megohms
R_2	50,000 ohms	100,000 to 250,000 ohms
R_3		50,000 ohms
R_4		20,000 ohms
<i>T</i>	Interstage audio transformer	
<i>L</i>		500-henry choke

The reactance of C_2 must be small compared to the resistance of R_1 at the radio frequency being rectified, but at audio frequencies must be relatively large compared to R_1 . This condition is satisfied by the values shown. If the capacity of C_2 is too large, the response at the higher audio frequencies will be low.

Compared with other detectors, the sensitivity of the diode is low. Since the diode consumes power, the Q of the tuned circuit is reduced, bringing about a reduction in selectivity. The linearity is good, however, and the signal-handling capability is high.

The Grid-Leak Detector

The grid-leak detector is a combination diode rectifier and audio-frequency amplifier. In the circuit of Fig. 403-A, the grid corresponds to the diode plate, and the rectifying action is exactly the same. The d.c. voltage from rectified current flow through the **grid leak**, R_1 biases the grid negatively with respect to cathode, and the audio-frequency

variations in voltage across R_1 are amplified through the tube just as in a normal a.f. amplifier. In the plate circuit, R_2 is the **plate load resistance** and C_3 a by-pass condenser to eliminate r.f. in the output circuit. C_4 is the **output coupling condenser**. With a triode, the load resistor R_2 may be replaced by an audio transformer, T , as shown, in which case C_4 is not used.

Since audio amplification is added to rectification, the grid-leak detector has considerably greater sensitivity than the plain diode. The sensitivity can be further increased by using a screen-grid tube instead of a triode, as at 403-B. The operation is equivalent to that of the triode circuit. C_5 , the **screen by-pass condenser**, should have low reactance for both radio and audio frequencies. R_3 and R_4 constitute a **voltage divider** from the plate supply to furnish the proper d.c. voltage to the screen. In both circuits, C_2 must have low r.f. reactance and high a.f. reactance compared to the resistance of R_1 ; the same consideration applies to C_3 with respect to R_2 .

The sensitivity of the grid-leak detector is higher than that of any other type, and it is therefore the preferred detector for weak sig-

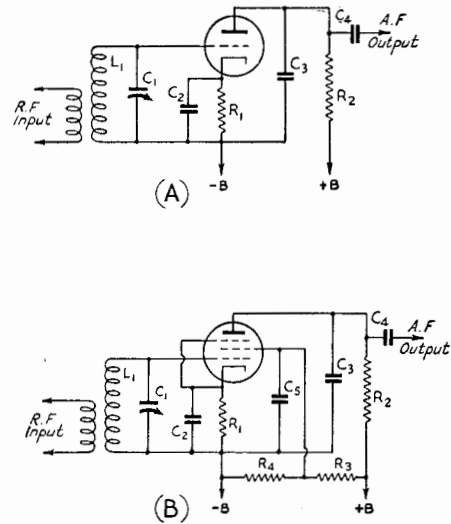

Fig. 404 — Circuits for plate detection. *A*, triode; *B*, pentode. L_1C_1 is tuned to the signal frequency. Typical values for other constants are:

Component	Circuit A	Circuit B
C_2	0.5 $\mu\text{fd.}$ or larger	0.5 $\mu\text{fd.}$ or larger
C_3	0.001 to 0.002 $\mu\text{fd.}$	250 to 500 $\mu\text{fd.}$
C_4	0.1 $\mu\text{fd.}$	0.1 $\mu\text{fd.}$
C_5		0.5 $\mu\text{fd.}$ or larger
R_1	10,000 to 20,000 ohms	10,000 to 20,000 ohms
R_2	50,000 to 100,000 ohms	100,000 to 250,000 ohms
R_3		50,000 ohms
R_4		20,000 ohms

Reception of Radio Signals

nals. Like the diode, it "loads" the tuned circuit and reduces its selectivity. The linearity is rather poor, and the signal-handling capability is limited.

The Plate Detector

The plate detector is a triode or screen-grid tube arranged so that rectification of the r.f. signal takes place in the plate circuit, as contrasted to the grid rectification just described. Sufficient negative bias is applied to the grid to bring the plate current nearly to the cut-off point, so that the application of a signal to the grid circuit causes an increase in average plate current. The average plate current follows the changes in signal amplitude in a fashion similar to the rectified current in a diode detector.

Circuits for triodes and pentodes are given in Fig. 404. C_3 is the plate by-pass condenser, R_1 is the cathode resistor which provides the operating grid bias, and C_2 is a by-pass, for both radio and audio frequencies, across R_1 . R_2 is the plate load resistance across which a voltage appears as a result of the rectifying action described above. It corresponds to the diode load resistance in Fig. 402. C_4 is the output coupling condenser. In the pentode circuit at B, R_3 and R_4 form a voltage divider to supply the proper potential (about 30 volts) to the screen, and C_5 is a by-pass condenser between the screen and cathode. C_6 must have low reactance for both radio and audio frequencies.

The plate detector is more sensitive than the diode, since there is some amplifying action in the tube, but less so than the grid-leak detector. It will handle considerably larger signals than the grid-leak detector, but is not quite as tolerant in this respect as the diode. Linearity, with the self-biased circuits shown, is good. Up to the overload point, the detector takes no power from the tuned circuit and hence does not affect its Q and selectivity.

Detection of Code (C.W.) Signals

In the detector circuits just described, audio-frequency output is secured only when the amplitude of the incoming signal is varied, or modulated, at an audio-frequency rate. In telegraph transmission, the characters of the telegraphic code are formed by turning on and off a signal, or carrier, of constant amplitude, and since at ordinary hand-sending speed this operation is not rapid enough to produce an audible tone, no sound is produced in a headset or loud-speaker. These detectors, therefore, are not suitable alone for the aural reception of c.w. telegraph signals.

The dots and dashes can be made audible by introducing into the detector a second radio frequency, differing by an audio frequency from the signal frequency, to beat with or heterodyne the incoming signal. The **beat-note**

is adjustable to any desired pitch by changing the "local" frequency with respect to the signal frequency. The "local" signal may be generated by an oscillator, the output of which is loosely coupled to the detector (**beat oscillator**), or by making the detector itself oscillate. The latter arrangement is called a **regenerative autodyne detector**.

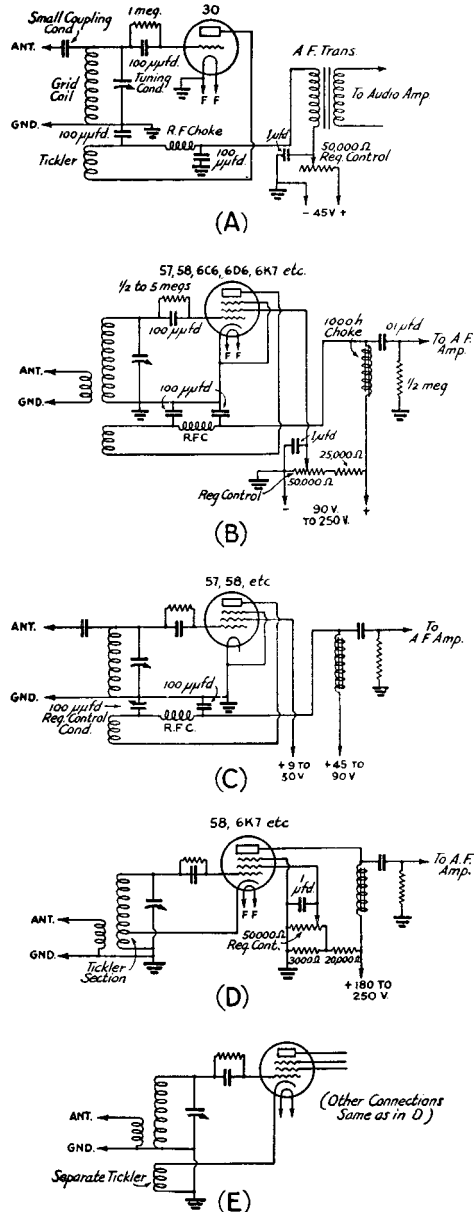

Fig. 405 — Triode and pentode (screen-grid) regenerative detector circuits.

The Radio Amateur's Handbook

Regenerative Detectors

The regenerative detector is enormously more sensitive to weak signals than the non-regenerative detectors previously described. Regeneration also increases the effective Q of the circuit and hence increases the selectivity, by virtue of the fact that the maximum regenerative amplification takes place at only the frequency to which the circuit is tuned. The grid-leak type of detector is most suitable for the purpose. Except for the regenerative connection, the circuit values are identical with those previously described for this type of detector, and the same considerations apply.

The sensitivity of the regenerative detector is greatest when the tube is oscillating very weakly, in beat-note reception, or when very near the oscillation point, but not actually oscillating, in reception of 'phone signals. A regeneration control must be provided so that the adjustment for greatest sensitivity can be obtained. Since there is a tendency, when the incoming signal is strong, for the oscillating detector to "pull" or "lock" into synchronism with the signal (when this happens, there is no difference between the two frequencies and the beat-note therefore disappears) the regeneration control setting will be different for signals of differing strengths. Also, the setting is quite critical, and in practical circuits it is difficult to get a system for regeneration control which does not also change the tuning of the circuit to some extent. Again, if the detector itself is coupled to an antenna, slight changes in the antenna constants (as when the wire swings in a breeze) affect the frequency of the oscillations generated by the detector, and thereby the beat frequency when c.w. signals are being received. The regeneration control setting also depends upon the coupling between the antenna and the detector circuit, an effect which varies with frequency.

Fig. 405 shows the circuits of regenerative detectors of various types. The circuit of *A* is for a triode tube, with an adjustable resistor in the d.c. plate feed to vary the plate voltage on the tube and thus to control regeneration. If both coils are wound end to end in the same direction, the plate connection is to the outside of the plate or "tickler" coil when the grid connection is to the outside of the tuned circuit.

The circuit of *B* is for a screen-grid tube, regeneration being controlled by adjustment of the screen-grid voltage. The tickler is in the plate circuit. As in the circuit of *A*, the portion of the control resistor between the rotating contact and ground is by-passed by a large condenser (0.5 μ f. or more) to filter out scratching noise when the arm is rotated. The

tickler should be adjusted so that the tube just goes into oscillation at a screen voltage of approximately 30 volts. The circuit of *C* is also for a screen-grid tube, but uses a variable by-pass condenser for regeneration control, the screen-grid voltage being fixed. When the capacity is small the tube does not regenerate, but as it increases toward maximum its reactance becomes smaller until a critical value is reached where there is sufficient feed-back to cause oscillation. This method of control is quiet and smooth in operation when the size of the tickler and coupling to the grid coil are carefully adjusted.

The circuit of *D* differs from that of *B* only in that the feed-back winding is in the cathode-to-ground circuit, being actually part of the tuned-circuit coil. This places it effectively in the plate circuit (plate to ground and thence to the cathode), so that the action is much the same. However, the tickler is also in the screen-to-cathode return circuit, and the screen operates to furnish feed-back as a sort of auxiliary plate. Hence a smaller tickler winding is required to give proper regeneration and oscillation. The circuit of *E* is the same as that of *D*, except that a separate feed-back winding is used. This eliminates the necessity of tapping the cathode into the main coil.

In all methods it is best that the tickler be mounted or wound at the "ground" end and not the grid end of the tuning coil. In the interests of smooth control it will be found advisable to use just as few turns on the tickler as will allow the tube to oscillate easily all over the tuning range.

● TUNED CIRCUITS — BAND CHANGING

The resonant circuits which are tuned to the frequency of the incoming signal constitute a special problem in the design of amateur receivers since, as explained in Chapter 2, the amateur frequency assignments consist of groups or bands of frequencies at widely-spaced intervals. The same LC combination cannot be used for, say, 14 Mc. and 3.5 Mc. It is necessary, therefore, to provide a means for changing the circuit constants for various frequency bands. As a matter of convenience, the same tuning condenser usually is retained, but new coils are inserted in the circuit for each band.

There are two favorite methods of changing inductances; one is to use a switch, having an appropriate number of contacts, which connects the desired coil and disconnects the others. The second is to use coils wound on forms with contacts (usually pins) which can be inserted in and removed from a socket. The switch is convenient in operation but, with the coil assembly, is bulky and somewhat difficult to adapt to home construction.

Reception of Radio Signals

Plug-in coils are preferred by the great majority of home builders because it is easier to work with them, and a compact circuit layout is readily possible.

Band-Spread Tuning

The tuning range of a given coil and variable condenser will depend upon the inductance of the coil and the change in tuning capacity. For ease of tuning it is desirable to adjust the tuning range so that practically the whole dial scale is occupied by the band in use. This is called **band-spreading**. Because of the varying widths of the bands, special tuning methods must be devised to give the correct maximum-minimum capacity ratio on each. Several of these are shown in Fig. 406.

In A, a small **band-spread condenser** C_1 (15 to 25 $\mu\text{fd.}$ maximum capacity) is used in parallel with a condenser, C_2 , which is usually large enough (140 to 175 $\mu\text{fd.}$) to cover a wide

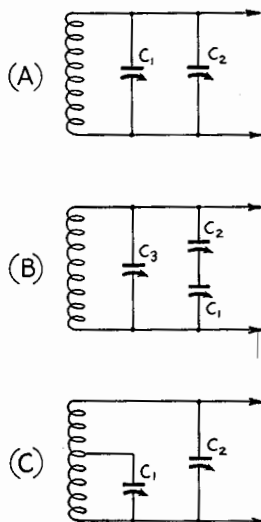

Fig. 406 — Essentials of band-spread tuning systems.

frequency range. The setting of C_2 will determine the minimum capacity of the circuit, and the maximum capacity for band-spread tuning will be the maximum capacity of C_1 plus the setting of C_2 . The inductance of the coil can be adjusted for each band so that the maximum-minimum ratio will give adequate band-spread. In practicable circuits it is almost impossible to get full band-spread on all bands with the same pair of condensers especially when, as is often the case, the coils are wound to give continuous frequency coverage on C_2 , which is variously called the **band-setting** or **main-tuning** condenser. Also, C_2 must be re-set each time the band is changed.

The method shown at B makes use of condensers in series. The tuning condenser, C_1 ,

may have a maximum capacity of 100 $\mu\text{fd.}$ or more. The minimum capacity is determined principally by the setting of C_3 , which usually is small, and the maximum capacity by the setting of C_2 , which is of the order of 25 to 50 $\mu\text{fd.}$ This method is capable of close adjustment to practically any desired degree of band-spread. C_2 and C_3 must be adjusted for each band or else separate pre-adjusted condensers must be switched in.

The circuit at C is probably the most popular with home constructors, since it gives complete spread on each band and requires a relatively small number of parts. C_1 , the band-spread condenser, may have any convenient value of capacity; 50 $\mu\text{fd.}$ is satisfactory. C_2 may be used for continuous frequency coverage ("general coverage") and as a band-setting condenser. The effective maximum-minimum capacity ratio depends upon the capacity of C_2 and the point at which C_1 is tapped on the coil. The nearer the tap to the bottom of the coil, the greater the band-spread, and vice versa. For a given coil and tap, the band-spread will be greater if C_2 is set at larger capacity. C_2 may be mounted in the plug-in coil form and pre-set, if desired. This requires a separate condenser for each band, but eliminates the necessity for re-setting C_2 each time the band is changed.

● AUDIO-FREQUENCY AMPLIFIERS

Audio-frequency amplifiers are used after the detector to increase the power to a level suitable for operating a loud-speaker or, in some cases, a headset. There are seldom more than two stages of a.f. amplification in a receiver, and often only one.

In all except battery-operated receivers, the negative grid bias of audio amplifiers is secured from the voltage drop in a cathode resistor. The cathode resistor must be by-passed by a condenser having low reactance, at the lowest audio frequency to be amplified, compared to the resistance of the cathode resistor (10% or less). In battery-operated sets, a separate grid-bias battery generally is used.

Headset and Voltage Amplifiers

The circuits shown in Fig. 407 are typical of those used for voltage amplification and for providing sufficient power for operation of headphones. Triodes usually are preferred to pentodes because they are better suited to working into an audio transformer or headset as a load.

In these circuits, R_2 is the **cathode bias resistor** and C_1 the **cathode by-pass condenser**. R_1 , the **grid resistor**, gives volume control action; the nearer the variable arm to the bottom of the resistor the smaller the voltage fed to the grid and hence the smaller the

The Radio Amateur's Handbook

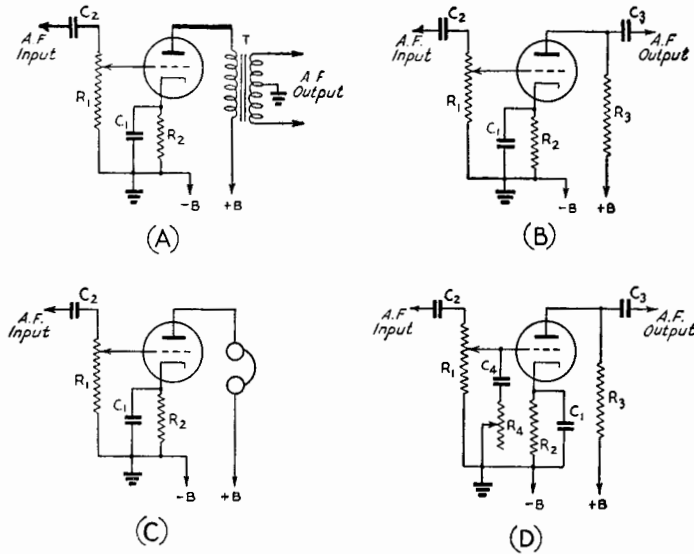

Fig. 407 — Audio amplifier circuits for voltage amplification and headphone output.

output. Its value ordinarily is from 0.25 to 1 megohm. C_2 is the **input coupling condenser**, already discussed under detectors; it is, in fact, identical to C_4 in Figs. 403 and 404 if the amplifier is coupled to a detector.

Tone Control

A tone control is a device for changing the frequency response of an audio amplifier; usually it is simply a method for reducing high-frequency response. This is helpful in reducing hissing and crackling noises without disturbing the intelligibility of the signal. R_4 and C_4 together in Fig. 407-D form an effective tone control of this type. The maximum effect is secured when R_4 is entirely out of the circuit, leaving C_4 connected between grid and ground. R_4 should be large enough so that when it is all in circuit the effect of C_4 on the frequency response is negligible.

Power Amplifiers

The most popular type of power amplifier in amateur receivers is the single pentode; the circuit diagram is given in Fig. 408-A. The grid resistor, R_1 , may be a potentiometer for volume control as shown at R_1 in Fig. 407. The **output transformer** T , should have a turns ratio suitable for the speaker used; most of the small speakers now available are furnished complete with output transformer.

When greater volume is needed a pair of pentodes or tetrodes may be connected in push-pull, as shown in Fig. 408-B. Transformer coupling to the voltage-amplifier stage is the simplest method of obtaining push-pull input for the amplifier grids. The **interstage transformer**, T_1 , has a center-tapped secondary,

with a secondary-to-primary **turns ratio** of about 2 to 1. An output transformer, T_2 , with a center-tapped primary must be used. No bypass condenser is needed across the cathode resistor, R , since the a.f. current does not flow through the resistor as it does in single-tube circuits.

● CATHODE CIRCUITS

In the discussion up to this point the cathode circuit details have not been shown completely, since they tend to complicate the diagrams. With indirectly-heated tubes it is customary to omit heater wiring, as in the dia-

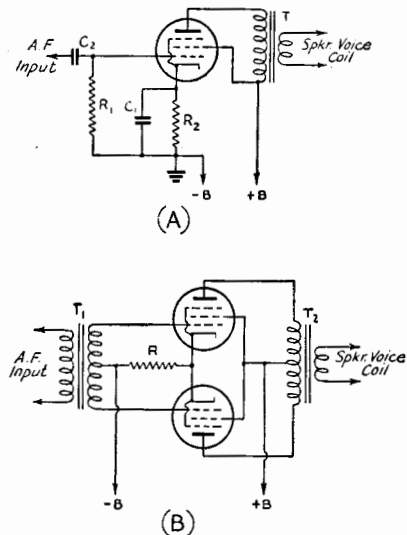

Fig. 408 — Audio power output amplifier circuits.

Reception of Radio Signals

grams at *A* and *D* in Fig. 409. With a.c. heater supply, the circuits at *B* and *E* are generally used; the heater wiring is twisted so that the magnetic fields about the wires cancel as fully as possible, which prevents a.c. hum from being induced in the other wiring. One side of the heater supply may be grounded, instead of the transformer center-tap; both methods give satisfactory results. A 6-volt storage battery may be substituted for the transformer for battery operation.

In *C* and *F* are shown circuits for filament-type tubes which are equivalent to the circuits for indirectly-heated tubes in the same rows. Note that in *F* a bias battery of the correct value is substituted for the cathode resistor used with the indirectly-heated tubes, since the cathode-drop method of biasing is not usually feasible with these tubes. The same "C" battery may be used for the entire receiver, provided it has taps at the voltages required for the various tubes used.

In all the circuits shown in this chapter, filament-type tubes may replace correspond-

Fig. 410 indicates, in "block" form, the type of receiver which for many years was the standard amateur set. It consists of a regenerative detector followed by an audio amplifier.

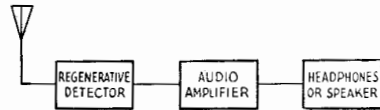

Fig. 410 — A simple type of receiver.

The latter may have either one or two stages, depending upon whether or not loud-speaker operation is desired. Any of the regenerative detector circuits already described may be combined with a voltage amplifier to form a two-tube set for headphone operation, and a power amplifier may be added for operating a speaker. A simple receiver of this type is quite effective and is easy and cheap to build but lacks the selectivity and stability so desirable in amateur operating. A typical example is given in Chapter 8.

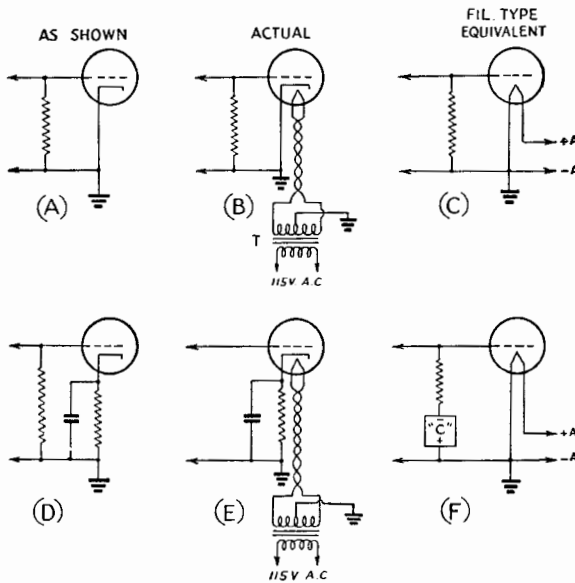

Fig. 409 — Cathode circuits as represented in circuit diagrams, and their equivalents.

ing types having indirectly-heated cathodes by substituting Fig. 409-C for *A*, and 409-F for *D*.

● SIMPLE RECEIVERS

In the circuits already described will be found the elements of a complete receiver. In fact, a detector alone will suffice, although an audio amplifier is a desirable addition since it increases the strength of the signals.

● RADIO-FREQUENCY AMPLIFIERS

Radio-frequency amplification is used to increase the strength of the signal and to provide selectivity before detection. Also, the **signal-to-noise ratio** is better than in the case of a detector, which is an important consideration in weak-signal reception.

R.F. Amplifier Circuits

Although there are variations in detail, practically all r.f. amplifiers conform to the basic circuit shown in Fig. 411. A screen-grid tube, usually a pentode, is invariably used, since a triode will oscillate when its grid and plate circuits are tuned to the same frequency. The amplifier operates Class A, without grid current. The **tuned grid circuit**, L_1C_1 , is coupled through L_2 to the antenna (or, in some cases, to a preceding stage). R_1 and C_2 are the **cathode bias resistor** and **cathode by-pass condenser**, C_3 the **screen by-pass condenser**, and R_2 the **screen dropping resistor**. L_3 is the primary of the **output transformer**, tightly coupled to L_4 which, with C_5 , constitutes the tuned circuit feeding the detector or a following amplifier tube. L_1C_1 and L_4C_5 are both tuned to the frequency of the incoming signal.

Shielding

The screen-grid construction prevents feedback from plate to grid inside the tube, but in addition it is necessary to prevent transfer of

The Radio Amateur's Handbook

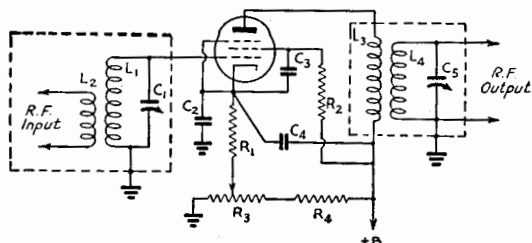

Fig. 411 — The circuit of a tuned radio-frequency amplifier. Circuit values are discussed in the text.

energy from the plate circuit to the grid circuit external to the tube. This is accomplished by enclosing the coils in shielding containers, and by keeping the plate and grid leads well separated. With "single-ended" tubes care in laying out the wiring to obtain the maximum possible physical separation between plate and grid leads is necessary to prevent capacity coupling.

The shield around a coil will reduce the Q of the coil to an extent which depends upon the shielding material and its distance from the coil. The resistance of the shield material should be low; copper is best, but aluminum is satisfactory if there is reasonable separation between the coil and shield. The shield should be at least a coil diameter away from the coil at the ends, and at least $\frac{1}{2}$ the coil diameter from the sides of the coil. The inductance of the coil is reduced somewhat by the presence of the shield; the closer the shield the greater the reduction. Adjustments to the inductance therefore must be made with the shield in place.

By-Passing

In addition to shielding, good by-passing is imperative. This is not simply a matter of choosing the proper type and capacity of by-pass condenser. Short *separate* leads from C_3 and C_4 to cathode or ground are a prime necessity, since at the higher radio frequencies even an inch or two of wire will have enough inductance to provide feedback coupling, and hence cause oscillation, if the wire happens to be common to both the plate and grid circuits.

Gain Control

The gain of an r.f. amplifier usually is varied by varying the grid bias. This method is applicable only to variable- μ type tubes, hence this type usually is found in r.f. amplifiers. In Fig. 411, R_3 and R_4 comprise the gain-control circuit. R_3 is the control resistor and R_4 a dropping resistor of such value as to make the voltage across the outside terminals of R_3 about 50 volts. The gain is maximum with the variable arm all the way to the left (grounded) on R_3 and minimum at the right. R_3 could simply be placed in series with R_1 , omitting R_4 entirely, but the range of control is limited when this connection is used.

In a multi-tube receiver, the gain on several stages would be varied simultaneously, a single control sufficing for all. In such a case, the lower ends of the several cathode resistors (R_1) would be connected together and to the movable contact on R_3 .

Circuit Values

The value of the cathode resistor, R_1 , should be calculated for the *minimum* recommended bias for the tube used. The capacities of C_2 , C_3 and C_4 must be such that the reactance is low at radio frequencies; this condition is easily met by using 0.01- μ fd. condensers. R_2 is found by taking the difference between the recommended plate and screen voltages, then substituting this and the rated screen current in Ohm's Law. R_3 must be selected on the basis of the number of tubes to be controlled; a resistor must be chosen which is capable of carrying, at its low-resistance end, the sum of all the tube currents plus the bleeder current. A resistor of suitable current-carrying capacity being found, the bleeder current necessary to produce a drop through it of about 50 volts can be calculated by Ohm's Law. The same formula will give R_4 , using the plate voltage less 50 volts for E and the bleeder current just found for I .

The constants of the tuned circuits will depend upon the frequency range, or band, being covered. A fairly high L/C ratio should be used on each band; this is limited, however, by the irreducible minimum capacities. An allowance of 10 to 20 $\mu\mu$ fd. must be made for tube and stray capacity (the input and output capacities of r.f. tubes are given in the tube tables); the minimum capacity of the tuning condenser also must be added.

If the input circuit of the amplifier is connected to an antenna, the coupling coil L_2 should be adjusted to provide an impedance match between the antenna and grid circuit. This will give maximum energy transfer. The turns ratio L_1/L_2 will depend upon the frequency, the type of tube used, the Q of the tuned circuit, and the antenna system, and in general is best determined experimentally. The selectivity will increase as the coupling is reduced below this "optimum" value, a consideration which it is well to keep in mind if

Reception of Radio Signals

selectivity is of more importance than maximum gain.

The output circuit coupling depends upon the output resistance of the tube, the input resistance of the succeeding stage, and the Q of the tuned circuit L_4C_5 . L_3 is usually coupled as closely as possible to L_4 (this avoids the necessity for an additional tuning condenser across L_3) and the energy transfer is about maximum when L_3 has $\frac{3}{2}$ to $\frac{1}{2}$ as many turns as L_4 , with ordinary receiving screen-grid pentodes.

Ganged Tuning

The tuning condensers of the several r.f. circuits may be coupled together mechanically and operated by a single control. This operating convenience involves more complicated construction, both electrically and mechanically. It becomes necessary to make the various circuits **track** — that is, at each setting of the tuning control all circuits must tune to the same frequency.

True tracking can be obtained only when the inductance, minimum capacity and maximum capacity are identical in all "ganged" stages. This can be done by using identical tuning condensers and matching the coil inductances. A small **trimmer** or **padding** condenser is connected across the coil so that variations in minimum capacity can be compensated. The fundamental circuit is shown in Fig. 412, where C_1 is the trimmer and C_2 the tuning condenser. The use of the trimmer further increases the minimum circuit capacity, but is a necessity for satisfactory tracking. Condensers having maximum capacities of 15 to 25 μfd . generally are used for the purpose.

The same methods are applied to band-spread circuits which must be tracked. The circuits are identical with those of Fig. 406, although if both general-coverage and band-spread tuning are to be available, an additional trimmer condenser must be connected across the coil in each circuit shown. If only amateur-band tuning is desired, however, then C_3 in Fig. 406-B, and C_2 in Fig. 406-C serve as trimmers. Fig. 406-A is not particularly recommended for purely amateur-band receivers.

The coil inductance can be adjusted by starting with a larger number of turns than necessary, then removing a turn or fraction of a turn at a time until the circuits track satisfactorily. An alternative method of adjusting

Fig. 412 — Showing the use of a trimmer condenser across the tuned circuit to set the minimum circuit capacity for ganged tuning.

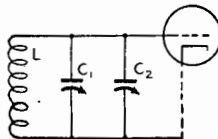

inductance, providing it is reasonably close to the correct value initially, is to make the coil so that the last turn is variable with respect to the whole coil, or to use a single short-circuited turn the position of which can be varied with respect to the coil. These methods are shown in Fig. 413.

Tube and Circuit Noise

In any conductor electrons will be moving in random directions simultaneously and, as a result, small irregular voltages are developed across the conductor terminals. The voltage is larger the greater the resistance of the conductor and the higher its temperature. This is known as the **thermal agitation effect**, and

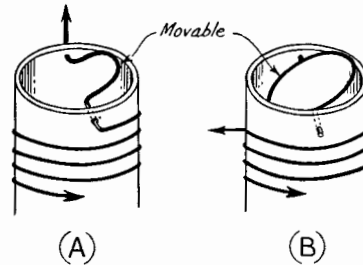

Fig. 413 — Methods of adjusting inductance for ganging. The half turn in *A* can be moved so that its magnetic field either aids or opposes the field of the coil. The shorted loop in *B* is not connected to the coil, but operates by induction. It will have no effect on the coil inductance when the plane of the loop is parallel to the axis of the coil, and will give maximum reduction of the coil inductance when perpendicular to the coil axis.

it produces a hiss-like noise voltage distributed uniformly throughout the radio-frequency spectrum. The thermal agitation noise voltage appearing across the terminals of a tuned circuit will be the same as in a resistor of a value equal to the impedance of the tuned circuit, even though the actual circuit resistance is low. Hence the higher the Q of the circuit the greater the thermal agitation noise.

Another component of hiss noise is developed in the tube, because the rain of electrons on the plate is not entirely uniform. Small irregularities caused by gas in the tube also contribute to the effect. Tube noise varies with the type of tube, and is proportional in a general way to the inverse ratio of the mutual conductance of the tube to the square root of the plate current.

To obtain the best signal-to-noise ratio, the signal must be made as large as possible at the grid of the tube, which means that the antenna coupling must be adjusted to that end, and also that the Q of the grid tuned circuit must be high. A tube with low inherent noise obviously should be chosen. In an amplifier having good signal-to-noise ratio the thermal agita-

The Radio Amateur's Handbook

tion noise will be greater than the tube noise. This can easily be checked by grounding the grid through a 0.01- μ fd. condenser and observing whether there is a decrease in noise. If there is no change, the tube noise is greatly predominant, indicating a poor signal-to-noise ratio in the stage. The test is valid only if there is no regeneration in the amplifier. The signal-to-noise ratio will decrease as the frequency is raised because it becomes increasingly difficult to obtain a high- Q tuned circuit.

The first stage of the receiver is the important one from the signal-to-noise ratio standpoint. Noise generated in the second and subsequent stages, while comparable in magnitude to that generated in the first, is masked by the amplified noise and signal from the first stage. After the second stage, further contributions by tubes and circuits to the total noise are inconsequential in any normal receiver.

Circuit Loading.

At high frequencies the tube may consume power from the tuned grid circuit even though the grid is not driven positive by the signal. Above 7 Mc. all tubes load the tuned circuit to an extent which depends upon the type of tube. This effect comes about because the time necessary for electrons to travel from the cathode to the grid becomes comparable to the time of one r.f. cycle, and because of an inductive effect of the cathode lead. The tube input circuit resistance may be as low as a few thousand ohms at 28 Mc., with certain tubes.

This **input loading** effect is in addition to the normal decrease in the Q of the circuit alone at the higher frequencies because of increased losses in the coil and condenser. Thus the selectivity and gain of the circuit are both adversely affected.

Comparison of Tubes for the R.F. Amplifier

At 7 Mc. and lower frequencies, the signal-to-noise ratio, gain and selectivity of an r.f. amplifier stage are sufficiently high with any of the standard receiving tubes. At 14 Mc. and higher, however, this is no longer true, and the choice of a tube must be based on several conflicting considerations.

Gain is highest with high mutual-conductance pentodes, the 1851 and 1852 being examples of this type. These tubes also develop less noise than any of the others. The input-

loading effect is greatest with them, however, so that selectivity is decreased and the tuned-circuit gain is lowered.

Pentodes such as the 6K7, 6J7 and corresponding types in glass have lesser input-loading effects at high frequencies, moderate gain, and relatively-high inherent noise.

The "acorn" pentodes, 954 and 956, are excellent from the input-loading standpoint, the gain is about the same as with the standard types, and the inherent noise is somewhat lower. They are rather difficult to handle mechanically, however, and are not as rugged electrically as the larger tubes.

Where selectivity is paramount, the acorns are best, standard pentodes second, and the 1851-52 types last. On signal-to-noise ratio the 1851-52 tubes are first, acorns second, and standard pentodes third. The same order holds for overall gain.

Receivers with R.F. Amplification

A stage of radio-frequency amplification may be added to a receiver having a regenerative detector to form what is popularly called a **tuned r.f.** receiver. It is shown in block diagram form in Fig. 414. The amplifier circuit of Fig. 411 is installed ahead of any of the detector circuits of Fig. 405, with L_4C_5 in Fig. 411 becoming the tuned grid circuit of the detector. The methods of ganging and band-spreading already described may be applied to the tuned circuits.

Although antenna loading effects are overcome by using an r.f. amplifier stage before the regenerative detector, the other disadvantages of this type of detector remain. The added selectivity of the r.f. stage is not of much help except in partially tuning out strong local signals on frequencies considerably different from that of the desired signal. The r.f. stage increases the tendency of the detector to block, since blocking is worse the greater the signal strength. The selectivity becomes increasingly poorer as the frequency is raised, and is not high enough even at the lower frequencies to meet present-day conditions. For these reasons, plus the fact that greater overall gain is obtainable, regenerative receivers have largely been superseded by the superheterodyne receiver.

● THE SUPERHETERODYNE

In the superheterodyne, or superhet, receiver the frequency of the incoming signal is

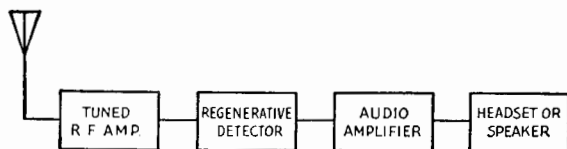

Fig. 414—Block diagram of a receiver with tuned radio-frequency amplification preceding a regenerative detector and audio amplifier.

Reception of Radio Signals

changed to a new radio frequency, the **intermediate frequency (i.f.)**, then amplified, and finally detected. The frequency is changed by means of the heterodyne process, the output of an adjustable **local oscillator (h.f. oscillator)** being combined with the incoming signal in a **mixer or converter stage (first detector)** to produce a beat frequency equal to the i.f. Fig. 415 gives the essentials of the superhet in block form. The process of detection and audio amplification is similar to that already described. C.w. signals are made audible by heterodyning the signal at the second detector by an oscillator (the **beat oscillator**) set to differ from the i.f. by a suitable audio frequency.

A numerical example will help make the operation of the receiver clearer. Assume that an intermediate frequency of 455 kc. is chosen, and that the incoming signal is on 7000 kc. Then the h.f. oscillator frequency may be set to 7455 kc. in order that the beat frequency (7455 minus 7000) will be 455 kc. The h.f. oscillator also could be set to 6545 kc., which will give the same frequency difference. To produce an audible c.w. signal of say 1000 cycles at the second detector, the beat oscillator would be set either to 454 kc. or 456 kc.

The frequency-conversion process permits r.f. amplification at a relatively-low frequency where high selectivity can be obtained, and this selectivity is constant regardless of the signal frequency. Higher gain is also possible at the low frequencies used for intermediate amplification. The separate oscillators can be designed for stability, and since the h.f. oscillator is working at a frequency considerably removed from the signal frequency its stability is practically unaffected by the strength of the incoming signal.

Images

Each h.f. oscillator frequency will cause i.f. response at two signal frequencies, one higher and one lower than the oscillator frequency. If the oscillator is set to 7455 kc. to respond to a 7000-kc. signal, for example, it will also respond to a signal on 7910 kc., which likewise gives a 455-kc. beat. The undesired signal of the two is called the **image**. When the r.f. circuit is tuned to the desired signal frequency,

and desired-signal and image voltages of equal magnitude are alternately applied to the circuit, the ratio of desired-signal to image i.f. output is called the **signal-to-image ratio**, or **image ratio** for short.

The image ratio depends upon the selectivity of the r.f. circuits preceding the mixer. Also, the higher the intermediate frequency the higher the image ratio, since raising the i.f. increases the frequency separation between signal and image and thus places the latter farther away from the peak of the resonance curve of the signal-frequency circuits.

● FREQUENCY CONVERSION

The first detector or mixer resembles an ordinary detector of the types already described. A circuit tuned to the intermediate frequency is placed in the plate circuit of the mixer so that the highest possible i.f. voltage will be developed. The signal- and oscillator-frequency voltages appearing in the plate circuit are bypassed to ground since they are not wanted in the output. The i.f. tuned circuit should have low impedance for these frequencies, a condition easily met if they do not approach the intermediate-frequency.

The important characteristics of a mixer are its **conversion efficiency**, and **pulling** effect on the oscillator frequency. The efficiency of the mixer is measured by the ratio of i.f. output voltage from the plate circuit to r.f. signal voltage applied to the grid. High conversion efficiency is obviously desirable. The mixer tube noise also should be low if a good signal-to-noise ratio is wanted, particularly if the mixer is the first tube in the receiver.

The mixer should not require too much r.f. power from the h.f. oscillator, since it may be difficult to supply the power and maintain good oscillator stability, especially at the higher frequencies (14 and 28 Mc.). Also, the conversion efficiency should not depend too critically on the oscillator voltage (that is, a small change in oscillator output should not change the gain appreciably) since it is difficult to maintain constant oscillator output over a wide frequency range.

Pulling is a change in oscillator frequency caused by tuning of the mixer grid circuit. If the two circuits could be completely isolated,

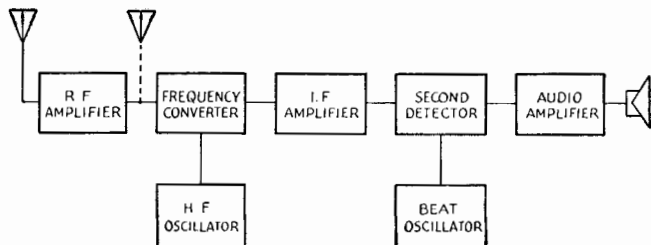

Fig. 415 — The basic superheterodyne arrangement.

The Radio Amateur's Handbook

mixer tuning would have no effect on the oscillator frequency, but in practice this is a difficult condition to attain. Pulling is a source of oscillator instability and should be minimized, because the stability of the whole receiver depends critically upon the stability of the h.f. oscillator. The pulling effect decreases with the separation between the signal and h.f. oscillator frequencies, hence is less with high intermediate frequencies and greater with low i.f.'s.

Mixing Methods

Typical frequency-conversion circuits are given in Fig. 416. The variations are chiefly in the way in which the oscillator voltage is introduced, and other methods than those shown are possible. In 416-A, the screen-grid tube functions as a plate detector; the oscillator voltage is capacity-coupled to the grid of the tube in parallel with the tuned input circuit. Inductive coupling may be used instead. The conversion gain and input selectivity are generally good so long as the sum of the two voltages (r.f. and oscillator) impressed on the grid does not exceed the grid bias. It is desirable to make the oscillator voltage as high as possible without exceeding this limitation. The oscillator voltage required is small and the power negligible.

A pentagrid-converter tube is used in the

circuit at *B*. Although intended for combination oscillator-mixer use, this type of tube usually will give more satisfactory performance when used in conjunction with a separate oscillator, the output of which is coupled in as shown. The circuit gives good conversion efficiency, and because of the electron coupling gives desirable isolation between the mixer and oscillator circuits. A small amount of power is required from the oscillator.

In circuit *C*, using the 6L7 mixer tube, the value of oscillator voltage can vary over a considerable range without affecting the conversion gain. There are no critical adjustments and the oscillator-mixer isolation is good. The oscillator must supply somewhat more power than in *B*.

A more stable receiver generally results, particularly at the higher frequencies, when separate tubes are used for the mixer and oscillator. The same number of circuit components is required whether or not a combination tube is used, so that there is little difference from the cost standpoint.

Tubes for Frequency Conversion

For Fig. 416-A a sharp cut-off pentode is preferred. The 1851 or 1852 give very high conversion gain and an excellent signal-to-noise ratio — comparable, in fact, to the gain and signal-to-noise ratio obtainable with r.f. amplifiers, and in these respects far superior to any other tubes used as mixers. This type of tube loads the circuit more, however, and thus decreases the selectivity.

The 6K8 is a good tube for the circuit at *B*; its oscillator plate connection may be ignored. The 6SA7 is excellent in this circuit, although its grid arrangement differs slightly from that shown. The 6K8 is the best tube for use as a combination mixer-oscillator.

The 6L7 is the only tube of its type, and hence the only one suitable for circuit *C*.

● THE HIGH-FREQUENCY OSCILLATOR

Stability of the receiver is chiefly dependent upon the stability of the h.f. oscillator, and particular care should be given this part of the receiver. The frequency of oscillation should be insensitive to changes in voltage, loading, and mechanical shock. Thermal effects (slow change in frequency because of tube or circuit heating) should be minimized. These ends can be attained by the use of good insulating materials and good-quality circuit components, by suitable electrical design, and by careful mechanical construction.

In addition, the oscillator must be capable of furnishing sufficient r.f. voltage and power to the particular mixer circuit chosen, at all frequencies within the range of the receiver, and its harmonic output should be as low as pos-

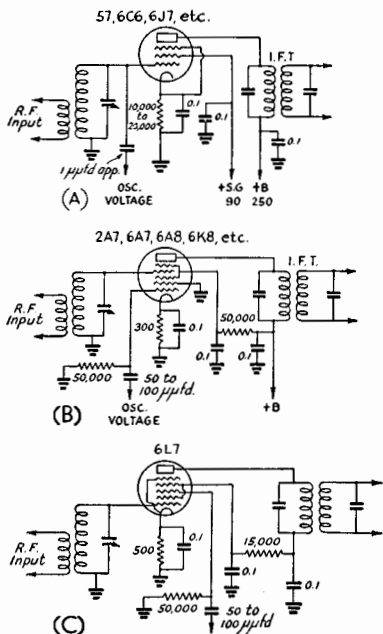

Fig. 416 — Mixer or Converter Circuits. *A*, grid injection; *B* and *C*, separate injection circuits for converter tubes. If an 1851 or 1852 is used in circuit *A*, the cathode resistor should be changed from 300 to 500 ohms.

Reception of Radio Signals

sible. When harmonics are present, they may mix with incoming signals of frequencies far removed from the desired frequency, to produce spurious signals at intermediate frequency.

Design Considerations

No matter what the circuit chosen, it is desirable to make the L/C ratio in the oscillator tuned circuit as low as possible (high- C) since this results in increased stability in almost every respect. It is not hard to do this in amateur-band receivers, since there is considerably greater freedom in design than in the case of receivers intended for continuous coverage.

Particular care should be taken to insure that no part of the oscillator circuit will vibrate mechanically. This calls for short leads and very "solid" mechanical construction. The chassis and panel material should be heavy and rigid enough so that pressure on the tuning dial will not cause torsion and a shift in the frequency. Care in mechanical construction is well repaid by increased frequency stability.

Oscillator Circuits

Several oscillator circuits are shown in Fig. 417. The point at which output voltage is taken for the mixer is indicated by the "X" or "Y" in each case. *A* and *B* will give about the same results, and require only one coil. However, in these two circuits the cathode is above ground potential for r.f., which often is a cause of hum modulation of the oscillator output at 14 and 28 Mc. when 6.3-volt heater tubes are used. Hum is usually not bothersome with 2.5-volt tubes, nor, of course, with tubes which are heated by direct current. The equivalent circuits for filament-type tubes can easily be drawn with the help of Fig. 409. The circuit of 417-C overcomes hum with 6.3-volt tubes, but requires two coils. This is advantageous in construction, however, because it makes the feedback adjustment simpler mechanically.

Besides the use of a fairly high C/L ratio in the tuned circuit, it is necessary to adjust the feedback to obtain optimum results. Too much feedback will cause the oscillator to "squeg," or operate at several frequencies simultaneously; too little feedback will cause the output to be low. In the tapped-coil circuits (*A*, *B*) the feedback is increased by moving the tap toward the grid end of the coil; in *C*, by increasing the number of turns on L_2 or by moving L_2 closer to L_1 .

The oscillator plate voltage should be as low as is consistent with adequate output. Low plate voltage will reduce tube heating and thereby reduce frequency drift. In all circuits

Fig. 417 — High-frequency oscillator circuits. *A*, screen-grid grounded-plate oscillator; *B*, triode grounded-plate oscillator; *C*, triode, tickler circuit. Coupling to mixer may be taken from points X and Y. In *A* and *B*, coupling from Y will reduce pulling effects, but gives less voltage than from X; it is therefore best adapted to those mixer circuits with small oscillator-voltage requirements.

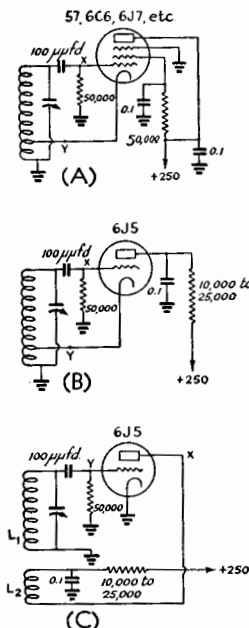

it is essential that the oscillator be shielded from the mixer. Coupling other than by the means intended, especially between the tuned circuits, will result in pulling.

Tracking

For ganged tuning, the oscillator tuning must track with the mixer tuning. In this case the problem is to maintain a *constant difference* in frequency (i.f.) between the two circuits.

Tracking methods for covering a wide frequency range, suitable for general-coverage receivers, are shown in Fig. 418. The tracking capacity C_5 commonly consists of two condensers in parallel, a fixed one of somewhat less capacity than the value needed and a smaller variable in parallel to allow for adjustment to the exact proper value. In practice, the trimmer C_4 is first set for the high-frequency end of the tuning range and then the tracking condenser is set for the low-frequency end. The tracking capacity becomes larger as the ratio of the oscillator to signal frequency becomes nearer to unity (that is, as the tuning frequency becomes higher). Typical circuit values are given in the accompanying table.

In amateur-band receivers tracking is simplified by choosing a band-spread circuit which gives practically straight-line-frequency tuning (equal frequency change for each dial division) and then adjusting the two circuits so that both cover the same total number of kilocycles. For example, if the i.f. is 455 kc. and

The Radio Amateur's Handbook

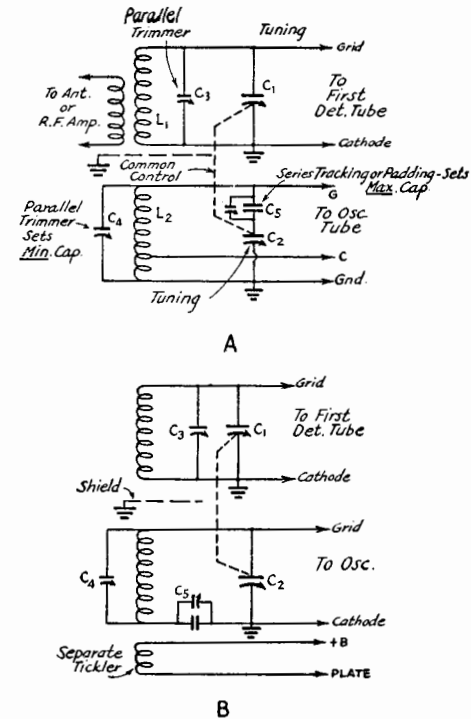

Fig. 418 — Converter circuit tracking methods. Approximate circuit values for 450- to 465-kc. intermediates with tuning ranges of approximately 2.15-to-1. C_1 and C_2 having a maximum of 140 $\mu\text{fd.}$ and the total minimum capacitance, including C_3 or C_4 , being 30 to 35 $\mu\text{fd.}$

Tuning Range	L_1	L_2	C_5
1.7-4 Mc.	50 $\mu\text{h.}$	40 $\mu\text{h.}$	0.0013 $\mu\text{fd.}$
3.7-7.5 Mc.	14 $\mu\text{h.}$	12.2 $\mu\text{h.}$	0.0022 $\mu\text{fd.}$
7-15 Mc.	3.5 $\mu\text{h.}$	3 $\mu\text{h.}$	0.0045 $\mu\text{fd.}$
14-30 Mc.	0.8 $\mu\text{h.}$	0.78 $\mu\text{h.}$	None used

Approximate values for 450- to 465-kc. i.f. with a 2.5-to-1 tuning range, C_1 and C_2 being 350- $\mu\text{fd.}$ maximum, minimum capacitance including C_3 and C_4 being 40 to 50 $\mu\text{fd.}$

Tuning Range	L_1	L_3	C_5
0.5-1.5 Mc.	240 $\mu\text{h.}$	130 $\mu\text{h.}$	425 $\mu\text{fd.}$
1.5-4 Mc.	32 $\mu\text{h.}$	25 $\mu\text{h.}$	0.00115 $\mu\text{fd.}$
4-10 Mc.	4.5 $\mu\text{h.}$	4 $\mu\text{h.}$	0.0028 $\mu\text{fd.}$
10-25 Mc.	0.8 $\mu\text{h.}$	0.75 $\mu\text{h.}$	None used

the mixer circuit tunes from 7000 to 7300 kc. between two given points on the dial, then the oscillator must tune from 7455 to 7755 kc. between the same two dial readings. With the band-spread arrangement of Fig. 406-C the tuning will be practically straight-line fre-

quency; the same is true of 406-A if C_1 is small compared to C_2 .

● INTERMEDIATE-FREQUENCY AMPLIFIER

The selection of an intermediate frequency is a compromise between various conflicting factors. The lower the i.f., the higher the selectivity and gain, but a low i.f. brings the image nearer the desired signal and hence decreases the image ratio. A low i.f. also increases pulling of the oscillator frequency. On the other hand, a high i.f. is beneficial to both image ratio and pulling, but the selectivity and gain are lowered. The difference in gain is least important.

An i.f. of the order of 455 kc. gives good selectivity and is satisfactory from the standpoint of image ratio and oscillator pulling at frequencies up to 7 Mc. The image ratio is poor at 14 Mc. when the mixer is connected to the antenna, but adequate when there is a tuned r.f. amplifier between antenna and mixer. At 28 Mc., the image ratio is very poor unless several r.f. stages are used. At both 14 and 28 Mc. pulling is likely to be bad unless very loose coupling can be used between mixer and oscillator.

By going to an i.f. of about 1600 kc., satisfactory image ratios can be secured on 14 and 28 Mc., and pulling can be reduced to negligible proportions. However, the i.f. selectivity is considerably lower, so that more tuned circuits must be used to increase the selectivity.

In choosing an i.f. it is wise to avoid frequencies on which there is considerable activity by the various radio services, since such signals may be picked up directly on the i.f. wiring. The two frequencies mentioned are fairly free of such interference.

I.F. Transformers

The tuned circuits of i.f. amplifiers are built up as transformers, consisting of a shielding container in which the coils and condensers are mounted. Both air-core and powdered-iron-core universal-wound coils are used, the latter having somewhat higher Q 's and, hence, greater selectivity and gain per unit.

Variable tuning condensers are of the midget type, air-dielectric condensers being preferable because their capacity is practically unaffected by changes in temperature. Iron-core transformers may be tuned by varying the inductance (permeability tuning) in which case stability comparable to that of variable air-condenser tuning can be obtained by use of high-stability fixed mica condensers. Such stability is of great importance in highly selective i.f. amplifiers.

Intermediate-frequency amplifiers usually consist of one or two stages. With modern tubes and transformers, two stages at 455

Reception of Radio Signals

ko. will give all the gain usable, considering the noise level. If regeneration is introduced into the i.f. amplifier a single stage will give enough gain for all practical purposes.

Typical circuit arrangements for three types of transformers are shown in Fig. 419. Alternative methods of gain-control biasing, by-passing and decoupling are indicated. The method of returning all by-passes to the cathode shown in C is recommended. Where two such stages are used there will be a tendency to instability and oscillation because of the high gain, and careful circuit arrangement is necessary.

Tubes for I.F. Amplifiers

Variable- μ pentodes are almost invariably used in i.f. amplifier stages, since grid-bias gain control is practically always applied to the i.f. amplifier. Tubes with high plate resistance will have least effect on the selectivity of the amplifier, and those with high mutual conductance will give greatest gain. The choice of i.f. tubes will have practically no effect on the signal-to-noise ratio, since this will have been determined by the preceding mixer and r.f. amplifier (if used).

If single-ended tubes are used, care should be taken to keep the plate and grid leads well separated. With these tubes it is advisable to mount the screen by-pass condenser directly across the socket between the plate and grid pins to provide additional shielding, making sure that the outside foil of the condenser is connected to ground.

The Second Detector

The second detector of a superhet receiver performs the same function as the detector in the simple receiver, but usually operates at a higher input level because of the relatively great r.f. amplification. Therefore, the ability to handle large signals without distortion is preferable to high sensitivity. Plate detection is used to some extent, but the diode detector is the most popular. It is especially adapted to furnishing automatic gain or automatic volume control (a.v.c.), which gives it an additional advantage. A wide variety of combinations will be found, including circuits using multi-element tubes which include diode elements, but all are basically the same.

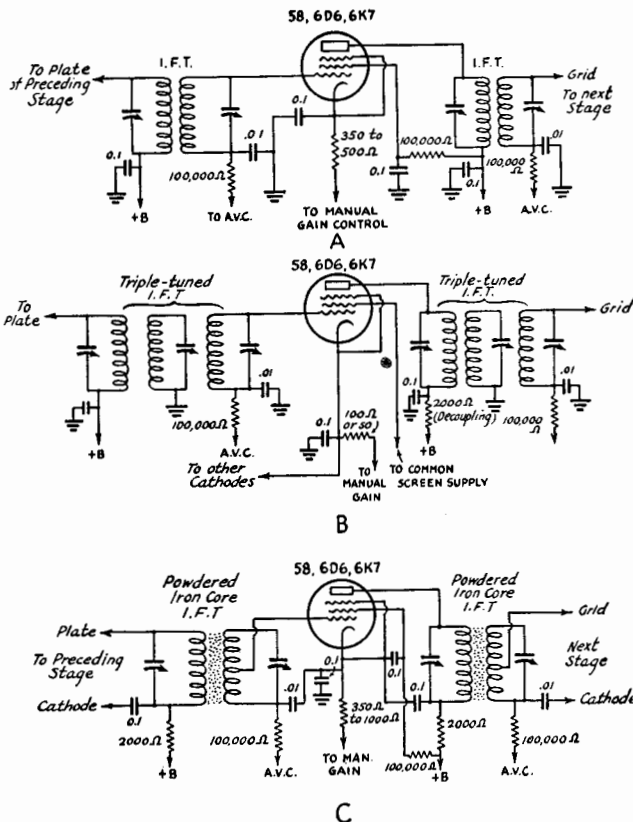

Fig. 419 — I.F. amplifier circuits for three types of transformers. A, double-tuned; B, triple-tuned; C, high-gain iron core.

The Beat Oscillator

Any standard oscillator circuit may be used for the beat oscillator. Special beat-oscillator transformers are available, usually consisting of a tapped coil with adjustable tuning; these are most conveniently used with circuits such as those shown at Fig. 417-B and -C, with the output taken from "Y." A variable condenser of about 25 μ fd. capacity often is connected between cathode and ground to provide fine adjustment of the beat frequency. The beat oscillator usually is coupled to the second detector through a fixed condenser of a few μ fd. capacity.

The beat oscillator should be well shielded, to prevent coupling to any part of the circuit except the second detector, and to prevent its harmonics from getting into the front end of the receiver and being amplified like regular signals. To this end, the plate voltage should be as low as is consistent with sufficient audio output. If the beat-oscillator output is too low, strong signals will not give a proportionately strong audio response, making the receiver sound as though it is being blocked.

The Radio Amateur's Handbook

While a regenerative second detector may be used to give the audio beat note, this is not desirable, since it requires that the detector be detuned from the i.f. This reduces selectivity and response, especially at the i.f.'s used, and re-introduces the undesirable features of auto-dyne reception.

Automatic Volume Control

Automatic regulation of the gain of the receiver in inverse proportion to the signal strength is a great advantage, especially in 'phone reception. This is readily accomplished in the superheterodyne by using the average rectified voltage developed by the received signal across a resistance in a detector circuit to vary the bias on the r.f. and i.f. amplifier tubes. Since this voltage is proportional to the average amplitude of the detector signal, the gain is reduced as the signal strength is greater. The control will be more complete as the number of stages to which the a.v.c. bias is applied is greater. Control of at least two stages is advisable.

A typical circuit of a diode-triode tye tube used as a combined a.v.c. rectifier, detector and first audio amplifier is shown in Fig. 420. One plate of the diode section of the tube is used for signal detection and the other for a.v.c. rectification. The detector diode plate is connected directly to the "high" side of the i.f. transformer secondary, while the a.v.c. diode plate is fed through the small coupling condenser C_3 . Negative bias resulting from the flow of rectified carrier current is developed across R_4 , the diode load resistor. This negative bias is applied to the grids of the controlled stages through the filtering resistors R_5 , R_6 and R_7 .

It does not matter which of the two diode

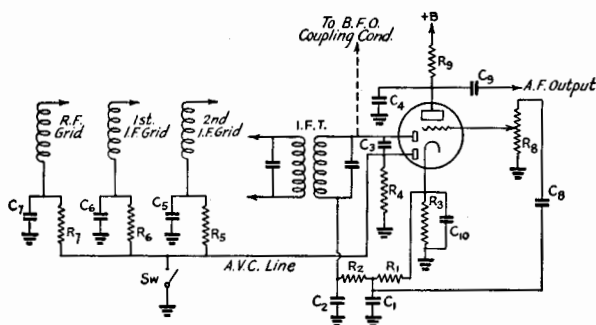

Fig. 420 — Second-detector and first audio circuit with a.v.c., using duo-diode-triode tube.

R_1 — 250,000 ohms, $\frac{1}{2}$ -watt.
 R_2 — 50,000 to 250,000 ohms, $\frac{1}{2}$ -watt.
 R_3 — 2000 ohms, $\frac{1}{2}$ -watt.
 R_4 — 2 to 5 megohms, $\frac{1}{2}$ -watt.
 R_5 , R_6 , R_7 — 1 megohm, $\frac{1}{2}$ -watt.

R_8 — 500,000 ohms, $\frac{1}{2}$ -watt.
 R_9 — 250,000 ohms, $\frac{1}{2}$ -watt.
 C_1 , C_2 , C_3 — 100 μ fd.
 C_4 — 250 μ fd.
 C_5 , C_6 , C_7 — 0.01 μ fd.
 C_8 , C_9 — 0.01 to 0.1 μ fd.
 C_{10} — 5- to 10- μ fd. electrolytic.

plates is selected for audio and which for a.v.c. The audio diode return is made directly to the cathode and the a.v.c. diode return to ground. This places negative bias on the a.v.c. diode equal to the d.c. drop through the cathode resistor (a matter of a volt or two) and thus delays the application of a.v.c. voltage to the amplifier grids, since no rectification takes place in the a.v.c. diode circuit until the carrier amplitude is large enough to overcome the bias. Without this delay, the a.v.c. would start working even with a very small signal, which is undesirable because the full amplification of the receiver then cannot be realized on weak signals. In the audio diode circuit this fixed bias must be avoided, hence the return is made directly to the cathode.

Time constant is important in the a.v.c. circuit, and is determined by the RC values in the diode and bias-feed circuits to the controlled stages. In high-frequency reception a large time constant is not desirable because it prevents the a.v.c. from keeping up with rapid fading. A too-small time constant would tend to "wash out" modulation. The values shown have been found to be satisfactory in operation.

● PRESELECTION

Preselection is added signal-frequency selectivity before the mixer stage is reached. An r.f. amplifier preceding the mixer is generally called a **preselector**, its purpose, in part at least, being to discriminate in favor of the signal against the image. The preselector may consist of one or more r.f. amplifier stages, and its tuning may be ganged with that of the mixer and oscillator. Its circuits must track with the mixer circuit, all being tuned to the same frequency at a given dial setting. An r.f. amplifier stage also improves the signal-to-noise ratio, since the gain is usually greater than that of a mixer while the tube noise is about the same.

The design is the same as discussed earlier in the chapter. An external preselector stage may be used with receivers having inadequate image ratios, in which case it is built as a separate unit, often with a tuned output circuit which gives a further improvement in selectivity.

● CRYSTAL FILTERS

The selectivity of the ordinary i.f. amplifier does not approach the value which it is possible to use in reception of c.w. signals. It does, however, represent about the usable limit for "good quality" 'phone

Reception of Radio Signals

reception, although considerably greater selectivity can be used without sacrificing intelligibility.

The most satisfactory method of obtaining high selectivity is by the use of a piezo-electric quartz crystal as a selective filter in the i.f. amplifier. Compared to a good tuned circuit, the Q of such a crystal is extremely high, so that at a frequency of 450 kc., for instance, the band-width is measured in cycles instead of kilocycles. In practice, the dimensions of the crystal are made such that it is resonant at the desired intermediate frequency, and it is then used as a selective coupler between i.f. stages.

The use of a crystal filter brings another practical advantage — a simple adjustment permits “phasing out” or “rejecting” an interfering signal having a frequency close to, but not the same as, that of the desired signal.

The Single-Signal Effect

As already explained, in c.w. reception the beat oscillator may be set to, say, 456 kc. (if the i.f. is 455 kc.) to give a 1000-cycle beat when the desired signal is on the peak of the i.f. resonance curve. Now if an interfering signal appears at 457 kc. it also will be heterodyned by the beat oscillator to produce a 1000-cycle beat. This **audio-frequency image** corresponds to the high-frequency images already discussed, and can be reduced by providing enough selectivity to make the response to the image negligible.

With selectivity of the order shown in Fig. 401 it is obvious that the ratio of signal to audio-frequency image will not be very high for beat notes of 1000 cycles or less. With a crystal filter, however, the audio-frequency image can be made practically inaudible, even on the strongest signals, by a combination of the high selectivity of the filter with the rejection feature. Fig. 421 gives a typical crystal-filter resonance curve which illustrates this. The audio-frequency image can be reduced by a factor of 1000 or more as compared with the desired signal. There is, in effect, only one heterodyne beat from each signal instead of the two which are observed with normal i.f. selectivity, or with a regenerative autodyne detector.

Besides practically eliminating the a.f. image, the high selectivity of the crystal filter provides great discrimination against signals very close to the desired signal in frequency, and, by reducing the band width, reduces the response of the receiver to noise both from sources external to the receiver and in the r.f. stages of the receiver itself.

Phasing

Several crystal-filter circuits are shown in Fig. 422. Those at *A* and *B* are practically

identical in performance, although differing in details. The crystal is connected in a bridge circuit, with the secondary side of T_1 , the input transformer, balanced to ground either through a pair of condensers, $C-C$, (*A*) or by a center-tap on the secondary, L_2 (*B*). The bridge is completed by the crystal X , and the **phasing condenser**, C_2 , which has a maximum capacity somewhat higher than the capacity of the crystal in its holder. When C_2 is set to balance the crystal-holder capacity (or neutralize the holder capacity) the resonance curve of the crystal circuit is practically symmetrical; the crystal acts as a series resonant circuit of very high Q and thus allows signals of the desired frequency to be fed through C_3 to L_3L_4 , the output transformer. Without C_2 the holder capacity (with the crystal acting as a dielectric) would by-pass signals of undesired frequencies to the output circuit.

The phasing control has an additional function besides neutralization of the crystal-holder capacity, however. The holder capacity becomes a part of the crystal circuit and causes it to act as a parallel-tuned resonant circuit at a frequency slightly higher than its series-resonant frequency. Signals at the parallel-resonant frequency are thus prevented from reaching the output circuit. The phasing control, by varying the effect of the holder capacity, permits shifting the parallel-resonant frequency over a considerable range, thus providing **adjustable rejection** of interfering signals. The effect of rejection is illustrated in Fig. 421, where the audio image is reduced far below the value that would be expected if the resonance curve were symmetrical.

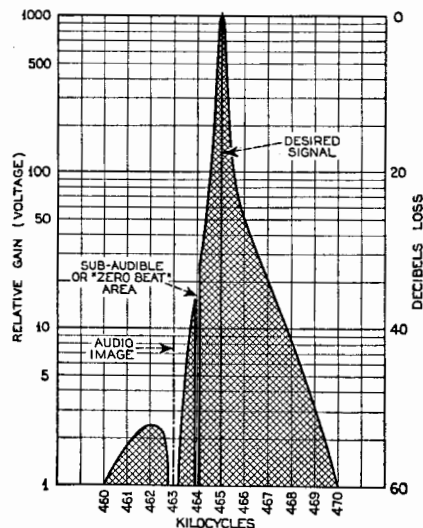

Fig. 421 — A graphical illustration of single-signal selectivity. The shaded area indicates the region in which response is obtainable.

The Radio Amateur's Handbook

Variable Selectivity

In circuits of the type of *A* and *B*, Fig. 422, variable selectivity is obtained by adjustment of the variable input impedance, which is effectively in series with the crystal resonator. This is accomplished by varying C_1 (the selectivity control) which tunes the balanced secondary circuit of T_1 . When the secondary is tuned to i.f. resonance, the parallel impedance of the L_2C_1 combination is maximum and is purely resistive. Since the secondary circuit is center-tapped, approximately one-fourth of this resistive impedance is in series with the crystal, through C_3 and L_4 . This lowers the Q of the crystal circuit and makes its selectivity minimum. At the same time, the voltage applied to the crystal circuit is maximum.

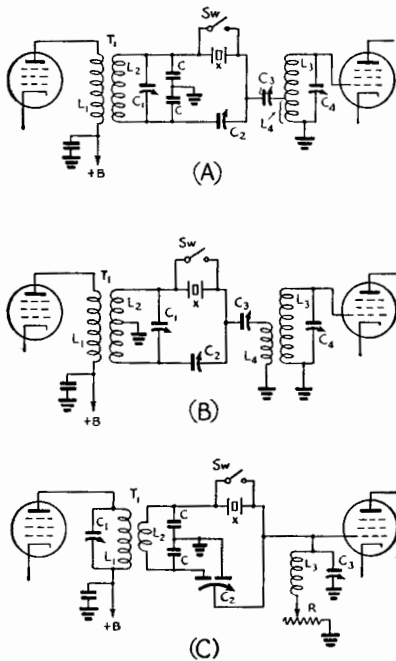

Fig. 422 — Crystal filter circuits of three types. All give variable band-width, with *C* having the greatest range of selectivity. Their operation is discussed in the text. Suitable circuit values are as follows: Circuit *A*, T_1 , special i.f. input transformer with high-inductance primary, L_1 , closely coupled to tuned secondary, L_2 ; C_1 , 50- μ fd. variable; C_2 , each 100- μ fd. fixed (mica); C_3 , 10- to 15- μ fd. (max.) variable; C_4 , 50- μ fd. trimmer; L_3C_4 , i.f. tuned circuit, with L_3 tapped to match crystal-circuit impedance. In Circuit *B*, T_1 is the same as in Circuit *A* except that the secondary is center-tapped; C_1 is 100- μ fd. variable; C_2 , C_3 and C_4 same as for Circuit *A*; L_3L_4 is a transformer with primary, L_4 , corresponding to tap on L_3 in *A*. In Circuit *C*, T_1 is a special i.f. input transformer with tuned primary and low-impedance secondary; C_1 , each 100- μ fd. fixed (mica); C_2 , opposed-stator phasing condenser, app. 8 μ fd. maximum capacity each side; L_3C_3 , high- Q i.f. tuned circuit; R , 0 to 3000 ohms (selectivity control).

When the input circuit is detuned from the crystal resonant frequency, the resistance component of the input impedance decreases, and so does the total parallel impedance. Accordingly, the selectivity of the crystal circuit becomes higher and the applied voltage falls off. At first the resistance decreases faster than the applied voltage, with the result that at first the c.w. output from the filter *increases* as the selectivity is increased. The output then falls off gradually as the input circuit is detuned farther from resonance and the selectivity becomes still higher. The selectivity can be varied over a range of more than 12 to 1, and the maximum selectivity is more than 35 times that obtained with the crystal filter switched out, in typical receivers having two i.f. stages. (*Bib. 1*).

In the circuits of *A* and *B*, Fig. 422, the minimum selectivity is still much greater than that of a normal two-stage 455-kc. amplifier, and it is desirable to provide a wider range of selectivity, particularly for 'phone reception. A circuit which does this is shown at Fig. 422-C. The principle of operation is similar, but a much higher value of resistance can be introduced in the crystal circuit to reduce the selectivity. The output tuned circuit L_3C_3 , must have high Q . A compensated condenser is used at C_2 (phasing) to maintain circuit balance, so that the phasing control does not affect the resonant frequency. The output circuit functions as a voltage divider in such a way that the amplitude of the carrier delivered to the next grid does not vary appreciably with the selectivity setting. The variable resistor, R , may consist of a series of separate fixed resistors selected by a tap switch. (*Bib. 2*).

● REGENERATION IN THE SUPERHET

Regeneration often can be used to advantage in superhet receivers to increase gain and, chiefly, selectivity. When the necessary gain and selectivity can be obtained without regeneration it is advantageous not to use it, since a regenerative circuit requires careful adjustment and represents an operating inconvenience. However, in superhets using a small number of tubes regeneration often is worth while.

When the mixer is the first tube in the receiver, it can be made regenerative to increase the image ratio. With the mixer regenerative, but not oscillating, image ratios comparable to those obtained with a non-regenerative r.f. stage preceding the mixer can be obtained at 14 and 28 Mc. At lower frequencies the improvement is not so great, but images are negligible with the mixer properly regenerative. Fairly careful adjustment of regeneration and tuning usually are necessary each time the frequency is changed appreciably,

Reception of Radio Signals

if the advantages of regeneration in increasing selectivity are to be realized. Regeneration affects the signal-to-noise ratio (first tube and circuit noise) adversely, however.

A tickler coil may be connected in series with the mixer plate and coupled to the grid coil to provide regeneration; in fact, any of the usual regenerative methods may be used. Regeneration may be controlled by varying screen voltage or grid bias, the latter by means of a variable cathode resistor.

In an i.f. stage, regeneration can be used to give a pronounced single-signal effect, particularly when the i.f. is 455 kc. or lower. The resonance curve of an i.f. stage at critical regeneration (just below oscillation) resembles that of a crystal filter, although it is broader at the base and does not have the rejection feature. Regeneration is easily introduced in an i.f. amplifier by providing a small amount of capacity coupling between grid and plate — bringing a short length of wire, connected to the grid, into the vicinity of the plate lead, usually will suffice — and may be controlled by the regular cathode-resistor gain control. When the i.f. is regenerative, it is usually preferable to operate the tube at rather high bias and depend upon the regeneration to bring the gain back to normal. This prevents overloading on strong signals and thereby increases the effective selectivity.

The higher selectivity with regeneration reduces the response to noise, just as in the case of high selectivity produced by other means.

● NOISE INTERFERENCE REDUCTION

Much of the interference experienced in reception of amateur signals is caused by domestic electrical equipment and automobile ignition systems. The interference is of two types in its effects. The first is of the "hiss" type consisting of overlapping pulses, similar in nature to the receiver noise previously discussed. It is largely reduced by high selectivity in the receiver, especially for code reception. The second is the "pistol shot" or "machine gun" type, consisting of separated impulses of high amplitude. The "hiss" type of interference is usually caused by commutator sparking in d.c. and series a.c. motors, while the "shot" type results from separated spark discharges (a.c. power leaks, switch and key clicks, ignition sparks, and the like).

Both "hiss" and "shot" interference may be reduced by use of a receiving antenna system of the "noise reduction" type, where the antenna proper is located remotely from the noise sources and connected to the receiver by a balanced or shielded transmission line which has small pick-up. Other methods may be applied in the receiver itself.

Audio Limiter Circuits

A considerable degree of noise reduction in code reception can be accomplished by limiter arrangements applied to the output circuits of both superhet and regenerative receivers. Such limiters also maintain the signal output nearly constant with fading, the effect for both noise and signal limiting being shown in Fig. 423. Diagrams of typical output limiter circuits are shown in Fig. 424. Circuit *A* employs a triode tube operated at reduced plate voltage (approximately 10 volts) so that it saturates at a low-signal level. The arrangement of *B* has better limiting characteristics. A pentode audio tube is operated at reduced screen voltage (35 volts or so), so that the output power remains practically constant over a grid excitation voltage range of more than 100 to 1. The output limiter systems are simple and adaptable to nearly all receivers. However, they cannot prevent noise peaks from overloading previous circuits and do not bring the noise amplitude down below the level of the signal. (*Bib. 3*).

Series-Valve Noise Limiter

The circuit of Fig. 425 "chops" noise peaks at the second detector of a superhet receiver by means of a biased diode which becomes non-conducting above a predetermined signal level. The audio output of the detector must pass through the diode to the grid of the amplifier tube. The diode would normally be non-conducting with the connections shown were it not for the fact that it is given positive bias from a 30-volt source through the adjustable potentiometer R_3 . Resistors R_1 and R_2 must be fairly large in value to prevent loss of audio signal.

The audio signal from the detector can be considered to modulate the steady diode current, and conduction will take place so long as the diode plate is positive with respect to the cathode. When the signal is sufficiently large to swing the cathode positive with respect to the plate, however, conduction ceases and that portion of the signal is cut off from the audio amplifier. The point at which cut-off occurs can be selected by adjustment of R_3 . By setting R_3 so that the signal just passes through the "valve", noise pulses higher in amplitude than the signal will be cut off. The circuit of Fig. 425-A, using an infinite-impedance detector (one in which the cathode bias resistor also is the audio load resistor, with the plate grounded for audio) gives a positive voltage on rectification. When the rectified voltage is negative, as from the usual diode detector, a different circuit arrangement, shown in Fig. 425-B, is required.

An audio signal of about ten volts is re-

The Radio Amateur's Handbook

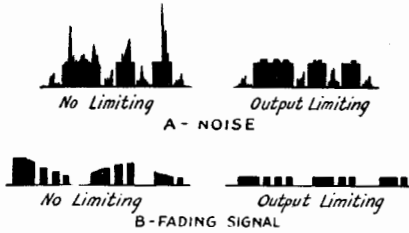

Fig. 423 — Illustrating limiter action with noise-peak interference and with a fading signal.

quired for good limiting action. When a beat oscillator is used for c.w. reception the b.o. voltage should be small so that incoming noise will not have a strong carrier to beat against and produce large audio output. (Bib. 4).

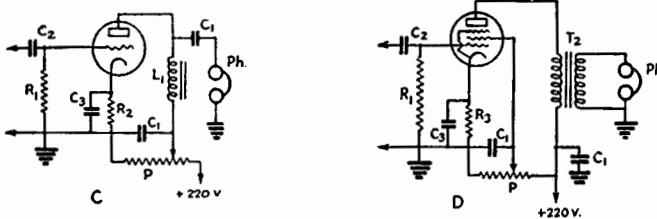

Fig. 424 — Output limiter circuits.

- C_1 — 0.25 μ fd.
- C_2 — 0.01 μ fd.
- C_3 — 5 μ fd.
- P — 50,000-ohm limiter control (preferably wire wound).
- R_1 — 0.5 meg.
- R_2 — 2000 ohms.
- R_3 — 600 ohms.
- T — Output transformer.
- L_1 — 15-henry choke.
- Ph — Telephones (20,000-ohm impedance; 2000-ohm resistance).

Automatic Noise Suppressor Circuit

A second-detector noise limiting circuit which automatically adjusts itself to the received carrier level is shown in Fig. 426. The diode load circuit consists of R_6 , R_7 , R_8 (shunted by the high-resistance audio volume control, R_4) and R_5 in series. The cathode of the 6N7 noise-limiter is tapped on the load resistor at a point such that the average rectified carrier voltage (negative) at its grid is approximately twice the negative voltage at the cathode, both measured with reference to ground. A filter network, R_1C_1 , is inserted in the grid circuit so that the audio modulation on the carrier does not reach the grid, hence the grid potential is maintained at substantially the rectified carrier voltage alone. The

Fig. 425 — The series-valve noise-limiter circuit. A, with an infinite-impedance detector; B, with diode detector. Values are as follows:
 R_1 — 0.25 megohm.
 R_2 — 50,000 ohms.
 R_3 — 10,000-ohm potentiometer.
 R_4 — 20,000 to 50,000 ohms.
 C_1 — 250 μ fd.
 C_2, C_3 — 0.1 μ fd.
 Diode circuit constants in B are conventional.

cathode, however, is free to follow the modulation, and when the modulation is 100% the peak cathode voltage will just equal the steady grid voltage.

At all modulation percentages below 100% the grid is negative with respect to cathode and current cannot flow in the 6N7 plate-cathode circuit. A noise pulse exceeding the peak voltage which represents 100% modulation will, however, make the grid positive with respect to cathode and the relatively-low plate-cathode resistance of the 6N7 shunts the high-resistance audio output circuit, effectively short-circuiting it so that there is practically no response for the duration of the noise peak over the 100% modulation limit.

R_5 is used to make the noise-limiting tube more sensitive, by applying to the plate an audio voltage out of phase with the cathode voltage so that at the instant the grid goes positive with respect to cathode, the highest positive potential also is applied to the plate, thus further lowering the effective plate-cathode resistance. (Bib. 5).

Noise-Silencing I.F. System

The circuit shown in Fig. 427 operates to make the noise pulses "commit suicide" before they have a chance to reach the second detector. Noise voltage in ex-

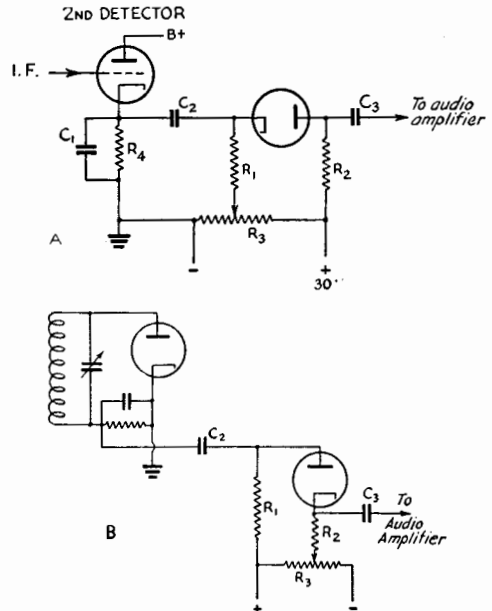

Reception of Radio Signals

cess of the desired signal's maximum i.f. voltage is taken off at the grid of the i.f. amplifier, amplified by the **noise amplifier** stage and rectified by the full-wave diode **noise rectifier**. The noise circuits are tuned to the i.f. The rectified noise voltage is applied as a pulse of negative bias to the No. 3 grid of the 6L7 used as an i.f. amplifier, wholly or partially disabling this stage for the duration of the individual noise pulse, depending on the amplitude of the noise voltage. The noise amplifier-rectifier circuit is biased so that rectification will not start until noise voltage exceeds the desired-signal amplitude, by means of the "threshold control." For reception with automatic volume control, the a.v.c. voltage is also applied to the grid of the noise amplifier to augment this threshold bias. This system of noise silencing gives signal-noise ratio improvement of the order of 30 db (power ratio of 1000) with heavy ignition interference, raising the signal-noise ratio from -10 db without the silencer to +20 db in a typical instance. (Bib. 6).

● SIGNAL STRENGTH AND TUNING INDICATORS

A useful accessory to the receiver is an

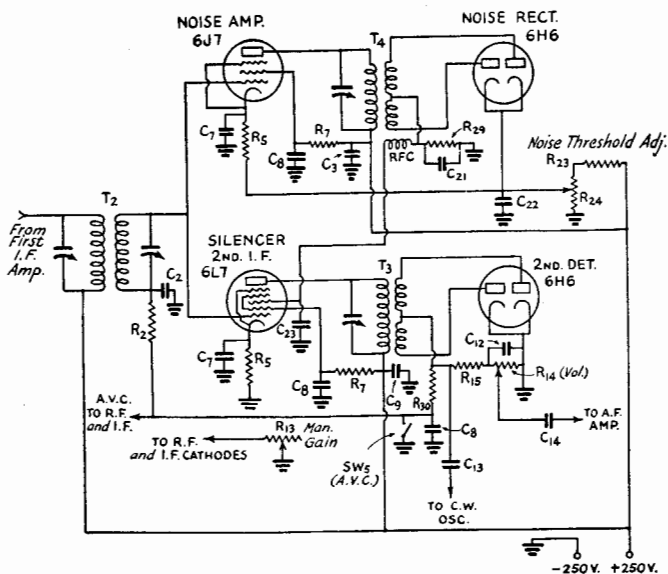

Fig. 427 — Silencer circuit applied to the second i.f. stage of a typical superhet. The negative-B of the high-voltage supply must be grounded at the filter output.

- C₂ — 0.01- μ fd. grid by-pass condenser, 200-volt tubular.
- C₃ — 0.01- to 0.1- μ fd. plate by-pass condenser, 400-volt tubular.
- C₇ — 0.1- μ fd. cathode by-pass condensers, 200-volt tubular.
- C₈ — 0.01- to 0.1- μ fd. screen by-pass condensers, 400-volt tubular.
- C₉ — 0.25- μ fd. main by-pass condenser, 600-volt tubular.
- C₁₂ — 50- μ fd. detector load by-pass, mica midget.
- C₁₃ — 50- μ fd. beat osc. coupling condenser, mica midget.
- C₁₄ — 0.1- μ fd. detector output coupling condenser, 200-volt tubular.
- C₂₁ — 0- to 250- μ fd. noise rectifier load by-pass, mica midget.
- C₂₂ — 0.1- μ fd. threshold resistor by-pass, 200-volt tubular.
- C₂₃ — 50- μ fd. silencer r.f. by-pass, mica midget.
- R₂ — 100,000-ohm grid filtering resistor, $\frac{1}{2}$ -watt.
- R₅ — 350- to 1000-ohm cathode resistors, $\frac{1}{2}$ -watt.
- R₇ — 100,000-ohm screen-voltage dropping resistors, $\frac{1}{2}$ -watt.
- R₁₃ — 500-ohm manual r.f. gain control.
- R₁₄ — 0.25-megohm volume control.
- R₁₅ — 50,000-ohm detector filter resistor, $\frac{1}{2}$ -watt.
- R₂₃ — 20,000-ohm threshold bleeder resistor, 1-watt.
- R₂₄ — 5000-ohm threshold control potentiometer volume-control type.
- R₂₉ — 100,000-ohm noise rectifier load resistor, $\frac{1}{2}$ -watt.
- R₃₀ — 1-megohm a.v.c. filter resistor, $\frac{1}{2}$ -watt.
- RFC — 20-millihenry r.f. choke.
- T₂ — Double air-tuned i.f. transformer.
- T₃ and T₄ — Single air-tuned full-wave diode coupling transformers.

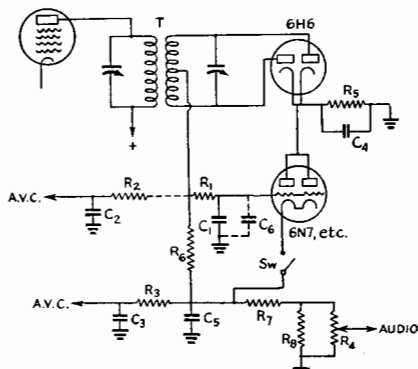

Fig. 426 — Automatic noise limiting circuit for superhet receivers.

- T — I.F. transformer with balanced secondary for working into diode rectifier.
 - R₁, R₂, R₃ — 1 megohm, $\frac{1}{2}$ -watt.
 - R₄ — 1-megohm volume control.
 - R₅ — 250,000 ohms, $\frac{1}{2}$ -watt.
 - R₆, R₈ — 100,000 ohms, $\frac{1}{2}$ -watt.
 - R₇ — 25,000 ohms, $\frac{1}{2}$ -watt.
 - C₁ — 0.1- μ fd. paper.
 - C₂, C₃ — 0.05- μ fd. paper.
 - C₄, C₅ — 50- μ fd. mica.
 - C₆ — 0.001- μ fd. mica (for r.f. filtering, if needed).
 - Sw — S.p.s.t. toggle (on-off switch).
- The switch should be mounted close to the circuit elements and controlled by an extension shaft if necessary.

The Radio Amateur's Handbook

indicator which will show relative signal strength. Not only is it an aid in giving reports, but it also is helpful in aligning the receiver circuits, in conjunction with a test oscillator or other steady signal.

Three types of indicators are shown in Fig.

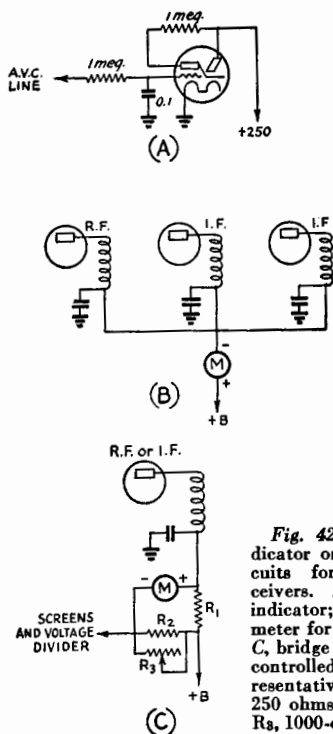

Fig. 428 — Tuning indicator or "S"-meter circuits for superhet receivers. *A*, electron-ray indicator; *B*, plate-current meter for tubes on a.v.c.; *C*, bridge circuit for a.v.c. controlled tube. In *C*, representative values are: R_1 , 250 ohms; R_2 , 350 ohms; R_3 , 1000-ohm variable.

428. That at *A* uses an electron-ray tube, several types of which are available. The grid of

the triode section is usually connected to the a.v.c. line. The particular type of tube to use will depend upon the voltage available for its grid; where the a.v.c. voltage is relatively large, a remote-cutoff type tube should be used in preference to the sharp-cutoff type such as the 6E5.

In *B*, a milliammeter is connected in series with the d.c. plate leads to the r.f. and i.f. tubes whose grids are controlled by a.v.c. Since the plate current of such tubes varies with the strength of the incoming signal, the meter will indicate relative signal intensity and may be calibrated in "S" points. The scale range of the meter should be chosen to fit the number of tubes in use; the maximum plate current of the average remote-cutoff r.f. pentode is from 7 to 10 milliamperes. The disadvantage of this system is that the meter reading decreases with increasing signal strength. The sensitivity also is limited and cannot easily be controlled.

The system at *C* uses a 0-1 milliammeter in a bridge circuit arranged so that the meter reading and signal strength increase together. The current through the branch containing R_1 should be approximately equal to the current through that containing R_2 . In some manufactured receivers this is brought about by draining the screen voltage-divider current and the current to the screens of three r.f. pentodes (r.f. and i.f. stages) through R_2 , the sum of these currents being about equal to the maximum plate current of one a.v.c. controlled tube. Typical values for this type of circuit are given. The sensitivity can be increased by making R_1 , R_2 and R_3 larger. The initial setting is made with the manual gain control set near maximum, when R_3 should be adjusted to make the meter reading zero with no signal.

Bibliography

- ¹ Lamb, "Developments in Crystal Filters for S.S. Superhets," *QST*, November, 1933.
- ² Oram, "Full-Range Selectivity with 455-kc. Quartz Crystal Filter," *QST*, December, 1938.
- ³ Robinson, "Audio Output Limiters for Improving the Signal-to-Noise Ratio in Reception," *QST*, February, 1936.
- ⁴ Bacon, "The Series-Valve Noise Limiter," *QST*, October, 1939.
- ⁵ Dickert, "A New Automatic Noise Limiter," *QST*, November, 1938.
- ⁶ Lamb, "Noise-Silencing I.F. Circuit for Superhet Receivers," *QST*, February, 1936.

Transmitter Design

Design of Crystal-Oscillator, Frequency-Multiplier and Power-Amplifier Circuits — Neutralizing Circuits — Inter-Stage Coupling Systems — Tank-Circuit Design — Amplifier Operating Conditions

THIS chapter deals principally with the design of transmitters to operate at frequencies between 1.75 and 30 Mc.; ultra-high-frequency transmitters will be discussed in a later chapter.

The modern amateur transmitter must be designed to comply with the simple requirements in our regulations regarding purity and stability of the output carrier.

Transmitter Units

The *oscillator* is the frequency-generating unit. It is sometimes used to deliver the radio-frequency power generated to the antenna, although, more often it is used in conjunction with a *power amplifier* which increases the power level at the oscillator frequency before delivering it to the antenna. The third unit type is the *frequency multiplier* which is used to increase the frequency delivered to it by the oscillator or a preceding frequency-multiplying stage. The frequency multiplier may also be referred to as a *doubler*, *tripler* or *quadrupler*, depending upon the order of frequency multiplication. Frequency multipliers are usually followed by a power amplifier which delivers power to the antenna.

● CIRCUIT TERMS

The Tank Circuit

A tuned circuit, consisting of a suitable coil and condenser in parallel, used in conjunction with a vacuum tube in an r.f. oscillator or amplifier, is commonly termed a *tank circuit*.

Fig. 501 — Methods of making return connections to filament center-tap to prevent filament-supply modulation. If R_2 is used to drop filament voltage from higher-voltage transformer, the center-tapped resistance should always be used, even if the transformer is equipped with center-tap.

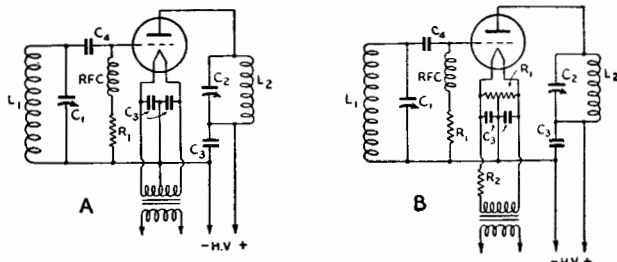

By-Pass and Blocking Condensers

The *by-pass condenser* is used to provide a comparatively low-impedance path for r.f. or a.f. currents around some circuit element or branch.

A *blocking condenser* is used to introduce a high impedance to the flow of low-frequency a.c. or d.c. in some branch of a circuit without appreciably affecting the flow of r.f. currents.

Series and Parallel Feed

The d.c. voltages required for grid and plate in the operation of a vacuum-tube circuit may be fed through the associated tank circuit when it is called *series feed* or through a r.f. choke effectively in parallel with the tank circuit when it is termed *parallel feed*.

Filament Center-Tap

To prevent hum with filament-type tubes operating from a.c. supply, it is necessary to return the grid and plate circuits to the electrical center of the filament circuit as shown in Fig. 501. When no transformer center-tap is provided, or if a series resistance is used in the secondary to drop the filament voltage, a center-tapped resistance should be used as shown at B.

● OPERATING TERMS

Power Input

Unless otherwise specified, the term *power input* applies only to the d.c. power consumed

The Radio Amateur's Handbook

in the plate circuit of the vacuum tube. It is the product of the d.c. plate voltage and current.

Power Output

In using the term *power output*, it is important to distinguish between *tube* power output and *circuit* power output. The former does not include the tank- and coupling-circuit losses.

Efficiency

Plate efficiency is the ratio of power output to power input expressed as a percentage, and usually refers to tube efficiency, neglecting circuit losses.

Excitation

Excitation voltage is the alternating voltage applied to the control-grid circuit of the tube. *Exciting* or *driving power* is the power required to develop the excitation voltage. Oscillators supply their own excitation, while excitation for an amplifier or frequency multiplier must be furnished from an external source.

Frequency Stability

The degree to which the frequency of an oscillator adheres to any single frequency to which it has been set is termed its *frequency stability*. Frequency instability may have origins of three types. Frequency changes may occur with mechanical movement of some circuit element which causes it to change its electrical value whenever the oscillator is subject to mechanical shock or vibration.

The second type of instability is caused by effects of a change in temperature of some circuit element. Thermal effects are usually characterized by a slow progressive change in frequency from the time the oscillator is first placed in operation until some time later when the oscillator reaches a more or less stable temperature. This sort of frequency change is described as *creep*.

The third type of instability is known as *dynamic* and is the result of anything which will change the operating characteristics of the oscillator tube. This may be a change in electrode voltages or a change in the loading of the oscillator which may, in turn, cause a change in the effective input capacity of the tube.

Parasitic Oscillations

Oscillations generated in a transmitter aside from those at the operating frequency are termed *parasitic oscillations*. This type of oscillation invariably causes spurious radiations and also effectively reduces the efficiency of an amplifier.

Oscillators

When the frequency of the oscillator is determined entirely by the circuit constants, it is

called a *self-controlled oscillator*; if the frequency is determined principally by an electro-mechanical device, the piezo-electric crystal, the oscillator is termed a *crystal-controlled oscillator*.

Self-Controlled Oscillators

The advantage of a self-controlled oscillator is its flexibility which permits choice of any frequency desired by simply providing a coil and condenser of suitable values. Its disadvantages are that extreme care in design and adjustment is necessary if satisfactory frequency stability is to be attained. The use of self-controlled oscillators in amateur transmitters should be confined exclusively to the generation of a stable frequency with power output decidedly of minor importance. The most satisfactory type of self-controlled oscillator now in general use is the electron-coupled oscillator which will be described in detail. Brief references to other types will be found in Chapter 3.

The Electron-Coupled Oscillator

In this circuit, a screen-grid tube is used. The screen forms the plate of a Hartley or Colpitts triode oscillator arranged so that the

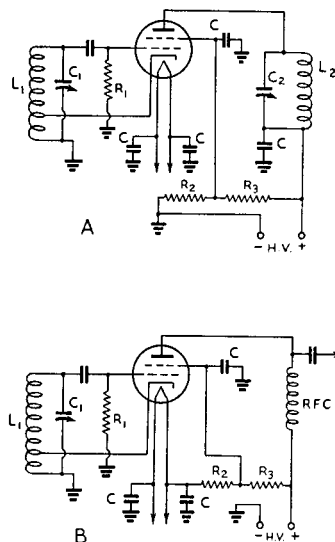

Fig. 502 — The electron-coupled oscillator. The frequency is controlled mainly by the constants of L_1-C_1 which should be a high-C circuit. Feedback is controlled by the position of the cathode tap which must be adjusted carefully under operating conditions. The adjustment of the screen voltage by means of the voltage divider R_2-R_3 is also critical for high-frequency stability. Tuning of L_2-C_2 , which may be a low-C circuit, will also have some effect upon the frequency. Circuit B, in which the tuned plate circuit is replaced by an r.f. choke is usually favored. It is important that a well-screened tube and voltage-regulated plate supply be used.

Transmitter Design

screen, instead of the cathode, is at ground potential. With a well screened tube and good circuit isolation, the coupling between the oscillating circuit and the plate output circuit, from which power is taken, is essentially through the varying electron stream and, therefore, the frequency is more independent of adjustments and loading of the output circuit than with other types, although in practice the effects must still be taken into consideration.

An example of the electron-coupled oscillator is shown in Fig. 502. (*Bib. 1*)

Crystal-Controlled Oscillators

In crystal-controlled oscillator circuits, the usual parallel resonant circuit, which determines the frequency, is replaced by the piezoelectric crystal. If a crystal is properly connected in an oscillator circuit, energy fed back from the output circuit may be used to excite the crystal which, in turn, will generate an alternating voltage which will be applied to the grid of the oscillator tube, and the circuit will oscillate at a frequency controlled, within very close limits, by the dimensions of the crystal.

The disadvantage of the e.c. oscillator is that, with a given crystal, the frequency may be

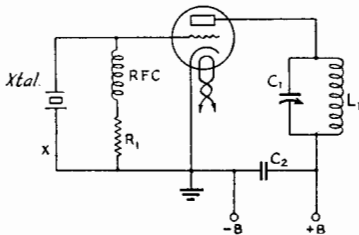

Fig. 503 — Triode crystal oscillator. The tank condenser C_1 may be a 100- $\mu\text{fd.}$ variable, with L_1 proportioned so that the tank will tune to the crystal frequency. (See coil charts, Figs. 516-517.) C_2 should be 0.001 $\mu\text{fd.}$ or larger. The grid leak, R_1 , will vary with the type of tube; high- μ types take lower values, 2500 to 10,000 ohms, while medium and low- μ types take values of 10,000 to 25,000 ohms.

varied over extremely narrow limits (about 5 kc. at 4 Mc. with suitable crystal and holder), making it necessary to provide essentially a separate crystal for each frequency desired in any particular amateur frequency band. Its great advantage is the comparative ease with which satisfactory frequency stability may be obtained.

The Triode Crystal Oscillator

The circuit of a triode crystal oscillator is shown in Fig. 503. It is the equivalent of the tuned-plate tuned grid circuit since the crystal is the equivalent of the grid tank circuit. The limit of plate voltage that can be used without endangering the crystal is about 250 volts. With

the r.f. crystal current limited to a safe value of about 100 ma., as measured by a r.f. galvanometer or low-range r.f. ammeter inserted in series with the crystal (at "x" in the diagram), the power output obtainable is about 5 watts. The oscillation frequency is dependent to a greater extent on the plate tank tuning than is the case with circuits using tetrodes or pentodes.

The Tetrode or Pentode Oscillator

Since the r.f. voltage amplitude (which determines the power output of the oscillator

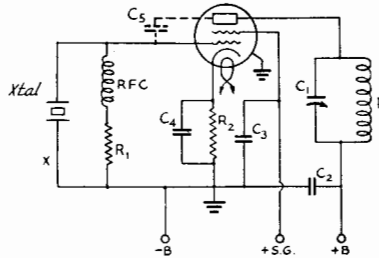

Fig. 504 — Tetrode or pentode crystal oscillator. Typical values: C_1 , 100 $\mu\text{fd.}$ with L wound to suit frequency (see coil charts, Figs. 516-517) with No. 24 wire or larger; C_2 , C_3 , 0.001 $\mu\text{fd.}$ or larger; C_4 , 0.01 $\mu\text{fd.}$; R_1 , 10,000 to 50,000 ohms, best value being determined by trial for the plate voltage and operating conditions chosen; R_2 , 250 to 400 ohms. R_2 and C_4 may be omitted, connecting cathode directly to ground if plate voltage is limited to 250 volts. C_5 may be required to obtain oscillation with a well-screened tube. It may be formed by two metal plates about $\frac{1}{2}$ inch square spaced about $\frac{1}{4}$ inch. If tube has suppressor grid, it should be grounded.

tube) in the grid circuit is limited by the safe vibration amplitude of the crystal, obviously the greatest power output can be secured without danger to the crystal by choosing a tube of high power sensitivity (see Chapter 3). Hence, we find that pentodes and beam tubes are widely used as crystal oscillators in amateur transmitters because, at a given plate voltage, the crystal heating will be less than with a triode and alternatively, for the same amplitude of crystal vibration, higher plate voltages can be used, resulting in greater power output.

Fig. 504 shows a typical pentode or tetrode oscillator circuit. The pentode and tetrode tubes designed for audio power work, such as the 47, 2A5, 41, 42, 6V6G, 6L6G, 6L6, 48 and 6F6 are excellent crystal-oscillator tubes. Tubes having 250-volt ratings may be operated at voltages as high as 300 and screen voltages between 100 and 125 when R_2 and C_4 may be omitted. The larger beam tubes, 6L6 and 807 may be run at 400 to 500 volts on the plate and 250 on the screen for maximum output and the cathode resistor and by-pass should be used.

A thermo-galvanometer (or a 60-ma. dial light) may be connected at "X" to give an indication of r.f. crystal current. Pentode oscil-

The Radio Amateur's Handbook

lators operating at 250 volts will give 4 or 5 watts output under normal conditions. The beam types 6L6 and 807 will give 15 watts or more at maximum plate voltage. (Bib. 2).

The Pierce Oscillator

This circuit, one of the earliest devised for crystal oscillators, is shown in Fig. 505. It operates in the same manner as the old ultraudion circuit with the crystal, instead of a tuned circuit, connected between grid and plate. The plate circuit must be capacitively reactive or tuned to a lower frequency than that of the crystal. The capacity C_2 will usually be required; it introduces an amount of regeneration depending upon its capacity. The output of the Pierce oscillator is relatively small, although it has the advantage that no tuning controls are required. The circuit requires capacitive coupling to a following stage.

Harmonic Generation — The Tri-Tet

Many circuits have been devised to obtain harmonic output from the oscillator tube. One of the most successful is the "Tri-tet" oscillator. The circuit is shown in Fig. 506, in two versions arranged for use with pentodes and beam tetrodes. In the Tri-tet oscillator circuit the screen grid is operated at ground potential while the cathode assumes an r.f. potential above ground. The screen-grid acts as the anode of a triode crystal oscillator, while the plate or output circuit is simply tuned to the oscillator frequency or a multiple of it.

Besides harmonic output, the Tri-tet circuit has the feature of buffering action attributable to electron-coupling between crystal and output circuits. This makes the crystal frequency less susceptible to changes in loading or tuning and hence improves the stability.

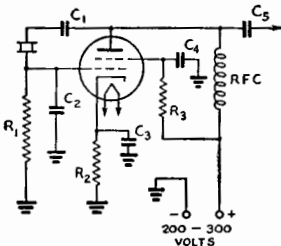
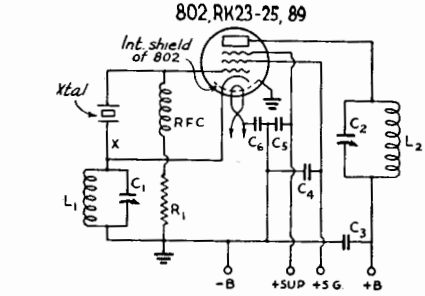

Fig. 505 — The Pierce oscillator requires no tuning controls. Tubes such as the 6C5 and 6F6 are suitable operating at plate voltages not exceeding 300 to prevent crystal fracture. When a triode is used, R_1 and C_4 are omitted. R_1 should have the usual grid-leak values of 25,000 to 50,000 ohms. 1000 ohms is recommended for R_2 . R_3 is the screen voltage dropping resistance, 75,000 ohms for the 6F6. C_1 is a voltage blocking condenser of any value between 0.001 and 0.01 μfd . C_3 and C_4 should be 0.01 μfd . The size of C_2 , the regeneration capacity must be determined by experiment, probably somewhere between 50 and 150 μfd . The size of C_5 , usually 100 μfd , should be adjusted so that the oscillator is not overloaded.



6L6, 6L6G, RK39, 807, 6V6G

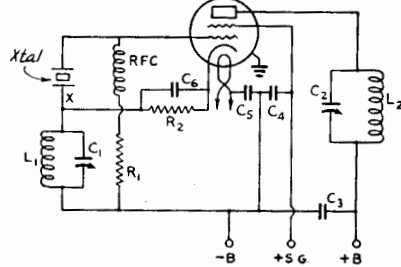

Fig. 506 — Tri-tet oscillator circuit, using pentodes or beam tetrodes. C_1 and C_2 , 200- μfd . variables; C_3 , C_4 , C_5 , 0.001 to 0.01 μfd . by-passes, not critical; R_1 , 20,000 to 100,000 ohms; R_2 , 400 ohms for 400- or 500-volt operation.

Following specifications for cathode coils, L_1 , are based on a coil diameter of $1\frac{1}{2}$ inches and length 1 inch; turns should be spaced evenly to fill the required length. For RK-23, RK-25, 6L6, 6L6G and 6V6G tubes: 1.75-Mc. crystal, 32 turns; 3.5 Mc., 10 turns, 7 Mc., 6 turns. The 6L6G and 6L6 tubes are recommended only for second harmonic operation. For 802, 807, RK-39, and 89 tubes: 1.75-Mc. crystal, 28 turns; 3.5 Mc., 14 turns; 7 Mc., 7 turns.

At maximum recommended plate voltages (500 volts for transmitting types, 400 volts for 6L6 and 6L6G) the screen voltage should be 250. The 89 and 6V6G types may be operated with 300 plate volts and 150 volts on the screen.

The L-C ratio in the plate tank, L_2C_2 , should be adjusted so that the capacity in use is 75 to 100 μfd . for fundamental output and about 25 μfd . for second harmonic output.

If the output circuit is to be tuned to the same frequency as the crystal, a fairly well-screened tube must be used, otherwise there may be excessive feedback and danger of fracturing the crystal. The tubes specified in Fig. 506 meet this condition with the exception of the 6L6G and 6L6, which are recommended only for harmonic operation in the Tri-tet circuit.

The cathode tank circuit, L_1C_1 , is not tuned to the frequency of the crystal, but to a considerably higher frequency. Recommended values for L_1 are given under the diagram. C_1 should be set as near minimum capacity as is consistent with good output. This reduces the crystal voltage.

With pentode-type tubes having separate

Transmitter Design

suppressor connections, the suppressor may be tied directly to ground or may be operated at about 50 volts positive. The latter method will give somewhat higher output than with the suppressor connected to ground.

With transmitting pentodes or beam tubes an output of 15 watts can be obtained on the fundamental and very nearly as much on the second harmonic. (*Bib. 2*).

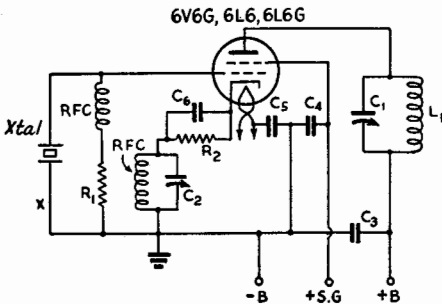

Fig. 507 — Crystal oscillator circuit with grid-plate crystal connection. The screen functions as the plate of a triode oscillator with output taken from the normal plate through a separate tank circuit. Constants are the same as in Fig. 506. For output at the crystal fundamental only, C_2 may be fixed at $100 \mu\text{fd}$.

The Grid-Plate Oscillator

In appearance, the grid-plate oscillator, Fig. 507 resembles the Tri-tet, but with two major differences — the crystal is connected between grid and ground instead of between grid and cathode, and the cathode tuned circuit C_2 RFC is tuned to a lower frequency than that of the crystal.

This circuit is a persistent oscillator and gives high output on the fundamental with low crystal current and is, therefore, in contrast to the Tri-tet, suitable for use with tubes such as the 6L6G and 6L6 operating at the crystal fundamental. The output on even harmonics (2nd, 4th, etc.) is not as great as that obtainable with the Tri-tet; on the other hand, the output on odd harmonics (3rd, 5th, etc.) is appreciably better. This feature may sometimes be put to use in arriving at useful points in the 14- and 28-Mc. bands from a 1.8-Mc. crystal when the oscillator is used in conjunction with a suitable frequency multiplier.

If harmonic operation of the oscillator is not contemplated, C_2 may be a fixed capacity of $100 \mu\text{fd}$. and one tuning control thereby eliminated. The cathode coil, RFC, may be a 2.5-mh. choke, since the inductance is not critical.

Output power of 15 to 20 watts may be obtained at the crystal fundamental with a tube such as the 6L6G at a plate voltage of 400 and screen at 250 volts. Sufficient output is obtain-

able at the 2nd and odd harmonics up to the 7th to drive an 807 frequency multiplier. (*Bib. 5*).

Characteristics and Limitations of Crystals

Crystals having various characteristics, determined by the manner in which they are cut from the raw crystal, are possible. The chief characteristic of the Y-cut crystal is that its frequency usually increases to a limited degree with an increase in temperature. The change may vary from plus 100 cycles per million per degree Centigrade to minus 20 cycles-per-million-per-degree C . The Y-cut type has been largely superseded by other types because of its relative fragility and lack of frequency stability.

The X-cut crystal is thicker than the Y-cut for the same frequency and is, therefore, less fragile. It has a negative temperature coefficient, frequency decreasing with temperature. The change lies between minus 15 and minus 25 cycles-per-million-per-degree C .

More recently, special cuts have been developed which produce crystals with temperature coefficients very close to zero and these are the most favored for amateur use. They are known by various designations, depending upon the particular angle of cut, such as the AT-cut, the V-cut and the LD.

Since some temperature rise occurs in all crystal oscillator circuits developing appreciable power, it is evident that in choosing a crystal frequency near the edge of an amateur band the probable "drift" in frequency must be taken into account.

Heating is greater the greater the amplitude of the crystal vibration; in other words the greater the r.f. voltage across the crystal. When the vibration amplitude is high the internal stresses may be great enough to shatter the crystal, hence the power-handling capabilities of the crystal are limited. A current of 100 ma. r.f. usually is considered safe for X- and Y-cut crystals ground for the 1.75- and 3.5-Mc. bands. Crystals of some types can operate safely with currents as high as 200 ma. The manufacturer usually establishes a safe current rating for his particular cut.

Crystal Mountings

To make use of the crystal, it must be mounted between two metal electrodes. There are two types of mountings, one in which there is an air-gap of about one-thousandth inch between the top plate and the crystal and the other in which both plates are in contact with the crystal. The latter type is generally used by amateurs. It is essential that the surfaces of the metal plates in contact with the crystal be perfectly flat.

A holder having a heavy metal bottom plate with a large surface exposed to the air is ad-

The Radio Amateur's Handbook

vantageous in radiating quickly the heat generated in the crystal and thereby reducing temperature effects.

The type of holder used will have some effect on the frequency of oscillation of the crystal. Different plate sizes, pressures, etc., will cause slight changes, amounting to perhaps a kilocycle or so, so that if a crystal is being ground to an exact frequency it should be tested in the holder and with the same oscillator circuit with which it will be used in the transmitter.

In the air-gap type of holder, the frequency of oscillation depends to some extent upon the size of the gap between the top plate and crystal. This property can be used to advantage with most low-drift crystals so that by using a holder with a top plate with closely adjustable spacing a controllable frequency variation can be obtained. A 3.5-Mc. crystal will oscillate without very great variation in power output over a range of about 5 kc. X- and Y-cut crystals are not generally suitable for this type of operation because they have a tendency to "jump" in frequency with different air gaps.

R.F. Power Amplifiers

As mentioned previously, oscillators as power-generating devices in amateur trans-

mitters have definite limitations. For this reason, amateur transmitters of medium and high power invariably follow the oscillator-power amplifier idea in which the function of the oscillator is essentially one of generating a stable frequency and the small output power is used to excite an amplifier or a series of amplifiers which step the output up to the desired level.

In amateur transmitters, an r.f. amplifier is invariably operated Class C (see Chapter 3). It may employ a single tube or, for greater power output, two tubes in parallel or push-pull. Under similar operating conditions, the power output from two tubes will be the same whether they are connected in parallel or push-pull. The same is true of the power required from the driver. At the higher frequencies a limit is placed on parallel operation by the shunting effect of tube capacities in increasing the minimum capacity of the circuit to such an extent that a tank circuit of reasonable efficiency cannot be secured. The symmetry of push-pull circuits makes them easier to handle in operation. An inherent property of this type of amplifier is its ability to balance out even harmonics, thereby reducing undesirable harmonic output. The tube input and output capacities with this connection are effectively in series.

Interstage Coupling Systems

The purpose of an interstage coupling system is to transfer, with as little loss as possible, the power developed by the driving tube to the grid circuit of the following amplifier or frequency multiplier. While there are many variations, coupling systems in amateur transmitters are usually confined to two general classes, capacitive coupling and transmission-line or link coupling.

Fig. 508 shows several types of capacitive coupling. In each case, *C* is the coupling condenser. In circuit A, the plate of the driver is series fed, while the grid of the amplifier is parallel-fed. The coupling condenser serves also as a blocking condenser to isolate the d.c. plate voltage of the driver from the grid of the amplifier. In circuit B, parallel feed is used in the plate circuit of the driver and series feed in the grid circuit of the amplifier. The circuits of C and D are preferable when a balanced circuit is used in the output of the driver; instead of both being in parallel across one side, the output capacity of the driver tube and the input capacity of the amplifier are across opposite sides of the tank circuit, thereby preserving

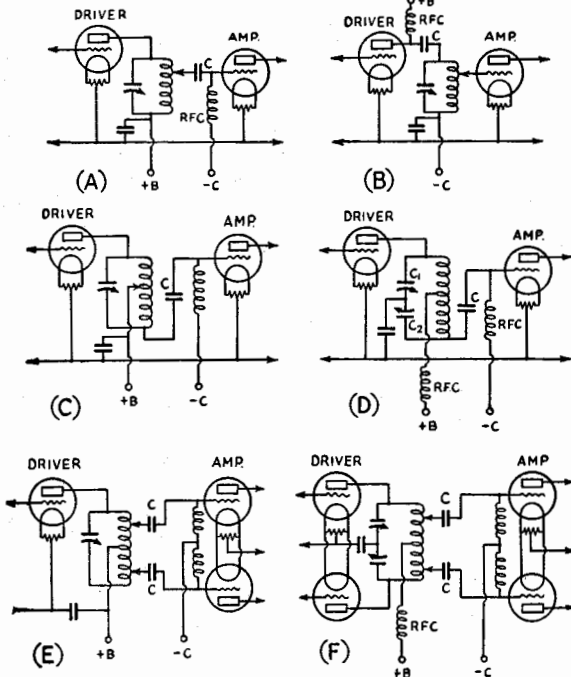

Fig. 508 — Direct- or capacity-coupled driver and amplifier stages. Coupling condenser capacity may be from 50 $\mu\text{fd.}$ to 0.002 $\mu\text{fd.}$, not critical, except when tapping the coils for control of excitation is not possible.

Transmitter Design

a better circuit balance. The circuits of *E* and *F* are designed for coupling to a push-pull stage.

In *A*, *B*, *E* and *F*, excitation is adjusted by moving the tap on the coil, greater excitation up to the limit of the driver being obtained by moving the tap nearer the plate end of the coil. In *E* and *F*, the two grid taps should be maintained equidistant from the center-tap on the coil.

While capacitive coupling is simplest from the viewpoint of construction, it has certain disadvantages which may make it desirable to use another form of coupling in many cases. The input capacity of the amplifier is effectively shunted across at least a portion of the preceding tank coil. When added to the output capacity of the driver tube, this additional capacity may be sufficient, in many cases, to be of serious consequence in circuits for frequencies above about 7 Mc.

Link Coupling

At the higher frequencies it is advantageous to use separate tank circuits for the driver plate and amplifier grid. This avoids paralleling the tube capacities across one circuit, and when the two are coupled through an untuned low-impedance transmission line, offers a ready means for adjustment of coupling. This method of coupling also has some constructional advantages, in that separate parts of the transmitter may be constructed as separate units without the necessity for running long leads at high r.f. potential.

The form of transmission-line coupling utilizing a low-impedance line with coupling loops at a turn or two at each end is popularly known as "link" coupling. The transmission line may be of any convenient length—from a few inches to several feet—without appreciable loss of power in the transfer.

Circuits for link coupling are shown in Fig. 509. The coupling ordinarily is by a turn or two of wire, with ends connected to the twisted pair, closely coupled to the tank inductance at a point of low r.f. potential such as the center of the coil of a balanced tank circuit, or the "ground" end of the coil in a single-ended circuit.

Because of the low impedance of the line, one turn often suffices if the coupling is tight enough; however, sometimes more than one is needed for maximum power transfer. It is advisable, especially with high-power stages, to have some means of varying the coupling between link and tank coil. The link turn may be arranged to be swung in relation to the tank coil or, when it consists of a large turn around the outside of the tank coil, can be split into two parts which can be pulled apart or closed somewhat in the fashion of a pair of calipers.

If the tank coils are wound on forms, the link may be wound close to the main coil.

With fixed coupling, the only adjustment of excitation is by varying the number of turns on the link. If the coupling between link and tank is variable, change of physical separation of the two coils also will give some adjustment of excitation. In general the proper number of turns for the link must be found by experiment.

Tetrode and Pentode Amplifiers

Since the input and output circuits of an r.f. amplifier are tuned to the same frequency, it will oscillate as a t.g.t.p. oscillator (see Chapter 3) unless some means is provided to reduce the plate-to-grid capacity of the tube to a value which will not permit sufficient feed-back, by this means, for oscillation.

In all transmitting r.f. tetrodes and pentodes, this capacity is reduced to a satisfactory degree by the internal shielding between grid and plate provided by the screen grounded for r.f. It should be noted here that tetrodes and pentodes designed for audio use, such as the 6L6, 6V6, 6F6, etc., are not sufficiently well screened for use as r.f. amplifiers without the introduction of other means of nullifying the effect of the grid-plate capacity.

Typical circuits of tetrode and pentode r.f.

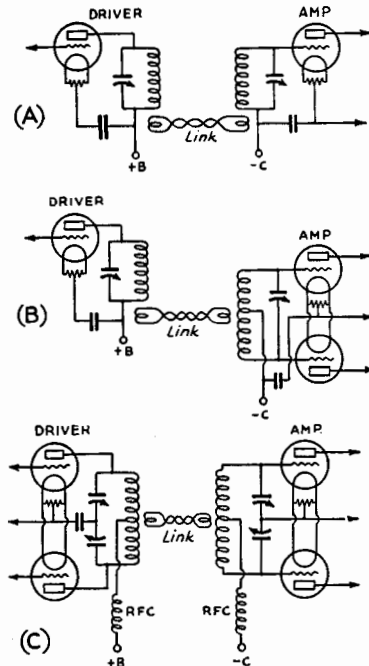

Fig. 509 — Link coupling, using a low-impedance transmission line. The link may be twisted lamp cord or consist of a pair of closely-spaced, but not twisted, wires. A concentric line is the best form.

The Radio Amateur's Handbook

amplifiers are shown in Fig. 510. The relative simplicity of the circuit used with these tubes and the small driving power required are the advantages over triode amplifiers. The high power sensitivity of pentodes and tetrodes, however, makes them prone to self-oscillate, so that particular care must be used to prevent feedback external to the tube itself.

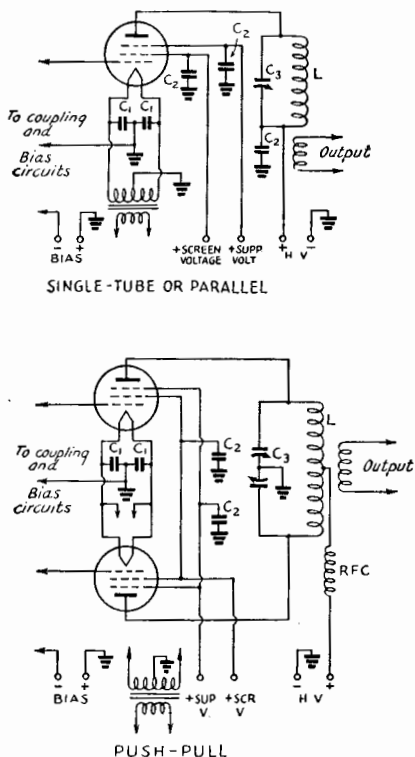

Fig. 510 — Tetrode-pentode r.f. amplifier circuits. C_1 — 0.01 μ f.; C_2 — 0.001 μ f. or larger; C_3 -L — See section on tank-circuit design.

In circuits for tetrodes, the suppressor-grid connection and by-pass are omitted.

Triode Amplifiers

Triodes of equivalent power output rating are less expensive than tetrodes or pentodes. Their input and output capacities are usually lower, which may make them preferable at the higher frequencies. Since the power sensitivity is much lower, considerably greater driving power is required, although, for the same reason, difficulties with stray couplings between input and output circuits are reduced and the absence of the screen-grid eliminates possible trouble in grounding. The d.c. power which must be wasted in operating the screen is eliminated.

Neutralization

On the other hand, special means must be provided for nullifying the effects of grid-to-plate capacity which would otherwise cause self-oscillation. Nullification of these effects is called *neutralization*.

Neutralization really amounts to taking some of the radio-frequency voltage from the output or input circuit of the amplifier and introducing it into the other circuit in such a way that it effectively "bucks" the voltage operating through the grid-plate capacity of the tube, thus rendering it impossible for the tube to supply its own excitation. For complete neutralization it is necessary, therefore, that the neutralizing voltage be opposite in phase to the voltage through the grid-plate capacity of the tube and be equal to it in amplitude.

The out-of-phase voltage can be obtained quite readily by using a balanced tank circuit in either grid or plate, taking the neutralizing voltage from the end of the tank opposite that to which the grid or plate is connected. The amplitude of the neutralizing voltage can be regulated by means of a small condenser, the *neutralizing condenser*, having the same order of capacity as the grid-plate capacity of the tube. Circuits in which the neutralizing voltage is obtained from a balanced grid tank and fed to the plate through the neutralizing condenser are termed *grid-neutralizing* circuits, while if the neutralizing voltage is obtained from a balanced plate tank and fed to the grid of the tube, the circuit is known as a *plate-neutralized* circuit.

Triode Amplifiers with Plate Neutralization

Typical triode amplifier circuits with plate neutralization are shown in Fig. 511-A, -B and -C. In circuit A, the usual tank coil is extended several turns to provide a "neutralizing coil" which provides the out-of-phase voltage which is fed back to the grid through the neutralizing condenser C_n . At B, the tank coil itself is split. The balance can also be capacitive, by the use of a split-stator tank condenser with grounded rotor, as shown in C.

Triode Amplifiers with Grid Neutralization

Typical circuits employing grid neutralization are shown in Fig. 511-D, -E and -F. They resemble those circuits with plate neutralization except that the neutralizing voltage is obtained from a balanced input tank and fed to the plate of the tube. Circuit D is used with capacity coupling between driver and amplifier.

Push-Pull Triode Amplifiers

Push-pull triode amplifiers employ what is known as "cross-neutralization," the neutraliz-

Transmitter Design

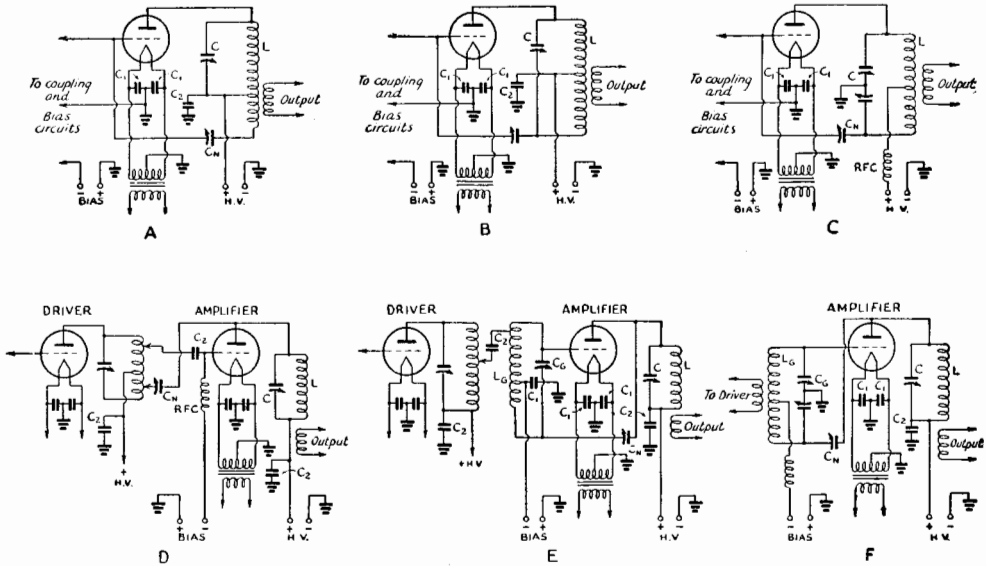

Fig. 511 — Triode amplifier circuits. Plate neutralization is shown in A, B and C, while D, E, and F show types of grid neutralization. Capacitive or link coupling may be used with circuits of A, B or C. C-L — See section on tank-circuit design. C_G-L_G — Grid tank circuit. C_N — Neutralizing condensers (see text). C_1 — 0.01 μ fd. C_2 — 0.001 μ fd. or larger.

ing condensers being connected from grid of one tube to plate of the other. Two circuits are shown in Fig. 512. In A, the voltage division is by the inductive method, while capacitive voltage division is used in the circuit of B.

With proper physical arrangement of parts, a more exact balance can be obtained with push-pull than with a single tube because both sides of the circuit are symmetrical. Hence these circuits are often easier to neutralize than single-tube circuits.

Comparison of Neutralizing Circuits

Plate neutralization is usually to be preferred to grid neutralization because it is more difficult to maintain an accurate balance in the grid circuit with one side of the circuit heavily loaded when the tube draws grid current.

Of the plate neutralizing circuits, the one of Fig. 511-C is preferred because with inductive voltage division, exact neutralization can be obtained at only one frequency. The split-stator circuit also has the advantages that the input capacity of the tube is reduced, harmonics are more effectively suppressed and "hand-capacity effects" of an ungrounded condenser

Fig. 512 — Push-pull triode amplifier circuits with "cross-neutralization." Either capacitive or link coupling may be used.

C-L — See section on tank-circuit design. C_N — Neutralizing condensers (see text). C_1 — 0.01 μ fd. C_2 — 0.001 μ fd. or larger.

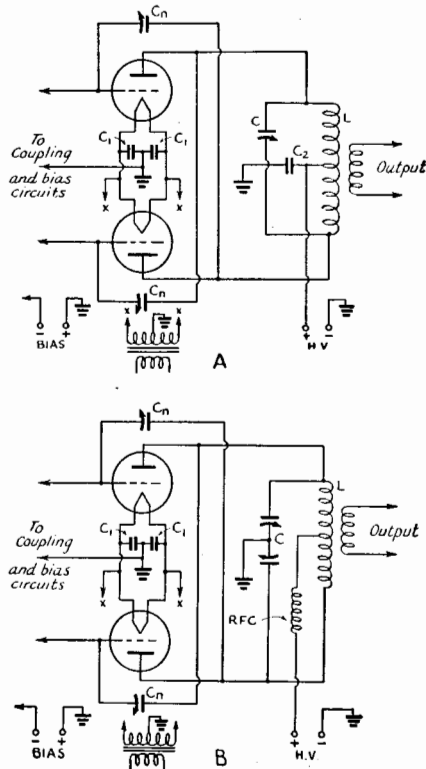

The Radio Amateur's Handbook

shaft are avoided. While an amplifier using the circuit of *B* may appear easier to drive compared to circuit *C* because of effects of regeneration when the tank circuit of *B* is tuned slightly off resonance, with proper neutralization, there should be no difference. With push-pull amplifiers, the circuit of Fig. 512-*B* is also preferred for the same reasons.

Neutralizing Condensers

In most cases the neutralizing voltage will be equal to the r.f. voltage between the plate and grid of the tube so that for perfect balance the capacity required in the neutralizing condenser theoretically will be equal to the grid-plate capacity of the tube being neutralized. If, in the circuits having tapped tank coils, the tap is more than half the total number of turns from the plate end of the coil, the required neutralizing capacity will increase approximately in proportion to the relative number of turns in the two sections of the coil.

For those tubes having grid and plate connections brought out through the bulb, a condenser having at about half-scale or less a capacity equal to the grid-plate capacity of the tube should be chosen. Where the grid and plate leads are brought through a common base, the capacity needed is greater because the tube socket and its associated wiring adds some capacity to the actual inter-element capacities. In such cases a slightly larger condenser should be used.

When two or more tubes are connected in parallel, the neutralizing capacity required will be in proportion to the number of tubes.

Tank-Circuit Design

So far as the plate efficiency of the tube itself is concerned, it does not matter how the load resistance is obtained; that is, the tube will work equally well into an actual resistor or into a tank circuit having any practicable constants so long as the resistance or impedance represented by the tank is the desired value. However, the distribution of the power output between the tank circuit and the load is affected by the inherent (unloaded) impedance of the tank circuit.

The impedance of the unloaded tank circuit at resonance is equal to L/CR , where L is the inductance, C the capacity, and R the effective resistance. The higher the ratio of the unloaded tank impedance to the optimum load impedance for the tube, the greater the proportion of power transferred to the load. The impedance of the tank alone should be at least ten times the optimum load impedance for high transfer efficiency. The unloaded tank impedance can be made high in two ways: by lowering the resistance through the construction of low-loss coils and by careful placement of parts, or by

raising the $L-C$ ratio. With practicable circuits, it is much easier to obtain high tank impedance by using a high $L-C$ ratio than by attempting to reduce the resistance, although every effort should of course be made to reduce losses.

Tank Impedance and Harmonic Output

When a high-impedance tank circuit is used, along with high grid bias and large values of excitation voltage, a large proportion of the power output is on harmonics of the fundamental frequency.

Should the circuit conditions be such that the harmonics cause circulating currents, there is a power loss which reduces the overall efficiency of the amplifier. In general, it will be found that any means employed in the output circuit to reduce harmonics also will result in an improvement in efficiency. A fair amount of flywheel effect also improves the stability of the amplifier and makes its tuning more satisfactory.

Because harmonic reduction calls for considerable flywheel effect, and consequently for a fairly large ratio of capacity to inductance, while high transfer efficiency requires high unloaded tank impedance (high $L-C$ ratio) in practice a compromise must be made between these two conflicting factors.

The amateur is chiefly concerned with the harmonic energy radiated because of the danger of interference to services operating in frequencies not assigned to amateurs. The radiation of harmonics is influenced by the type of antenna, its feed system, and the method of coupling between the antenna system and the final amplifier as well as the tank-circuit $L-C$ ratio and the excitation voltage so that it is obviously impossible to fix rigid rules for determining the value of capacity to be used in the tank circuit. Some sort of compromise is struck by basing tank-capacity calculations on a circuit "Q" of 12. Too much faith should not be placed in this figure, however, because it does not take into consideration wave shape upon which the harmonic content in the output chiefly depends. It represents a fair average, however, and if serious harmonic radiation is experienced, it can usually be reduced satisfactorily by proper adjustment of the antenna system and its coupling to the final amplifier. (See Chaps. 14 and 22.)

The capacity required to give a "Q" of 12 may be determined from the chart of Fig. 513. It is necessary only to know the plate voltage and plate current in ma. at which the amplifier is to operate. If a push-pull amplifier is used, or the tank coil tapped at the center or a split-stator condenser used for neutralizing, the total tank capacity may be reduced to one-quarter of the values given by the graph. This

Transmitter Design

means that the capacity of *each section* of a split-stator condenser will be one-half of the capacity shown by the graph. In determining the ratio of plate voltage to plate current, it should be remembered that the plate current of tubes in parallel or push-pull will be twice that of a single tube.

As an example, a beam tube, not requiring a balanced tank circuit for neutralization, operating at 1000 volts, 100 ma. (ratio 10/1) will require a tank capacity of 100 $\mu\text{fds.}$ for 3.5 Mc. Two similar tubes in parallel (200 ma. — ratio 5/1) will require 200 $\mu\text{fds.}$ Two similar tubes in push-pull (ratio 5/1) will require a total tank capacity of $\frac{200}{4}$ or 50 $\mu\text{fds.}$ and if a split-stator condenser is used, the capacity should be 100 $\mu\text{fds.}$ per section.

As a second example, a triode requiring a balanced tank circuit for neutralization op-

erating at 1000 volts, 100 ma. (ratio 10/1) will require a total capacity of 25 $\mu\text{fds.}$ or 50 $\mu\text{fds.}$ per section if a split-stator condenser is used. Two similar triodes in parallel (ratio 5/1) will require a total of 50 $\mu\text{fds.}$ or 100 $\mu\text{fds.}$ per section if a split-stator condenser is used. Two similar triodes in push-pull (ratio 5/1) will require the same capacities.

Reasonable departures from these figures would not affect the operation of the amplifier appreciably. An increase in capacity will cause some decrease in both transfer efficiency and harmonic output, while a decrease in the capacity will have the opposite effects. The increase in harmonic radiation with less capacity might be controlled by proper antenna coupling.

Tank-Condenser Voltage Rating

The peak voltage to be expected between the plates of a tank condenser depends upon the arrangement of the tank circuit as well as the d.c. plate voltage of the tube or tubes in use. Peak voltage may be determined from Fig. 514 which shows all of the commonly used tank-circuit arrangements. These estimates of voltage assume that the amplifier is loaded. Since a c.w. amplifier may be tuned up without load with a resulting rise in peak r.f. voltage, while a modulated amplifier should never be operated without load, the voltage for phone should be used in selecting a suitable tank condenser for either c.w. or phone unless tuning of the c.w. amplifier is done at reduced plate voltage. The figures include a reasonable factor of safety.

The spacing required to withstand any particular voltage will vary with the construction of the condenser. Most manufacturers specify peak voltage ratings for their condensers.

Determining Inductance

Once the required tank capacity and frequency are determined, the tank coil dimensions can be found. This may be done with the help of the L - C and inductance formulas in Chapter 20, or if standard coil forms are used, the charts of Figs. 516 and 517 will give the required number of turns directly. Using the chart which applies for the type of coil form or coil in question, read on the appropriate frequency curve the number of turns required for the tank capacity value already determined. The optimum tank LC ratio will result.

Fig. 516 is for coils wound on receiving-type forms having a diameter of $1\frac{1}{2}$ inches and ceramic forms having a diameter of $1\frac{3}{4}$ inches and winding length of 3 inches (National XR13). Such coils would be suitable for oscillator and buffer stages where the power to be carried is not over 50 watts. In all cases the number of turns given must be wound to fit

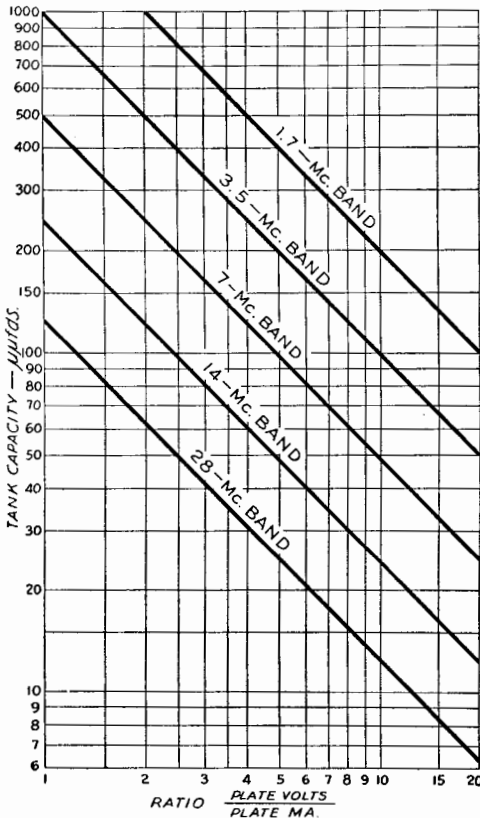

Fig. 513. — Chart showing tank-capacities required for "Q" of 12 with various ratios of plate voltage to plate current for various frequencies. In circuits F, G, H (Fig. 514), the capacities shown in the graph may be divided by four. In circuits C, D, E, I, J and K, the capacity of each section of the split-stator condenser may be one-half that shown by the graph. Values given by the graph should be used for circuits A and B.

Transmitter Design

a better circuit balance. The circuits of *E* and *F* are designed for coupling to a push-pull stage.

In *A*, *B*, *E* and *F*, excitation is adjusted by moving the tap on the coil, greater excitation up to the limit of the driver being obtained by moving the tap nearer the plate end of the coil. In *E* and *F*, the two grid taps should be maintained equidistant from the center-tap on the coil.

While capacitive coupling is simplest from the viewpoint of construction, it has certain disadvantages which may make it desirable to use another form of coupling in many cases. The input capacity of the amplifier is effectively shunted across at least a portion of the preceding tank coil. When added to the output capacity of the driver tube, this additional capacity may be sufficient, in many cases, to be of serious consequence in circuits for frequencies above about 7 Mc.

Link Coupling

At the higher frequencies it is advantageous to use separate tank circuits for the driver plate and amplifier grid. This avoids paralleling the tube capacities across one circuit, and when the two are coupled through an untuned low-impedance transmission line, offers a ready means for adjustment of coupling. This method of coupling also has some constructional advantages, in that separate parts of the transmitter may be constructed as separate units without the necessity for running long leads at high r.f. potential.

The form of transmission-line coupling utilizing a low-impedance line with coupling loops of a turn or two at each end is popularly known as "link" coupling. The transmission line may be of any convenient length — from a few inches to several feet — without appreciable loss of power in the transfer.

Circuits for link coupling are shown in Fig. 509. The coupling ordinarily is by a turn or two of wire, with ends connected to the twisted pair, closely coupled to the tank inductance at a point of low r.f. potential such as the center of the coil of a balanced tank circuit, or the "ground" end of the coil in a single-ended circuit.

Because of the low impedance of the line, one turn often suffices if the coupling is tight enough; however, sometimes more than one is needed for maximum power transfer. It is advisable, especially with high-power stages, to have some means of varying the coupling between link and tank coil. The link turn may be arranged to be swung in relation to the tank coil or, when it consists of a large turn around the outside of the tank coil, can be split into two parts which can be pulled apart or closed somewhat in the fashion of a pair of calipers.

If the tank coils are wound on forms, the link may be wound close to the main coil.

With fixed coupling, the only adjustment of excitation is by varying the number of turns on the link. If the coupling between link and tank is variable, change of physical separation of the two coils also will give some adjustment of excitation. In general the proper number of turns for the link must be found by experiment.

Tetrode and Pentode Amplifiers

Since the input and output circuits of an r.f. amplifier are tuned to the same frequency, it will oscillate as a t.g.t.p. oscillator (see Chapter 3) unless some means is provided to reduce the plate-to-grid capacity of the tube to a value which will not permit sufficient feed-back, by this means, for oscillation.

In all transmitting r.f. tetrodes and pentodes, this capacity is reduced to a satisfactory degree by the internal shielding between grid and plate provided by the screen grounded for r.f. It should be noted here that tetrodes and pentodes designed for audio use, such as the 6L6, 6V6, 6F6, etc., are not sufficiently well screened for use as r.f. amplifiers without the introduction of other means of nullifying the effect of the grid-plate capacity.

Typical circuits of tetrode and pentode r.f.

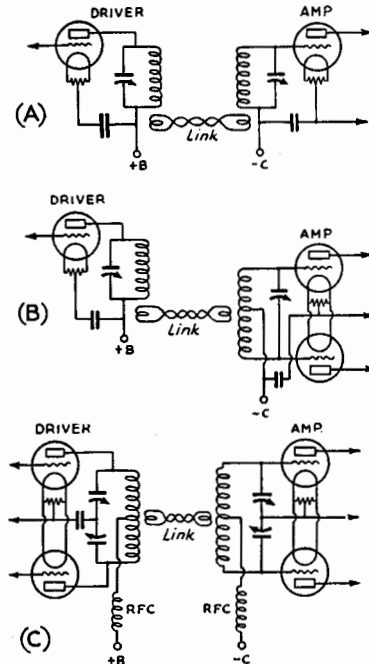

Fig. 509 — Link coupling, using a low-impedance transmission line. The link may be twisted lamp cord or consist of a pair of closely-spaced, but not twisted, wires. A concentric line is the best form.

The Radio Amateur's Handbook

amplifiers are shown in Fig. 510. The relative simplicity of the circuit used with these tubes and the small driving power required are the advantages over triode amplifiers. The high power sensitivity of pentodes and tetrodes, however, makes them prone to self-oscillate, so that particular care must be used to prevent feedback external to the tube itself.

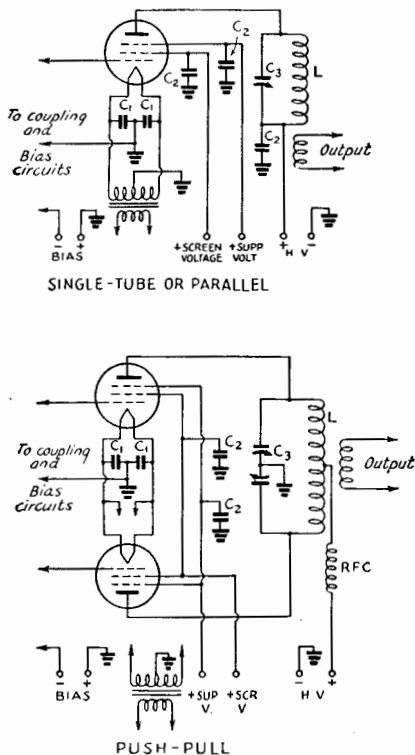

Fig. 510 — Tetrode-pentode r.f. amplifier circuits. C_1 — 0.01 μ d.; C_2 — 0.001 μ d. or larger; C_3 -L — See section on tank-circuit design. In circuits for tetrodes, the suppressor-grid connection and by-pass are omitted.

Triode Amplifiers

Triodes of equivalent power output rating are less expensive than tetrodes or pentodes. Their input and output capacities are usually lower, which may make them preferable at the higher frequencies. Since the power sensitivity is much lower, considerably greater driving power is required, although, for the same reason, difficulties with stray couplings between input and output circuits are reduced and the absence of the screen-grid eliminates possible trouble in grounding. The d.c. power which must be wasted in operating the screen is eliminated.

Neutralization

On the other hand, special means must be provided for nullifying the effects of grid-to-plate capacity which would otherwise cause self-oscillation. Nullification of these effects is called *neutralization*.

Neutralization really amounts to taking some of the radio-frequency voltage from the output or input circuit of the amplifier and introducing it into the other circuit in such a way that it effectively "bucks" the voltage operating through the grid-plate capacity of the tube, thus rendering it impossible for the tube to supply its own excitation. For complete neutralization it is necessary, therefore, that the neutralizing voltage be opposite in phase to the voltage through the grid-plate capacity of the tube and be equal to it in amplitude.

The out-of-phase voltage can be obtained quite readily by using a balanced tank circuit in either grid or plate, taking the neutralizing voltage from the end of the tank opposite that to which the grid or plate is connected. The amplitude of the neutralizing voltage can be regulated by means of a small condenser, the *neutralizing condenser*, having the same order of capacity as the grid-plate capacity of the tube. Circuits in which the neutralizing voltage is obtained from a balanced grid tank and fed to the plate through the neutralizing condenser are termed *grid-neutralizing* circuits, while if the neutralizing voltage is obtained from a balanced plate tank and fed to the grid of the tube, the circuit is known as a *plate-neutralized* circuit.

Triode Amplifiers with Plate Neutralization

Typical triode amplifier circuits with plate neutralization are shown in Fig. 511-A, -B and -C. In circuit A, the usual tank coil is extended several turns to provide a "neutralizing coil" which provides the out-of-phase voltage which is fed back to the grid through the neutralizing condenser C_n . At B, the tank coil itself is split. The balance can also be capacitive, by the use of a split-stator tank condenser with grounded rotor, as shown in C.

Triode Amplifiers with Grid Neutralization

Typical circuits employing grid neutralization are shown in Fig. 511-D, -E and -F. They resemble those circuits with plate neutralization except that the neutralizing voltage is obtained from a balanced input tank and fed to the plate of the tube. Circuit D is used with capacity coupling between driver and amplifier.

Push-Pull Triode Amplifiers

Push-pull triode amplifiers employ what is known as "cross-neutralization," the neutraliz-

Transmitter Design

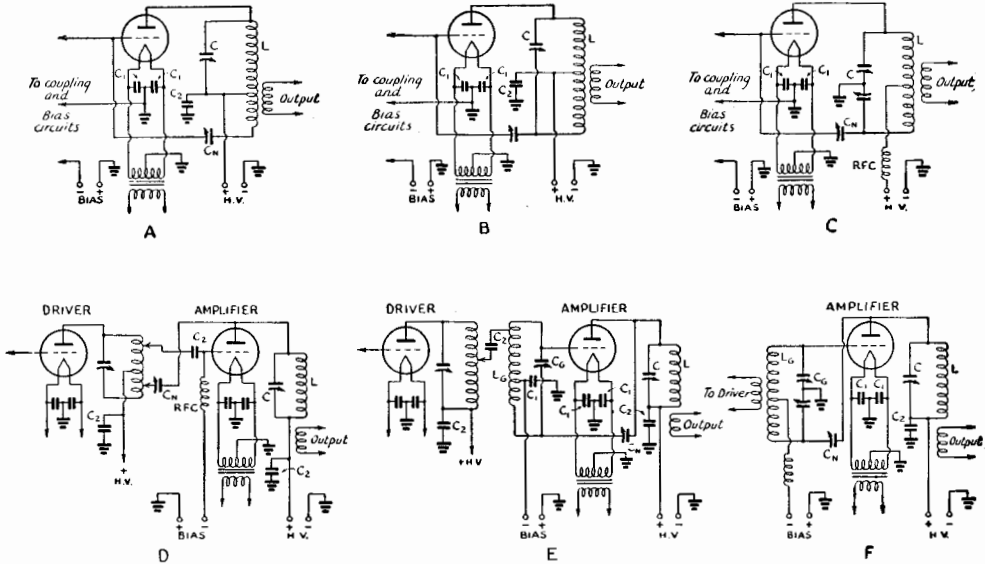

Fig. 511 — Triode amplifier circuits. Plate neutralization is shown in A, B and C, while D, E, and F show types of grid neutralization. Capacitive or link coupling may be used with circuits of A, B or C.
 C-L — See section on tank-circuit design.
 C_G-L_G — Grid tank circuit.
 C_N — Neutralizing condensers (see text).
 C₁ — 0.01 μ fd.
 C₂ — 0.001 μ fd. or larger.

ing condensers being connected from grid of one tube to plate of the other. Two circuits are shown in Fig. 512. In A, the voltage division is by the inductive method, while capacitive voltage division is used in the circuit of B.

With proper physical arrangement of parts, a more exact balance can be obtained with push-pull than with a single tube because both sides of the circuit are symmetrical. Hence these circuits are often easier to neutralize than single-tube circuits.

Comparison of Neutralizing Circuits

Plate neutralization is usually to be preferred to grid neutralization because it is more difficult to maintain an accurate balance in the grid circuit with one side of the circuit heavily loaded when the tube draws grid current.

Of the plate neutralizing circuits, the one of Fig. 511-C is preferred because with inductive voltage division, exact neutralization can be obtained at only one frequency. The split-stator circuit also has the advantages that the input capacity of the tube is reduced, harmonics are more effectively suppressed and "hand-capacity effects" of an ungrounded condenser

Fig. 512 — Push-pull triode amplifier circuits with "cross-neutralization." Either capacitive or link coupling may be used.

C-L — See section on tank-circuit design.
 C_N — Neutralizing condensers (see text).
 C₁ — 0.01 μ fd.
 C₂ — 0.001 μ fd. or larger.

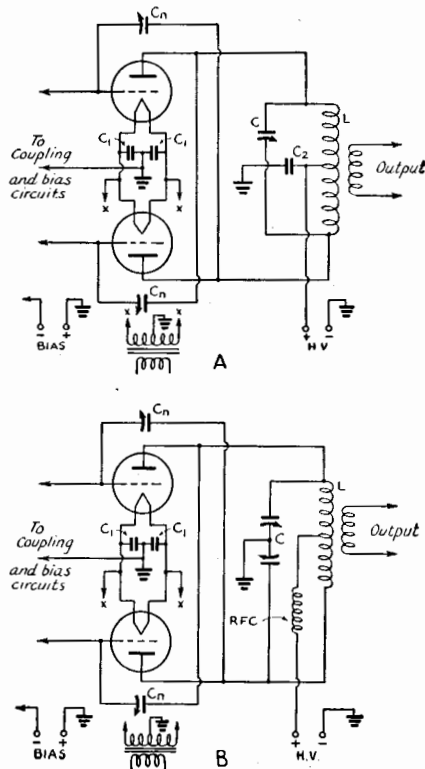

The Radio Amateur's Handbook

shaft are avoided. While an amplifier using the circuit of *B* may appear easier to drive compared to circuit *C* because of effects of regeneration when the tank circuit of *B* is tuned slightly off resonance, with proper neutralization, there should be no difference. With push-pull amplifiers, the circuit of Fig. 512-*B* is also preferred for the same reasons.

Neutralizing Condensers

In most cases the neutralizing voltage will be equal to the r.f. voltage between the plate and grid of the tube so that for perfect balance the capacity required in the neutralizing condenser theoretically will be equal to the grid-plate capacity of the tube being neutralized. If, in the circuits having tapped tank coils, the tap is more than half the total number of turns from the plate end of the coil, the required neutralizing capacity will increase approximately in proportion to the relative number of turns in the two sections of the coil.

For those tubes having grid and plate connections brought out through the bulb, a condenser having at about half-scale or less a capacity equal to the grid-plate capacity of the tube should be chosen. Where the grid and plate leads are brought through a common base, the capacity needed is greater because the tube socket and its associated wiring adds some capacity to the actual inter-element capacities. In such cases a slightly larger condenser should be used.

When two or more tubes are connected in parallel, the neutralizing capacity required will be in proportion to the number of tubes.

Tank-Circuit Design

So far as the plate efficiency of the tube itself is concerned, it does not matter how the load resistance is obtained; that is, the tube will work equally well into an actual resistor or into a tank circuit having any practicable constants so long as the resistance or impedance represented by the tank is the desired value. However, the distribution of the power output between the tank circuit and the load is affected by the inherent (unloaded) impedance of the tank circuit.

The impedance of the unloaded tank circuit at resonance is equal to L/CR , where L is the inductance, C the capacity, and R the effective resistance. The higher the ratio of the unloaded tank impedance to the optimum load impedance for the tube, the greater the proportion of power transferred to the load. The impedance of the tank alone should be at least ten times the optimum load impedance for high transfer efficiency. The unloaded tank impedance can be made high in two ways: by lowering the resistance through the construction of low-loss coils and by careful placement of parts, or by

raising the $L-C$ ratio. With practicable circuits, it is much easier to obtain high tank impedance by using a high $L-C$ ratio than by attempting to reduce the resistance, although every effort should of course be made to reduce losses.

Tank Impedance and Harmonic Output

When a high-impedance tank circuit is used, along with high grid bias and large values of excitation voltage, a large proportion of the power output is on harmonics of the fundamental frequency.

Should the circuit conditions be such that the harmonics cause circulating currents, there is a power loss which reduces the overall efficiency of the amplifier. In general, it will be found that any means employed in the output circuit to reduce harmonics also will result in an improvement in efficiency. A fair amount of flywheel effect also improves the stability of the amplifier and makes its tuning more satisfactory.

Because harmonic reduction calls for considerable flywheel effect, and consequently for a fairly large ratio of capacity to inductance, while high transfer efficiency requires high unloaded tank impedance (high $L-C$ ratio) in practice a compromise must be made between these two conflicting factors.

The amateur is chiefly concerned with the harmonic energy *radiated* because of the danger of interference to services operating in frequencies not assigned to amateurs. The radiation of harmonics is influenced by the type of antenna, its feed system, and the method of coupling between the antenna system and the final amplifier as well as the tank-circuit $L-C$ ratio and the excitation voltage so that it is obviously impossible to fix rigid rules for determining the value of capacity to be used in the tank circuit. Some sort of compromise is struck by basing tank-capacity calculations on a circuit "Q" of 12. Too much faith should not be placed in this figure, however, because it does not take into consideration wave shape upon which the harmonic content in the output chiefly depends. It represents a fair average, however, and if serious harmonic radiation is experienced, it can usually be reduced satisfactorily by proper adjustment of the antenna system and its coupling to the final amplifier. (See Chaps. 14 and 22.)

The capacity required to give a "Q" of 12 may be determined from the chart of Fig. 513. It is necessary only to know the plate voltage and plate current in ma. at which the amplifier is to operate. If a push-pull amplifier is used, or the tank coil tapped at the center or a split-stator condenser used for neutralizing, the *total* tank capacity may be reduced to one-quarter of the values given by the graph. This

Transmitter Design

means that the capacity of *each section* of a split-stator condenser will be one-half of the capacity shown by the graph. In determining the ratio of plate voltage to plate current, it should be remembered that the plate current of tubes in parallel or push-pull will be twice that of a single tube.

As an example, a beam tube, not requiring a balanced tank circuit for neutralization, operating at 1000 volts, 100 ma. (ratio 10/1) will require a tank capacity of 100 μmfd s. for 3.5 Mc. Two similar tubes in parallel (200 ma. — ratio 5/1) will require 200 μmfd s. Two similar tubes in push-pull (ratio 5/1) will require a total tank capacity of $\frac{200}{4}$ or 50 μmfd s. and if a split-stator condenser is used, the capacity should be 100 μmfd s. per section.

As a second example, a triode requiring a balanced tank circuit for neutralization op-

erating at 1000 volts, 100 ma. (ratio 10/1) will require a total capacity of 25 μmfd s. or 50 μmfd s. per section if a split-stator condenser is used. Two similar triodes in parallel (ratio 5/1) will require a total of 50 μmfd s. or 100 μmfd s. per section if a split-stator condenser is used. Two similar triodes in push-pull (ratio 5/1) will require the same capacities.

Reasonable departures from these figures would not affect the operation of the amplifier appreciably. An increase in capacity will cause some decrease in both transfer efficiency and harmonic output, while a decrease in the capacity will have the opposite effects. The increase in harmonic radiation with less capacity might be controlled by proper antenna coupling.

Tank-Condenser Voltage Rating

The peak voltage to be expected between the plates of a tank condenser depends upon the arrangement of the tank circuit as well as the d.c. plate voltage of the tube or tubes in use. Peak voltage may be determined from Fig. 514 which shows all of the commonly used tank-circuit arrangements. These estimates of voltage assume that the amplifier is loaded. Since a c.w. amplifier may be tuned up without load with a resulting rise in peak r.f. voltage, while a modulated amplifier should never be operated without load, the voltage for phone should be used in selecting a suitable tank condenser for either c.w. or phone unless tuning of the c.w. amplifier is done at reduced plate voltage. The figures include a reasonable factor of safety.

The spacing required to withstand any particular voltage will vary with the construction of the condenser. Most manufacturers specify peak voltage ratings for their condensers.

Determining Inductance

Once the required tank capacity and frequency are determined, the tank coil dimensions can be found. This may be done with the help of the L - C and inductance formulas in Chapter 20, or if standard coil forms are used, the charts of Figs. 516 and 517 will give the required number of turns directly. Using the chart which applies for the type of coil form or coil in question, read on the appropriate frequency curve the number of turns required for the tank capacity value already determined. The optimum tank LC ratio will result.

Fig. 516 is for coils wound on receiving-type forms having a diameter of $1\frac{1}{2}$ inches and ceramic forms having a diameter of $1\frac{3}{4}$ inches and winding length of 3 inches (National XR13). Such coils would be suitable for oscillator and buffer stages where the power to be carried is not over 50 watts. In all cases the number of turns given must be wound to fit

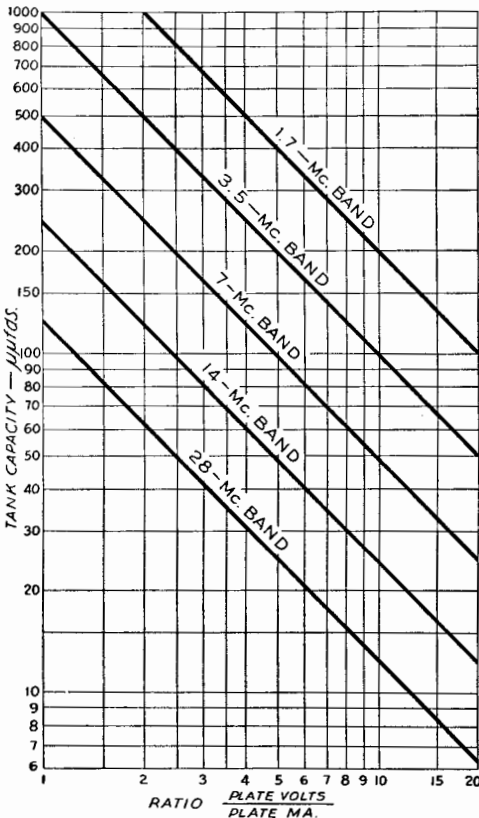

Fig. 513. — Chart showing tank-capacities required for "Q" of 12 with various ratios of plate voltage to plate current for various frequencies. In circuits F, G, H (Fig. 514), the capacities shown in the graph may be divided by four. In circuits C, D, E, I, J and K, the capacity of each section of the split-stator condenser may be one-half that shown by the graph. Values given by the graph should be used for circuits A and B.

The Radio Amateur's Handbook

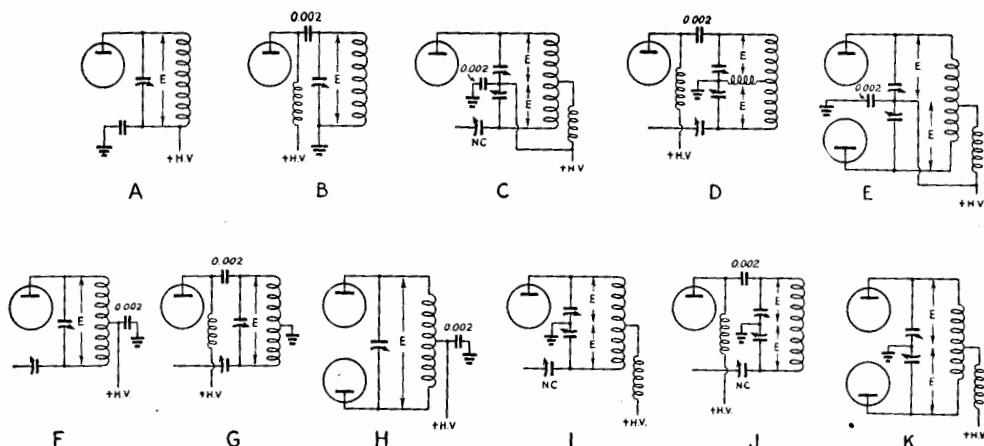

Fig. 514 — In circuits A, B, C, D and E, the peak voltage E will be equal to the d.c. plate voltage applied for c.w. or twice this value for phone. In circuits F, G, H, I, J and K, the peak voltage E will be twice the d.c. plate voltage for c.w. or 4 times the plate voltage for phone. Circuit is assumed to be loaded (see text). Tubes in parallel in any of the circuits will not affect the peak voltage. Circuits A, C, E, F, G and H require that the tank condenser be insulated from chassis or ground and be provided with a suitably insulated shaft coupling.

the length indicated; the turns should be spaced out evenly either by winding wire or string of suitable size between turns, or, in the case of those having few turns, by hand.

Fig. 517 gives data on coils wound on transmitting-type ceramic forms. Five popular types of forms are indicated. In the case of the smallest form, extra curves are given for double-spacing; that is, winding turns in alternate grooves. This is sometimes advisable in the case of 14- and 28-Mc. coils when only a few turns are required. In all other cases it is assumed that the specified number of turns is wound in the grooves without any additional spacing. Notes on coil construction will be found in Chapter 7.

Values and Voltage Ratings of By-Pass and Coupling Condensers

Plate- or screen-circuit by-pass condensers of 0.001 μfd . should be satisfactory for frequencies as low as 1.7 Mc. The capacity should not exceed 0.002 μfd . if connected across a modulated circuit. Cathode-resistor and filament by-passes in r.f. circuits should be not less than 0.01 μfd . Condensers should have

voltage ratings 25 to 50% greater than the d.c. voltage across them except in modulated circuits where the voltage rating should be two to three times the d.c. voltage. Blocking condensers may have capacities of 0.0005 μfd . or more with voltage ratings similar to those for by-pass condensers.

Coupling condensers should have voltage ratings equal to 50 to 100% more than the sum of the driver plate and amplifier biasing voltages. Values run from 0.002 to 0.0005 μfd . or less, depending upon requirements.

Excitation Requirements

The amount of driving power which will be required for any particular tube depends upon several factors. If the amplifier is heavily loaded, it will require more driving power to maintain the same plate efficiency of a more lightly loaded amplifier. If high plate-circuit efficiency is desired, greater driving power will be required than if the tube is operated at moderate plate efficiency. In general, greater driving power will be required as the frequency of operation increases because of higher circuit and tube losses. The required driving power will also vary depending upon whether or not the amplifier is to be modulated and, if so, upon the system of modulation used.

Beam-type tetrodes and pentodes require very little driving power (1 to 15 watts) while high-power triodes used in amateur transmitters may require a driver delivering as much as 100 watts or more.

Fig. 518 illustrates how the driving power required varies with plate-circuit efficiency. The curves are typical of triodes. Fixed values of load-resistance and grid bias are assumed. The

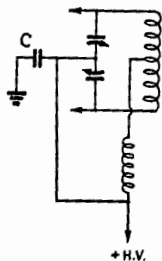
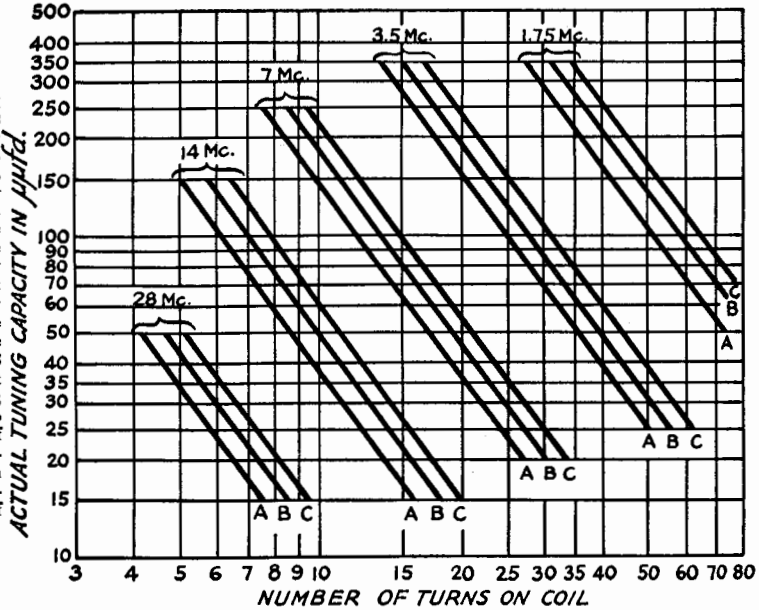

Fig. 515 — Use of blocking condenser permits smaller plate spacing with split-stator condensers. C should have a capacity of 0.001 to 0.002 μfd . and a voltage rating 3 to 4 times the d.c. voltage. Condenser control must be suitably insulated.

Transmitter Design

Fig. 516 — Coil-winding data for receiving-type forms, diameter $1\frac{1}{2}$ inches. Curve A — winding length, one inch; Curve B — winding length, $1\frac{1}{2}$ inches; Curve C — winding length, 2 inches. After determining the number of turns for the capacity and frequency band to be used, consult the wire table in Chapter Twenty to find the wire size which will fit in the space available. No. 18 wire is about the largest size that need be used; larger sizes are difficult to handle on this type of form. Curve C is also suitable for coils wound on $1\frac{3}{4}$ -inch diameter ceramic forms with 3 inches of winding length.



curves show that output and efficiency increase rapidly at first as the excitation is increased, then more slowly. The grid driving power curve rises rapidly beyond the maximum power amplification ratio, showing that a relatively large increase in excitation is necessary to produce a comparatively small increase in power output and efficiency once the optimum point — just to the right of the bend in

the output and efficiency curves — is passed. Assuming fixed plate voltage and load resistance, there is an optimum bias value which will give best results for every value of excitation voltage. The greater the excitation, the greater should be the bias. The power consumed in the amplifier grid circuit also is greater under these conditions. The grid power, furnished by the driver, is dissipated in the

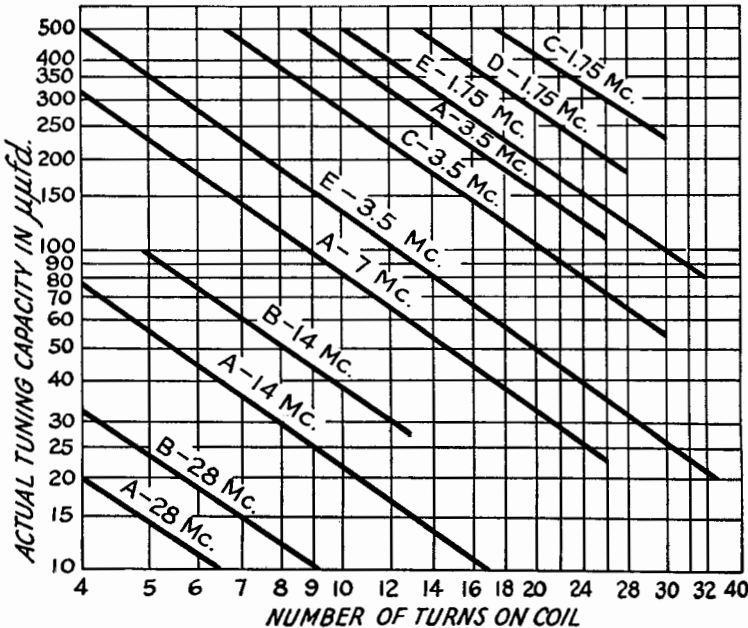

Fig. 517 — Coil-winding data for ceramic transmitting-type forms. Curve A — ceramic form $2\frac{1}{2}$ -inch effective diameter, 26 grooves, 7 per inch; Curve B — same as A, but with turns wound in alternate grooves; Curve C — ceramic form $2\frac{3}{4}$ -inch effective diameter, 32 grooves, 7.1 turns per inch, app.; Curve D — ceramic form 4-inch effective diameter, 28 grooves, 5.85 turns per inch, app.; Curve E — ceramic form 5-inch effective diameter, 26 grooves, 7 per inch. Coils may be wound with No. 12 or No. 14 wire.

The Radio Amateur's Handbook

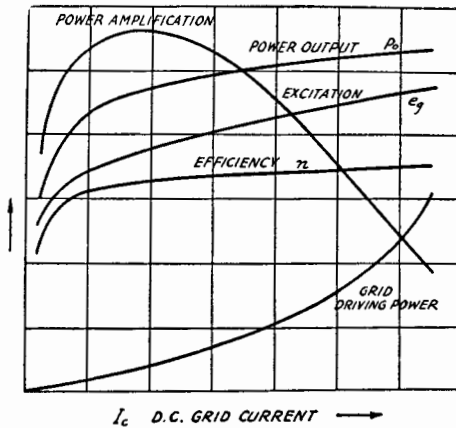

Fig. 518 — Effect of grid excitation on power amplifier performance.

grid-filament circuit of the tube, appearing as heat at the grid, in the bias supply, and also, particularly at the higher frequencies, as dielectric loss in the glass of the tube.

In the case of the beam tetrodes and pentodes, the power output may actually decrease after excitation exceeds a rather critical value. Since the driving power required by tubes of these types is quite small, care must be taken to avoid over-driving. (*Bib. 3*).

Measurement of Excitation

Measurement of the r.f. excitation voltage is difficult without special apparatus such as a vacuum-tube voltmeter, so it is customary to take the rectified current as a measure of the r.f. voltage and power supplied to the grid circuit of the amplifier. Under a given set of conditions, the higher the grid current the greater is the excitation voltage. However, a change in load resistance or a change in fixed bias or grid-leak resistance will cause a change in the value of d.c. grid current for the same excitation voltage, so that readings taken under different operating conditions are not comparable.

Efficiency and Output

The attainable plate efficiency is of great importance in determining the operating conditions for the amplifier. If the safe plate dissipation rating of the tube were the only consideration, it would be desirable to obtain the highest possible plate efficiency, since the power output would be limited solely by the efficiency. For example, a tube having a plate dissipation rating of 100 watts operating at a plate efficiency of 90% could handle an input of 1000 watts, giving 900 watts output, while the same tube at 70% efficiency could handle

an input of only 333 watts, giving an output of 233 watts. The plate dissipation — the difference between input and output — is the same in both cases, 100 watts.

There are other considerations, however, which limit the useful plate efficiency. Assuming that the total plate input is not to exceed the manufacturer's ratings for the tube, the difference between 70% and 90% efficiency is not so great. For instance, taking the same 100 watt tube and assuming that the 70% efficiency condition corresponds with the ratings, an efficiency of 90% would increase the output to only 300 watts (333 watts input). The additional 67 watts of output, an increase of about 27%, would require inordinately large driving power because, as shown by Fig. 518, the efficiency increases very slowly beyond the optimum point, while the reverse is true of the driving power required.

A second factor which limits the usable efficiency is the fact that high values of efficiency are attained only through the use of high values of load resistance, which in turn requires the use of very high plate voltage. Not all tubes are suited to operation at plate voltages much above their normal ratings, while from an economic standpoint a high-voltage power supply may represent greater cost than the installation of a second tube operating at lower voltage to give the same order of total power output, but at lower plate efficiency.

Grid Bias

For efficient tube operation, it is essential that plate current be drawn in pulses which occupy only a small part of the complete r.f. cycle, and that the peak value of the plate current pulse be several times the average d.c. plate current value as read by a milliammeter. This requirement is met by using grid bias considerably larger than that necessary to cut off plate current (without excitation) at the operating d.c. plate voltage. It is customary to operate with grid bias equal to twice the cut-off value, and where higher than ordinary efficiency is to be obtained, with even larger values. This method of operation requires correspondingly large grid excitation voltage and power.

Maximum plate efficiency will result when high bias, large excitation power, and a high value of load resistance or impedance are used. If the excitation is low, both grid bias and plate load impedance must be reduced for maximum output, although the efficiency will be comparatively low. The greatest power amplification ratio and maximum output with small excitation usually result when the bias is set at the cut-off value. Under these conditions the plate efficiency seldom exceeds fifty

Transmitter Design

to sixty per cent. Plate efficiencies of 75% are usual when the bias is twice cut-off and the tube is adequately excited.

Amplifier Loading

The plate tank circuit, together with the apparatus coupled to it (an antenna or following amplifier stage) constitutes the plate load for the tube. When the tank is tuned to resonance with the exciting frequency, it is practically equivalent to resistance only, so that it is customary to refer to the load circuit as a resistance or impedance. The value of equivalent resistance represented by the tank circuit is dependent upon the ratio of inductance to capacity, upon the inherent r.f. resistance of the coil and condenser making up the tank, and upon the effective resistance coupled into the tank from the external circuit to which it is supplying power. The tank resistance or impedance decreases as the coupling to the external circuit is increased, and also decreases as the ratio of inductance to capacity is decreased.

The value of load resistance or impedance which will give optimum power output and efficiency depends upon the grid bias and excitation voltage.

Output Coupling

Coupling systems for use between amplifier stages have already been discussed. Many arrangements have been devised for coupling the output of an amplifier to the antenna system. The system most suitable for the purpose will depend chiefly upon the details and characteristics of the antenna system and will be taken up in detail in the section on antennas. Either capacitive or inductive forms of coupling may be used, but the latter are preferred because of their discrimination against the transference of energy at harmonic frequencies. The antenna itself (the radiating portion of the antenna system) is rarely coupled directly to the output of the amplifier except at the lower frequencies. At the higher frequencies, a transmission line of some sort is used between the transmitter output circuit and the antenna.

Part of the transmission line or antenna may be in the form of a coil coupled to the output-amplifier tank circuit. A low-impedance line similar to that used in interstage link coupling may be used to couple the amplifier tank circuit to a separate tank circuit which, in turn, is connected to the antenna or transmission line. Sometimes a low-pass filter is used to couple the output tank circuit to the antenna system.

● FREQUENCY MULTIPLICATION

Frequency multipliers are universally used in amateur transmitters so that output can be

secured on higher-frequency bands than that for which the crystal is cut. Although crystals are available for fundamental operation on frequencies as high as the 28-Mc. band, the relatively lower cost of the 1.75-, 3.5- and 7-Mc. crystals favors the use of these crystal frequencies, with frequency multipliers for the other bands. In addition, usually it is more convenient, as well as less expensive, in multi-band transmitters to have all crystals ground for one low-frequency band.

The frequency multiplier or harmonic generator is a tube having its plate tank circuit tuned to a harmonic of the frequency applied to its grid. Otherwise, the circuit is the same as that of an ordinary power amplifier. Its effectiveness as a generator of harmonics depends upon the tube characteristics and the way in which it is operated. Since the amateur bands are in even-harmonic relation, the harmonics of chief interest are the second, fourth, eighth, and so on. In practice, the frequency multiplier is inefficient on harmonics

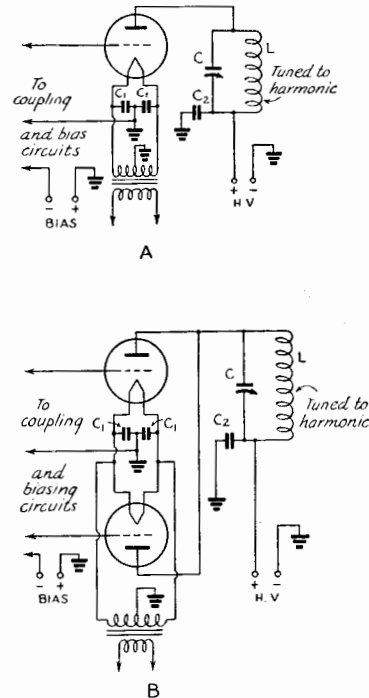

Fig. 519 — Frequency-multiplying circuits. A shows circuit for single or parallel tubes. The arrangement at B is known as the "push-push" doubler circuit. Either capacitive or link coupling may be used.

C-L.—The tank circuit with frequency multipliers should have low values of C. C should be about 50 $\mu\text{fd.}$ for the lower frequencies and about 25 $\mu\text{fd.}$ at 14 Mc. and higher frequencies. Coil dimensions may be selected from the graphs of Figs. 516 and 517. C₁—0.01 $\mu\text{fd.}$; C₂—0.001 $\mu\text{fd.}$ or larger.

The Radio Amateur's Handbook

higher than the second, so the second-harmonic multiplier or *doubler* is in most common use.

Since the input and output circuits of a doubler are not tuned to the same frequency there is no tendency toward self-oscillation, even with unneutralized triodes. Neutralization of doublers is quite common, however, because the same stage often is used as a straight amplifier; in addition, neutralization may actually improve the efficiency.

Doubler Operating Conditions

To obtain maximum output and efficiency from the doubler it is necessary to use high negative grid bias on the tube — considerably more than double cut-off — and excite it with a correspondingly high radio-frequency voltage. This accentuates harmonic generation in the plate circuit. A low-*C* tank in the plate circuit is also desirable. In general, a tube having a relatively large amplification factor is to be preferred as a doubler because relatively low bias and excitation voltage will give high distortion. Pentodes, beam tetrodes and high- μ triodes all make good doublers.

The efficiency and output of a doubler can be increased by feeding some of the energy in the plate circuit back to the grid to cause regeneration, provided the process is not carried so far that the tube breaks into self-oscillation. One of the most satisfactory ways of introducing regeneration is through neutralizing the frequency multiplier by one of the methods in which the neutralizing voltage is fed from the plate circuit to the grid. The single-tube circuits of Fig. 511 are examples. When the tube is properly neutralized it cannot oscillate, yet the feedback at the harmonic frequency is sufficient to increase the output and efficiency of the doubler to a worth-while extent.

The grid leak for a doubler may in general have a resistance from two to five times that recommended for the tube as a straight amplifier. The driving power required for good doubling efficiency will be two or three times greater than that necessary for efficient straight amplification.

Push-pull amplifiers cannot be used as doublers because the second and other even harmonics are cancelled in the output. They can be used as triplers, however, the output circuit being tuned to the third harmonic. They are not very often used in this way because the frequency relations of the amateur bands are such that even-harmonic output is necessary.

Doubler Circuits

The simple triode doubler circuit is shown in Fig. 519-A. Screen-grid or pentode doubler circuits are exactly the same as the straight amplifier diagrams given in Fig. 510. The plate tank is simply tuned to the second harmonic

instead of the fundamental frequency. Neutralized circuits such as those in Fig. 511 also can be used.

Special circuits for frequency doubling also have been employed; one which is often used is shown in Fig. 519-B. In this circuit two tubes are used; the excitation is fed to the grids in push-pull while the plates of the tubes are connected in parallel. Thus the tubes work alternately, and the output circuit receives two impulses for each r.f. cycle at the grids, resulting in all second-harmonic output. This circuit gives quite good efficiency, although requiring two tubes. It is often called a "push-push" doubler. In low-power stages, twin triodes such as the 53 and 6A6 can be used as single-tube push-push doublers. The high amplification factors of these two types make them especially suitable for this purpose.

A circuit of this type is not suitable in cases where a stage is to be used both as a straight amplifier and a doubler, since it will not operate efficiently as a straight amplifier.

Planning a Transmitter

Essentially, a transmitter is simply an oscillator followed by a series of amplifiers to raise the power of output level to the desired figure. Some of the amplifiers will be frequency multipliers, if output is desired on a frequency higher than that on which the oscillator operates. The problem of designing a transmitter, therefore, is that of deciding upon the number of stages to use, the kind of tubes to use, and upon choosing correct operating conditions.

Transmitting Tubes

A great many types of transmitting tubes are available for amateur work. They are listed in the tube tables in Chapter 20, together with sets of typical operating conditions for the various types. When a tube capable of the desired power output is decided upon, the next step in laying out the transmitter is to select an oscillator circuit and to decide upon the band in which the crystals are to operate. The features of the various oscillator circuits have been treated earlier in the chapter. We then have the beginning and the end of the transmitter, and it becomes necessary to choose intermediate stages which will be sure to deliver enough power to the grid of the final tube to excite it properly. Reference to the tube tables (Chapter 20) will be of assistance.

In laying out any transmitter it is decidedly good practice to be conservative throughout. Be sure to provide more than just enough excitation for each stage; the driving-power figures given in the tube tables, for instance, do not include an allowance for losses in the grid-tank circuit or in coupling between the driver and amplifier. Likewise, the power output fig-

Transmitter Design

ures are total output, and do not include tank losses. In every case the driver should be capable of supplying two to three times the driving power specified in the tube tables.

For straight amplifier exciting stages, it is best not to figure on more than about 60% overall efficiency, to include an allowance for losses in tank circuits and coupling devices. Doublers work at lower efficiency; 40% is a fairly conservative figure. Remember that a doubler requires high bias and hence more excitation than a straight amplifier, probably two or three times as much. With these figures in mind, it is not difficult to select a tube combination which will be sure to work.

● EXCITER UNITS

When a transmitter is to work on several bands, it becomes necessary to supply the same amount of excitation power to the amplifier over a wide range of frequencies. There are several ways of meeting this problem, one of which is to use a series of small tubes as oscillators and doublers, taking output from the tube working on the desired frequency. The power level is then built up by straight amplifiers. Other methods employ only a few tubes but use special circuits such as the Tri-tet or grid-plate oscillator which can give output on harmonics as well as the fundamental crystal frequency. A unit designed for giving approximately the same output for excitation purposes on several bands is called an "exciter unit."

The output of an exciter unit may vary from a few watts to a hundred or so, depending upon the design. Usually the exciter covers at least three bands, although many can operate in five. It is evident that the exciter also can be used as a multi-band transmitter of low or moderate power output.

Exciter units may utilize plug-in coils for band changing or may achieve the same end by a switching arrangement. Often a combination of both is used. A good exciter is the first requisite of a multi-band transmitter.

● BAND-SWITCHING

In the exciter units, where efficiency may often be of less importance than operating convenience, some of the circuits may be designed

to cover two bands with a single coil by the use of a large tuning condenser. This method is not suitable for higher-power amplifiers because it is impossible to provide optimum *C* for the tank circuit at both extremes of the range.

Several systems have been worked out whereby an inductance change instead of a capacity change is employed in shifting operation from one band to another. In one system, switches are employed to short-circuit turns of a low-frequency coil to render it suitable for higher frequencies. This method is very convenient and involves no appreciable losses in covering three bands. In a second method, separate appropriate tank coils are provided for each band while a system of switches is used to switch connections between the tank condenser and one or another of the coils. A third method, used in exciters, employs a system of switches to cut frequency-doubling stages in or out of the circuit as desired.

Ganged Tuning

The tuning controls of a transmitter may be ganged as easily as those of a receiver and the same principles apply. One of the most satisfactory systems employs the tapped-coil band-spread and tracking system. A self-controlled oscillator is required for complete frequency coverage, of course (Bib. 4).

Metering

In order to adjust a transmitter for proper operation, certain meters are almost indispensable. The most useful of all is the d.c. milliammeter for reading plate current in each stage. An additional d.c. milliammeter is highly desirable for measuring the rectified grid current in each stage. A low-voltage a.c. meter for checking filament voltages and a high voltage d.c. meter for checking plate voltages need not be built into the transmitter, but will be found extremely useful around the amateur station. A thermo-ammeter for reading r.f. antenna or feeder current will help in checking the adjustment of the transmitter, although it is not strictly necessary. Information on meter applications will be found in Chapter 13.

Bibliography

- ¹ "An Answer to the E.C.O. Problem," Perrine, *QST*, Sept. 1939. "Electron-Coupled vs. Crystal Transmitter Control," *Mix*, *QST*, April 1936.
- ² "A Practical Survey of Pentode and Beam Tube Crystal Oscillators," Lamb, *QST*, April 1937.
- ³ "The Operation of R.F. Power Amplifiers," Robinson, Part I, *QST*, Feb. 1934; Part II, April 1934.
- ⁴ "Gang Tuning for the Multi-Stage Transmitter," *Mix*, *QST*, June 1938.
- ⁵ "One Crystal—Two Tubes—Five Bands," Ferrill, *QST*, March 1939.

Modulation

Principles — Methods of Modulation — Class-B Modulators — Microphones and Speech Amplifiers — Design Data

THE steady radio-frequency power generated by transmitting circuits such as those shown in the preceding chapter cannot alone result in the transmission of an intelligible message to a receiving point. It serves only as a "carrier" for the message; the intelligence is conveyed by **modulation** (a change) of the carrier.

The simplest way to modulate the carrier is to turn it on and shut it off, and when this is done according to the dot-and-dash characters of the telegraph code we have what is called continuous-wave telegraph transmission. Although simple in principle, in actual practice this type of modulation — **keying** — must conform to certain requirements. These, and the actual circuits used for keying, will be considered in a later chapter. We shall discuss here the more complicated form of modulation necessary for radiotelephone transmission.

Audio Frequencies

Sounds are caused by vibrations of air particles. The pitch of the sound depends upon the rate of vibration; the more rapid the vibration the higher the pitch. Most sounds consist of complex combinations of vibrations of differing rates or frequencies; the human voice, for instance, generates frequencies from about 100 per second to several thousand per second. Words are formed by combining various frequencies in a variety of ways. The problem of transmitting speech by radio is therefore one of varying the r.f. carrier in a way which corresponds to the air-particle vibrations. The first step in doing this is to change the sound vibrations into alternating electrical currents of the same frequency and relative intensity; these currents may then be amplified and used to modulate the normally-steady r.f. output of the transmitter.

Principle of the Microphone

The device which converts sound energy into electrical energy is called the microphone. There are several types of microphones, but one example will show the general principle of operation. In Fig. 601, the microphone consists of a metal diaphragm placed against an insulating cup containing loosely-packed car-

bon granules (**microphone button**). Current from a battery flows through the granules, the diaphragm being one connection and the metal back-plate the other. The primary of a transformer is connected in series with the battery and microphone. Air vibrations cause a similar vibration of the diaphragm, and as the diaphragm vibrates its pressure on the granules alternately increases and decreases. This causes a corresponding increase and decrease of current flow through the circuit, since the pressure changes the resistance of the mass of granules. The change in current flowing through the transformer primary causes an alternating voltage, of corresponding frequency and intensity, to be set up in the transformer secondary. The audio-frequency voltage thus generated may be amplified by a vacuum tube connected to the transformer. The audio-frequency power may be built up to any desired level by successive stages of amplification. The amount of power needed to modulate the r.f. carrier depends upon the modulation system employed.

Modulation

One way of modulating the carrier is by changing its amplitude, or intensity, in accordance with the a.f. voltage obtained from the microphone. This method, known as amplitude modulation, is used in all amateur transmitters working below 58.5 megacycles. It is also possible to vary the frequency of the carrier (frequency modulation) while leaving its amplitude fixed. With this method the band

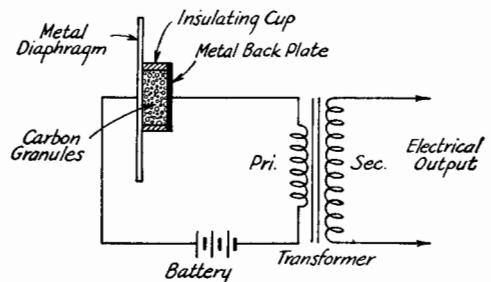

Fig. 601 — Construction and connections of a single-button microphone and its transformer.

Modulation

of frequencies occupied by one transmitter is greater than in the case of amplitude modulation, hence fewer transmitters can work without interference. The amateur regulations prohibit frequency modulation below 58.5 Mc., and transmitters must be designed to prevent its occurring accidentally in connection with amplitude modulation. In this chapter, only the amplitude modulation system is considered.

Amplitude Modulation

Since the audible output at the receiver depends entirely upon the amount of variation — termed **depth of modulation** — in the carrier wave and not upon the strength of the carrier alone, it is desirable to obtain the largest permissible variations in the carrier wave. This condition is reached when the amplitude during modulation is at times reduced to zero and at other times increased to twice its unmodulated value. Such a wave is said to be **fully modulated**, or **100% modulated**. Any desired degree of modulation can be expressed as a percentage, using the unmodulated carrier as a base. Fig. 602 shows at A an unmodulated carrier wave; at B the same wave modulated 50%, and at C the wave with 100% modulation, using a single-tone (sine-wave) modulation,

ing signal. The outline of the modulated r.f. wave is called the **modulation envelope**.

The percentage modulation can be found by dividing either Y or Z by X and multiplying the result by 100. If the modulating signal is not symmetrical, the larger of the two (Y or Z) should be used.

The amplitude values correspond to current or voltage, so that the drawings may be taken to represent instantaneous values of either. Since power varies as the square of either the current or voltage, so long as the resistance in the circuit is unchanged, therefore at the peak of the modulation up-swing the instantaneous power in the wave of Fig. 602-C is four times the unmodulated carrier power. At the peak of the down-swing the power is zero since the amplitude is zero. With a sine-wave modulating signal, the *average* power in a 100%-modulated wave is one and one-half times the unmodulated carrier power. The power output of the transmitter must increase 50%, therefore, with 100% modulation. This is a very important consideration, since it means that provision must be made to supply the additional power during modulation.

● SIDE BANDS

The combining of the audio frequency with the r.f. carrier as just described is essentially a heterodyne process and therefore gives rise to beat frequencies equal to the sum and difference of the a.f. and r.f. frequencies involved. Therefore, for each audio frequency appearing in the modulation two new radio frequencies appear, one equal to the carrier frequency plus the audio frequency, the other equal to the carrier minus the audio frequency. These new frequencies are called **side frequencies**, since they appear on each side of the carrier, and the groups of side frequencies representing a band or group of modulation frequencies are called **side bands**. The side bands must be transmitted, hence a modulated signal occupies a group of radio frequencies, or **channel**, rather than a single frequency as in the case of the unmodulated carrier. The **channel width** is twice the highest modulation frequency. To accommodate the largest number of transmitters in a given part of the r.f. spectrum it is apparent that the channel width should be as small as possible, but on the other hand it is necessary, for speech of reasonably good quality, to use modulating frequencies up to about 3000 or 4000 cycles. This calls for a channel width of 6 to 8 kc.

Spurious Side Bands

Besides the normal side bands just described, unwanted side bands may be generated by the transmitter. These usually lie outside the normally-required channel width, and hence

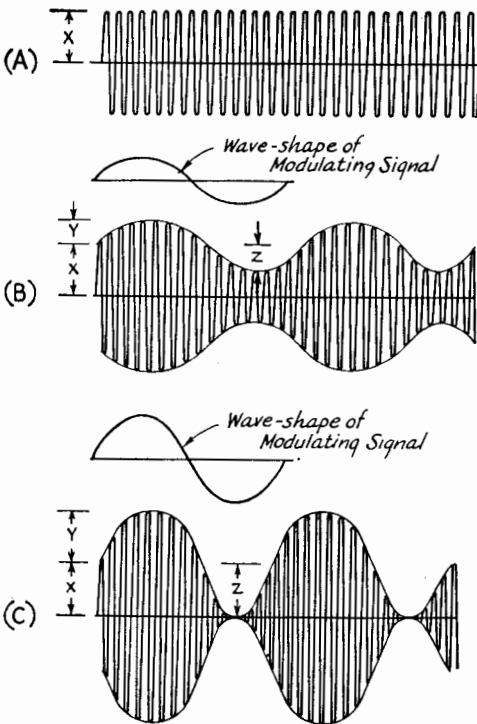

Fig. 602 — Graphical representation of (A) unmodulated carrier wave, (B) wave modulated 50%, (C) wave modulated 100%.

The Radio Amateur's Handbook

cause the actual channel to be wider without increasing the useful modulation. By increasing the channel width these spurious side bands cause unnecessary interference to other transmitters. The quality of transmission is also adversely affected when spurious side bands are generated.

The chief causes of spurious side bands are harmonic distortion in the audio system, overmodulation, frequency modulation, and lack of linearity in the modulated r.f. system.

Harmonic Distortion

As explained in Chapter 3, distortion in an amplifier tube can be resolved into the introduction of new frequencies in the output which were not present in the signal applied to the grid. Since these new frequencies are integral multiples of the original frequency, they may cause widening of the side bands. For example, an original modulating signal of 3000 cycles may, when distorted, have harmonics at 6000, 9000, and 12,000 cycles. Thus a required channel of 6 kc. may actually turn out to be 24 kc. because of spurious side bands. Minimum harmonic distortion in the a.f. amplifier is necessary to prevent excessive channel width.

Overmodulation

If the carrier is modulated more than 100%, a condition such as is shown in Fig. 603 occurs. Not only does the peak amplitude exceed twice the carrier amplitude, but there may actually be a considerable period during which the output is entirely cut off. The modulated wave is therefore distorted, with the result that harmonic distortion, with consequently wider side bands, occurs. The carrier should never be modulated more than 100%.

Frequency Modulation

If modulating the amplitude of the carrier also causes a change in the carrier frequency, the channel occupied by the signal wobbles back and forth with the modulation. Not only does this alone widen the effective channel, but because of the varying frequency new beats are generated which create an even more undesirable broadening of the signal. It is essential, therefore, that the carrier frequency be entirely unaffected by the application of modulation. In practice, this is accomplished by applying the modulation to an r.f. amplifier stage which is isolated from the frequency-controlling oscillator by a buffer amplifier. Amplitude modulation of an oscillator is almost always accompanied by frequency modulation.

Linearity

Up to the limit of 100% modulation, the amplitude of the carrier should follow faith-

fully the amplitude variations of the modulating signal. When the modulated r.f. amplifier is incapable of meeting this condition it is said to be **non-linear**. A non-linear modulated

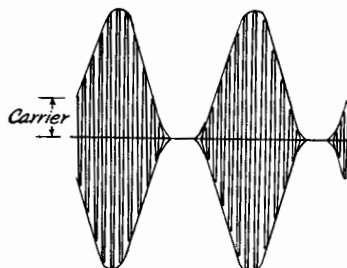
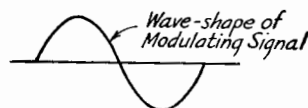

Fig. 603 — An overmodulated wave.

amplifier causes distortion of the modulation envelope and hence the generation of harmonics which in turn widen the channel. The amplifier may not, for instance, be capable of quadrupling its power output at the peak of 100% modulation. The **modulation capability** of the transmitter is the maximum percentage of modulation that is possible without objectionable distortion (i.e., without generating spurious side bands). The maximum attainable capability is, of course, 100%. The modulation capability should be as high as possible so that the most effective signal can be transmitted for a given carrier power.

Power in Speech Waves

The complex waveform of a speech sound translated into alternating current does not contain as much power, on the average, as there is in a pure tone or sine wave of the same peak amplitude. That is, with speech waveforms the ratio of peak to average amplitude is higher than in the sine wave. For this reason, the previous statement that the power output of the transmitter increases 50% with 100% modulation, while true for tone modulation, is not true for speech. On the average, speech waveforms will contain only about half as much power as a sine wave, both having the same peak amplitude. The average power output of the transmitter therefore increases only about 25% with 100% speech modulation. However, the *instantaneous* power output must quadruple on the peak of 100% modulation regardless of the modulating waveform. Therefore the peak capacity of the transmitter

Modulation

must be the same for any type of modulating signal.

● PRACTICAL METHODS OF MODULATION

The most widely used type of amplitude modulation system is that in which the modulating signal is applied in the plate circuit of a radio-frequency power amplifier (**plate modulation**). In a second type the audio signal is applied to the control-grid circuit (**grid-bias modulation**). A third system involves variation of both plate voltage and grid bias and is called **cathode modulation**. A fourth method varies the suppressor-grid voltage of a pentode-type power tube (**suppressor-grid modulation**).

Transformer-Coupled Plate Modulation

In Fig. 604 is shown the most widely-used system of plate modulation. A balanced (push-pull Class-A, Class-AB or Class-B) modulator is transformer-coupled to the plate circuit of

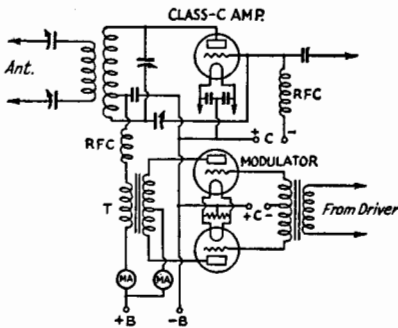

Fig. 604 — Transformer-coupled plate modulation.

the modulated r.f. amplifier. The audio-frequency power generated in the modulator plate circuit is combined with the d.c. power in the modulated-amplifier plate circuit by transfer through the coupling transformer, *T*. For 100% modulation the audio-frequency output of the modulator and the turns ratio of the coupling transformer must be such that the voltage at the plate of the modulated amplifier varies between zero and twice the d.c. operating plate voltage, thus causing corresponding variations in the amplitude of the r.f. output.

As previously indicated, the average power output of the modulated stage must increase 50% with 100% modulation, and the additional power is furnished by the modulator; that is, the modulator must supply audio power equal to 50% of the d.c. plate input to the modulated r.f. stage. For example, if the d.c. plate power input to the r.f. stage is 100 watts, the sine-wave audio power output of the modulator must be 50 watts.

The modulated r.f. amplifier must operate

Class-C for the modulation characteristic to be linear. The transformer turns ratio will depend upon the rated load resistance of the modulator tubes and the **modulating impedance** of the Class-C stage. The modulating impedance is equal to

$$\frac{E_b}{I_p} \times 1000$$

where E_b is the d.c. plate voltage and I_p the d.c. plate current in milliamperes, both measured without modulation.

The plate efficiency of the Class-C plate-modulated amplifier is practically constant with or without modulation. Efficiency values range between 60% and 80%, depending upon the frequency and the operating conditions. The **linearity** depends upon having sufficient grid excitation, proper bias, and adjustment of circuit constants to the proper values, as described in Chapter 5.

Plate Modulation of Screen-Grid Amplifiers

Screen-grid tubes of the pentode or beam tetrode type can be used as Class-C plate-modulated amplifiers provided the modulation is applied to both the plate and screen grid. The method of feeding the screen grid with the necessary d.c. and modulation voltage is shown in Fig. 605. The dropping resistor, *R*, should be

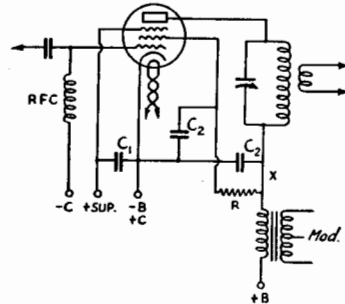

Fig. 605 — Plate and screen modulation of a pentode Class-C r.f. amplifier.

of the proper value to apply normal d.c. voltage to the screen under steady carrier conditions. Its value can be calculated by taking the difference between plate and screen voltages and dividing it by the rated screen current.

The modulating impedance is found by dividing the d.c. plate voltage by the sum of the plate and screen currents. The plate voltage multiplied by the sum of the two currents is the power input figure which is used as the basis for determining the audio power required from the modulator.

Choke-Coupled Plate Modulation

In Fig. 606 is shown the circuit of the Heising or constant-current system of plate

The Radio Amateur's Handbook

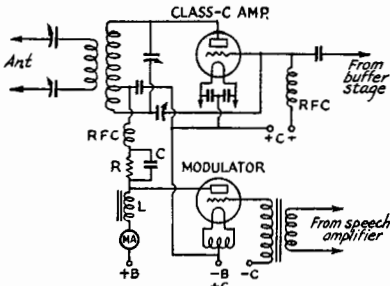

Fig. 606 — Choke-coupled or Heising plate modulation.

modulation. The plate power for the modulator tube and modulated amplifier is furnished from a common source through the modulation choke, L , which has high impedance for audio frequencies. The modulator operates as a power amplifier with the plate circuit of the r.f. amplifier as its load, the audio output of the modulator being superimposed on the d.c. power supplied to the amplifier. For 100% modulation the audio voltage applied to the r.f. amplifier plate circuit across the choke, L , must have a peak value equal to the d.c. voltage on the modulated amplifier. To obtain this without distortion, the r.f. amplifier must be operated at a d.c. plate voltage less than the modulator plate voltage, the extent of the voltage difference being determined by the type of modulator tube used. The necessary drop in voltage is provided by the resistor R , which is by-passed for audio frequencies by the condenser C .

This type of modulation is rarely used by amateurs except in very low-power portable sets, because a single-tube Class-A modulator is required. The output of a Class-A modulator is very low compared to that obtainable from a pair of tubes of the same size operated Class-B, hence only a small amount of r.f. power can be modulated.

Grid-Bias Modulation

Fig. 607 is the diagram of a typical arrangement for grid-bias modulation. In this system,

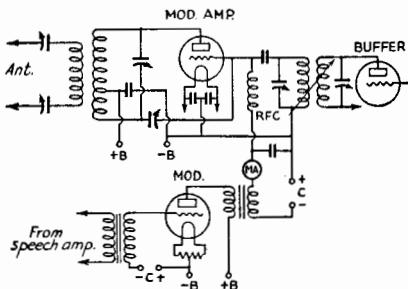

Fig. 607 — Grid-bias modulation of a Class-C amplifier.

the secondary of an audio-frequency output transformer, the primary of which is connected in the plate circuit of the modulator tube, is connected in series with the grid-bias supply for the modulated amplifier. The audio voltage thus introduced varies the grid bias and thus the power output of the r.f. stage, when suitable operating conditions are chosen. The r.f. stage is operated as a Class-C amplifier, with the d.c. grid bias considerably beyond cut-off.

In this system the plate voltage is constant, and the increase in power output with modulation is obtained by making the plate current and plate efficiency vary with the modulating signal. For 100% modulation, both plate current and efficiency must, at the peak of the modulation up-swing, be twice their carrier values so that the peak power will be four times the carrier power. Since the peak effi-

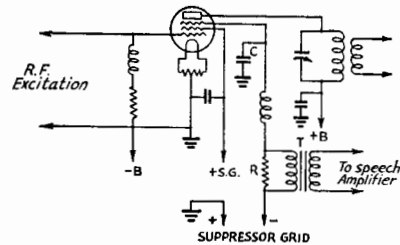

Fig. 608 — Suppressor-grid modulation of a pentode r.f. amplifier.

ciency in practicable circuits is of the order of 70% to 80%, the carrier efficiency ordinarily cannot exceed about 35% to 40%. For a given size of r.f. tube the carrier output is about one-fourth the carrier obtainable from the same tube plate-modulated. The audio power required from the modulator is quite small, and a Class-A modulator capable of 2 to 5 watts audio output is adequate for most transmitters. The grid bias, r.f. excitation, plate loading and audio voltage in series with the grid must be adjusted to give a linear modulation characteristic. The method of adjustment is covered in Chapter 16.

Suppressor Modulation

The circuit arrangement for suppressor-grid modulation of a pentode tube is shown in Fig. 608. The operating principles are the same as for grid-bias modulation. However, the r.f. excitation and modulating signals are applied to separate grids, which gives the system a simpler operating technique, since best adjustment for proper excitation requirements and proper modulating circuit requirements are more or less independent. The carrier plate efficiency is approximately the same as for grid-bias modulation, and the modulator power

Modulation

requirements are similarly small. With tubes having suitable suppressor-grid characteristics, linear modulation up to practically 100% can be obtained with negligible distortion.

Cathode Modulation

The fundamental circuit for cathode or "center-tap" modulation is shown in Fig. 609. This type of modulation is a combination of the plate- and grid-bias methods, and permits a carrier efficiency midway between the two. The audio power is introduced in the cathode circuit, and both grid bias and plate voltage vary during modulation.

Because part of the modulation is by the grid-bias method, the plate efficiency of the modulated amplifier must vary during modulation. The carrier efficiency therefore must be lower than the efficiency at the modulation peak. The reduction in carrier efficiency depends upon the proportion of grid modulation to plate modulation; the higher the percentage of plate modulation the higher the permissible carrier efficiency, and vice versa. The audio power required from the modulator also varies with the percentage of plate modulation, being greater as this percentage is increased.

The way in which the various quantities vary is illustrated by the curves of Fig. 609-A. In these curves, the performance of the cathode-modulated r.f. amplifier is plotted in terms of the tube ratings for plate-modulated telephony, with the percentage of plate modulation as a base. As the percentage of plate modulation is decreased, it is assumed that the grid-bias modulation is increased to make the overall percentage of modulation reach 100%. The limiting condition, 100% plate modulation and no grid-bias modulation, is

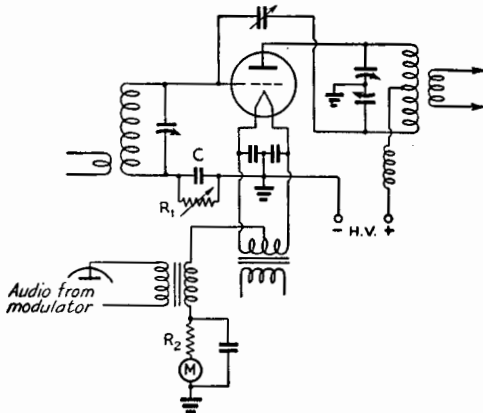

Fig. 609 — Cathode modulation of a Class-C triode amplifier. R_1 , grid leak; C , audio by-pass; R_2 , cathode-bias resistor for initial bias, also by-passed for audio frequencies.

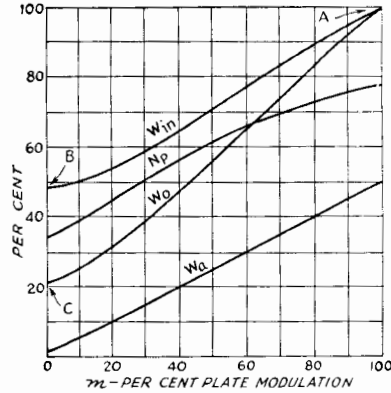

Fig. 609-A — Cathode-modulation performance curves, in terms of percentage of plate modulation against per cent of Class-C telephony tube ratings.

- W_{in} — D.c. plate input watts in per cent of plate-modulation rating.
- W_o — Carrier output watts in per cent of plate-modulation rating (based on plate efficiency of 77.5%).
- W_a — Audio power in per cent of d.e. watts input.
- N_p — Plate efficiency in per cent.

at the right; pure grid-bias modulation is represented by the left-hand ordinate.

As an example, assume that 40% plate modulation is to be used. Then the modulated r.f. amplifier must be adjusted for a carrier plate efficiency of 56%, the permissible plate input will be 65% of the ratings of the same tube with pure plate modulation, the power output will be 48% of the rated output of the tube with plate modulation, and the audio power required from the modulator will be 20% of the d.c. input to the modulated amplifier.

The modulating impedance of a cathode-modulated amplifier is approximately equal to

$$m \frac{E_b}{I_b}$$

where m is the percentage of modulation expressed as a decimal, E_b is the plate voltage, and I_b the plate current of the modulated r.f. amplifier. This figure for the modulating impedance is used in exactly the same way as the corresponding figure for pure plate modulation in determining the proper modulator operating conditions, as outlined in the following section.

R.f. excitation requirements for the cathode-modulated amplifier are midway between those for plate modulation and grid-bias modulation. More excitation is required as the percentage of plate modulation is increased. Grid bias should be considerably beyond cut-off; grid-leak bias is permissible if the excitation is great enough to meet this requirement. The grid leak should be across the grid condenser, as shown, to avoid loading the modulator, and should be by-passed for audio frequencies. The percentage of grid modulation

The Radio Amateur's Handbook

TABLE I—RESISTANCE-COUPLED AMPLIFIER DATA

Data are given for a plate-supply of 300 volts; departures of as much as 50% from this supply voltage will not materially change the operating conditions or the voltage gain, but the output voltage will be in proportion to the new voltage. Voltage gain is measured at 400 cycles; condenser values given are based on 100-cycle cut-off. For increased low-frequency response, all condensers may be made larger than specified (cut-off frequency in inverse proportion to condenser values provided all are changed in the same proportion). A variation of 10% in the values given has negligible effect on the performance.

High-frequency cut-off with pentodes is approximately 20,000 cycles with a plate resistor of 0.1 megohm, 10,000 cycles with 0.25 megohm, and 5000 cycles with 0.5 megohm. With triode amplifiers, the high-frequency cut-off is well above the audio range.

	Plate Resistor Megohms	Next-Stage Grid Resistor Megohms	Screen Resistor Megohms	Cathode Resistor Ohms	Screen By-pass μ d.	Cathode By-pass μ d.	Blocking Condenser μ d.	Output Volts (Peak) ²	Voltage Gain ³
6A6, 6N7 53	0.1	0.1	—	1150 ¹	—	—	0.03	60	20
		0.25	—	1500 ¹	—	—	0.015	83	22
		0.5	—	1750 ¹	—	—	0.007	86	23
	0.25	0.25	—	2650 ¹	—	—	0.015	75	23
		0.5	—	3400 ¹	—	—	0.0055	87	24
		1.0	—	4000 ¹	—	—	0.003	100	24
	0.5	0.5	—	4850 ¹	—	—	0.0055	76	23
		1.0	—	6100 ¹	—	—	0.003	94	24
		2.0	—	7150 ¹	—	—	0.0015	104	24
6C5 (Also 6J7, 6C6, 57, 6W7 as triodes) ⁴	0.05	0.05	—	2100	—	3.16	0.075	57	11
		0.1	—	2600	—	2.3	0.04	70	11
		0.25	—	3100	—	2.2	0.015	83	12
	0.1	0.1	—	3800	—	1.7	0.035	65	12
		0.25	—	5300	—	1.3	0.015	84	13
		0.5	—	6000	—	1.17	0.008	88	13
	0.25	0.25	—	9600	—	0.9	0.015	73	13
		0.5	—	12,300	—	0.59	0.008	85	14
		1.0	—	14,000	—	0.37	0.003	97	14
6C6, 6J7, 6W7, 57 (Pentode)	0.1	0.1	0.44	500	0.07	8.5	0.02	55	61
		0.25	0.5	450	0.07	8.3	0.01	81	82
		0.5	0.53	600	0.06	8.0	0.006	96	94
	0.25	0.25	1.18	1100	0.04	5.5	0.008	81	104
		0.5	1.18	1200	0.04	5.4	0.005	104	140
		1.0	1.45	1300	0.05	5.8	0.005	110	185
	0.5	0.5	2.45	1700	0.04	4.2	0.005	75	161
		1.0	2.9	2200	0.04	4.1	0.003	97	250
		2.0	2.95	2300	0.04	4.0	0.0025	100	240
6C8G (One triode unit)	0.1	0.1	—	2120	—	3.93	0.037	55	22
		0.25	—	2840	—	2.01	0.013	73	23
		0.5	—	3250	—	1.79	0.007	80	25
	0.25	0.25	—	4750	—	1.29	0.013	64	25
		0.5	—	6100	—	0.96	0.0065	80	26
		1.0	—	7100	—	0.77	0.004	90	27
	0.5	0.5	—	9000	—	0.67	0.007	67	27
		1.0	—	11,500	—	0.48	0.004	83	27
		2.0	—	14,500	—	0.37	0.002	96	28
6F5, 6SF5	0.1	0.1	—	1300	—	5.0	0.025	33	42
		0.25	—	1600	—	3.7	0.01	43	49
		0.5	—	1700	—	3.2	0.006	48	52
	0.25	0.25	—	2600	—	2.5	0.01	41	56
		0.5	—	3200	—	2.1	0.007	54	63
		1.0	—	3500	—	2.0	0.004	63	67
	0.5	0.5	—	4500	—	1.5	0.006	50	65
		1.0	—	5400	—	1.2	0.004	62	70
		2.0	—	6100	—	0.93	0.002	70	70
6F8G (one triode unit), 6J5, 6J5G	0.05	0.05	—	1020	—	3.56	0.06	41	13
		0.1	—	1270	—	2.96	0.034	51	14
		0.25	—	1500	—	2.15	0.012	60	14
	0.1	0.1	—	1900	—	2.31	0.035	43	14
		0.25	—	2440	—	1.42	0.0125	56	14
		0.5	—	2700	—	1.2	0.0065	64	14
	0.25	0.25	—	4590	—	0.87	0.013	46	14
		0.5	—	5770	—	0.64	0.0075	57	14
		1.0	—	6950	—	0.54	0.004	64	14
6L5G	0.05	0.05	—	1740	—	2.91	0.06	56	11 ⁵
		0.1	—	2160	—	2.18	0.032	68	12 ⁵
		0.25	—	2600	—	1.82	0.015	79	12 ⁵
	0.1	0.1	—	3070	—	1.64	0.032	60	12 ⁵
		0.25	—	4140	—	1.1	0.014	79	13 ⁵
		0.5	—	4700	—	0.81	0.0075	89	13 ⁵
	0.25	0.25	—	6900	—	0.57	0.013	64	13 ⁵
		0.5	—	9100	—	0.46	0.0075	80	13 ⁵
		1.0	—	10,750	—	0.4	0.005	88	13 ⁵

TABLE I—RESISTANCE-COUPLED AMPLIFIER DATA—Continued

	Plate Resistor Megohms	Next-Stage Grid Resistor Megohms	Screen Resistor Megohms	Cathode Resistor Ohms	Screen By-pass μ f.	Cathode By-pass μ f.	Blocking Condenser μ f.	Output Volts (Peak) ²	Voltage Gain ³
6R7, 6R7G	0.05	0.05	—	1600	—	2.6	0.055	50	9
		0.1	—	2000	—	2.0	0.03	62	9
		0.25	—	2400	—	1.6	0.015	71	10
	0.1	0.1	—	2900	—	1.4	0.03	52	10
		0.25	—	3800	—	1.1	0.015	68	10
		0.5	—	4400	—	1.0	0.007	71	10
0.25	0.25	—	6300	—	0.7	0.015	54	10	
	0.5	—	8400	—	0.5	0.007	62	11	
	1.0	—	10,600	—	0.44	0.004	74	11	
6S7	0.1	0.1	0.59	430	0.077	8.5	0.0167	57	57 ⁵
		0.25	0.67	440	0.071	8.0	0.01	73	78 ⁵
		0.5	0.71	440	0.071	8.0	0.0066	82	89 ⁵
	0.25	0.25	1.7	620	0.058	6.0	0.0071	54	98 ⁵
		0.5	1.95	650	0.057	5.8	0.005	66	122 ⁵
		1.0	2.1	700	0.055	5.2	0.0036	76	136 ⁵
0.5	0.5	3.6	1000	0.04	4.1	0.0037	52	136 ⁵	
	1.0	3.9	1080	0.041	3.9	0.0029	66	162 ⁵	
	2.0	4.1	1120	0.043	3.8	0.0023	73	174 ⁵	
6SC7	0.1	0.1	—	750 ¹	—	—	0.033	35	99
		0.25	—	930 ¹	—	—	0.014	50	34
		0.5	—	1040 ¹	—	—	0.007	54	36
	0.25	0.25	—	1400 ¹	—	—	0.012	45	39
		0.5	—	1680 ¹	—	—	0.006	55	42
		1.0	—	1840 ¹	—	—	0.003	64	45
0.5	0.5	—	2330 ¹	—	—	0.006	50	45	
	1.0	—	2980 ¹	—	—	0.003	62	48	
	2.0	—	3280 ¹	—	—	0.002	72	49	
6SJ7	0.1	0.1	0.35	500	0.10	11.6	0.019	72	67
		0.25	0.37	530	0.09	10.9	0.016	96	98
		0.5	0.47	590	0.09	9.9	0.007	101	104
	0.25	0.25	0.89	850	0.07	8.5	0.011	79	139
		0.5	1.10	860	0.06	7.4	0.004	88	167
		1.0	1.18	910	0.06	6.9	0.003	98	185
0.5	0.5	2.0	1300	0.06	6.0	0.004	64	200	
	1.0	2.2	1410	0.05	5.8	0.002	79	238	
	2.0	2.5	1530	0.04	5.2	0.0015	89	263	
6SQ7, 6B6G, 2A6, 75	0.1	0.1	—	1900	—	4.0	0.03	31	31
		0.25	—	2200	—	3.5	0.015	41	39
		0.5	—	2300	—	3.0	0.007	45	42
	0.25	0.25	—	3300	—	2.7	0.015	42	48
		0.5	—	3900	—	2.0	0.007	51	53
		1.0	—	4200	—	1.8	0.004	60	56
0.5	0.5	—	5300	—	1.6	0.007	47	58	
	1.0	—	6100	—	1.3	0.004	62	60	
	2.0	—	7000	—	1.2	0.002	67	63	
6T7G	0.1	0.1	—	1950	—	2.85	0.0245	44	27 ⁵
		0.25	—	2400	—	2.55	0.0135	58	39 ⁵
		0.5	—	2640	—	2.25	0.008	64	33 ⁵
	0.25	0.25	—	3760	—	1.57	0.012	57	37 ⁵
		0.5	—	4580	—	1.35	0.0075	69	40 ⁵
		1.0	—	5220	—	1.23	0.005	80	41 ⁵
0.5	0.5	—	6570	—	1.02	0.008	62	42 ⁵	
	1.0	—	8200	—	0.82	0.0055	77	43 ⁵	
	2.0	—	9600	—	0.70	0.004	86	44 ⁵	
56, 76	0.05	0.05	—	2400	—	2.8	0.08	65	8.3
		0.1	—	3100	—	2.2	0.045	80	8.9
		0.25	—	3800	—	1.8	0.02	95	9.4
	0.1	0.1	—	4500	—	1.6	0.04	74	9.5
		0.25	—	6400	—	1.2	0.02	95	10.0
		0.5	—	7500	—	0.98	0.009	104	10.0
0.25	0.25	—	11,100	—	0.69	0.02	82	10.0	
	0.5	—	15,200	—	0.5	0.009	96	10.0	
	1.0	—	18,300	—	0.4	0.005	108	10.0	

¹ Value for both triode sections, assuming both are working under same conditions. In phase inverter service, the cathode resistor should not be by-passed.

² Voltage across next-stage grid resistor at grid-current point.

³ At 5 volts r.m.s. output.

⁴ Screen and suppressor tied to plate.

⁵ At 4 volts r.m.s. output.

The Radio Amateur's Handbook

TABLE II—CLASS-B MODULATOR DATA

See also Receiving Tube Tables (Chapter 20) for Data on Class A, AB₁ and AB₂ Amplifiers for Use as Low-Power Modulators.

Class-B Tubes (2)	Fil. Volts	Plate Volts	Grid Volts App.	Peak A.F. Grid-to-Grid Voltage	Zero-Sig. ¹ Plate Current Ma.	Max.-Sig. ¹ Plate Current Ma. ²	Load Res. Plate-to-Plate Ohms	Max.-Sig. Driving Power Watts ³	Max.-Sig. ¹ Power Output Watts ²
HY60 ⁴	6.3	300 400	-22.5 -22.5	63 57	75 75	120 120	5,000 6,000	4.0 3.0	22 30
801	7.5	600	-75	320	8	130	10,000	3.0	45
HY31Z ¹⁰	6.3	300 400 500	0 0 0	104 140 131	20 26 36	100 150 150	5,000 5,000 7,000	1.4 2.0 1.8	18 40 51
RK66 ⁴	6.3	600	-35	—	—	55	8,000	0.4	65
1624 ⁴	2.5	400 600	-16.5 -25	77 106	75 42	150 180	6,000 7,500	0.4 1.2	36 72
TZ20	7.5	750	0	195	—	170	9,000	2.6	80
HY69 ⁴	6.3	600 500	-35 -25	183 120	65 65	120 200	4,500 5,000	7.0 3.0	65 97
RK12	6.3	750	0	129	50	200	9,600	3.4	100
800	7.5	750 1000 1250	-40 -55 -70	320 300 300	26 28 30	210 160 130	6,400 12,500 21,000	6.0 4.4 3.4	90 100 106
HY30Z	6.3	600 750 850	0 0 0	171 167 171	18 22 28	180 180 180	6,000 8,000 10,000	Note 5 " "	75 95 110
807 ⁶	6.3	400 500 600 750 ⁷	-25 -25 -30 -32	80 80 80 95	100 100 60 60	230 230 200 240	3,800 4,550 6,660 7,320	0.35 0.6 0.4 0.5	60 75 80 120
809 1623	6.3	500 750 1000 ⁷	0 -4.5 -10	135 140 156	40 40 40	200 200 200	5,200 8,400 11,600	2.4 2.4 3.4	60 100 145
830-B	10	800 1000	-27 -35	250 270	20 20	280 280	6,000 7,600	5.0 6.0	135 175
HY40Z	7.5	750 850 1000	0 0 0	171 185 185	32 40 45	225 250 250	6,000 7,000 9,000	Note 5 " "	110 155 185
808	7.5	1250 1500	-15 -16	240 110	40 30	230 190	12,700 18,300	7.8 4.8	185 190
811	6.3	1250 1500 ⁷	0 -9	140 160	48 20	200 200	15,000 18,000	3.8 4.2	175 225
35T	5.0 to 5.1	750 1000 1250 1500	0 -22 -30 -40	— — — —	— — — —	— — — —	6,000 7,200 9,600 12,800	— — — —	100 150 200 230
154	5.0	750 1000 1250 1500	-100 -155 -210 -265	430 510 600 700	40 50 60 80	350 300 256 230	4,000 7,500 11,400 16,000	10 10 10 10	150 200 223 250
TZ40 ⁷	7.5	1000 1250 1500	0 -4.5 -9	220 269 265	— — —	280 280 250	7,350 10,000 12,000	5.5 6.0 6.0	175 225 250
RK52	7.5	1250	0	180	40	300	10,000	7.5	250
RK58	10	1250	0	200	148	320	9,000	7.5	260
203-A	10	1000 1250	-35 -45	310 330	26 26	320 320	6,900 9,000	10 11	200 260
838	10	1000 1250	0 0	90 90	106 148	320 320	7,600 11,200	5.0 5.0	200 260
211	10	1000 1250	-77 -100	380 410	20 20	320 320	6,900 9,000	7.5 8.0	200 260
HY51Z	7.5	850 1000 1250	0 0 0	148 170 155	48 60 90	300 350 300	5,000 6,000 10,000	Note 5 " "	160 260 285

TABLE II—CLASS-B MODULATOR DATA—Continued

Class-B Tubes (2)	Fil. Volts	Plate Volts	Grid Volts App.	Peak A.F. Grid-to-Grid Voltage	Zero-Sig. ¹ Plate Current Ma.	Max.-Sig. ¹ Plate Current Ma. ²	Load Res. Plate-to-Plate Ohms	Max.-Sig. Driving Power Watts ³	Max-Sig. ¹ Power Output Watts ⁴	
203-Z	10	1000 1250	0 -4.5	206 215	50 60	350 350	6,200 8,000	6.5 6.75	230 300	
ZB120	10	750 1000 1250 1500	0 0 0 -9	190 190 180 196	50 70 95 60	320 310 300 296	4,800 6,900 9,000 11,200	5.0 5.0 4.0 5.0	150 200 245 300	
RK38	5.0	2000	-52	357	36	265	16,000	5.8	330	
HF100	10 to 11	1500 1750	-52 -62	264 324	50 40	270 270	12,000 16,000	2.0 9.0	260 350	
852	10	2000 3000	-155 -250	600 780	22 14	180 160	22,000 36,000	3.5 3.5	220 360	
805 RK57	10	1250 1500	0 -16	235 280	148 84	400 400	6,700 8,200	6.0 7.0	300 370	
828 ⁵	10	1700 2000	-120 ⁶ -120 ⁶	240 240	50 50	248 270	16,200 18,300	— —	300 385	
75T	5.0	1000 1500 2000	— — —	— — —	— — —	— — —	6,800 10,000 12,500	— — —	200 300 400	
810	10	1500 2000	-30 -50	345 345	80 60	500 420	6,600 11,000	12 10	510 590	
100TL	5.0 to 5.1	1000 1250 1500 2000 2500 3000	Bias adjusted for maximum rated plate dissipation under no-signal conditions					5,200 7,200 9,600 16,000 22,000 30,000	May be driven by push-pull 6L6's	170 230 270 350 435 465
100TH	5.0 to 5.1	1000 1250 1500 2000 2500 3000	Bias adjusted for maximum rated plate dissipation under no-signal conditions Zero bias up to 1250 v. plate					5,200 7,200 9,600 16,000 22,000 30,000	May be driven by push-pull 6L6's	210 260 300 380 460 500
806	5.0	2000	-150	340	20	390	11,500	14	500	
HD 203-A	10	1500 1750	-40 -67	— —	36 36	425 425	8,000 9,000	Note 9	400 500	
250TL 250TH	5.0 to 5.1	1000 1250	Bias adjusted for maximum rated plate dissipation under no-signal conditions. 250TH used with zero bias up to 1400 v. plate					2,360 3,280	May be driven by p.p. 6L6's	350 540
354 354C	5.0	1000 1500 2000 2500	-60 -95 -125 -165	340 440 500 560	40 60 100 80	252 267 294 236	10,000 10,000 10,000 15,000	14 20 20 20	162 315 448 577	
354D	5.0	1500 2500	-60 -112	350 430	50 50	277 290	12,000 20,000	20 20	302 519	
354E	5.0	1500 2500	-25 -50	334 384	50 50	325 348	10,000 16,000	20 20	319 595	
354F	5.0	1500 2500	-15 -35	274 310	50 50	280 300	12,000 20,000	20 20	290 550	

¹ Values are for both tubes.

² Sinusoidal signal values; speech values are approximately one-half for tubes biased to approximate cut-off and 80% for zero-bias tubes.

³ Values do not include transformer losses. Somewhat higher power is required of the driver to supply losses and provide good regulation. Input transformer ratios must be chosen to supply required power at specified grid-to-grid voltage with ample reserve for losses and low distortion levels. Driver stage should have good regulation.

⁴ Beam tube. Class AB. Screen voltage: 300.

⁵ Driver: one or two 45's at 275 volts, self-bias (-55 v.).

⁶ Beam tube. Class AB. Screen voltage: 300 at 10 ma. Effective grid circuit resistance should not exceed 500 ohms.

⁷ Intermittent amateur and commercial service rating.

⁸ Pentode. Class AB. Suppressor volts: 60 at 9 ma. Screen volts: 750, 4/43 ma. at 1700 plate volts, 2/60 ma. at 2000.

⁹ Can be driven by a pair of 2A3's in push-pull Class-AB at 300 volts with fixed bias.

¹⁰ Dual tube. Values are for one tube, both sections.

The Radio Amateur's Handbook

may be regulated to some extent by varying the leak resistance. Alternatively, a modulation transformer with tapped secondary may be used, the grid modulation being adjusted by choice of a suitable tap.

The following table shows how the plate input and plate efficiency of the r.f. amplifier, and the required audio power for 100% modulation, vary with the different types of modulation. Suppressor modulation is equivalent to grid-bias modulation in this tabulation. The figures are based on a carrier output of 100 watts in all cases.

	Plate Mod.	Cathode Mod. ($m=40\%$)	Grid-Bias Mod. ($m=20\%$)	Grid-Bias Mod.
Carrier output, watts	100	100	100	100
D.c. plate input, watts	129	178	228	300
Plate dissipation, watts	29	78	128	200
Audio power required, watts	65	36	23	—

● THE MODULATOR

The determining factors in the design of the audio equipment of a 'phone transmitter are the microphone output and the audio power required for modulating the r.f. stage. The process is therefore essentially one of working backward from the modulator to the microphone.

Class-B Modulators

The preceding discussion has shown that modulator output requirements vary widely with the type of modulation system chosen. In the case of plate modulation, the relatively-large audio power needed practically dictates the use of a Class-B modulator, since the power can be obtained most economically with this type of amplifier. A typical circuit is given in Fig. 610, and operating data on various tubes as Class-B audio amplifiers in Table I. The power outputs are for a pure-tone signal, which is the basis of design. A pair of tubes must be chosen which is capable of delivering sine-wave audio power equal to half the d.c. input to the modulated Class-C amplifier, as already described. Any type of tube meeting this condition will be satisfactory. It is sometimes convenient to use tubes which will operate at the same plate voltage applied to the Class-C stage, since one power supply of adequate current capacity may suffice for both stages. In other cases, better overall per-

formance and economy may result from the use of separate power supplies. This is a matter for individual consideration, and generalization is not possible.

Matching Modulator to Modulated Amplifier

The plate-to-plate load impedance specified for rated power output of the Class-B modulator seldom corresponds to the modulating impedance of the Class-C r.f. stage, so that a match must be brought about by adjusting the **turns ratio** of the coupling transformer. The required turns ratio, primary to secondary, is

$$\sqrt{\frac{Z_p}{Z_m}}$$

where Z_m is the Class-C modulating impedance and Z_p is the plate-to-plate load impedance specified for the Class-B tubes.

Commercial Class-B output transformers usually are rated to work between specified primary and secondary impedances and are designed for specific Class-B tubes. This is simply a "shorthand" way of stating the turns ratio, which can be found by substituting the given impedances in the formula above. Many transformers are provided with primary and secondary taps so that various turns ratios can be obtained to meet the requirements of a large number of tube combinations.

Driving Power

Class-B amplifiers are driven into the grid-current region, so that power is consumed in the grid circuit. The preceding stage or driver must be capable of supplying this power at the required peak audio-frequency grid-to-grid voltage. Both these quantities are given in Table I. The grids of the Class-B tubes represent a variable load resistance over the audio-frequency cycle, since the grid current does not increase directly with the grid voltage. To prevent distortion, therefore, it is necessary to have a driving source which has good **regulation** — that is, which will maintain the waveform of the signal even though the load varies. This can be brought about by using a driver capable of delivering two or three times

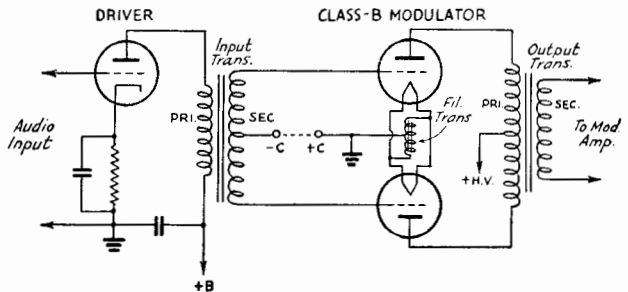

Fig. 610 — Class-B modulator and driver circuit.

Modulation

the actual power consumed in the Class-B grids, and by using an input coupling transformer having a turns ratio giving the largest step-down in voltage, between the driver plate or plates and Class-B grids, that will permit obtaining the specified grid-to-grid a.f. voltage.

Driver Coupling

A Class-A or Class-AB driver is universally used to excite a Class-B stage. Tubes for the driver preferably should be triodes having low plate resistance, since these will have the best regulation. Having chosen a tube or tubes with ample power output (the data in the tube tables in Chapter 20 may be used) the peak output voltage will be, approximately,

$$E_o = 1.4 \sqrt{PR}$$

where P is the power output and R the load resistance. The input transformer ratio, primary to secondary, will be

$$\frac{E_o}{E_p}$$

where E_o is as given above and E_p is the peak grid-to-grid voltage given in Table I for the modulator tubes chosen.

Commercial transformers usually are designed for specific driver-modulator combinations, and usually are adjusted to give as good driver regulation as the conditions will permit.

Grid Bias

Modern Class-B audio tubes are intended for operation without fixed bias. This lessens the variable loading effect and eliminates the need for a grid-bias supply.

When a grid-bias supply is required, it must have low internal resistance so that the flow of grid current with excitation of the Class-B tubes does not cause a continual shift in the actual grid bias and thus cause distortion. Batteries or a regulated bias supply (Chapter 11) should be used.

Plate Supply

The plate supply for a Class-B modulator should be sufficiently well filtered to prevent hum modulation of the r.f. stage. The design data in Chapter 11 should be followed. An additional requirement is that the output condenser of the supply should have low reactance at 100 cycles or less compared to the load into which each tube is working, which is $\frac{1}{4}$ the plate-to-plate load resistance. A 4- μ fd. output condenser with a 1000-volt supply, or a 2- μ fd. condenser with a 2000-volt supply, usually will be satisfactory, with other values in proportion to the plate voltage.

The plate supply for the modulated amplifier, in all modulation systems, must also be well filtered to prevent hum. The output condenser of the supply should have low reactance compared to the modulating impedance of the stage. The values given above are satisfactory.

Low-Level Modulators

Modulators for grid-bias and suppressor modulation usually can be small audio power output tubes, since the audio power required is quite small. A triode such as the 2A3 is preferable because of its low plate resistance, but pentodes will work satisfactorily. It is usual practice to load the primary of the output coupling transformer with a resistance equal to or slightly larger than the rated load resistance for the tube in order to stabilize the voltage output and thus improve the regulation.

Since the ordinary Class-A receiving power tube will develop about 200 to 250 peak volts in its plate circuit, which is ample for most low-level modulator applications, a 1:1 coupling transformer is generally used. If more voltage is required, a step-up ratio must be provided in the transformer.

● TYPES OF MICROPHONES

The microphone is next in line for consideration after the modulator has been selected, since the output of the microphone and the

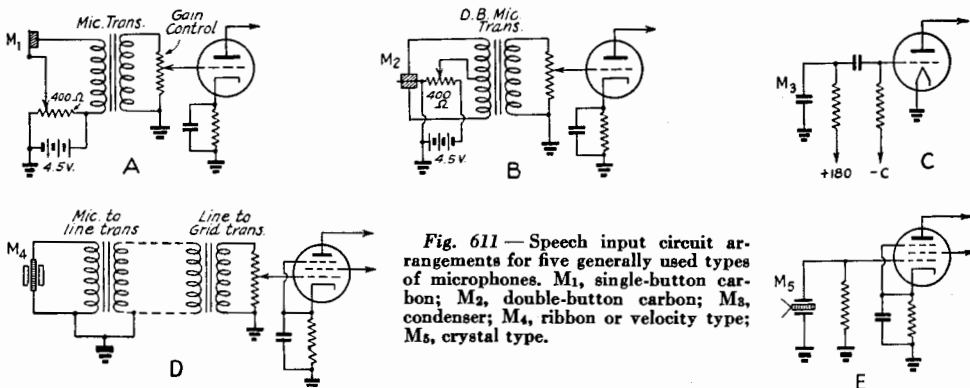

Fig. 611—Speech input circuit arrangements for five generally used types of microphones. M_1 , single-button carbon; M_2 , double-button carbon; M_3 , condenser; M_4 , ribbon or velocity type; M_5 , crystal type.

The Radio Amateur's Handbook

driving requirements of the modulator will determine the amount of amplification needed between the two.

The **sensitivity** of the microphone is its electrical output for a given speech intensity input. Sensitivity varies greatly with microphones of different basic types, and also varies between different models of the same type. The output is also greatly dependent on the character of the individual voice and the distance of the speaker's lips from the microphone, decreasing approximately as the square of the distance. It also may be affected by reverberation in the room. Hence, only approximate values based on averages of "normal" speaking voices can be attempted. The values to be given are based on close talking; that is, with the microphone six inches or less from the speaker's lips.

Carbon Microphones

Fig. 611 shows connections for single- and double-button carbon microphones, with a variable potentiometer included in each circuit for adjusting the button current to the correct value as specified with each microphone. The operation of the single-button type has already been explained. The double-button type operates similarly, but with two buttons in push-pull.

Good quality single-button carbon microphones give outputs ranging from 0.1 to 0.3 volt across 50 to 100 ohms; that is, across the primary winding of the microphone transformer. With the step-up of the transformer, a peak voltage of between 3 and 10 volts across 100,000 ohms or so can be assumed available at the grid of the first tube. These microphones are usually operated with a button current of 50 to 100 ma.

The sensitivity of good-quality double-button microphones is considerably less, ranging from 0.02 volt to 0.07 volt across 200 ohms. With this type microphone, and the usual push-pull input transformer, a peak voltage of 0.4 to 0.5 volt across 100,000 ohms or so can be assumed available at the first speech amplifier grid. The button current with this type microphone ranges from 5 to 50 ma. per button.

Condenser Microphones

The condenser microphone of Fig. 611-C consists of a two-plate capacity with one plate stationary and the other, separated from the first by about a thousandth of an inch, a thin metal membrane serving as a diaphragm. This condenser is connected in series with a resistor and d.c. voltage source. When the diaphragm vibrates the change in capacity causes a small charging current to flow through the circuit. The resulting audio voltage which appears across the resistor is fed to the tube grid through the coupling condenser.

The output of condenser microphones varies with different models, the high-quality type being about one-hundredth to one-fiftieth as sensitive as the double-button carbon microphone. The first amplifier tube must be built into the microphone since the capacity of a connecting cable would impair both output and frequency range.

Velocity Microphones

In a velocity or ribbon microphone, the element acted upon by the sound waves is a thin corrugated metallic ribbon suspended between the poles of a magnet. When made to vibrate the ribbon cuts the lines of force between the poles in first one direction and then the other, thus generating an alternating voltage.

The sensitivity of the velocity microphone, with a suitable coupling transformer, is about 0.03 to 0.05 volt.

The dynamic microphone is similar to the ribbon type in principle, but the ribbon is replaced by a coil attached to a diaphragm. The coil provides several turns of wire cutting the magnetic field, and thus gives greater sensitivity. A small permanent-magnet loud-speaker makes a practical dynamic microphone.

Crystal Microphones

The input circuit for a piezo-electric or crystal type microphone is shown in Fig. 612-E. The element in this type consists of a pair of Rochelle salts crystals cemented together, with plated electrodes. In the more sensitive types the crystal is mechanically coupled to a diaphragm. Sound waves actuating the diaphragm cause the crystal to vibrate mechanically and, by piezo-electric action, to generate a corresponding alternating voltage between the electrodes, which are connected across the grid circuit of a vacuum tube amplifier as shown. Unlike the other microphones described, the crystal type requires no separate source of current, voltage or magnetic field.

Although the sensitivity of crystal microphones varies with different models, an output of 0.01 to 0.03 volt is representative for amateur communication types. The sensitivity is affected by the length of the cable connecting to the first amplifier stage; the above figure is for lengths of 6 or 7 feet. The frequency characteristic is unaffected by the cable but the load resistance (amplifier grid resistor) does affect it, the lower frequencies being attenuated as the shunt resistance becomes less. Grid resistor values of 1 megohm and higher should be used, 5 megohms being a customary figure.

Frequency Range

Wide frequency response in speech input equipment is not required for voice transmis-

Modulation

sion, uniform frequency response from 100 to about 3000 cycles being adequate. It is therefore satisfactory to choose a microphone intended particularly for speech transmission, rather than one designed for broadcast program use. Since the high r.f. selectivity of modern amateur 'phone receivers and the use of "tone controls" in receiver audio systems cut off the higher frequencies anyway, the transmitted modulation frequencies above 3000 cycles are largely wasted.

● THE SPEECH AMPLIFIER

The function of the speech amplifier is to provide sufficient gain after the microphone so that the modulator will be driven to the required output. There are two practical cases: first, where audio power is required for the grids of Class-B modulators; second, where voltage only, with negligible power, is needed for driving a Class-A modulator.

With a Class-B modulator, the first step is the selection of a suitable driver, as already described. In nearly all cases the driver will operate Class-A, or Class-AB without grid current, so that no power is consumed in its grid circuit. The peak audio voltage needed for full output of the driver chosen can be found from the tables in Chapter 20, being equal to the operating grid bias unless otherwise specified.

Overall Gain

The minimum voltage gain required in the speech amplifier will be

$$\frac{E_g}{E_m}$$

where E_g is the peak grid voltage just found and E_m is the peak voltage output of the microphone (from the microphone transformer, if one is used). If a Class-A modulator is used, the required voltage gain may be calculated from the same formula, using the operating grid bias of the modulator for E_g . It is good practice to multiply the minimum gain figure by 2 or 3 in designing the speech amplifier so that ample gain will be available for meeting varying conditions.

The required gain usually can be attained in two or three stages by selecting suitable tubes from Table II. For example, when a stage giving a gain of 100 is followed by one giving a gain of 15, the total gain is 100×15 , or 1500.

Resistance Coupling

Typical resistance-coupled circuits are given in Fig. 612. Resistance coupling is preferred, especially in high gain amplifiers, because it is relatively inexpensive, good frequency response can be secured, and there is little danger of hum pickup from stray magnetic fields. The use of a

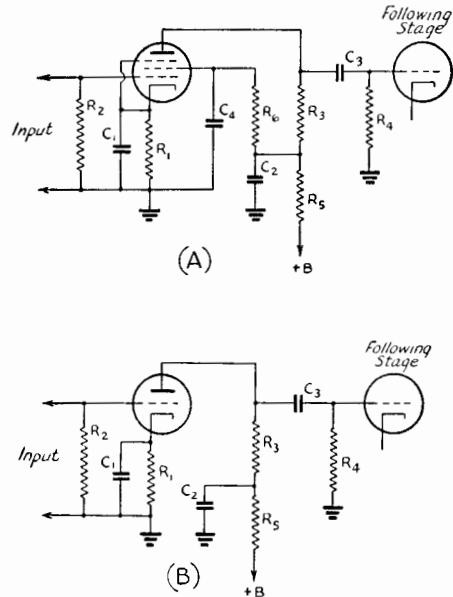

Fig. 612 — Resistance-coupled voltage amplifier circuits. A, pentode; B, triode. Designations are as follows:

- C₁ — Cathode by-pass condenser.
- C₂ — Plate by-pass condenser.
- C₃ — Output coupling condenser (blocking condenser).
- C₄ — Screen by-pass condenser.
- R₁ — Cathode resistor.
- R₂ — Grid resistor.
- R₃ — Plate resistor.
- R₄ — Next-stage grid resistor.
- R₅ — Plate decoupling resistor.
- R₆ — Screen resistor.

Values are given in Table II, except R₂ and R₅. R₂ will depend upon the previous stage, since it is the "next stage grid resistor" for that stage. Values up to 1 megohm may be used with small receiving tubes. R₅ is usually about 20% of the value of R₃.

decoupling resistor, R₅, is good practice since it tends to prevent feedback between stages because of common coupling through the power supply.

Transformer Coupling

Transformer coupling between stages is seldom used except in cases where it is necessary to go from a single-ended stage to a push-pull stage, or when power is to be transferred. In the latter case resistance coupling is highly inefficient, but the necessity for power transfer does not arise in purely voltage amplifiers. Representative circuits for single-ended to push-pull, frequently used for exciting the grids of a Class-A or AB driver for a Class-B amplifier, are shown in Fig. 613. In A, a plate resistor is used for coupling, through the blocking condenser C₃, to the transformer primary. The values given in Table II should be used, and the gain is that given in Table II multiplied by the secondary-to-primary turns ratio of the

The Radio Amateur's Handbook

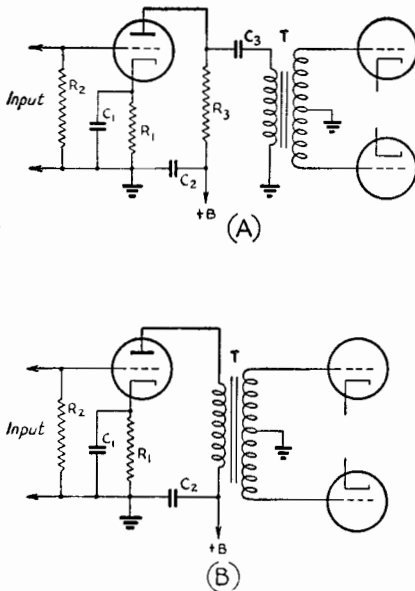

Fig. 613 — Transformer-coupled amplifier circuits for driving a push-pull amplifier. *A*, resistance-transformer coupling; *B*, transformer coupling. Designations correspond to those of Fig. 611. In *A*, values can be taken from Table II. In *B*, the cathode resistor is calculated from the rated plate current and grid bias as given for the particular type of tube used as listed in Chapter 20. *A* is preferable for best frequency characteristic, *B* for transferring power to the following grids, or for maximum voltage gain.

transformer. This ratio usually is 2:1. In this circuit the transformer primary does not carry direct current, which is advantageous in improving the frequency response.

In *B* the transformer primary is in series with the plate of the tube and thus must carry the tube plate current. When the following amplifier operates without grid current, the voltage gain of the stage is practically equal to the μ of the tube multiplied by the transformer ratio.

Triodes having an amplification factor of 20 or less are used in transformer-coupled voltage amplifiers, since practicable transformers do not have high enough primary impedance to give good gain and frequency response when used with pentodes or high- μ triodes.

Voltage Output

The column marked "Output Volts" in Table II is important in the selection of the tube to excite the modulator or driver. A tube capable of delivering the necessary peak voltage must be used for this purpose. This column shows the maximum output voltage obtainable without distortion, assuming that the signal at the grid is large enough to produce this voltage.

In stages preceding the last voltage amplifier this column may be ignored, since low-level

tubes are never worked near full capacity. In these stages the voltage gain is the important consideration.

Phase Inversion

Push-pull output may be secured with resistance coupling by using an extra tube as shown in Fig. 614. There is a phase shift of 180 degrees through any normally-operating resistance-coupled stage, and the extra tube is used purely to provide this phase shift without additional gain. The outputs of the two tubes are then added to give push-pull excitation to the next amplifier.

In Fig. 614, V_1 is the regular amplifier, connected in normal fashion to the grid of one of the push-pull tubes. The next-stage grid resistor is tapped so that part of the output voltage is fed to the grid of the phase inverter, V_2 . This tube then amplifies the signal and applies it in reverse phase to the grid of the

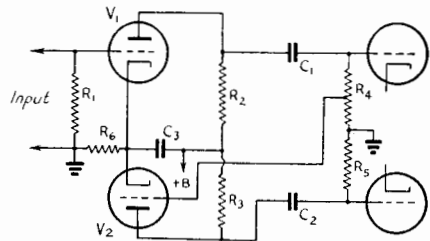

Fig. 614 — Phase inversion circuit for driving a push-pull amplifier without a transformer. R_1 , grid resistor; R_2 and R_3 , plate load resistors; R_4 and R_5 , next stage grid resistors; C_1 and C_2 , blocking or coupling condensers; C_3 , plate by-pass condenser. R_6 is equal to half the value specified in the table if separate tubes are used at V_1 and V_2 ; for double triodes such as the 6N7 the cathode resistor is given for both triode sections.

second push-pull tube. Two similar tubes should be used at V_1 and V_2 , with identical plate resistors and output coupling condensers. The tap on R_4 is adjusted to make V_1 and V_2 give equal voltage outputs so that balanced excitation is applied to the grids of the following stage.

The cathode resistor, R_6 , commonly is left un-bypassed since this tends to help balance the circuit. Double-triode tubes are frequently used as phase inverters.

Choosing a Tube Lineup

When high gain is required, a pentode ordinarily is used as the first voltage amplifier. The second and third tubes generally are triodes. There is less danger of instability with the pentode-triode combination than with a pentode followed by a pentode.

As an illustration of design, suppose that a Class-B modulator which requires 5 watts of driving power is to be used. Consulting the tables in Chapter 20, and bearing in mind the

desirability of providing more driving power than is actually used, it is found that push-pull 2A3's giving 10 watts output will make a satisfactory driver. The grid bias required is 62 volts, so that the peak grid-to-grid voltage will be 124 volts (actually, a slightly higher voltage will be needed since the tubes will be working Class-AB and, with self-bias, the operating bias will rise somewhat under full output; this is taken care of in the allowance for reserve gain in the voltage amplifier). Assume that a crystal microphone, having an output of 0.01 volt, is to be used.

The 2A3's are to be coupled to the preceding amplifier through a transformer having a 2:1 step-up ratio, therefore the preceding stage must be capable of a voltage output of at least $124/2$, or 62 peak volts. A 6C5 is capable of this output with the circuit shown in Fig. 613-B, since with this circuit the voltage output can be as high as the highest figure for a particular type of tube in Table II. The tube gain will be approximately equal to the μ , which from the tube tables of Chapter 20 is found to be 20. The signal required at the 6C5 grid is $62/20$, or 3.1 volts. A 6J7 following the microphone can give a gain (from Table II) of, say, 104, so that its output will be 104×0.01 , or 1.04 peak volts. One more stage capable of a gain of

Fig. 615 — Block diagram of a typical speech amplifier, showing voltage gain and signal level at each.

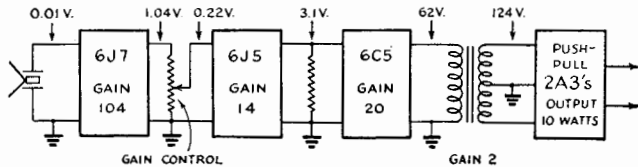

3.1/1.04, or about 3, is needed. Allowing a factor of safety, a 6J5 with a gain of 15 will provide ample gain.

The speech amplifier then will look, in block form, like Fig. 615.

Gain Control

Gain control methods are similar to those used in audio amplifiers in receivers (Chapter 4). The gain control potentiometer should be near the input end of the amplifier so that there will be no danger that stages ahead of the gain control will overload. With carbon microphones the gain control may be placed directly across the microphone transformer secondary, but with other types the gain control usually will affect the frequency response of the microphone when connected directly across it. The control is therefore usually placed in the grid of the second stage.

Output Limiting

It is desirable to modulate as heavily as possible without overmodulating, yet it is

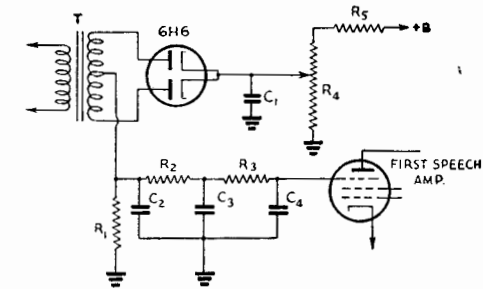

Fig. 616 — Output limiting circuit to prevent over-modulation.

C_1, C_2, C_3, C_4 — 0.1- μ fd. paper.
 R_1, R_2, R_3 — 250,000 ohms.
 R_4 — 25,000-ohm potentiometer.
 R_5 — 100,000 ohms.
 T — See text.

difficult to speak into the microphone at a constant intensity. To maintain reasonably constant output from the modulator in spite of variations in speech intensity, it is possible to use automatic gain control which follows the average (not instantaneous) variations in speech amplitude. This is accomplished by rectifying and filtering some of the audio output and applying the rectified and filtered d.c. to a control electrode in an early stage in the

amplifier. The principle is similar to that of a.v.c. in a receiver.

A practical circuit for this purpose is shown in Fig. 616. The rectifier must be connected, through the transformer, to a tube capable of delivering some power output (a small part of the output of the power stage may be used) or else a separate amplifier for the rectifier circuit alone may have its grid connected in parallel with that of the last voltage amplifier. Resistor R_4 in series with R_5 across the plate supply provides variable bias on the rectifier plates so that the limiting action can be delayed until a desired microphone input level is reached. R_2, R_3 and C_2, C_3, C_4 form the filter, and the output of the rectifier is connected to the suppressor grid of the pentode first stage of the speech amplifier.

A step-down transformer giving about 50 volts when its primary is connected to the output circuit should be used. A half-wave rectifier can be used instead of the full-wave circuit shown, although satisfactory filtering is more difficult.

Workshop Practice

Tools — Constructional Methods — Coil Winding

IN CONTRAST to earlier days of amateur radio, when many components were available only at prohibitive prices or not at all, the construction of a piece of equipment today resolves itself chiefly into proper assembly and wiring of the various components.

● TOOLS

While the greater the variety of tools available, the easier and, perhaps, the better the job may be done, with a little thought and care it is possible to turn out a fine piece of equipment with comparatively few common hand tools. A list of tools which will be found indispensable in the construction of amateur equipment will be found on this page. With these tools it should be possible to perform any of the required operations in preparing panels and metal chassis for assembly and wiring. A few additional tools will make certain operations easier, so it is a good idea for the amateur who does constructional work at intervals to add to his supply of tools from time to time. The following list will be found helpful in making a selection:

Bench vise, 4-in. jaws

INDISPENSABLE TOOLS

Long-nose pliers, 6-in.
Diagonal cutting pliers, 6-in.
Screwdriver, 6- to 7-in., $\frac{1}{4}$ -in. blade
Screwdriver, 4- to 5-in., $\frac{1}{8}$ -in. blade
Scratch awl or ice pick for marking lines
Combination square, 12-in. for laying out work
Hand drill, $\frac{1}{4}$ -in. chuck or larger, 2-speed type preferable
Electric soldering iron, 100 watts
Hack saw, 12-in. blades
Center punch for marking hole centers
Hammer, ball pien, 1-lb. head
Heavy knife
Yardstick or other straight edge
Carpenter's brace with adjustable hole cutter or socket-hole punches (see text)
Pair small "C" clamps for holding work
Large coarse flat file
Large round or rat-tail file, $\frac{1}{2}$ -in. diameter
Three or four small and medium files, flat, round, half-round, triangular
Drills, particularly $\frac{1}{4}$ -in., and Nos. 18, 28, 33, 42 and 50
Combination oil stone for sharpening tools
Solder and soldering paste (non-corroding)
Medium-weight machine oil

Tin shears, 10-in. for cutting thin sheet metal
Taper reamer, $\frac{1}{2}$ -in. for enlarging small holes

Taper reamer, 1-in. for enlarging holes

Countersink for brace

Carpenter's plane, 8- to 12-in. for woodworking

Carpenter's saw, cross-cut

Motor-driven emery wheel for grinding

Long-shank screwdriver with screw-holding clip for tight places

Set of "spintite" socket wrenches for hex nuts

Set small flat open-end wrenches for hex nuts

Wood chisel, $\frac{1}{2}$ -in.

Cold chisel, $\frac{1}{2}$ -in.

Wing dividers, 8-in. for scribing circles

Set machine-screw taps and dies

Folding rule, 6-ft.

Dusting brush

Several of the pieces of light woodworking machinery, often sold in hardware stores and

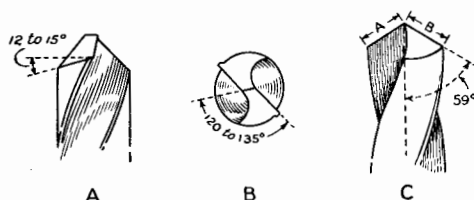

Fig. 701 — Important surface angles in drill sharpening. The point surfaces of the drill should be ground back from the cutting surfaces so that they are higher than the rest of the surfaces; the angle of 12 to 15 degrees shown at A is quite critical. The angle between the center point of the drill and the cutting edges should be 120 to 135 degrees, as shown at B. The best angle between the axis of the drill and the cutting edge is 50 degrees, as shown at C. It is highly important to keep the length of the cutting edges A and B equal.

mail-order retail stores, are ideal for amateur radio work, especially the drill press, grinding head, band and circular saws and joiner. Although unnecessary, they are mentioned here for those who may be in a position to acquire them.

Care of Tools

To a good workman, the proper care of tools is not only a matter of pride, but he also realizes the energy which may be saved and the

Workshop Practice

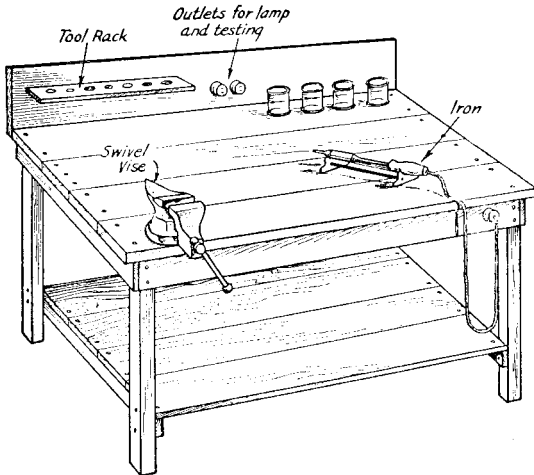

Fig. 702 — A work bench for the amateur shop. The legs are of 4-in. by 4-in. stock, the side rails and "junk shelf" of 1-in. boards and the top of 1¼-in. or 1½-in. planks. Three-eighths-inch carriage bolts should be used to secure the legs. The top may be covered with linoleum or similar material to present a more attractive appearance and to prevent screws and nuts from falling through the cracks between the boards.

annoyance which may be avoided by well kept sharp-edge tools. A few minutes with the oil stone or emery wheel now and then will maintain the fine cutting edges of knives, drills, chisels, etc.

Drills should be sharpened at frequent intervals so that grinding is kept at a minimum each time. This makes it easier to maintain the rather critical surface angles for best cutting with least wear. These angles are illustrated in Fig. 701.

The soldering iron may be kept in good condition by keeping the tip well tinned with solder and not allowing it to run at full voltage for long periods when it is not being used. After each period of use, the tip should be removed and cleaned of any scale, which may have accumulated. An oxidized tip may be cleaned by dipping in sal ammoniac while hot and wiping clean with a rag. Should the tip become pitted, it should be filed until smooth and then tinned by dipping it in solder.

All tools should be wiped occasionally with an oily cloth to prevent rust.

● WORK BENCH FOR THE AMATEUR SHOP

The sketch of a simple but satisfactory work bench is shown in Fig. 702. If space is available, it should be 6 to 9 feet long. Half-pint mayonnaise jars make excellent receptacles for screws, etc. They need not be labelled for the contents may be seen at a glance. Rubber stamp racks commonly sold in stationery stores make good holders for screwdrivers, etc.

● USEFUL MATERIALS

Small stocks of various miscellaneous materials will be required from time to time. Most of them may be purchased from hardware or radio-supply stores. A representative list follows:

½-in. by 1/16-in. brass strip for brackets, etc. (half-hard for bending)

¼-in. square brass rod or ½-in. by ½-in. by 1/16-in. angle brass for corner joints
¼-in. diam. round brass rod for shaft extensions

Machine screws: Round-head, flat-head with nuts to fit. Most useful sizes, 4-36, 6-32, and 8-32 in lengths from ¼-in. to 1½-in. (Nicked iron will be found satisfactory except in strong r.f. fields where brass should be used.)

Plain washers and lock washers for screws
Bakelite and hard rubber scraps

Soldering lugs, panel bearings, rubber grommets, lug terminal strips, cambric tubing

Machine screws, nuts, washers, soldering lugs, etc., are most reasonably purchased in quantities of a gross.

● CHASSIS AND PANELS

A definite plan should be followed in laying out and drilling a chassis and panel. Drill the mounting holes in the panel first and then clamp the panel to the chassis while drilling the mounting holes in the chassis. Before removing the panel, mark a clear line across the back of the panel along the top edge of the chassis for future reference.

Cover the top of the chassis with a piece of wrapping paper, or preferably cross-section paper, folding the edges down over the sides of the chassis and fastening with adhesive tape. Next, assemble parts to be mounted on top of the chassis and move them about until a satisfactory arrangement has been found, keeping in mind any parts which are to be mounted underneath so that interferences in mountings will be avoided. Place condensers and other parts with shafts extending to the panel first and arrange so that the controls will form the desired pattern on the panel. Be sure to line up the shafts square with the chassis front. Locate any partition shields and panel brackets next and then sockets with their shields, if used, and other parts, marking the mounting-hole centers of each, accurately, on the paper. Watch out for condensers whose shafts do not line up with the mounting holes. Do not forget to mark the centers of socket holes and holes for leads under i.f. transformers, etc., as well as holes for wiring leads.

By means of the square, lines indicating accurately the centers of shafts should be ex-

The Radio Amateur's Handbook

tended to the front of the chassis and marked on the panel at the chassis line by fastening the panel temporarily. The hole centers may now be punched in the chassis with the center punch and the paper removed for drilling and cutting holes. After drilling, the parts which require mounting underneath may be located and the mounting holes drilled, making sure by trial that no interferences exist with parts mounted on top. Mounting holes along the front edge of the chassis should be transferred to the panel by once again fastening the panel to the chassis and marking from the rear.

Next mount on the chassis the condensers and any other parts with shafts extending to the panel, and measure accurately the height of the center of each shaft above the chassis as illustrated in Fig. 703. The horizontal displacement of shafts having already been marked on the chassis line on the panel, the vertical displacement may now be measured from this line and the shaft centers marked on the back of the panel and the holes drilled. Holes for any other panel equipment coming above the chassis line may now be marked and drilled and the remainder of the apparatus mounted.

Drilling and Cutting Holes

In drilling holes in metal with the hand drill, it is important that the centers be well located with the center punch so that the drill point will not "walk" away from the center when starting the hole. Care should be used to prevent too much pressure with small drills which bend or break easily. When the drill starts to break through, special care should be used and it is often an advantage to shift a two-speed drill to low gear at this point. Holes near $\frac{1}{4}$ -in. in diameter may be started with a smaller drill and reamed out with a larger drill.

The chuck of the usual type of hand drill is limited to $\frac{1}{4}$ -in. drills. Although it is rather tedious, the $\frac{1}{4}$ -in. hole may be filed out to larger diameters with round files. Another possible method with limited tools is to drill a series of small holes with the hand drill along the inside of the diameter of the large hole,

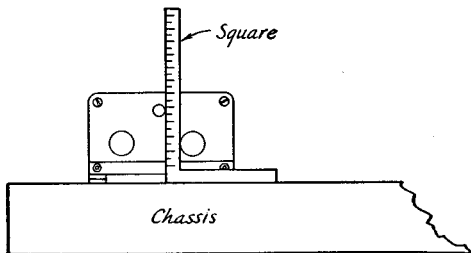

Fig. 703 — Method of measuring heights of shafts. If the square is adjustable, the end of the scale should be set flush with the face of the head.

placing the holes as close together as possible. The center may then be knocked out with a cold chisel and the edges smoothed up with a file. Taper reamers which fit in the carpenter's brace make the job much easier. A large rat-tail file may be clamped in the brace and makes a very good reamer for holes up to the diameter of the file if the file is revolved counter-clockwise.

For socket holes and other large round holes, an adjustable cutter designed for the purpose may be used in the brace. When the cutter is well sharpened, it makes the job easy. Occasional application of machine oil in the cutting groove usually helps. The cutter should first be tried out on a block of wood to make sure that it is set for the correct diameter. Probably the easiest device of all for cutting socket holes is

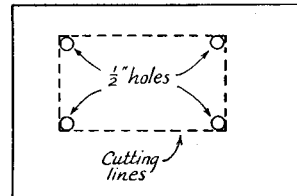

Fig. 704 — Cutting rectangular chassis holes. The hacksaw blade can be inserted in one of the four holes and then fastened in the hacksaw frame. The other holes can be used in turning the corners or in getting new starting points for the blade.

the socket-hole punch. The best type works by pressure applied by turning a screw with a wrench.

Square or rectangular holes may be cut out by using the series of small holes previously described, but more easily by drilling a $\frac{1}{2}$ -in. hole inside each corner, as illustrated in Fig. 704, and using these holes for starting and turning the hacksaw.

The burrs or rough edges which usually result in drilling or cutting holes may be removed with a file or sometimes more conveniently with a sharp knife or chisel. It is a good idea to keep an old wood chisel sharpened up for this purpose.

Cutting Threads

Brass rod may be threaded or the damaged threads of a screw repaired by the use of *dies*. Holes of suitable size (see drill chart) may be threaded for screws by means of *taps*. Either are obtainable in any standard machine-screw size. A set usually consists of taps and dies for 4-36, 6-32, 8-32, 10-32 and 14-20 sizes with a suitable holder for either tap or die. The die may be started easily by filing a sharp taper or bevel on the end of the rod. In tapping a hole, extreme care should be used to prevent breaking the tap. The tap should be kept at

Workshop Practice

NUMBERED DRILL SIZES

Number	Diameter (mils)	Will Clear Screw	Drilled for Tapping Iron, Steel or Brass*
1	228.0	—	—
2	221.0	12-24	—
3	213.0	—	14-24
4	209.0	12-20	—
5	205.0	—	—
6	204.0	—	—
7	201.0	—	—
8	199.0	—	—
9	196.0	—	—
10	193.5	10-32	—
11	191.0	10-24	—
12	189.0	—	—
13	185.0	—	—
14	182.0	—	—
15	180.0	—	—
16	177.0	—	12-24
17	173.0	—	—
18	169.5	8-32	—
19	166.0	—	12-20
20	161.0	—	—
21	159.0	—	10-32
22	157.0	—	—
23	154.0	—	—
24	152.0	—	—
25	149.5	—	10-24
26	147.0	—	—
27	144.0	—	—
28	140.5	6-32	—
29	138.0	—	8-32
30	128.5	—	—
31	120.0	—	—
32	116.0	—	—
33	113.0	4-36 4-40	—
34	111.0	—	—
35	110.0	—	6-32
36	106.5	—	—
37	104.0	—	—
38	101.5	—	—
39	099.5	3-48	—
40	098.0	—	—
41	096.0	—	—
42	093.5	—	4-36 4-40
43	089.0	2-56	—
44	086.0	—	—
45	082.0	—	3-48
46	081.0	—	—
47	078.5	—	—
48	076.0	—	—
49	073.0	—	2-56
50	070.0	—	—
51	067.0	—	—
52	063.5	—	—
53	059.5	—	—
54	055.0	—	—

* Use one size larger drill for tapping bakelite and hard rubber.

right angles to the surface of the material and rotation should be reversed a revolution or two whenever the tap starts to turn hard. With care, holes may be tapped rapidly by clamping the tap in the chuck of the hand drill and using slow speed. Machine oil applied to the tap usually makes cutting easier and sticking less troublesome.

Cutting and Bending Sheet Metal

If a sheet of metal is too large to be conveniently cut with a hacksaw, it may be marked with scratches as deep as possible along the line of the cut on both sides of the

sheet and then clamped in a vise and worked back and forth until the sheet breaks at the line. Do not carry the bending too far until the break begins to weaken, otherwise, the edge of the sheet may become bent. A pair of iron bars or pieces of heavy angle stock, as long or longer than the width of the sheet, used in the vise will make the job easier. "C" clamps may be used to keep the bars from spreading at the ends. The rough edges may be smoothed up with a file or by placing a large piece of emery cloth or sandpaper on a flat surface and running the edge of the metal back and forth over the sheet.

Bends are made similarly. The sheet should be scratched on both sides, but not too deeply.

Cleaning and Finishing Metal

Parts made of aluminum may be cleaned up and given a satin finish, after all holes have been drilled, by placing them in a solution of lye for half to three-quarters of an hour. Three or four tablespoonsful of lye should be used to each gallon of water. If more than one piece is treated in the same bath, each piece should be separated from the others so as to expose all surfaces to the solution. Overlapping of pieces may result in spots or stains.

Crackle Finish

Wood or metal parts may be given a crackle finish by applying one coat of clear Duco or Tri-Seal and allowing it to dry over night. A coat of Kem Art Metal Finish is then sprayed or put on thickly with a brush, taking care that the brush marks do not show. This should be allowed to dry for two or three hours and the part should then be baked in a household oven at 225 degrees for one and one-half hours. This will produce a regular commercial job. This finish comes in several different colors and is produced by the Sherwin-Williams Paint Co. and should be obtainable through any dealers handling Sherwin-Williams products.

● HOOK-UP WIRE

A popular type of wire for receivers and low-power transmitters is that known as "push-back" wire which comes in sizes of No. 18 or 20 which is sufficiently large for all power circuits except filament. The insulating covering, which is sufficient for circuits where voltages do not exceed 400 or 500, may be pushed back a few inches at the end making cutting of the insulation unnecessary when making a connection. Filament wires should be of sufficiently large conductor to carry the required current without appreciable voltage drop (see Wire Table, Chapter Twenty). Rubber-covered house wire sizes No. 14 to No. 10 is suitable for heavy-current transmitting tubes, while No. 18 to No. 14 flexible wire is satis-

The Radio Amateur's Handbook

factory for receivers and low-drain transmitting tubes where the total length of wire is not excessive.

Stiff bare wire, sometimes called *bus-wire*, is most favored for the high r.f.-potential wiring of transmitters and, where practicable, in receivers. It comes in sizes No. 14 and No. 12 and is usually tin-dipped. Soft-drawn antenna wire may also be used. Kinks or bends may be removed by stretching 10 or 15 feet of the wire and then cutting into small usable lengths.

The insulation covering power wiring which will carry high transmitter voltages should be appropriate for the voltage involved. Wire with rubber and varnished cambric covering, similar to ignition cable, is usually available at radio dealers. Smaller sizes have sufficient insulation to be safe at 1000 to 1500 volts, while the more heavily insulated types should be used for voltages above 1500.

● WIRING TRANSMITTERS AND RECEIVERS

It is usually advisable to do the power-supply wiring first. The leads should be bunched together in cable form as much as possible and kept down close to the surface of the chassis. Chassis holes for wires should be lined with *rubber grommets* to fit the hole to prevent chafing of the insulation. In cases where power-supply leads have several branches, it is often convenient to use *fibre terminal strips* as anchorages. These strips also form handy mountings for wire-terminal resistors, etc. When any particular unit is provided with a nut or thumb-screw terminal, solder-lug wire terminals to fit are useful.

High-potential r.f. wiring should be well spaced from the chassis or other grounded metal surfaces and should run as directly as possible between the points to be connected without fancy bends. When wiring balanced or push-pull circuits, care should be taken to make the r.f. wiring on each side of the circuit as symmetrical as possible. When it is necessary to pass r.f. wiring through the chassis, a *feed-through* insulator of low-loss material should be used, or the hole in the chassis should be of sufficient size to provide plenty of air space around the wire. Large-diameter rubber grommets may be used to prevent accidental short-circuit to the chassis.

By-pass condensers should be connected directly to the point to be by-passed and grounded immediately at the nearest available mounting screw, making certain that the screw makes good electrical contact with the chassis. In using tubular paper by-pass condensers, care should be taken to connect the "foil" side to ground.

Blocking and coupling condensers should be mounted well spaced from the chassis.

High-voltage wiring should be done in such a manner that exposed points are kept at a minimum and those which cannot be avoided are rendered as inaccessible as possible to accidental contact.

● SOLDERING

The secret of good soldering is in allowing time for the *joint*, not the solder, to attain sufficient temperature. Sufficient heat should be applied so that the solder will melt when it comes in contact with the wire forming the joint without the necessity of touching the solder to the iron. Soldering paste, if the non-corroding type, is extremely useful when used correctly. In general, it should not be used for radio work except when it is necessary to make the soldered joint with one hand. In this case, the joint should first be warmed slightly and the soldering paste applied with a piece of wire. Only the soldering paste which melts from the warmth of the joint should be used. If the soldering iron is clean, it will be possible to pick up a drop of solder on the tip of the iron which can be applied to the joint with one hand, while the other is used to hold the connecting wires together. The use of excessive soldering paste causes the paste to spread over the surface of adjacent insulation causing leakage or breakdown of the insulation. Except where absolutely necessary, solder should never be depended upon for the mechanical strength of the joint; the wire should be wrapped around the terminals or clamped with soldering terminals.

● CONSTRUCTION NOTES

Lockwashers should be used under nuts to prevent loosening with use, particularly when mounting tube sockets or plug-in coil receptacles subject to frequent strain.

If a control shaft must be extended or insulated, a flexible shaft coupling with adequate insulation must be used. Satisfactory support for the shaft extension may be provided by means of a *metal* panel bearing made for the purpose. Never use panel bearings of the non-metal type unless the condenser shaft is grounded. *The metal bearing should be connected to the chassis with a wire or grounding strip.* This prevents any possible danger

● COIL CEMENT

Duco cement, obtainable universally at hardware, stationery or five-and-ten-cent stores, is a very satisfactory substance for fastening coil turns. For small coils, however, it is rather thick and a better-looking job will result if it is thinned out with acetone, amyl acetate sometimes referred to as banana oil. If desired, the solution may be made thin enough to permit application with a brush.

Construction of Receivers

Regenerative Receivers — Low-Cost Superhet Designs — Converters — Beat Oscillators — Preselection — Antenna Tuning

THE home-built receiver has strong competition to meet in the greatly-diversified line of receiving equipment now available from a number of manufacturers, especially on a cost basis. The question of whether to buy or build is, therefore, not easily decided. However, the satisfaction that comes from having built one's own receiver, plus more ready willingness to experiment, as new ideas come along to be tried, with the product of one's own hands than with a factory-made outfit, are two reasons in favor of home construction. This is especially true with the simpler types of set. It must be admitted that the average manufactured receiver of the more elaborate variety is characterized by a much higher order of mechanical construction than is possible with simple tools in the home workshop.

The receivers described in this chapter have been built upon the principle of obtaining maximum performance per dollar of cost. They are all relatively inexpensive to build. Free use is made of regeneration to obtain gain and selectivity with a small number of tubes and circuits. This means that much of the success of the receiver depends upon the skill of the operator in bringing its inherent performance capabilities to realization. This skill can easily be acquired with a little practice, and once acquired the operator can rest assured that his results compare favorably with those obtained from much more expensive equipment.

The receivers described here do not include power-supply equipment. It is best not to attempt to build the receiver and power supply on the same chassis, since considerable care is needed to prevent hum from either electrical or mechanical shortcomings. The power supply requirements are given, and the supply itself may be constructed from the data in Chapter 11.

● A TWO-TUBE REGENERATIVE RECEIVER

The simplest receiver capable of giving satisfactory results in everyday operation is one consisting of a regenerative detector plus a single audio amplifier for headphone output. Figs. 801-805, inclusive, show a two-tube receiver of this type which is well suited for duplication by beginners. Since dry-battery

tubes as well as those intended for operation from the a.c. line may be used in it, it is also a thoroughly practical portable receiver as well. Light-weight dry "A" and "B" batteries will furnish power for it with excellent life.

The circuit diagram is given in Fig. 803. Socket connections for both battery and a.c. tubes are the same, although if a.c. tubes are to be used exclusively the screen-grid connection shown in the audio stage may be omitted, while if battery tubes only are to be used the cathode resistor, R_3 , and by-pass condenser, C_9 , in the audio amplifier can be left out.

The receiver is built on a 7 by 7 by 2 inch metal chassis. The top view of the set shows clearly how the parts are arranged on the base and panel. The sockets for the two tubes and the power-supply plug (at the rear) project through the base. Each hole should be just large enough to pass the socket — about $1\frac{1}{8}$ inches in diameter — and the centers should be $2\frac{5}{8}$ inches back from the panel and $1\frac{1}{4}$ inches in from the edges of the chassis.

The coil socket is midway between the two tube sockets and is also $2\frac{5}{8}$ inches behind the panel. This socket is supported by two $1\frac{1}{2}$ -inch

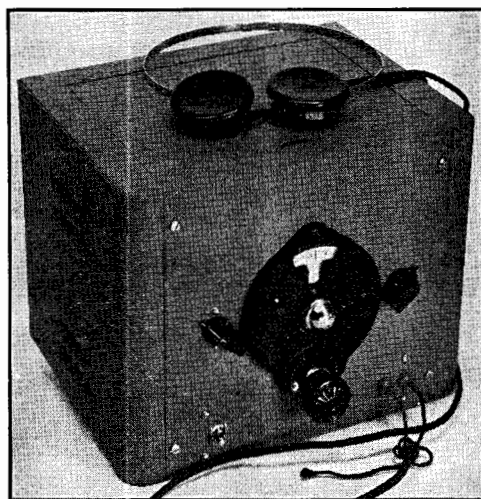

Fig. 801 — The receiver mounted in its cabinet and ready for use.

The Radio Amateur's Handbook

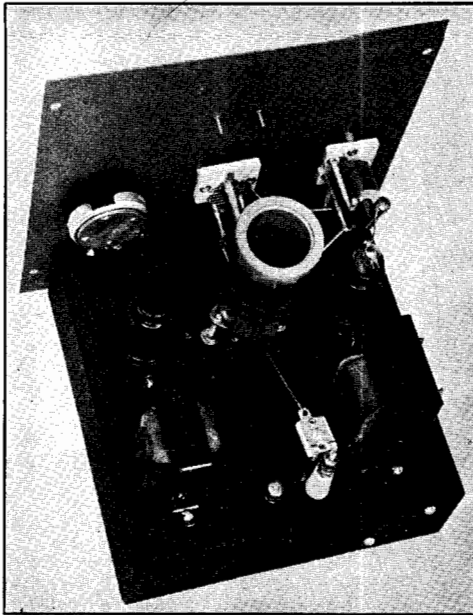

Fig. 802 — A top-of-chassis view of the two-tube regenerative receiver.

6-32 bolts. The socket ring is held firmly on the head end of the bolts by tightening nuts on the under side of the ring, and the bolts are then run through holes in the chassis and held firmly by nuts and washers on both sides. If small brass pillars are available to slip over the bolts, they can be added for some slight additional strength.

The coil socket is mounted with the two large holes facing towards the right-hand side of the set (looking at the receiver from the front) and the tube sockets are mounted with the notches on the centering holes towards the panel. The orientation of supply-plug socket is immaterial. Holes in the chassis for leads from E and F on the coil socket are made large enough to accommodate small rubber grommets which in-

sulate the wires running through the holes from the metal. A soldering lug is fastened under the supporting bolt adjacent to the hole under B, and the wire from B solders to this lug to form a ground connection.

The antenna terminal is made from a small porcelain stand-off pillar, secured to the base by a bolt from the underside, and a bolt is screwed in at the top of the pillar (after the head of the bolt has been sawed off) and locked in place by a nut. The antenna condenser, C_3 , is then slipped over the bolt and held in place by another nut. Two washers are then slipped on the bolt and a final nut completes the assembly, which swerves as a support for the condenser and also as the antenna binding post. The ground post is made from a bolt through the baseboard which has a convenient soldering lug held in place by a washer and the bottom nut. The paint should be scraped from the chassis so that the lug makes good electrical contact.

The choke L_4 and the transformer T_1 are held in place by bolts, and holes are drilled in the base for the wires from these components.

The arrangement of parts on the panel will become clear after inspection of the front and top views. The condensers C_1 and C_2 are supported on the panel by bolts fastening to the mounts provided on the condensers. Large holes are drilled to clear the shafts. The dial is fastened by the three screws provided for the purpose, and it should be centered carefully so that there is no tendency towards binding, which might keep the dial from working smoothly.

The panel measures 8 inches by $8\frac{1}{4}$ inches and is the one furnished with the cabinet. The band-set condenser, C_2 , and the regeneration control, R_4 , are $2\frac{3}{4}$ inches away from the main tuning condenser, C_1 , so that the knobs will clear the edge of the dial. C_1 is placed in the center of the panel and the switch, Sw , and the phone tip jacks are centered under C_2 and R_4 respectively, at a height of 1 inch from the bottom of the panel.

TWO-TUBE RECEIVER COIL TABLE

No.	Range, Mc.	Amateur Band, Mc.	Turns			Dimensions, Inches					Band Spread Tap
			L_1	L_2	L_3	a	b	c	d	e	
1	1.55-3.0	1.75	$48\frac{3}{4}$	$13\frac{1}{2}$	13 (28)	$1\frac{1}{8}$	$\frac{1}{8}$	$\frac{3}{8}$	$\frac{1}{8}$	$\frac{3}{8}$ ($\frac{3}{4}$)	—
2	2.8-6.5	3.5	$22\frac{3}{4}$	$10\frac{1}{2}$	$8\frac{1}{2}$ ($20\frac{1}{2}$)	$\frac{3}{8}$	$\frac{1}{8}$	$\frac{1}{4}$	$\frac{1}{8}$	$\frac{1}{4}$ ($\frac{1}{2}$)	—
3	5.0-10.5	7.0	$15\frac{3}{4}$	$7\frac{1}{2}$	$5\frac{1}{2}$ ($12\frac{1}{2}$)	$\frac{7}{8}$	$\frac{1}{4}$	$\frac{1}{4}$	$\frac{1}{8}$	$\frac{1}{8}$ ($\frac{3}{8}$)	7
4	7.5-16.5	14.0	$9\frac{3}{4}$ ($8\frac{3}{4}$)	$4\frac{1}{2}$	$5\frac{1}{2}$ ($5\frac{1}{2}$)	$\frac{7}{8}$	$\frac{1}{4}$	$\frac{1}{8}$	$\frac{1}{4}$	$\frac{1}{8}$ (—) ($\frac{3}{4}$)	$2\frac{1}{2}$
5	16.0-33.0	28.0	3	$3\frac{1}{4}$	$2\frac{1}{4}$	$\frac{1}{2}$	$\frac{1}{4}$	$\frac{1}{4}$	—	$\frac{1}{8}$	1 (not recommended)

All coils are wound with No. 24 d.s.c. wire. The taps are counted off from the lower end of L_1 (connection B); coils No. 1 and 2 are not tapped and terminal D goes directly to C inside the coil form. All L_1 's are space-wound except on coil No. 1; all L_2 's and L_3 's are close-wound except on coil No. 5, where L_3 is space-wound within L_1 .

Construction of Receivers

The remaining receiver parts are mounted underneath the chassis. They can be identified readily in Fig. 804. Although the exact placement of parts is not critical, the general arrangement shown should be followed, since it results in short radio-frequency leads and also lends itself to convenient wiring.

Connections in the tuning circuit (between the variable condensers and the coil socket) are made with bus wire as shown in Fig. 802. A wire from the rotor of C_2 goes to the rotor of C_1 and thence to B on the coil socket. Another wire from B goes through the base and over to the No. 2 pin of the detector socket. Finally, a wire from B is run to the ground binding post at the rear of the set.

The grid condenser, C_4 , and the grid leak, R_1 , are mounted on the stator terminal of C_2 , being soldered directly to the lug. Thus only a short connection is needed to run to the grid cap of the tube and there is little tendency to pick up hum from nearby power wires.

Pieces of bus wire are used to connect the stators of the tuning condensers to the proper coil socket terminals, and another piece of the wire is used from F on the coil socket to the screen-grid pin (No. 4) of the detector socket. The rest of the connections are made with smaller "push-back" wire.

Of the three wires from the variable resistor, R_4 , the one from the right-hand side (looking at it from the back) goes to the ground bus, the center one runs over to one side of C_5 , and the third terminal connects to switch Sw through R_5 . Connected in this manner, turning the knob clockwise will increase the screen voltage and consequently the feedback.

In connecting C_9 , be sure the "plus" terminal goes to the No. 8 pin on the amplifier tube socket. The "minus" terminal should connect to the common ground wire. If this connection is not made properly, the condenser will not function correctly and may be damaged.

The rest of the wires are placed in convenient

positions, and a study of Fig. 804 will furnish a clear picture of how to run the leads. The sequence of the connections on the power-plug socket is of no importance. The switch, Sw , in the positive B lead, is necessary so that the battery plate supply will not be wasted during transmission periods. The heater or filament power, which is left on during any operating period, is most conveniently disconnected at the source, whether it be battery or transformer.

Coil data are given in the table and should be followed closely as a start. When starting to wind a coil, first solder one end of the wire in the proper pin, after threading the wire through a small hole in the coil form. Then secure the distant end of the wire (after unwinding from the spool as much wire as is judged necessary for the coil) to a doorknob or other convenient point, and wind the coil by stretching the wire taut and walking towards the far end of the wire as the coil form is revolved in the hand. This will wind the wire tightly on the form and result in a much better-looking coil

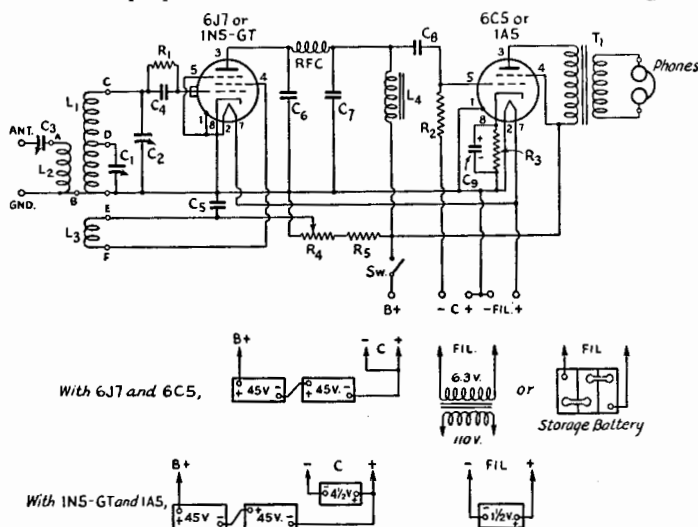

Fig. 803 — Wiring diagram of the two-tube receiver.

- C_1 — 35- μ fd. midget variable (Millen 20035 or Hammarlund HF-35).
- C_2 — 100- μ fd. midget variable (Millen 20100 or Hammarlund HF-100).
- C_3 — 3-30- μ fd. mica trimmer condenser (Millen 26030, Hammarlund MEX or National M30).
- C_4 — 100- μ fd. midget mica.
- C_5 — 0.5- μ fd., 400-volt paper.
- C_6, C_7 — 0.0005- μ fd. midget mica.
- C_8 — 0.01- μ fd., 600-volt paper.
- C_9 — 10- μ fd., 25-volt electrolytic.
- R_1 — 2-megohm, 1-watt carbon.
- R_2 — 0.5-megohm, $\frac{1}{2}$ -watt carbon.
- R_3 — 1000-ohm, $\frac{1}{2}$ -watt carbon.
- R_4 — 25,000-ohm wire-wound potentiometer.
- R_5 — 15,000-ohm, 1-watt carbon.
- L_1, L_2, L_3 — See Fig. 805 and coil table.
- L_4 — 500-henry audio choke (Thordarson T76C46).
- T_1 — Audio transformer (Thordarson T13A34).
- Sw — Single-pole single-throw toggle switch.
- RFC — 2.5-mh. radio-frequency choke.

The Radio Amateur's Handbook

than if the form is held and the wire wrapped around. When the proper number of turns has been wound on the form, the wire is cut a foot from the form and this end threaded through the proper hole and pin in the form. The insulation is then scraped from the end of the wire brought through the pin, and the wire is soldered to the pin. The important thing is to wind on the wire evenly and as tightly as possible. In the case of spaced turns, the wire is wound on first by spacing the turns by eye and, after the ends have been soldered, the turns can be moved slightly to give more even spacing, or string can be wound between the turns and then unwound.

Taps are made on L_1 by drilling a small hole in the form at the proper point (after the coil has been wound and properly spaced), scraping the insulation on the wire for a very small distance either side of the hole, and soldering the end of a short length of wire to the scraped portion.

After the set is completed and the wiring checked to make sure that it is exactly as shown, insert the No. 3 coil (selected because signals can usually be heard in this range at any time of the day or night) in the coil socket and connect the headphones, antenna and ground, and the heater supply. The heater supply, as well as the plate power, is conveniently connected by means of a 5-wire cable and a 5-prong plug which fits into the socket at the rear of the set. After the heater supply has been connected for a few minutes, the metal tubes should feel warm to the touch; the dry-battery tubes heat up instantly but there is no detectable sign that they are on. If the tubes do not warm up, the wiring should be checked. The "B" battery

(and "C," if needed) can now be connected and the switch, Sw , closed. The switch is closed when the toggle is pointing towards the side of the switch from which the terminals are brought out.

Now turn the regeneration control knob in a clockwise direction until the set goes into oscillation. This phenomenon is easily recognizable by a distinct click, thud or hissing sound. The point where oscillation just begins is the most sensitive operating point at that particular dial setting.

The tuning dial may now be slowly turned, the regeneration control knob being varied simultaneously (if necessary) to keep the set just oscillating. A number of stations will probably be heard. A little practice will make tuning easy.

If the set refuses to oscillate, the sensitivity will be poor and no code signals will be heard on the frequencies at which such signals should be expected. It should oscillate easily, however, if the coils are made exactly as shown and the tubes and batteries are good. It sometimes happens that the antenna takes so much energy from the set that it cannot oscillate, this usually resulting in "holes" in the range where no signals can be picked up (and where the hissing sound cannot be obtained). This can be cured by reducing the capacity of C_3 (unscrewing the adjusting screw) until the detector again oscillates. If it still refuses to oscillate, the coil L_3 must be moved nearer to L_2 or, in extreme cases, a turn or two must be added to L_3 . This is best done by rewinding with more turns rather than by trying to add a turn or two to the already-wound coil. For any given band of frequencies, adjust C_3 (and possibly L_3) so that

the detector oscillates over the whole range, using as much capacity at C_3 as is possible. This will give the best compromise between dead spots and signal strength. It will be found that less advancing of the regeneration control, R_4 , is required at the high-frequency end of a coil range (C_2 at or near minimum capacity) than at the low-frequency range. Since it is desirable to have the detector go into oscillation with the regeneration control advanced well towards its maximum, the best adjustment of the antenna condenser, C_3 , and the feedback coil, L_3 , is that which requires almost a maximum setting of the regeneration control at the low-frequency end (maximum capacity of C_2) of any coil range.

Coil No. 1 just misses the high-frequency end of the broadcast band, but it is possible to hear

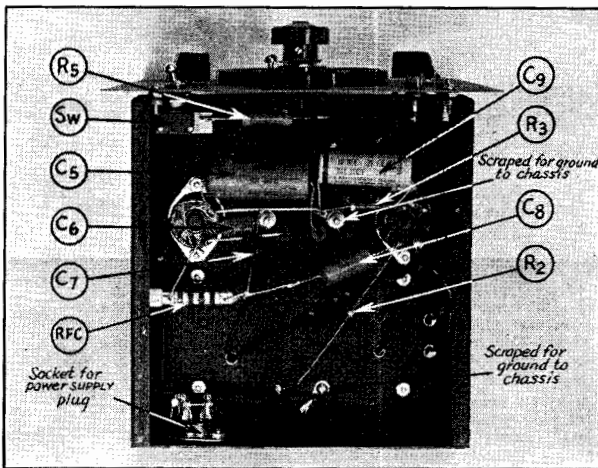

Fig. 804 — The underside of the two-tube receiver chassis, showing how the panel is spaced away from the chassis (necessary only when a cabinet is used).

Construction of Receivers

police stations and the 160-meter amateur band with it, as well as other services. The amateur band is most easily located by listening at night (when there is the most activity), setting C_1 at maximum and slowly tuning with C_2 until some of the police stations are heard. These stations operate on 1712 kc., so that once found they become "markers" for the low-frequency end of the band. Further tuning then should be done with the main tuning dial, and many amateur stations should be heard. The band-set condenser setting will work out to be about 70% to 80% fully meshed, for the 160-meter amateur band.

Locating the amateur bands on the other coils is done in much the same manner, by searching carefully with C_2 . The 3.5-4.0-Mc. amateur band will be found on coil No. 2 at about 65% setting of C_2 ; it will be easiest to locate this band by setting C_1 at minimum capacity (plates unmeshed) and adjusting C_2 until amateur 'phone stations are heard. Again this is best done at night, when the activity is heaviest on this band. On coil No. 3, the 7-Mc. amateur band will be found with C_2 meshed about 45%; the 14- and 28-Mc. bands are found with C_2 meshed about 20% and 15% respectively.

Since a regenerative receiver is particularly susceptible to hum troubles when operated with a rectified a.c. plate supply, a 90-volt "B" battery (two 45-volt blocks in series) is recommended for this purpose.

A suitable antenna for the receiver would be 50 to 75 feet long, and as high and clear of surrounding objects as possible. The ground lead should preferably be short; a ground to a heating radiator or any of the water piping is good. (*Bib. 1.*)

● A THREE-TUBE GENERAL COVERAGE AND BAND-SPREAD SUPERHET

A superhet type receiver can be constructed almost as simply as a regenerative detector set, but is of course capable of a much higher order of performance especially on the lower frequencies where image response is not serious. An example of such a receiver is given in Figs. 806-810. The circuit uses a minimum number of tubes for good performance, and gives continuous frequency coverage from about 75 kc. (4000 meters) to 60 Mc. (5 meters). Provision is made for spreading each of the amateur bands over most of the tuning dial. The receiver is intended for operation from either a 6.3-volt transformer or 6-volt storage battery for filament supply, and a 90-

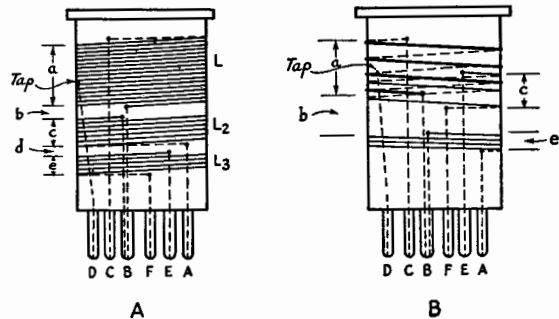
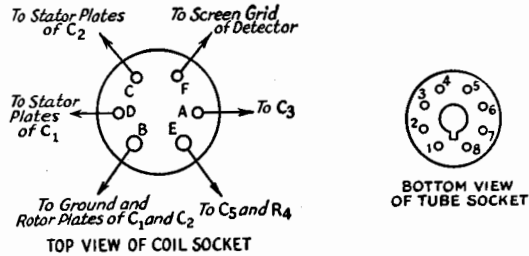

Fig. 805 — Tube and socket connections for the receiver. All of the coils except No. 5 for metal tubes and No. 4 for battery tubes are wound as at A; B shows how coil No. 5 for metal tubes and No. 4 for battery tubes are wound. All coils for any one range must be wound in the same direction. In the table (p. 110) the values given in parentheses apply only to the battery-tube coils, otherwise the values are the same for both types of tubes.

volt "B" battery for plate supply. It can therefore be used either as an inexpensive station receiver or for portable work when a car battery is available.

The circuit diagram is given in Fig. 807. A 6K8 is used as a combined oscillator-mixer, followed by a 6SK7 i.f. amplifier. The intermediate frequency is 1600 kc., a frequency which reduces image response on the higher frequencies and simplifies the design for low-frequency operation in the region below the broadcast band. One section of the 6C8G double triode is used as a second detector and the other section as a beat-frequency oscillator. Headphone output is taken from the plate circuit of the second detector.

To simplify construction and eliminate padding condensers on each plug-in coil, the antenna circuit is not ganged with the oscillator, but must be separately tuned to resonance with the incoming signal if maximum signal strength is desired. The input tuning control, C_1 , may be used as a volume control by detuning from resonance.

The mixer grid circuit, L_1C_1 , is tuned to the signal frequency; L_2 is the antenna coupling coil. The oscillator circuit, $L_3C_2C_3$, is tuned 1600

The Radio Amateur's Handbook

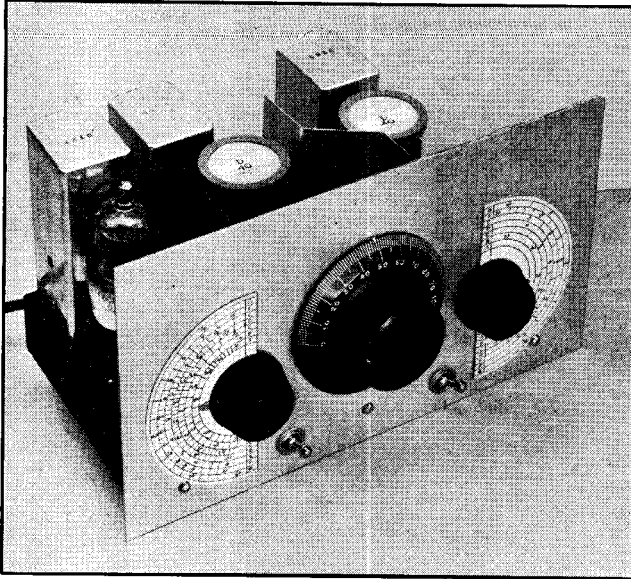

Fig. 806 — The three-tube superhet, designed for either a.c. or d.c. heater operation and 90-volt "B" battery plate supply.

kc. higher than the signal on frequencies up to 5 Mc.; above 5 Mc. the oscillator is 1600 kc. lower than the signal to improve stability. The resonant circuit is in the plate of the oscillator and a tickler in the grid circuit provides the feedback for oscillation. C_2 is the general coverage or band-setting condenser, C_3 the band-spread or tuning condenser. C_4 is a tracking condenser which sets the oscillator tuning range

on each band so that it coincides with the tuning range in the mixer grid circuit

The i.f. stage uses interstage-type transformers at both T_1 and T_2 ; these are permeability-tuned units with silvered-mica fixed padding condensers. The second detector is cathode-biased by R_4 , with C_{11} a by-pass for audio frequencies. The plate by-pass condenser, C_{12} , helps cut down high-frequency response and thus reduces hiss.

The second 6C8G section is the beat oscillator, using a permeability-tuned transformer made for the purpose. The grid condenser and leak are built into the transformer. The plate is fed through the b.o. on-off switch and a dropping resistor, R_5 , the latter serving both to reduce the "B" current drain and to cut down the output of the oscillator to a value suitable for good heterodyning. No special coupling is needed between the beat oscillator and the second detector; there is enough stray coupling between the two sections of the tube to introduce the beat frequency into the detector circuit.

The plates and screens of all tubes except the beat oscillator are operated at the same voltage — 90 volts. The "B" current drain is approximately 15 milliamperes, which is about

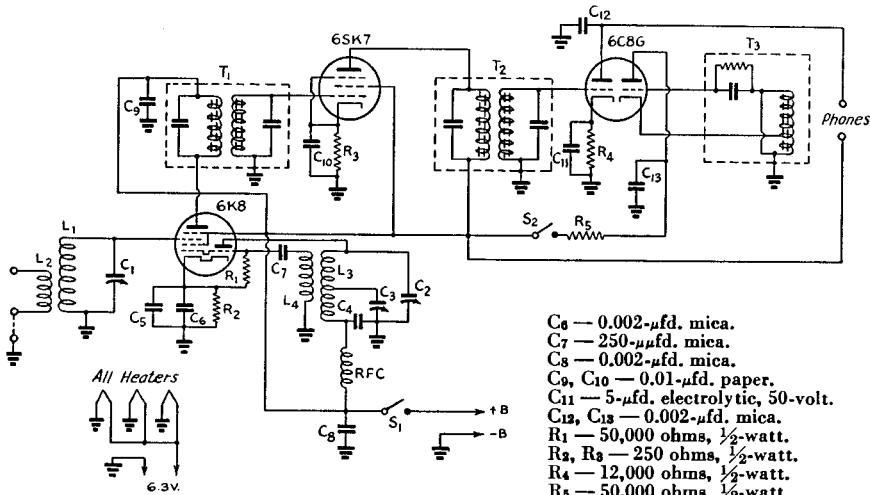

Fig. 807 — The three-tube superhet wiring diagram.
 C_1 — 140- μ fd. variable (Hammarlund MC-140-M).
 C_2 — 100- μ fd. variable (Hammarlund MC-100-M).
 C_3 — 35- μ fd. variable (Hammarlund HF-35).
 C_4 — Oscillator padder; see coil table.
 C_5 — 0.1- μ fd. paper.

C_6 — 0.002- μ fd. mica.
 C_7 — 250- μ fd. mica.
 C_8 — 0.002- μ fd. mica.
 C_9, C_{10} — 0.01- μ fd. paper.
 C_{11} — 5- μ fd. electrolytic, 50-volt.
 C_{12}, C_{13} — 0.002- μ fd. mica.
 R_1 — 50,000 ohms, $\frac{1}{2}$ -watt.
 R_2, R_3 — 250 ohms, $\frac{1}{2}$ -watt.
 R_4 — 12,000 ohms, $\frac{1}{2}$ -watt.
 R_5 — 50,000 ohms, $\frac{1}{2}$ -watt.

T_1, T_2 — 1600-kc. permeability-tuned i.f. transformer, interstage type (Sickles 9282).
 T_3 — 1600-kc. beat oscillator transformer (Sickles 9127).
 L_1, L_2, L_3, L_4 — See coil table.
 S_1, S_2 — S.p.s.t. toggle switch.
 RFC — 2.5-mh. r.f. choke.

Construction of Receivers

COIL DATA FOR THE THREE-TUBE SUPERHET

Range	Turns					C ₄
	L ₁	L ₂	L ₃	L ₄	L ₃ Tap	
A — 76-154 kc.....	30 mh.	1 mh.	65	12	Top	300 μ fd.
166-360 kc.....	8 mh.	1 mh.				
400-1500 kc.....	2.5 mh.*	*				
B—1.6 to 3.2 Mc. (160).....	56	10	42	11	Top	75 μ fd.
C — 3.00 to 5.7 Mc. (80).....	32	8	27	9	Top	100 μ fd.
D — 5.4 to 10.0 Mc. (40).....	18	8	22	9	12	0.002 μ fd.
E — 9.5 to 18 Mc. (20).....	10	8	12	3½	6	400 μ fd.
F — 15.0 to 30 Mc. (10).....	6	4	6	2½	2½	400 μ fd.
G — 30 to 60 Mc. (5).....	3	3	3½	1	1	300 μ fd.

* See Fig. 810 and text for details. C₄ is mounted inside oscillator coil form; see Fig. 810. Band-spread taps on L₃ measured from bottom (plus-B end) of coil. L₃-A and L₁-B coils close-wound with No. 22 enamelled wire; L₃-B close-wound with No. 20 enamelled; all other grid coils (L₁ and L₃) wound with No. 18 enamelled, spaced to give a length of 1½ inches on a 1½-inch diameter form (Hammarlund SWF) except the G coils, which are spaced to a length of 1 inch on 1-inch diameter forms (Millen 45004 and 45005). Antenna and plate coils, L₂ and L₄, are close-wound with No. 24 enamelled, spaced about one-eighth inch from bottoms of grid coils, except for L₄-G, which is interwound with L₃.

the normal drain for medium-size "B" batteries. The receiver will operate satisfactorily, but with somewhat reduced volume, with a single 45-volt battery for "B" supply.

The parts arrangement is shown in the photographs of Figs. 808 and 809. The chassis is 5½ by 9½ by 1½ inches. The panel, made from a piece of aluminum, is 10½ inches wide and 6 inches high. The mixer tuning condenser, C₁, is at the right, band-spread tuning condenser C₃ in the center, controlled by the National Type A 3½-inch dial, and the band-set condenser, C₂, at the left. The on-off switches for the "B" supply and the beat oscillator are mounted on the front edge of the chassis as shown.

Referring to the top view, Fig. 808, the i.f. section is along the rear edge, with T₁ at the right. Next is the socket for the 6SK7, then T₂ and finally T₃ at the extreme left. The socket for the 6C8G is just in front of T₃. The triode section with the grid brought out to the top cap is used for the beat oscillator.

The r.f. section has been arranged for short leads to favor high-frequency operation. The three sockets grouped closely together in the center are, from left to right, the oscillator coil socket, socket for the 6K8, and the mixer coil socket. All are mounted above the chassis by means of mounting pillars, so that practically all r.f. leads are above deck. The oscillator grid leak, R₁, and the high-frequency cathode by-pass condenser, C₆, should be mounted directly on the socket before it is installed. So also should the oscillator grid condenser, C₇, which can

be seen extending to the left toward the oscillator coil socket in Fig. 808. Power supply connections should be soldered to the 6K8 socket prongs before the socket is mounted, and these leads brought down through a hole in the chassis.

C₁ and C₂ are mounted directly on the chassis. C₃ is held from the panel by means of a small bracket made from metal strip, bent so that the condenser shaft lines up with the dial coupling. A shield made of aluminum separates the oscillator and mixer sections; this shield is essential to prevent coupling between the two circuits which might otherwise cause interaction and poor performance.

The first step in putting the receiver into operation is to align the i.f. amplifier. This should preferably be done with the aid of a test oscillator, but if one is not available the circuits may be aligned on hiss or noise. The beat oscillator can also be used to furnish a signal for

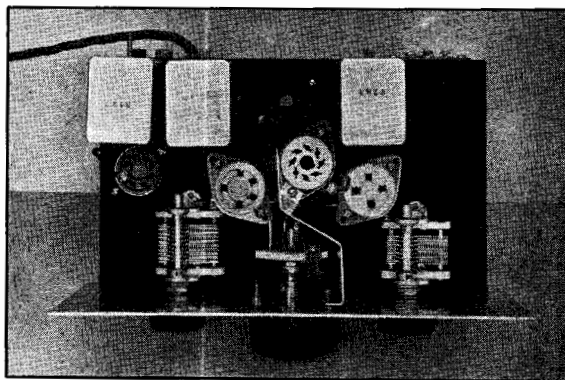

Fig. 808 — A plan view of the three-tube superhet with the coils and tubes removed.

The Radio Amateur's Handbook

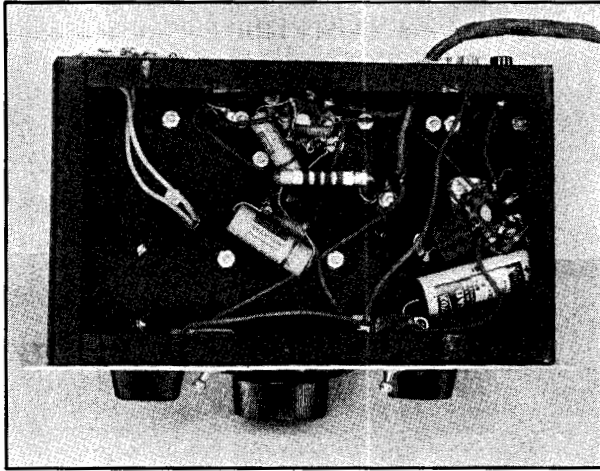

Fig. 809 — Below the chassis of the three-tube receiver. The r.f. choke is mounted near the oscillator coil socket to keep the r.f. leads short. In the i.f. stage, care should be taken to keep the plate and grid leads from the i.f. transformer short and well separated. A four-wire cable is used for power supply connections. The phone tip jacks are in the upper right corner.

alignment. Further information on alignment may be found in Chapter 9.

The coils are wound as shown in Fig. 810. A complete set of specifications is given in the coil table, but the builder can make only those covering frequencies in which he is interested if preferred. Ordinary windings are used for all oscillator coils, and for all mixer coils for frequencies above 1600 kc. Below 1600 kc., readily available r.f. chokes are used for the tuned circuits. For the broadcast band and the 600-750-meter ship-to-shore channels, the mixer coil is a Hammarlund 2.5-mh. r.f. choke, with the pies tapped as shown in Fig. 810. The grid end and the intermediate tap are connected to machine screws mounted near the top of the coil form, and a flexible lead is brought out from the grid pin in the coil form to be fastened to either lead as desired. Mixer coils for the two lowest-frequency ranges are constructed as shown. The antenna winding in each case is a coil taken from an old 465-kc. i.f. transformer, having an inductance of about 1 millihenry. The inductance is not particularly critical, and a pie from a 2.5-mh. choke may be used instead.

With the i.f. aligned, the detector and oscillator coils for a band can be plugged in. C_3 should be set near minimum and C_2 tuned from minimum until a signal is heard. Then C_1 is adjusted for maximum signal strength. If C_2 is set at the high-frequency end of an amateur band, further tuning should be done with C_3 , and the band should be found to cover about 75 per cent of the dial. C_3 can of course be used for band-spread tuning outside the amateur bands. It is convenient to calibrate the receiver, using home-made paper scales for the

purpose as shown in Fig. 806. Calibration points may be taken from incoming signals of known frequency, from a calibrated test oscillator, or from harmonics of a 100-kc. oscillator as described in Chapter 17. The mixer calibrations need only be approximate, since tuning of the mixer circuit has little effect on the oscillator frequency. It is sufficient to make a calibration which ensures that the mixer is tuned to the desired signal rather than the image.

On the broadcast band, the tuning range is such that with C_2 set at 1500 kc. the entire band will be covered on C_3 . It is necessary, however, to change the tap on the mixer coil to make the antenna circuit cover the entire band. Only one oscillator coil is needed for the complete range from 75 to 1500 kc., because of the rather high intermediate frequency, but a series

of coils is needed to cover the same range in the mixer circuit.

The sensitivity of the receiver on 56 Mc. is

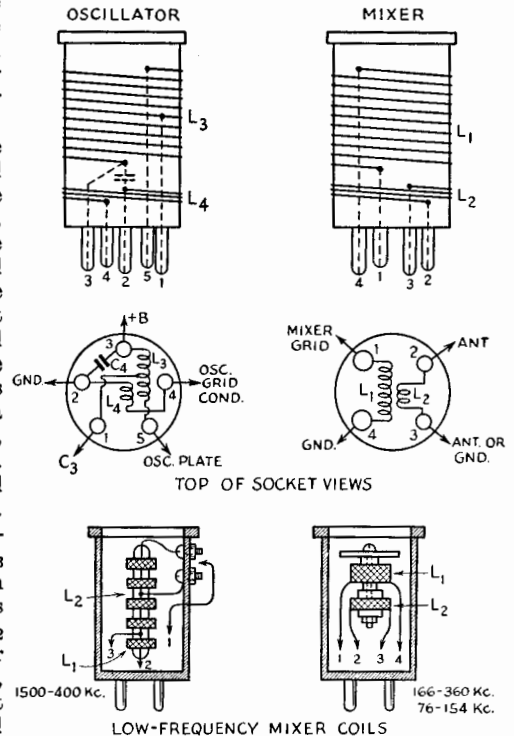

Fig. 810 — How the coils for the three-tube superhet are constructed. On the hand-wound coils, all windings are in the same direction.

Construction of Receivers

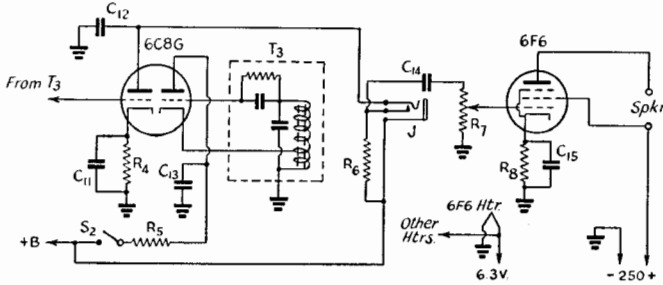

Fig. 812 — Pentode audio amplifier for the three-tube superhet. Except as noted below, components correspond to those bearing similar numbers in Fig. 807.

- C₁₄ — 0.1- μ d. paper
- C₁₅ — 25- μ d. electrolytic, 50-volt
- R₆ — 120,000 ohms, $\frac{1}{2}$ -watt
- R₇ — 500,000-ohm volume control
- R₈ — 400 ohms, 1-watt
- J — Closed-circuit jack

not as good as on the lower frequencies, or as would be expected from a receiver laid out primarily for ultra-high-frequency operation, but is sufficient for occasional listening on this band.

Adding an Audio Stage to the Three-Tube Superhet

Very frequently the builder of a small receiver wishes it to operate a loud speaker. The three-tube receiver just described is designed for headphone operation, but readily can be converted to a four-tube set for use with a speaker. For this purpose a 6F6 pentode can be added to the circuit diagram as shown in Fig. 812. There is ample chassis space for installation of the additional tube. Figs. 811 and 813 show how the receiver looks when completed.

For the purpose of driving the audio stage, resistance coupling is used from the plate of the second detector to the grid of the 6F6. A volume control is used for the grid resistor of the 6F6, and a jack installed in the second detector plate circuit so that a headphone plug may be inserted. The volume control, R_7 , should be the midget type so that it will fit in the chassis, and is installed with its control projecting under the tuning dial. In the bottom view, Fig. 813, the 6F6 socket is in the upper left corner, along with the cathode resistor and by-pass condenser, R_8 and C_{15} . The coupling condenser, C_{14} , and plate resistor, R_6 , are mounted on an insulated lug strip near the volume control.

The 6F6 will require a plate supply of 250 volts at about 40 milliamperes. This may be taken from a regular power pack, and a five-wire connection cable is used to provide an extra lead for the purpose. The first three tubes may be operated from a "B" battery as before. Alternatively, the power supply may be constructed with a tap giving 90 or 100 volts for these tubes, the tap being connected to the proper wire in the connection cable. For best performance, the output voltage of such a tap should

be regulated by a VR-105-30 regulator tube.

The primary winding of the speaker output transformer always should be connected in the plate circuit of the 6F6 when the tube is being fed "B" voltage. Operating without the plate circuit closed is likely to damage the screen. Any speaker having a transformer with primary impedance of 7000 ohms will be satisfactory; a permanent-magnet dynamic is convenient since no field supply is necessary.

For portable work the 6F6 may be removed from the receiver and the three tubes used on batteries as previously described.

● A REGENERATIVE SINGLE-SIGNAL RECEIVER

An inexpensive amateur-band receiver of relatively simple construction, using i.f. regeneration for single-signal reception, is shown in Fig. 814. Fig. 815 gives the circuit diagram. Regeneration is used in the mixer circuit to improve the signal-to-image ratio and to give added gain.

The mixer, a 6SA7, is coupled to the antenna and is separately excited by a 6J5 oscillator. There is a single 460-kc. i.f. stage, using a

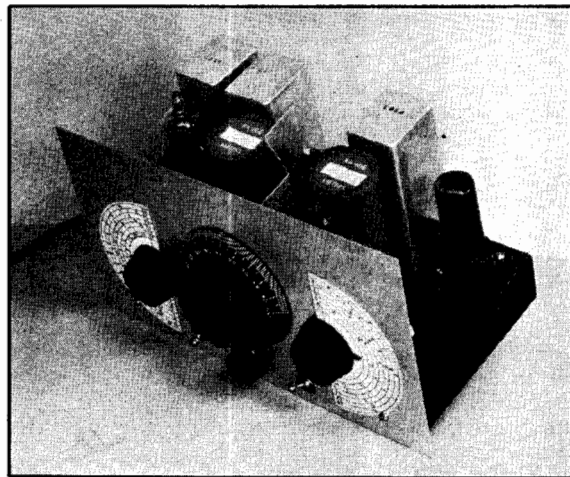

Fig. 811 — The audio amplifier tube installed on the chassis of the three-tube receiver.

The Radio Amateur's Handbook

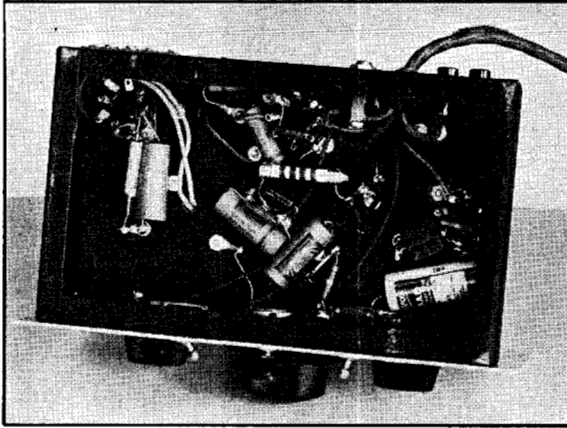

Fig. 813 — Additional parts for the audio output stage can readily be identified in this sub-chassis view of the receiver.

6SK7 and permeability-tuned transformers. The second detector and first audio amplifier is a 6SQ7 and the audio output tube for loud-speaker operation is a 6F6. The separate beat oscillator circuit uses a 6C5. A VR-105 voltage regulator tube is used to stabilize the plate voltage on the oscillators and the screen voltage on the mixer and i.f. tubes.

To make construction easy and to avoid the necessity for additional trimmer condensers on each coil, the mixer and high-frequency oscillator circuits are separately tuned. Main tuning is by the oscillator band-spread condenser, C_3 , which is operated by the calibrated dial. C_2 is the oscillator band-setting condenser. The mixer circuit is tuned by C_1 , and regeneration in this circuit is controlled by R_{15} , connected across the mixer tickler coil, L_3 .

R_{16} is the i.f. amplifier gain control, which also serves as an i.f. regeneration control when this stage is made regenerative. C_{15} is the regeneration condenser; it is adjusted to feed back a small amount of i.f. energy from the plate to the grid of the 6SK7 and thus produce oscillation. If the high selectivity afforded by i.f. regeneration is not wanted, C_{15} may be omitted.

Diode rectification is used in the second detector circuit. One of the two diode plates in the 6SQ7 is used for developing a.v.c. voltage, being coupled through C_{22} to the detector diode. The detector load resistor consists of R_5 and R_7 in series, the tap being used for r.f. filtering of the audio output to the triode section of the tube. R_{18} is the a.v.c. load resistor; R_9 , C_{14} and C_{12} constitute the a.v.c. filter circuit. S_2 cuts the a.v.c. out of circuit by grounding the recti-

fier output. The headphones connect in the plate circuit of the triode section of the 6SQ7; R_{17} is the audio volume control.

The top and bottom views, Figs. 816 and 817, show the layout quite clearly. The chassis is 11 by 7 by 2 inches and the panel 7 by 12 inches, both standard sizes. The band-spread tuning condenser, C_3 , is at the front center; at the left is C_1 , the mixer tuning condenser; and at the right, C_2 , the oscillator band-set condenser. The oscillator tube is directly behind C_3 , with the mixer tube to the left on the other side of a baffle shield which separates the two r.f. sections. This shield, measuring $4\frac{1}{4}$ by $4\frac{1}{2}$ inches, is used to prevent coupling between oscillator and mixer. The mixer coil socket is at the left edge of the chassis behind C_1 ; the oscillator coil socket is between C_2 and C_3 .

The i.f. and audio sections are along the rear edge of the chassis. The transformer in the rear left corner is T_1 ; next to it is the i.f. tube, then T_2 . Next in line is the 6SQ7, followed by the 6C5 beat oscillator, the b.o. transformer, T_3 and finally the 6F6. The VR-105 is just in front of T_3 . The i.f. transformers should be mounted with their adjusting screws projecting to the rear where they are easily accessible.

The controls along the bottom edge of the panel are, from left to right, the mixer regeneration control, R_{15} , the i.f. gain control, R_{16} , the audio volume control, R_{17} , and the beat-oscillator vernier condenser, C_{21} . The latter has

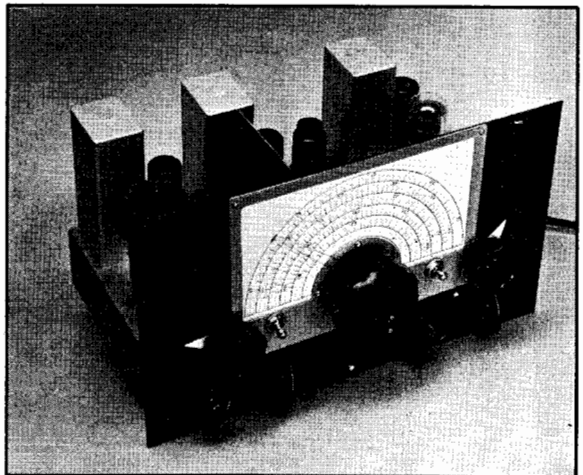

Fig. 814 — A 7-tube superhet using regeneration to give single-signal reception and improve image ratio. The dial (National ANC) may be directly calibrated for each amateur band.

Construction of Receivers

the corner of one rotary plate bent over so that when the condenser plates are fully meshed the condenser is short-circuited, thus stopping oscillation.

The tube heaters are all in parallel, one side of each being grounded right at the tube socket. Only one filament wire need be run from tube to tube.

The beat oscillator is coupled to the second detector by the small capacity formed by running an insulated wire from the grid of the 6C5 close to the detector diode plate prong on the 6SQ7 socket. Very little coupling is needed for satisfactory operation.

In wiring the i.f. amplifier, keep the grid and plate leads from the i.f. transformers fairly close to the chassis and well separated. Without C_{15} , the i.f. stage should be perfectly stable and should show no tendency to oscillate at full gain.

The method of winding the coils is shown in Fig. 818 and complete specifications are given in the coil table. Ticklers (L_3) for the mixer

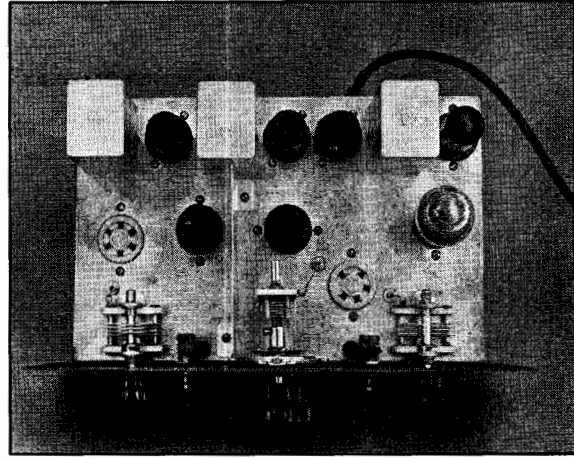

Fig. 816 — Top view of the 7-tube superhet without coils in place. Placement of parts is discussed in the text.

circuit are scramble-wound to a diameter which will fit readily inside the coil form and mounted on stiff leads going directly to the

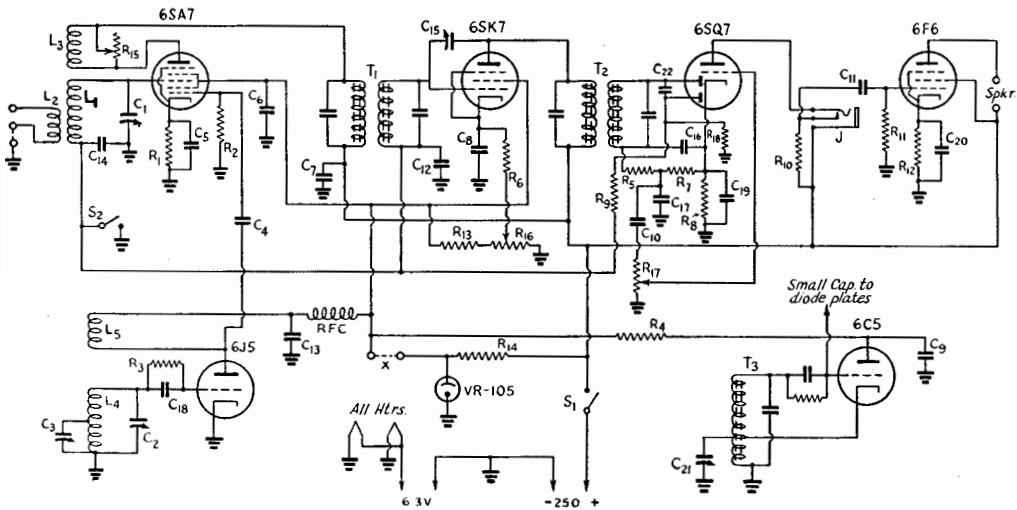

Fig. 815 — Circuit diagram of the regenerative superhet.

- C_1, C_2 — 50- μ fd. variable (Hammarlund MC-50-S).
- C_3 — 35- μ fd. variable (National UM-35).
- C_4 — 50- μ fd. mica.
- C_5, C_6, C_7, C_8 — 0.1- μ fd. paper, 600-volt.
- $C_9, C_{10}, C_{11}, C_{12}$ — 0.01- μ fd. paper, 600-volt.
- C_{13}, C_{14} — 0.005- μ fd. mica.
- C_{15} — 3-30- μ fd. trimmer (National M-30); see text.
- C_{16} — 250- μ fd. mica.
- C_{17}, C_{18}, C_{22} — 100- μ fd. mica.
- C_{19}, C_{20} — 25- μ fd. electrolytic, 50-volt.

- C_{21} — 25- μ fd. variable (Hammarlund SM-25).
- R_1 — 200 ohms, $\frac{1}{2}$ -watt.
- R_2 — 20,000 ohms, $\frac{1}{2}$ -watt.
- R_3, R_4, R_5 — 50,000 ohms, $\frac{1}{2}$ -watt.
- R_6 — 300 ohms, $\frac{1}{2}$ -watt.
- R_7 — 0.2 megohm, $\frac{1}{2}$ -watt.
- R_8 — 2000 ohms, $\frac{1}{2}$ -watt.
- R_9 — 1 megohm, $\frac{1}{2}$ -watt.
- R_{10} — 0.1 megohm, $\frac{1}{2}$ -watt.
- R_{11} — 0.5 megohm, $\frac{1}{2}$ -watt.
- R_{12} — 450 ohms, 1-watt.
- R_{13} — 75,000 ohms, 1-watt.
- R_{14} — 5000 ohms, 10-watt adjustable.
- R_{15} — 10,000-ohm volume control.
- R_{16} — 25,000-ohm volume control.

- R_{17} — 2-megohm volume control.
- R_{18} — 2-megohms, $\frac{1}{2}$ -watt.
- T_1 — 460-kc. permeability-tuned i.f. transformer, interstage type (Millen 64456).
- T_2 — 460-kc. permeability-tuned i.f. transformer, diode type (Millen 64454).
- T_3 — 460-kc. beat-oscillator transformer (Millen 64546).
- RFC — 2.5-mh. r.f. choke.
- J — Closed-circuit jack.
- S_1, S_2 — S.p.a.t. toggle.
- L_1-L_5 , inc. — See coil table.
- X indicates jumper inside VR-105 base.

The Radio Amateur's Handbook

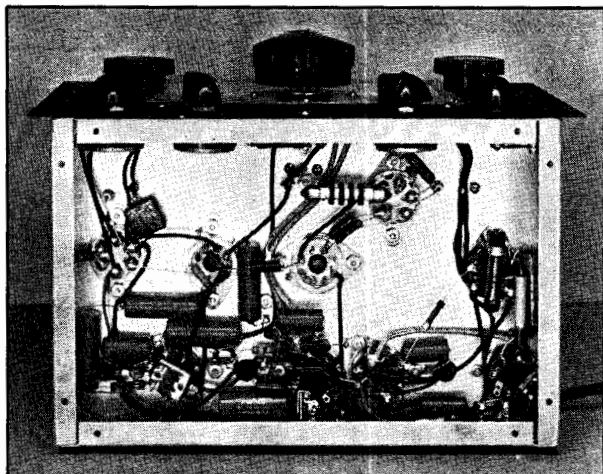

Fig. 817 — The below-chassis wiring is shown in this view of the 7-tube receiver.

proper pins in the form. The leads should be long enough to bring the coils inside the grid winding at the bottom. The amount of feedback is regulated by bending the tickler coil with respect to the grid coil. Maximum feedback is secured with the two coils coaxial, minimum when the tickler axis is at right angles to the axis of L_1 . The position of L_3 should be adjusted so that the mixer goes into oscillation with R_{15} set at $\frac{1}{2}$ to $\frac{3}{4}$ maximum resistance.

The oscillator circuit has been adjusted to make the proper value of rectified grid current flow in the 6SA7 injection grid (No. 1) circuit on each amateur band. This calls for a fairly strong feedback, with the result that if the band-set condenser is set toward the high-frequency end of its range the oscillator may "squeg." This is of no consequence unless the receiver is to be used for listening outside the amateur bands, in which case it may be corrected by taking a few turns off the tickler coil, L_5 , but at some sacrifice of conversion efficiency in the amateur band for which the coil was designed.

The i.f. amplifier can be aligned most conveniently with the aid of a modulated test oscillator. First alignment should be made with C_{15} disconnected so that the performance of the amplifier non-regenerative can be checked. A headset or loud speaker can be used as an output indicator. The mixer and oscillator coils should be out of their sockets, and R_{15} should be set at zero resistance.

Connect the test oscillator output across C_1 , which should be set at minimum capacity. Adjust the test oscillator frequency to 460 kc. and, using a modulated signal, adjust the trimmers on T_1 and T_2 for maximum volume. R_{16} should be set for maximum gain, and the

beat oscillator should be off. As the circuits are brought into line, reduce the oscillator output to keep from overloading any of the amplifiers, which might cause a false indication.

After the i.f. is aligned, plug in a set of coils for some band on which there is a good deal of activity. Set the oscillator padding condenser, C_2 , at approximately the right capacity; with the coil specifications given, the proportion of total C_2 capacity on each band will be about as follows: 1.75 Mc., 90 per cent; 3.5 Mc., 75 per cent; 7 Mc., 95 per cent; 14 Mc., 90 per cent; 28 Mc., 45 per cent. Set the mixer regeneration control, R_{15} , for minimum regeneration — no resistance in circuit. Connect an antenna. Switch the beat oscillator on by turning C_{21} out of the maximum position,

and adjust the screw on T_3 until the characteristic beat-oscillator hiss is heard.

Now tune C_1 slowly over its scale, starting from maximum capacity. Using the 7-Mc. coils as an example, when C_1 is at about half scale there should be a definite increase in noise and in the strength of the signals which may be heard. Continue on past this point until a second peak is reached on C_1 ; at this peak the input circuit is tuned to the frequency which represents an image in normal reception. The oscillator in the receiver is designed to work on the high-frequency side of the incoming signal, so that C_1 always should be tuned to the peak which occurs with most capacity.

After the signal peak on C_1 has been identified, tune C_3 over its whole range, following with C_1 to keep the mixer circuit in tune, to see how the band fits the dial. With C_2 properly set, the band edges should fall the same number of main dial divisions from 0 and 100; if the band runs off the low-frequency edge, less capacity is needed at C_2 , while the converse is true if the band runs off the high edge. Once the band is properly centered on the dial, the panel may be marked at the appropriate point so that C_2 may be reset readily when changing bands.

To check the operation of the mixer regeneration, tune in a signal on C_3 , adjust C_1 for maximum volume, and slowly advance the regeneration control, R_{15} . As the resistance increases retune C_1 to maximum, since the regeneration control will have some effect on the mixer tuning. As regeneration is increased, signals and noise will both become louder and C_1 will tune more sharply. Finally the mixer circuit will break into oscillation when, with C_1 right at resonance, a loud carrier will be heard

Construction of Receivers

since the oscillations generated will go through the receiver in exactly the same way as an incoming signal. As stated before, oscillation should occur with R_{15} set at half to three-quarters full scale. In practice, always work with the mixer somewhat below the critical regeneration point and never permit it actually to oscillate. On the lower frequencies, where images are less serious, the tuning is less critical if the mixer is non-regenerative. In this case, always set R_{15} at zero since there will be a range on the resistor where, without definite regeneration, the signal strength will be less than it is with zero resistance.

Should the mixer fail to oscillate, adjust the coupling by changing the position of L_3 with respect to L_1 . If the coil happens to be "poled" incorrectly, the circuit will not oscillate. This can be cured by rotating L_3 through 180 degrees. It is best to test the mixer regeneration first with the antenna off, since loading effects may give misleading results until it is known that L_3 is properly set to produce oscillation.

After the preceding adjustments have been completed the i.f. regeneration may be added. Install C_{15} , taking out the adjusting screw and bending the movable plate to make an angle of about 45 degrees with the fixed plate. Realign the i.f. As the circuits are tuned to resonance the amplifier will oscillate, and each time this happens the gain control, R_{16} , should be backed off until oscillations cease. Adjust the trimmers to give maximum output with the lowest setting of R_{16} . At peak regeneration the

COIL TABLE					
Band	Coil	Wire Size	Turns	Length	Tap
1.75 Mc.	L_1	24	70	Close-wound	—
	L_2	24	15	" "	—
	L_3	22	15	—	—
	L_4	22	42	Close-wound	Top
	L_5	24	15	" "	—
3.5 Mc.	L_1	22	35	" "	—
	L_2	22	9	" "	—
	L_3	22	12	—	—
	L_4	22	25	1 inch	18
	L_5	22	10	Close-wound	—
7 Mc.	L_1	18	20	1 inch	—
	L_2	22	5	Close-wound	—
	L_3	22	9	—	—
	L_4	18	14	1 inch	6
	L_5	22	6	Close-wound	—
14 Mc.	L_1	18	10	1 inch	—
	L_2	22	5	Close-wound	—
	L_3	22	7	—	—
	L_4	18	7	1 inch	2.4
	L_5	22	4	Close-wound	—
28 Mc.	L_1	18	4	1 inch	—
	L_2	22	4	Close-wound	—
	L_3	22	1.5	—	—
	L_4	18	3.6	1 inch	1.4
	L_5	22	2.4	Close-wound	—

All coils except L_3 are $1\frac{1}{2}$ inches in diameter, wound with enamelled wire on Hammarlund SWF Forms. Spacing between L_1 and L_2 , and between L_4 and L_5 , approximately $\frac{1}{2}$ inch. Band-spread taps are measured from bottom (ground) end of L_4 .

L_3 for 28 Mc. is interwound with L_1 at the bottom end. L_3 for all other coils is self-supporting, scramble-wound to a diameter of $\frac{3}{4}$ inch, mounted inside the coil form near the bottom of L_1 .

signal strength should be about the same, despite reduced gain in the amplifier, as without regeneration at full gain. Too much gain with regeneration will have an adverse effect on selectivity.

For single-signal c.w. reception, set the beat oscillator so that when R_{16} is advanced to make the i.f. just go into oscillation the resulting tone is the desired beat-note frequency. Then back off on R_{16} to obtain the desired degree of selectivity. Maximum selectivity will be secured with the i.f. just below the oscillating point. The "other side of zero beat" will be very much weaker than the desired side.

A useful feature of the band-spread dial is that it can be directly calibrated in frequency for each band. These calibrations may be made with the aid of a 100-kc. oscillator such as described in Chapter 17. Ten-kc. points may be plotted if a 10-kc. multivibrator is available, but since the tuning is almost linear in each band a fairly accurate plot will result if each 100-kc. interval is simply divided off into ten equal parts.

Power supply requirements for the receiver are 2.2 amp. at 6.3 volts for the heaters and 80 ma. at 250 volts for the plates. Without the pentode output stage a supply giving 6.3 volts at 1.5 amp. and 250 volts at 40 ma. will be sufficient. (*Bib. 2.*)

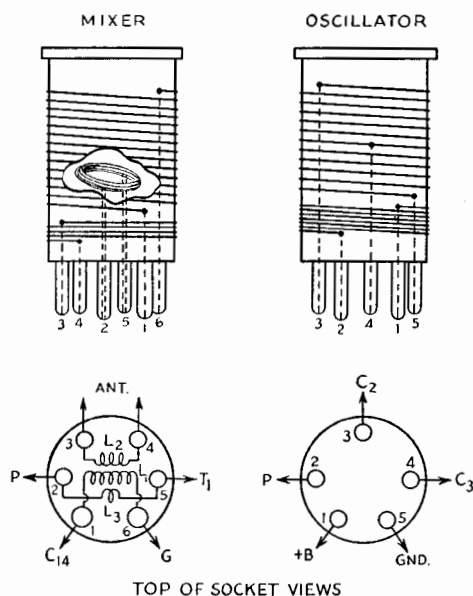

Fig. 818 — Coil and socket connections for the 7-tube superhet.

The Radio Amateur's Handbook

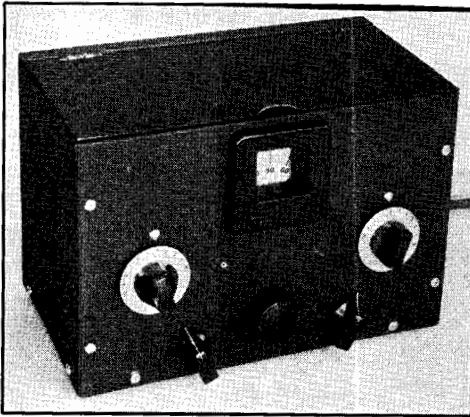

Fig. 819 — Front view of the converter. The hand-spread knob is at the center with the band-set and detector tuning condensers to the right and left, respectively. The antenna and on-off switches are to the left and right at the bottom of the panel.

● A ONE-TUBE CONVERTER

Rather than building a complete receiver, some amateurs prefer to use a "converter" in conjunction with an ordinary broadcast receiver. The converter is simply a superhet mixer and oscillator with its output circuit arranged to feed into the antenna terminals of the broadcast receiver. By this method the gain and selectivity of the broadcast receiver are used, and an amateur-band receiver can be obtained at relatively little expense. A converter also is useful with a regular communications receiver which has a low-frequency (460 kc. or lower) i.f., because the converter output frequency may be made considerably higher — of the order of 1600 kc. — with a consequent improvement in image ratio on the higher-frequency amateur bands such as 14 and 28 Mc. A single-tube converter for this type of operation is shown in Figs. 819–824 inclusive.

Fig. 820 shows the circuit diagram of the converter. A 6K8 functions as the mixer-oscillator tube. L_1 and C_1 form the mixer tuned circuit and $L_2C_2C_3$, the oscillator portion of the 6K8. C_3 may be tapped across the coil for band-

spread to suit the individual's choice; the taps suggested in the coil chart give approximately 90-division spread with the dial used. A separate tickler winding provides feed-back for the oscillator. T_1 is the output transformer.

Nearly all the parts are mounted on an $8\frac{1}{2}$ by $4\frac{3}{4}$ by $1\frac{1}{2}$ -inch chassis. Those remaining, C_1 , C_2 and the dial assembly, mount on the panel of a 9 by 5 by 6 inch cabinet. The top view, Fig. 822 shows the positions of the components when mounted. C_3 is elevated above the chassis by metal pillars which allow the condenser shaft and assembly to be properly aligned. To insure short r.f. leads the tube and coil sockets are supported on pillars also. The heater prongs of the tube socket face the rear of the chassis. Holes $1\frac{1}{4}$ inches in diameter are drilled below the sockets so the prongs can be reached easily by a soldering iron.

The by-pass condensers, resistors and switches are below the base as shown in bottom view, Fig. 823. Output and power leads are soldered to lug strips fastened in place by the socket and output transformer screws and nuts.

The two switches on the front wall of the

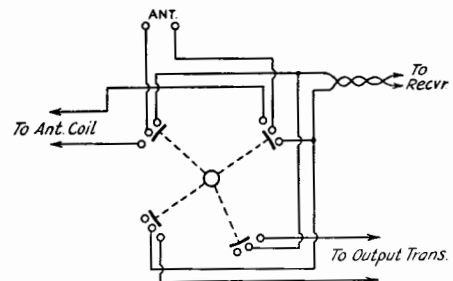

Fig. 821 — The converter antenna switch wiring diagram.

chassis should be mounted before the panel is attached. Each switch should have an extra nut screwed to the shaft; this provides a small space between the chassis and panel when the two are fastened together, and the front edge of the bottom plate slips into this space when the cabinet is assembled. The panel and chassis are held firmly together by a third nut on each switch shaft.

Fig. 820 — Wiring diagram of the single-tube converter.

C_1 , C_2 — 100- μ fd. midget variable (Millen 20100).

C_3 — 35- μ fd. midget variable (Millen 20035).

C_4 , C_5 — 0.1- μ fd., 400-volt.

C_6 — 0.01- μ fd., 400-volt.

R_1 — 300 ohms, $\frac{1}{2}$ -watt.

R_2 — 50,000 ohms, $\frac{1}{2}$ -watt.

R_3 — 20,000 ohms, 10-watt.

Sw_1 — S.p.s.t. switch.

Sw_2 — 4-pole double-throw switch (Yaxley 3242J).

T_1 — Output transformer (Miller 512 WT).

Dial assembly (Millen 10011).

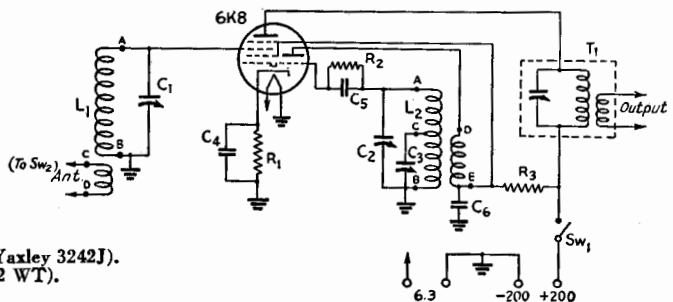

Construction of Receivers

Fig. 821 shows how Sw_2 is wired. This switch shifts the antenna from the converter to the receiver.

Coils L_1 and L_2 are wound on 1-inch diameter forms with the associated antenna and tickler coils wound approximately $\frac{1}{8}$ inch below the main windings. Fig. 824 shows the construction. The spacing between windings is not too important and in the case of the 1.75-Mc. mixer coil will have to be slightly less than suggested, because the form will not handle all of the turns otherwise.

A 200-250-volt receiver power supply may be used with the converter. The heater requirements are 6.3 volts at 0.3 amperes. It is also possible to tie into the b.c. or communication receiver supply if it is capable of standing the extra 10 or 12 ma. "B" drain that the 6K8 will impose upon it. A portable supply consists of a 6-volt storage battery and two or three 45-volt "B" blocks. For automobile operation it is assumed that the car battery and b.c. receiver supply will be employed.

The unit may be tested after the chosen power supply has been connected. The antenna and converter output leads are connected in place first. Power is then applied and the receiver turned on. The band-setting condenser, C_2 , is set at half scale and the receiver is tuned to a frequency between 1400-1600 kc. The

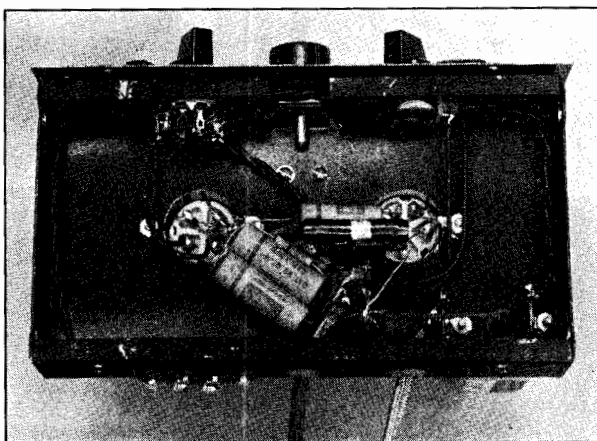

Fig. 823 — Bottom view of the converter. Only a few components are below the chassis.

noise level as heard in the receiver output may be used as a tuning indicator with which to peak up the converter output circuit. The transformer is tuned with an insulated screwdriver and proper peaking will be indicated by an increase in noise.

The oscillator band-spread condenser is used to tune in signals after a band has once been located on the band-set condenser. The mixer circuit tuning is quite broad and, as a result, it is not necessary to reset C_1 each time the oscillator circuit is tuned. During the preliminary adjustments the condenser may be left at half scale unless the noise level is sufficiently low to warrant peaking to the highest point attainable. For regular work the circuit need be retuned not more than three or four times across each band.

A signal generator or amateur signals of known frequency may be used to line up the converter. In all cases it will be found that the low-frequency end of an amateur band comes with C_2 adjusted to approximately half scale. The band-spread condenser, C_3 , should be at nearly maximum capacity during the lining up procedure. Because only part of the band-set condenser capacity is required to tune to the amateur bands it is possible to use the converter for general coverage by setting this condenser to higher or lower capacity values.

In using the converter with a broadcast receiver some provision to attain the effect of a beat oscillator must be made for c.w. reception. This may be done by setting the receiver or i.f. system to the frequency of a weak

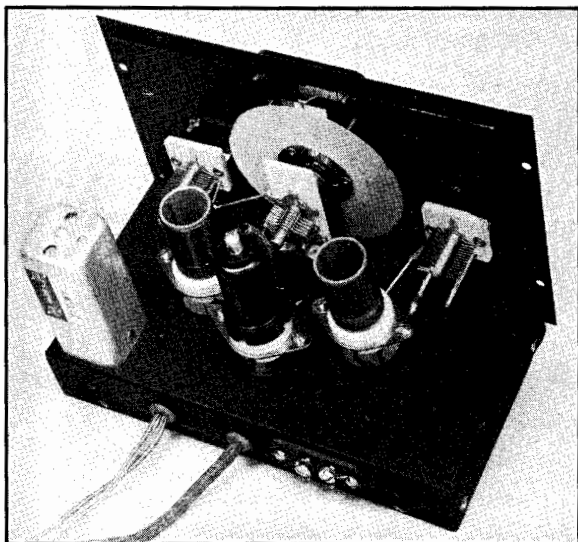

Fig. 822 — Top view of the converter. L_1 and L_2 are to the right and left of the 6K8. The output transformer stands at the left. The power-cable output leads and antenna terminals may be seen along the rear wall of the chassis.

The Radio Amateur's Handbook

broadcast station carrier. This must be done before the converter is lined up. A preferable method is to use a separate beat oscillator such as is described in the subsequent section.

If more or less band-spread than the specified coils give is desired, it is only necessary that the band-spread tap be moved toward the grid

getting a beat note for c.w. reception, as mentioned in the previous section. The most satisfactory way to get such a beat frequency is by means of a beat-oscillator unit. The beat oscillator may be constructed quite simply and at little expense. Fig. 825 shows such an oscillator.

The circuit diagram is shown in Fig. 826. Plate voltage is fed to the 6C5 through R_1 . C_1 is the plate by-pass condenser. The grid leak and condenser are included in the transformer. An adjustable condenser shown on the diagram at the right of the coil is used to set the oscillator frequency to the receiver intermediate frequency; the condenser at the left of the coil is the b.f.o. control. C_2 , the coupling condenser, is the capacity existing between the shielded output lead and the receiver i.f. or second detector circuit. The lead is not connected to either of these stages but is simply placed near enough to the transformer or tube socket for sufficient coupling.

A chassis measuring $3\frac{1}{2}$ by $2\frac{1}{2}$ by $1\frac{1}{4}$ inches, bent from a piece of 1/16-inch aluminum, is used as the base. The tube and transformer mount on top and the remaining parts mount below as shown in Figs. 825 and 827. Fig. 827 shows the power cable and output lead coming out through holes in the rear wall of the chassis. Holes may be drilled in the front wall so the unit may be bolted to the receiver proper.

Most broadcast superhets have intermediate frequencies in the vicinity of 456-465 kc. so that an oscillator transformer such as that specified will be satisfactory in the majority of

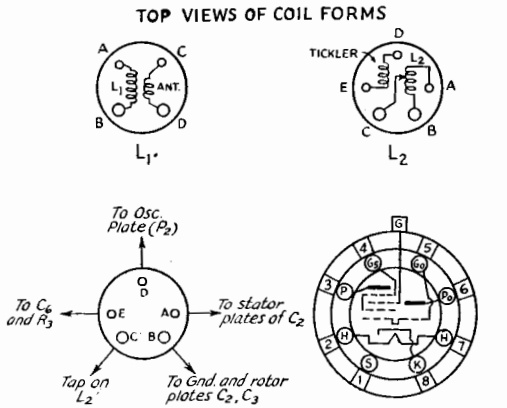

Fig. 824 — Socket and coil-form pin arrangement for the converter coils.

end of the coil for less spread, or toward the ground end for more. (Bib. 3.)

● BEAT OSCILLATOR FOR BROADCAST RECEIVERS

When a converter is used with a broadcast receiver, some provision must be made for

CONVERTER COIL DATA

Band	Coil	Turns	Wire	Length	Antenna Coil	Tickler	Band-Spread Tap *
1.75 Mc.	L ₁	65	28 d.s.c.	Close-wound	14 turns No. 28 d.s.c.		
	L ₂	45	22 enam.	Close-wound		15 turns No. 28 d.s.c.	26
3.5 Mc.	L ₁	38	22 enam.	Close-wound	7 turns No. 22 enam.		
	L ₂	60	28 d.s.c.	Close-wound		15 turns No. 28 d.s.c.	**
7 Mc.	L ₁	21	22 enam.	$\frac{7}{8}$ in.	5 turns No. 22 enam.		
	L ₂	23	22 enam.	Close-wound		5 turns No. 22 enam.	$11\frac{1}{4}$
14 Mc.	L ₁	8	22 enam.	$\frac{3}{4}$ in.	3 turns No. 22 enam.		
	L ₂	7	22 enam.	$\frac{3}{4}$ in.		4 turns No. 22 enam.	$2\frac{3}{4}$
28 Mc.	L ₁	3	22 enam.	$\frac{1}{2}$ in.	2 turns No. 22 enam.		
	L ₂	3	22 enam.	$\frac{1}{2}$ in.		2 turns No. 22 enam.	$1\frac{1}{4}$

All coils wound on 1-inch forms (Millen 45004 for L₁, 45005 for L₂).
 Antenna and tickler coils are close-wound approximately $\frac{1}{4}$ inch below L₁, L₂.
 * Turns counted off from ground end of coil.
 ** No band-spread tap; jumper placed between prongs, of coil form.

Construction of Receivers

● A 14- AND 28-MC. PRESELECTOR

A separate preselector unit, consisting of an r.f. amplifier which may be inserted between the antenna and receiver, is an extremely useful device. Its use is especially beneficial on the 14- and 28-Mc. bands where image response becomes bothersome with superhet receivers using intermediate frequencies of the order of 455 kc., since the added selectivity practically wipes out the image. Also, the gain of most receivers drops off on these two bands as compared with the lower frequencies, so that the additional gain of the preselector is helpful in building up the weaker signals to more substantial volume.

A simple preselector for these two bands is shown in Figs. 828 and 830. As shown in the circuit diagram, Fig. 829, the amplifier tube is an 1852, with tuned grid and plate circuits. The tuning condensers, C_1 and C_2 , are ganged for single-control tuning.

The unit is built on a 7 by 7 by 2-inch chassis. Fig. 828 shows the arrangement of parts on top. The grid-circuit coil is at the left rear corner, with the 1852 directly in front of it. An L-shaped shield partition separates the grid circuit from the plate coil, L_3 , which is in the right front corner. The sockets for both coils are

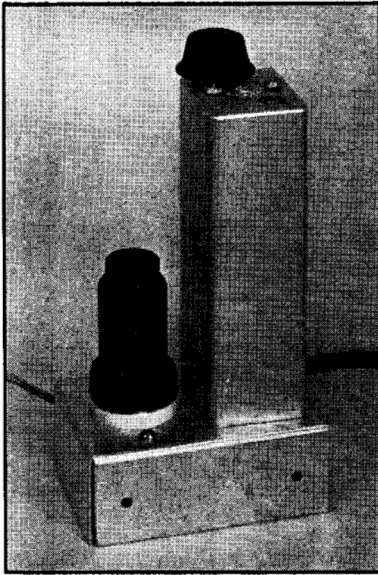

Fig. 825 — Top view of the beat oscillator assembly.

cases. Alternatively, the b.o. frequency may be the same as that of the converter output, which in the case of the converter just described is 1600 kc. A 1600-kc. beat oscillator transformer should be substituted in that event. Should the b.c. receiver be of the tuned radio-frequency type (not a superhet) the latter method is necessary, since the receiver has no intermediate frequency. The 1600-kc. units usually can be adjusted as low as 1500 kc. in case the broadcast receiver's range does not extend beyond the upper-frequency limit of the broadcast band.

Power supply for the beat oscillator may be taken from the broadcast receiver or from the converter power supply. The filament requirements are 0.3 amp. at 6.3 volts, but the plate current drain is negligible.

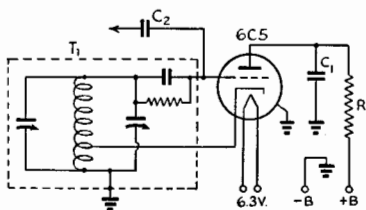

Fig. 826 — Circuit diagram of the beat frequency oscillator.

C_1 — 0.01 μ fd., 400-volt.

C_2 — See text.

R_1 — 50,000 ohms, $\frac{1}{2}$ -watt.

T_1 — 456 beat oscillator transformer, with grid leak and condenser (Millen 63456 or 65456).

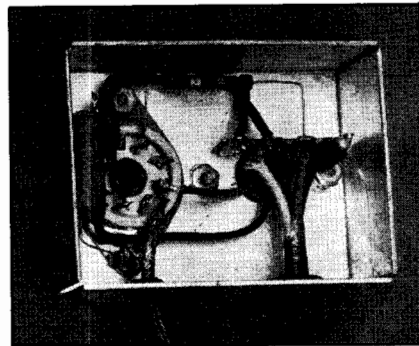

Fig. 827 — Bottom view of the b.f.o. unit.

mounted above chassis on small metal pillars. The ganged tuning condensers are mounted in line in the center of the chassis. They are mechanically connected together, and to the shaft bearing on the front panel, by flexible couplings. The antenna binding posts and the cords for power and r.f. output come through the rear edge of the chassis. It is necessary to cut a rectangular hole in the lower part of the back of the cabinet to make the connections accessible.

The below-chassis view, Fig. 830, shows how the condensers are grouped about the tube socket. The mica condenser, C_5 , is fastened vertically across the socket as close to it as possible (allow room for the tube centering

The Radio Amateur's Handbook

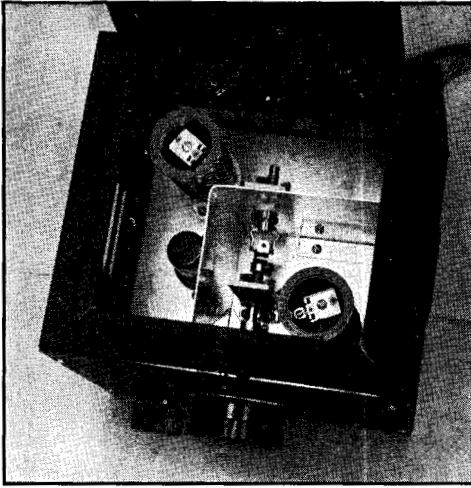

Fig. 828 — Top view of the 14- and 28-Mc. preselector. The padder condensers are mounted inside the coil forms.

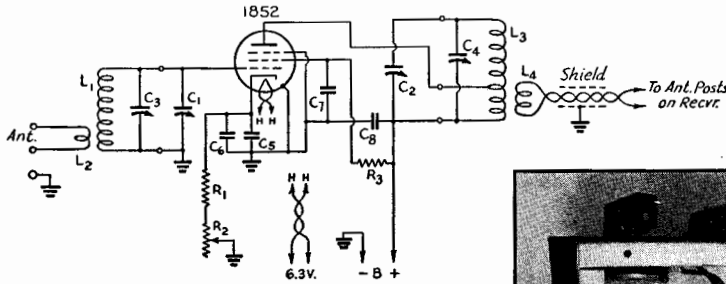

Fig. 829 — Circuit diagram of the preselector.

- C_1, C_2 — 15- μ fd. midjet variable (National UM-15).
- C_3, C_4 — 3-30- μ fd. isolantite-insulated mica padder (National M-30).
- C_5 — 0.002- μ fd. mica.
- C_6, C_7, C_8 — 0.01- μ fd. paper, 400-volt.
- R_1 — 150 ohms, $\frac{1}{2}$ -watt.
- R_2 — 5000-ohm variable.
- R_3 — 60,000 ohms, 1-watt.
- L_1 — 14 Mc.: 9 turns No. 20, diameter $1\frac{1}{2}$ inches, length 1 inch.
28 Mc.: 4 turns No. 20, diameter $1\frac{1}{2}$ inches, length 1 inch.
- L_2 — Close-wound at ground end of L_1 ; 3 turns for 14 Mc., 2 turns for 28 Mc.
- L_3 — Same as L_1 but tapped 3 turns from ground end for 14 Mc. and 1 turn from ground for 28 Mc.
- L_4 — Same as L_2 , on same form as L_3 .

pin to project through the socket) to provide shielding between the grid and plate prongs. The additional cathode by-pass, C_6 , and the screen by-pass, C_7 , also are mounted across the socket on either side of the mica condenser, thus providing additional shielding. With the exception of the ground on C_1 , all r.f. ground connections are made to one lug on the side of the ring holding the tube socket to the chassis (the socket is a National CIR). Shielding about the output leads from L_4 is essential to

prevent unwanted feedback and also to reduce signal pickup on the line going to the receiver. The shield should be continued up to the antenna terminals of the receiver with which the preselector is used. The wires should be connected to the "doublet" terminals on the receiver, and the shield to the receiver ground terminal or chassis. The shield also is grounded to the preselector chassis. This connection between the preselector and receiver chassis is essential for good performance.

Because of the high transconductance of the 1852, very little coupling is needed between input and output circuits to cause self-oscillation when both circuits are tuned to the same frequency. The box containing the unit provides part of the shielding between the two circuits, in addition to that provided by the baffle. This shielding is not complete enough to prevent self-oscillation, however, so the plate of the tube is tapped down on L_3 to reduce the feedback. The tap should be located so that the circuit goes into oscillation with the gain control, R_2 , at about half-scale or less. The controlled regeneration greatly increases the gain and selectivity over that obtainable without regeneration.

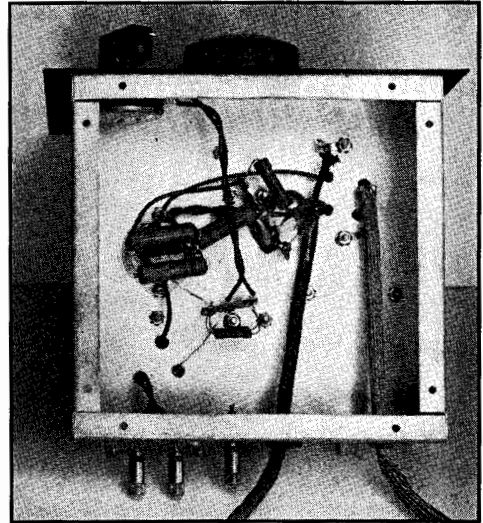

Fig. 830 — Below-chassis view of the preselector. Note grouping of by-pass condensers about the tube socket to provide shielding.

Power for the preselector may be taken from the receiver, since the drain is small. Initial adjustments are simple. With the receiver and preselector turned on, first tune the plate trimmer, C_4 (C_4 and C_3 are mounted inside the coil forms) for maximum noise, with R_2 near

Construction of Receivers

maximum (least resistance). The adjustment will be fairly critical. The tuning condenser should be at about half scale, and the receiver should be set at about the middle of the band. Then set R_2 at minimum gain (resistance all in) and adjust C_3 , the grid padder, for maximum noise. The adjustments may be made on a signal as well as on noise. Next, advance R_2 a little at a time, simultaneously swinging C_3 through resonance, until oscillations commence. Back off R_2 to the point just below oscillation and readjust C_3 and C_4 for maximum output. When the lid of the cabinet is closed the feedback will decrease and R_2 must be advanced more to obtain oscillation. It is not necessary to work near the critical regeneration point under normal conditions so that actual tuning is not critical. The pre-selector must, of course, be kept in tune with the receiver as the latter is tuned over the band.

Should the circuit oscillate at all settings of R_2 , the plate tap should be moved nearer the bottom of L_3 . If no oscillations take place at any setting, move the tap toward the plate end until oscillation starts at about half-scale on R_2 .

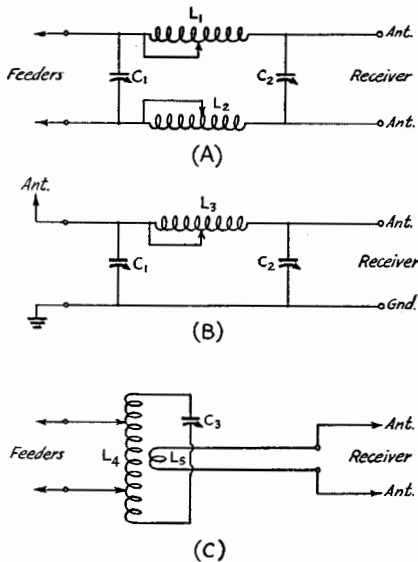

Fig. 831—Three types of circuits for coupling antenna to receiver. *A*, balanced pi-section network; *B*, single-ended pi-section network; *C*, tuned circuit with taps for matching impedances.

C_1 —150- μ fd. variable.

C_2 —100- μ fd. variable.

C_3 —50- μ fd. variable or larger.

L_1, L_2, L_3 —25 turns No. 26, spaced to occupy 1-inch length on 1-inch diameter form; tapped at 2nd, 5th, 9th, and 15th turns.

L_4 —Proportioned to resonate with C_3 in the desired band.

L_5 —3 or 4 turns wound on L_4 ; see text.

The improvement in gain and reduction of image response will depend upon the amount of regeneration used. With average-strength signals and regeneration below the critical point for easy tuning, the signal-to-image ratio will be improved by a factor of 40 to 50 on 28 Mc., and 100 or more on 14 Mc. Used with the average receiver having one r.f. stage ahead of the mixer, this means that the overall image ratio will be of the order of 5000 on 14 Mc. and 400 or 500 on 28 Mc. The voltage gain is about 100 under the same conditions. Greater selectivity and gain can be obtained by working closer to the critical regeneration point.

● ANTENNA TUNING UNITS

Obviously the signal-to-noise ratio will be improved by a means which makes the signal strength at the receiver input as large as possible. A separate antenna tuning unit, designed to couple between antenna and receiver, therefore is a desirable addition to the receiving equipment. It is especially useful when the transmitting antenna is used for receiving.

Typical couplers of this type are shown diagrammatically in Fig. 831. At *A* is the balanced pi-section matching network, applicable to antenna systems using two-wire feeders. Specifications suitable for average conditions are given. The taps on L_1 and L_2 are varied simultaneously so that the same inductance is in use in each branch, with trial settings of C_1 and C_2 until the signal strength on the desired frequency is maximum. With the average antenna system the settings are not critical, although slight readjustment may be necessary when going from one end to the other of a wide band.

The single-ended pi-section filter is shown at *B*. This filter is intended for use with a single-wire antenna or other system worked against ground.

A parallel-resonant circuit with provision for impedance matching is shown at *C*. The coil L_4 should be constructed so that the turns readily may be tapped. The pickup coil, L_5 , may consist of three or four turns wound around the center of L_4 , for the usual receiver having approximately 500-ohm input impedance. The feeder taps on L_4 should be adjusted for maximum signal strength when C_3 is tuned to resonance. In case a single-wire antenna is used, L_5 should be coupled to the bottom of L_4 , which in turn is connected to ground. The antenna is tapped on L_4 at the point giving maximum signal as before.

Bibliography

¹ "How to Become a Radio Amateur," 8th Edition.

² Grammer, "Modernizing the Regenerative Super-het," *QST*, November, 1940.

³ Chambers, "A One-Tube Five-Band Converter," *QST*, October, 1940.

Tuning and Adjusting Receivers

Getting the Most out of Receivers — Alignment — Tuning with Crystal Filters

THERE are four types of receivers used at the present time: the regenerative, the straight superheterodyne, the single-signal superheterodyne and the superregenerative. A thorough understanding of the principles involved and the "feel" of each type is an indispensable asset to any amateur. Unless the operator can tell by handling a receiver whether or not it is working properly, he can struggle along with a receiver incapable of its best performance solely because of the lack of skill and experience of the operator. Simply because a receiver bears a well-known trademark is no assurance that it is always working at its best. Troubles attributed to old tubes in a receiver are often caused by misalignment of stages or other causes, and a new set of tubes will not correct the condition.

● TEST EQUIPMENT

Contrary to popular opinion, it is not necessary to own a complete laboratory to work on a receiver. A commercial set that is only slightly out of line requires nothing more than an insulated screw-driver or wrench to bring it back into first-class condition, and the situa-

tions are rare where more than a 1000-ohms-per-volt voltmeter will be required to check a receiver, although an ohmmeter is a handy addition to the meter. A test oscillator, particularly if it is calibrated, is a useful adjunct to the station, but the station's frequency standard will often serve instead.

Measuring voltages is a simple matter if a high-resistance (1000-ohms-per-volt) voltmeter is available. A lower resistance meter can be used, but it will read low in high-resistance circuits. The most convenient ranges are 0-30, for reading cathode-bias voltages, and 0-300, for reading plate voltages. Cathode (grid-bias) voltages are read between cathode and ground — the ground is negative and the cathode is positive — and plate and screen voltages are read between cathode (or ground, if the bias voltage is low) and the plate or screen. See Fig. 901. One should familiarize himself with the tube socket connections of the various tubes so that the elements can be readily identified.

● REGENERATIVE RECEIVERS

The principle of the regenerative receiver has been explained in Chapter Four and will not be repeated here. However, the method of tuning a regenerative receiver depends on whether it is being used for 'phone or c.w. reception. The regenerative receiver is not recommended for 'phone reception in crowded bands because of the lack of selectivity (particularly on the higher frequencies) and the tendency to lose what selectivity it may have on strong signals. Nevertheless, the tuning procedure differs slightly and, since it does come in handy occasionally, will be explained.

There are two main controls on a regenerative receiver, the tuning control and the regeneration control. As their names imply, they control the tuning or frequency and the amount of regeneration. In most cases, the regeneration control has to be changed slightly as the tuning control is changed, making the receiver essentially a two-control affair requiring both hands for adjustment.

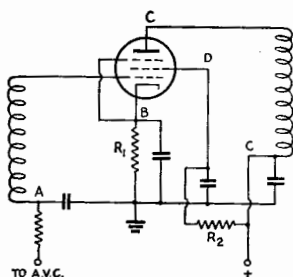

Fig. 901 — Voltage measurements on a typical stage of r.f. or i.f. amplification. The negative terminal of the voltmeter is connected to the chassis (ground) and the positive terminal placed at B will give the grid bias due to the cathode resistor, touched at C will show the plate voltage (minus the grid voltage) and at D will show the screen voltage (minus the grid voltage). A high-resistance voltmeter between A (minus) and ground will give an indication of the voltage developed by the a.v.c. but will read low.

Tuning and Adjusting Receivers

C.W.

For c.w. reception, the regeneration control is advanced until the receiver breaks into a "hiss," which indicates that the detector is oscillating. In some instances the receiver will break into this hiss with a "plop," which is an undesirable condition and should be remedied as explained later. Further advancing of the regeneration control after the detector starts oscillating will result in a slight decrease in the strength of the hiss and, in some instances when the control is advanced far enough, into a high-pitched whistle and increased hiss which indicates that the detector is "superregenerating" or "squegging." The use of this condition is explained in Chapter Twenty-nine — it is not used in c.w. reception. Sometimes the receiver will break into a squeal (unaffected by tuning) almost immediately after the hiss point is reached — this indicates "fringe howl" and should not be tolerated. It can be corrected as explained later. The properly-operating regenerative detector will, when the regeneration control is advanced, smoothly break into the hiss condition (caused by the "beating" of the oscillating detector with the external and internal noise) and, when the regeneration control is backed off, smoothly break out of the hiss condition. The going in and out of oscillation (the hiss point) should occur at the same point on the regeneration control and any great discrepancy should not be tolerated.

The proper adjustment for the reception of c.w. signals is just after the detector has started to hiss, when it will be found that c.w. signals can be tuned in and will give a tone with each signal depending on the setting of the tuning control. As the tuning control is varied and one tunes into a signal, it will start out at a very high pitch, go down through "zero beat" and disappear at a high pitch

on the other side, as shown in Fig. 902. It will be found that a low beat-note cannot be obtained with a strong signal because the receiver "pulls in" or "blocks," but this condition can be corrected by advancing the regeneration control until the beat-note occurs again. If the regenerative detector has an r.f. amplifier stage ahead of it, the blocking can be eliminated by backing-off the gain control of the r.f. stage, but with no r.f. stage the blocking condition can only be eliminated by advancing the regeneration control or loosening the antenna coupling (in receivers where the coupling is variable).

Because a signal is obtained on either side of zero beat, two signals near the same frequency can be separated sometimes by trying to tune in the undesired signal at zero beat or by listening to the desired signal on first one side of zero beat and then the other and using the side that gives the least response from the interfering signal. There is no substitute for experience in the handling of a regenerative receiver, and the operator will find that continued practice will enable him to separate signals on the regenerative receiver that at first seemed hopelessly jammed.

The point just after the receiver starts oscillating is the most sensitive condition of the receiver and should be used for listening to weak c.w. signals — further advancing of the regeneration control makes the receiver less prone to blocking by strong signals but less capable of receiving weak signals.

'Phone

If the receiver is in the oscillating condition and a 'phone signal is tuned in, a steady whistle will result (the beat of the detector with the 'phone carrier) and, while it is possible to listen to 'phone if the receiver can be tuned to exact zero beat, it is more satisfactory to back off the regeneration control to the point where the whistle stops, at which time the voice or modulation will instantly clear up and can be listened to without any trouble. The most sensitive and selective condition for 'phone reception is just before the receiver goes into oscillation. However, a strong 'phone signal will tend to reduce the selectivity of the receiver and it is very nearly impossible to listen to a weak 'phone signal near (in frequency) a strong one.

The best way to listen for 'phone signals with a regenerative receiver is to put the receiver in the weakly oscillating condition (at the point where the hiss starts) and first locate the carrier by the whistle or beat. The regeneration control is then backed off until the whistle disappears.

R.F. Stage

If the regenerative detector is preceded by an r.f. amplifier, the amplifier should always be tuned to the same frequency as the signal.

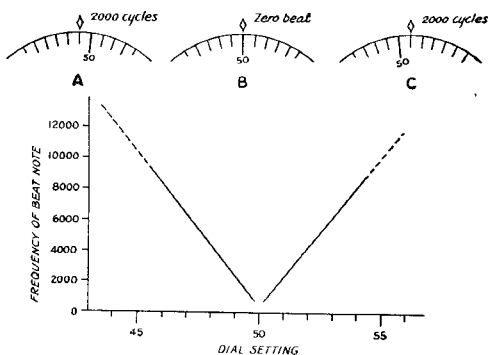

Fig. 902 — As the tuning dial of a receiver is turned past a c.w. signal, the beat note varies from a high one down through "zero beat" and back up to a high one, as shown at A, B and C. The curve is a graphical representation of the action. The beat exists past 8000 or 10,000 cycles but usually is not heard because of the limitations of the audio system of the receiver.

The Radio Amateur's Handbook

This condition can be checked by tuning the condenser or trimmer (if the controls are ganged) for maximum signal or, if no signal is available, by the setting that requires the *minimum* setting of the regeneration control for oscillation. The gain control of the r.f. stage is used to reduce the signal at the detector — detuning the r.f. stage to reduce the gain should only be necessary when the signal is exceedingly strong.

For c.w. work, an r.f. stage will only serve as a useful gain control and as a buffer between a swinging antenna and the oscillating detector, and it adds very little to the useful sensitivity. However, it will contribute materially to the sensitivity of a regenerative receiver used for 'phone reception and is recommended in this application.

Smooth Regeneration

Three things can influence the smoothness with which the regenerative detector goes into oscillation: the amount of feedback (setting of cathode tap or number of tickler turns), the coupling to the antenna or previous stage, and the size of the grid leak. The feedback should be adjusted so that the detector breaks into oscillation at the recommended screen-grid voltage (see Chapter Eight). If it only oscillates at a higher voltage, too little feedback is present and the cathode tap should be moved higher on the coil or turns added to the plate coil, and if it oscillates at too low a plate voltage, turns should be removed from the plate coil, the cathode tap moved down, or the antenna coupling tightened. The highest value of grid leak that will permit smooth regeneration should be used — if this value falls below one megohm the other sources of trouble should be checked, since a value of less than one megohm will detract from the sensitivity. If an r.f. stage is used, the one megohm value will be satisfactory, but a value of two to five megohms will be preferable if no r.f. stage is included in the receiver. Low values of grid leak make the detector less sensitive but capable of handling larger signals without overloading.

Antenna Coupling

The tighter the antenna coupling is made, the greater will be the feedback required or the higher will be the voltage necessary to make the detector oscillate. The antenna coupling should be the maximum that will still allow the detector to go into oscillation smoothly, without a "plop," and with the correct voltages on the tube. If capacity coupling to the grid end of the coil is used, only a very small amount of capacity will be needed to couple to the antenna. Increasing the capacity increases the coupling.

Hum

It may be found that the regenerative detector will hum badly at the point of oscillation, the hum being caused by pick-up of the alternating house-lighting current. The hum can be eliminated by better shielding of the grid of the detector tube and the lead running to it, and sometimes by grounding the chassis of the receiver to a good physical ground connection. The power supply must, of course, be capable of delivering ripple-free current, and if the heaters of the tubes are supplied with a.c., one side of the heaters should be grounded to the chassis and the other side by-passed to ground through a 0.01- μ fd. condenser; or both sides can be by-passed to ground and the center-tap of the heater winding connected to ground.

Body Capacity

Occasionally it will be found that a regenerative receiver shows a tendency to change frequency slightly as the hand is moved near the dial. This condition ("body capacity") can be caused by poor design of the receiver or by the type of antenna that is being used. If the body capacity is still present when the antenna is disconnected, it can be eliminated by better shielding, and sometimes by r.f. filtering of the 'phone leads. If, however, the body capacity effect is still present when the antenna is again connected, it is probably caused by the antenna system. A good, short ground connection should be connected to the receiver and the length of the antenna varied (by adding a small coil or variable condenser in the antenna lead) until the effect is minimized. Connecting the antenna to a point down on the coil (such as the cathode tap) will sometimes eliminate the unwanted effect of body capacity.

Trouble Shooting

In any discussion of trouble shooting, it must be assumed that the receiver has been wired correctly in the first place. This can be checked by a careful comparison with the wiring diagram and by means of a voltmeter to see that all the tube-element voltages-to-ground are approximately what they should be. A continuity-checker, which can be simply a high-range ohmmeter, can be used to check through a receiver to make certain that all components are connected together that should be and that the circuits have the correct resistance in them as indicated by the wiring diagram. The continuity check should not be made with heater or plate voltages on the set.

If the wiring is checked satisfactorily and the detector cannot be made to oscillate, it indicates that not enough feedback is present. If a cathode-tap type of circuit is used, the tap

Tuning and Adjusting Receivers

should be moved up towards the grid end of the coil a turn at a time until oscillation takes place. If a plate coil is used, turns can be added or the plate coil can be moved closer to the grid coil. The proper polarity of the plate coil is necessary and, if both coils are wound in the same direction on a form, the grid connection should be the top end of the grid coil and the plate connection should be the lower end of the plate coil. See Fig. 903.

If the receiver "plops" going in and out of oscillation, the feedback, antenna coupling

amount of selectivity contained in the, i.f. amplifier. Single-signal reception is normally only applied to c.w. reception, although it is possible in some cases to improve 'phone reception by a receiver with high selectivity in i.f. amplifier.

As explained in Chapter Four, the high selectivity necessary for single-signal reception is obtained by either a regenerative i.f. amplifier or an amplifier incorporating a crystal filter. Cutting out the regeneration or crystal filter changes a single-signal superheterodyne to a straight receiver — the rest of the receiver is the same in both cases.

The superheterodyne has two or more tuned circuits that must be adjusted for each signal, but these circuits are usually ganged in most modern receivers and thus the superheterodyne can be considered a single-control receiver. Some homemade superheterodynes separate the high-frequency-oscillator control and the signal-circuit control, to eliminate tracking difficulties, and this makes the receiver a two-control affair. However, the signal-circuit tuning is not too critical, unless regeneration is used, and presents no real handicap. The signal circuit is always peaked (tuned for maximum response) after the signal has been tuned in — if the band is dead the signal circuit is kept in track with the high-frequency oscillator by peaking it on the noise.

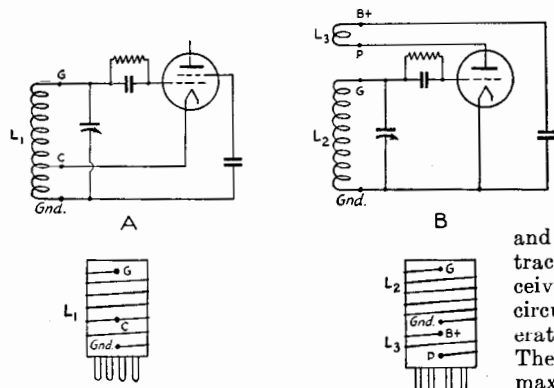

Fig. 903 — The two common types of oscillator circuits used in receivers and the corresponding way in which the coils must be wound to insure proper feedback for oscillation.

and grid leak must be juggled about until smooth results are obtained. There is no one adjustment that can be made to clear up this condition. *Fringe howl* indicates r.f. getting into the audio-amplifier tube, and better filtering and by-passing of the output of the detector will usually eliminate fringe howl. If a choke or transformer is used in the plate circuit of the detector for coupling to the audio tube, a resistor should be shunted across the choke or the secondary of the transformer to reduce fringe howl. The value of the resistor should be the maximum required to reduce the howl and will normally be between 50,000 and 250,000 ohms.

If the oscillating detector seems to *creep* badly in frequency, or if it is too *sensitive to voltage fluctuations* caused by a slight change in line voltage, it indicates that the detector tube is a bad one, that there is not enough capacity in the tuned circuit, or that the plate voltage is too high. A high L/C ratio in the tuned circuit will give maximum sensitivity and a low L/C ratio will give maximum stability — a compromise should be reached in each case.

● THE SUPERHETERODYNE

The straight superheterodyne differs from the single-signal superheterodyne in the

'Phone

For 'phone reception, the b.f.o. (beat-frequency oscillator) is turned off, the a.v.c. (automatic volume control) is turned on, and the tuning control, or controls, adjusted for the desired signal. The r.f. gain control is normally turned up to maximum and the audio-volume control adjusted for a comfortable level. The a.v.c. takes care of changes in signal due to fading and also different signals of varying strengths, within the limit of its control.

Occasionally, when listening to very weak signals, it will be found that better intelligibility can be obtained with the a.v.c. off, but with signals of any appreciable strength the a.v.c. will be an invaluable asset in preventing overloading and sudden changes in volume.

When two or more 'phone carriers are close together (in frequency) they will beat with each other and make it difficult to copy either signal. If a crystal filter is available in the receiver, it can be used to eliminate this "heterodyne" by turning it on and adjusting the "phasing" control until the undesired signal is eliminated or attenuated as much as possible. A slight adjustment of the tuning control may be necessary at the same time. Because of the increased selectivity introduced by the crystal filter, the fidelity of the signal will not

The Radio Amateur's Handbook

be as good as with the filter out, but it will allow signals to be copied through interference that would otherwise render them unreadable. A few hours' practice will make the operator familiar with the use of the crystal filter for eliminating heterodynes.

The crystal filter will also help in the reception of weak signals by reducing the noise passed by the i.f. amplifier and thus increasing the signal/noise ratio of the receiver. However, it can only be used with signals of excellent stability that show no frequency modulation.

C.W.

For c.w. reception with no crystal filter, the a.v.c. should be set in the "off" position and the b.f.o. should be turned on. It will be noted that as the frequency of the b.f.o. is varied, the pitch of the noise in the receiver will change. The b.f.o. should not be set so that the pitch of this noise is the lowest possible but slightly to one side of this adjustment. Another way that the b.f.o. can be adjusted properly is to turn it off and tune in a c.w. signal for maximum strength. No beat note will be obtained but it will be easy to tell (by the hissing noise) when the signal has been peaked. The b.f.o. is then turned on and its frequency adjusted for the desired pitch of the signal. Most operators like to listen to a note of from 600 to 1200 cycles — the most pleasing pitch is the one to use.

After the b.f.o. has been set, c.w. signals can be tuned in and no further adjustments will be necessary, except the proper control of volume. Since c.w. receivers do not use a.v.c., it is necessary to control the r.f. volume manually. For weak-signal reception, the r.f. gain control should be set at maximum and the audio gain control set at a value that just enables the operator to hear the background noise. If too much volume is used, the rush of the background noise will tend to paralyze the ears and will prevent the reception of weak signals. Strong signals will sound better if the r.f. gain is backed off enough to prevent any tendency towards overloading throughout the set.

Interference can be dodged in much the same way as with a regenerative receiver, by trying to find an adjustment that minimizes the interfering signal or puts it at zero beat. It is easier to do with a superheterodyne because the super has much less tendency to block on strong signals. However, the ear provides plenty of selectivity, and the good operator will, through experience, be able to separate two signals that are quite close together simply by concentrating on the desired one.

Single-Signal Reception

If a crystal filter is incorporated in the receiver, much more satisfactory c.w. reception

can be obtained than is possible with a less selective super. Unfortunately, too many amateurs let the crystal filters in their receivers go to waste because they have never taken the trouble to familiarize themselves with the operation. Some also have the idea that the crystal filter reduces the sensitivity of the receiver, but the opposite is true. The properly-adjusted crystal filter makes a superheterodyne many times more sensitive than it could be without the filter. When the filter

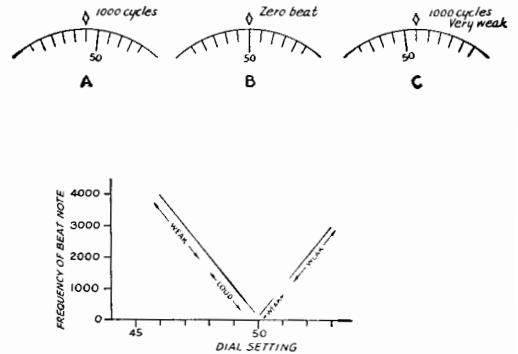

Fig. 904 — A graphical illustration of how the single-signal receiver tunes. As the tuning dial is turned into the signal, the signal gets louder, as represented by the heavier portion of the line in the graph. As it goes down through zero beat and up on the other side it is very weak, and is inaudible at one point, as shown by the discontinuity in the thin line. The point of inaudibility is the point corresponding to the "rejection slot" of the crystal.

is cut into the receiver, a reduction in the noise will be noticed, and this has led many to believe that the gain has been reduced. The gain has not been reduced, but the band-width has. Since the c.w. signal consists of energy on but one frequency, a wide band-width is not necessary. On the other hand, the noise power is proportional to the band-width, so if the filter cuts the band-width down to one-tenth its former value, the noise has been cut to one-tenth but the signal remains the same, resulting in a ten-times increase in available signal/noise power ratio.

The crystal should not be switched in only when interference conditions become too severe, but it should be left in the circuit for all c.w. reception. This is an important point — the selectivity of the crystal makes it easy to lose the signal at the instant the crystal is switched in. Operate with the crystal in at all times.

The adjustment of the crystal filter is simplicity itself. With the b.f.o. and a.v.c. off and the crystal switched in, the "band-width" or "selectivity" control of the filter is turned

Tuning and Adjusting Receivers

to the setting normally used for c.w. reception. In the case of receivers with "full-range selectivity" this will be one or two points back from the sharpest setting or, with the older-type filters, the point of maximum "hiss" noise. A signal is then tuned in and peaked, and then the b.f.o. is turned on and adjusted for the desired pitch of signal. The tuning control of the receiver is then moved slightly until the signal has passed through zero beat and is tuned in at about the same pitch on the other side of zero beat. Now, adjusting the "phasing" control will give a setting where the signal is practically eliminated. The filter is now adjusted for single-signal reception. It will be found that most signals are received on only one side of zero beat and that only the very strongest signals can be heard on the other side. By thus eliminating one side of zero beat, the amateur band being tuned is effectively doubled in width. Even the strongest interfering signals can be eliminated by minor adjustments of selectivity control, to sharpen up the selectivity, along with close adjustments of the phasing control, to reject the unwanted signal. A 450-kc. crystal filter will normally be used in its broadest position for c.w. work, while the 1600-kc. crystal filter, which is not capable of as much selectivity, will normally be used at its sharpest setting. In any case, the adjustment of the selectivity control which gives the least noise is the sharpest position, but this can be too sharp with a 450-kc. crystal and is not normally used.

Some commercial receivers have no bandwidth selectivity control brought out to the panel, in which case only the phasing control can be used. However, the operation is the same as mentioned above, except that only variable rejection adjustments are allowed.

If a *regenerative i.f. amplifier* is used to obtain single-signal reception, the amplifier regeneration control is advanced until the amplifier breaks into oscillation and is then backed off just to the point where the amplifier is just out of oscillation. This is the most selective condition for the amplifier, and it is now only necessary to adjust the b.f.o. for the proper pitch of the hiss to have single-signal reception. There is no phasing or "rejection" control on a regenerative i.f. amplifier, but considerable selectivity can be obtained and a very marked reduction of the signal on the other side of zero beat will be noticed. Strong signals will tend to "flatten out" the selectivity of the regenerative i.f. amplifier, and strong signals should be cut down by backing off the gain ahead of the i.f. amplifier, if this is possible, to retain the selectivity.

Time spent in familiarizing one's self with the proper handling and adjustment of a single-signal superheterodyne is an excellent invest-

ment that will pay dividends under severe interference conditions. Until one is thoroughly familiar with the adjustment of the crystal filter, it is most convenient first to adjust it by listening to a commercial transmitter sending continuously outside one of the amateur bands, or a signal from the frequency meter can be used. The important thing to remember in single-signal reception is that the b.f.o. is set so that the signal is louder on one side of zero beat than on the other and, with the crystal filter, the phasing control is set to give rejection on the weak side of zero beat.

Regenerative Preselectors

Regenerative preselectors are often used to improve the image ratio of a superheterodyne which does not, in itself, have sufficient selectivity ahead of the mixer to reject images. They are most useful on the 14- and 28-Mc. bands. They have maximum gain at the point just before they go into oscillation, and this is also the point of maximum selectivity. However, they tend to lose selectivity on strong signals and, for this reason, it is best to operate them with the regeneration backed off slightly if a strong signal is near the one being received. Because of its selectivity, it is difficult to keep a regenerative presselector tuning in line with the other signal circuits in the front end of a superheterodyne, and it is usually provided with a separate tuning control. This control becomes more critical as the regeneration is increased, and it is good practice to back off the regeneration control until a signal is tuned in on the receiver, and then the regeneration can be advanced and the signal peaked with the presselector.

Alignment of I.F. Amplifiers

Some sort of signal generator is invaluable in aligning i.f. amplifiers, although it is possible to align them by the noise alone. Assuming that a signal generator is available, a signal lead from the generator is clipped on to the grid lead of the last i.f. amplifier tube and the trimmers of the transformer feeding into the second detector are adjusted for maximum signal in the output. The frequency of the signal generator is set to the nominal frequency of the i.f. amplifier. The lead from the generator is then clipped on to the grid lead of the next to the last i.f. amplifier tube and the next i.f. transformer is aligned by adjusting the trimmers. The process is continued, working back from the second detector, until all of the i.f. transformers have been tuned. It will be necessary to decrease the signal from the generator as more and more of the i.f. amplifier is used because of the increased gain as more stages are brought into alignment. The i.f.

The Radio Amateur's Handbook

transformer in the plate circuit of the mixer is adjusted with the i.f. signal introduced to the grid of the mixer.

If a tuning meter that works from the a.v.c. system is incorporated in the receiver, it can be used as a check on the alignment, and the a.v.c. of the receiver should be left on when the i.f. is being aligned. However, if no tuning meter of this type is used, the a.v.c. should be turned off during alignment, and the ear or an output meter can be used to show maximum response.

If the i.f. amplifier uses a crystal filter for single-signal reception, the signal generator must be set for the nominal frequency of the crystal and the amplifier aligned as described above. However, it is probable that the alignment will not be exact for the crystal frequency (which probably differs by a few k.c. from the one on which the amplifier was tuned) and so the signal generator frequency should be varied slightly back and forth, with the crystal in the circuit, until the peak of the crystal resonance is noticed, and the amplifier can then be realigned on this frequency. If desired, the crystal frequency can be obtained at first by placing the filter crystal in an oscillator built for the purpose and using the output to align the i.f. amplifier. After the crystal has been put back in the i.f. amplifier, the trimmers should be touched up again, since the oscillating frequency and the response frequency of the crystal may differ slightly.

Part of the success of a single-signal superheterodyne is dependent upon the i.f. amplifier being aligned with the crystal frequency — it is well to check this from time to time to assure peak performance.

Adjustment of B.F.O.

The b.f.o. trimmer is set so that the frequency of the b.f.o. can be adjusted, by means of the panel control, to a frequency either side of the intermediate frequency and thus give a suitable beat note. It can be adjusted by turning the gain of the i.f. amplifier wide open and turning the trimmer of the b.f.o. until the hissing noise of the b.f.o. beating with the random noise is heard or, if the signal generator is left on, until a beat is obtained with the signal from the generator.

Alignment of Front End

Since the high-frequency oscillator must always tune to a slightly different frequency than the signal circuits in a superheterodyne — the difference is equal to the intermediate frequency — the two circuits must "track" if single control is to be used. This is not as difficult a problem as it may first appear, since home-made receivers are usually built to cover only the amateur bands, and it is a

relatively simple matter to make circuits track over a small range. In commercial receivers, the job has already been done by engineers, and it is only necessary to compensate from time to time for the minor changes due to humidity and temperature changes and the variations in tubes.

Assuming that the front end of the receiver works but does not track exactly, the first step is to adjust the frequency range of the high-frequency oscillator. The tuning dial is set to the high-frequency end of the band and the trimmer is adjusted until the frequency of the oscillator is right to give a signal at the high-frequency end. The tuning dial is then turned to the point where the low-frequency end should tune — if it tunes to too low a frequency it shows that too much inductance is present; if it tunes to too high a frequency more inductance is required. Slight adjustments of inductance can be made by spacing turns.

Once the range of the oscillator has been adjusted, the signal circuits are aligned at the high-frequency end of the range and then checked at the low-frequency end of the dial. If capacity must be added at the low-frequency end to bring the circuit into resonance, it indicates that more inductance is needed — if less capacity is needed, it shows that too much inductance is present.

In a commercial receiver, resetting the trimmer condensers at the high-frequency end of the scale will normally be all that is necessary.

A commercial receiver of the type using a band-set dial and a band-spread dial can be brought to peak efficiency by aligning it in the amateur bands rather than at the high-frequency ends of the tuning ranges, since it is possible for a receiver tracking over such a large frequency range to go out of line at some of the intermediate points, and one of these points might be the amateur band that interests the operator.

Alignment of Lamb Noise Silencer

The adjustment of the Lamb type of noise silencer depends on the proper alignment of the separate i.f. channel used as the noise amplifier and rectifier. It is aligned after the regular i.f. amplifier has been adjusted. A steady carrier is tuned in and the noise control on the panel is advanced. The trimmers on the transformers of the noise amplifier are then adjusted until the receiver blocks up. Backing off the noise control will bring the carrier back and the trimmers can be adjusted still further. The correct adjustment of the trimmers is that which gives the blocking effect with the minimum advance of the noise control. This setting should occur with the noise control about three-quarters advanced.

Tuning and Adjusting Receivers

The receiver is normally operated with the noise control in the "off" position. When some noise is heard, the control is advanced to the point where the noise dies out, leaving the operator free to tune across the band as usual. The noise control must be backed off slightly on strong signals, to prevent blocking of the receiver.

If separated-pulse type noise is not properly reduced by the silencer it normally indicates regeneration or perhaps too much lag in the lead back to the injection grid of the silencing tube, and the condensers and wiring should be checked for excessive capacity.

Trouble Shooting in Superheterodynes

Misalignment of i.f. amplifier can be detected by broadened tuning and lack of sensitivity. It can be corrected by realignment.

I.f. amplifier off tune with crystal will show up by peaking a carrier (b.f.o. off) with the crystal out of the circuit and noting the tuning dial setting. The crystal is then switched in and the carrier peaked again. If the two tuning dial settings are different it indicates that the i.f. amplifier is not tuned to the crystal frequency. Occasionally it will be found possible to tune in a station sharply at two points 10 kc. or so apart on the dial (with the crystal in) but only one of these points will give a beat with the b.f.o. This is caused by a poorly-aligned i.f. amplifier allowing a secondary response peak of the crystal to show up. Such a secondary peak may result from a chipped or otherwise damaged crystal.

Front end out of track is indicated by a variation in the noise response of the receiver as it is tuned from one end of the tuning range to the other, with the antenna removed. A quick spin of the dial will show that the noise comes up at several settings and drops off at others. If the effect is pronounced, it is well to make certain that one of the dead spots does not coincide with one of the amateur bands. If it does, the front end should be made to track on the amateur band. The noise will be less on the higher-frequency bands.

Front end signal circuits out of line can be detected by disconnecting the antenna. The noise in the headphones or speaker should decrease. The grid of the first r.f. stage should then be shorted to ground with a 0.01- μ fd. condenser and the noise should decrease still further. Working through the signal circuits of the receiver (r.f. stages and mixer), as each grid is shorted by the condenser the noise should decrease. The effect will be most noticeable on the lower frequencies but should be apparent even at 14 Mc. and will show up on an excellent receiver at 28 and 56 Mc.

The above troubles apply to both commercial and home-made receivers alike — the

following troubles occur when a new home-made receiver is first put into operation:

Oscillating i.f. and r.f. amplifiers show up when the b.f.o. is turned on and the r.f. (and i.f.) gain control is advanced to the full position. A loud howl will result or the set will block up. The stage responsible for the oscillation can be found by starting from the input of the set and shorting the grid of each tube to ground by a 0.01- μ fd. condenser. When a tube is reached that stops the effect, the immediate circuits should be studied in an effort to locate the cause. Oscillation in an amplifier is normally caused by high-impedance cathode or screen-grid returns or by inductive coupling between grid and plate circuits. The former causes can be checked by by-passing the cathode or grid right at the socket — the latter can usually only be rectified by additional shielding or changing the orientation of the coils. Sometimes the oscillation can be caused by long ground returns — it is well to ground all leads for any one stage close to the socket of the tube and not to depend upon the chassis to any great extent.

Instability with 'phone reception can be caused by an unstable high-frequency oscillator, and with c.w. reception (evidenced also by modulation of all signals) it can be caused by either an unstable high-frequency oscillator or an unstable b.f.o. The b.f.o. can be checked by feeding a signal in at the intermediate frequency — if the instability is still present it is caused by the b.f.o. H.f. oscillator instability can be caused by a loose connection, poor tube, poor resistor in the grid or plate circuit, poor voltage regulation or, in sets where a pentagrid converter is used, by overloading of the mixer. All of these factors should be checked in looking for the trouble.

Oscillator coupling is an important factor in the home-made receiver and should never be left to chance. If the oscillator is capacity-coupled to the mixer, reducing the value of the coupling condenser will reduce the coupling. If inductive coupling is used, fewer turns in the coupling coil or moving it farther away will reduce the coupling. If too little coupling is used, the receiver will lack sensitivity, and if too much is used (except in the case of the 6L7 mixer) the receiver will be easy to overload and selectivity will be reduced. The optimum coupling can usually be found by reducing it to the point where the gain begins to drop off. The performance of a 6L7 is more or less independent of oscillator voltage, and no adjustment is necessary.

Too much b.f.o. voltage is sometimes a disadvantage during weak-signal reception. It can be cut down by reducing the coupling or reducing the d.c. voltage on the b.f.o. Too little b.f.o. voltage will be apparent by a tend-

The Radio Amateur's Handbook

ency for strong signals to "block" and "mush" without giving a solid beat note. However, reducing the r.f. gain and increasing the audio gain will give a good signal in this case.

Antenna coupling plays a large part in determining the *image ratio*. With an i.f. of 450 kc. and one stage of r.f. ahead of the mixer, no trouble with images should be experienced on 7 Mc. and below. Some may show up on 14 Mc. (especially from 15-Mc. band broadcasting) and they are to be expected on 28 Mc. and higher. Two stages of r.f. should give little or no image interference on 14 Mc. If only a few images are noticed, they can be reduced by loosening the antenna coupling, but the antenna coupling should never be loosened beyond the point where signals start to drop off noticeably. If images occur on 7 Mc. and lower with one stage of r.f., it is an indication that the antenna is too closely coupled, or possibly the r.f. stage is too closely coupled to the mixer.

If a regenerative preselector is used, the antenna coupling should be adjusted so that the preselector will oscillate with the regeneration control set at about three-quarters in. If it refuses to oscillate, the antenna coupling is too tight or not enough feedback is present. If the preselector cannot be made to oscillate, it will be impossible to reach the point of maximum gain and selectivity except in rare instances.

In general, receivers should first be aligned and adjusted by working from the output up towards the input. In shooting trouble, however, it is sometimes more convenient to work from the input towards the output, as in the case of running down an oscillation or finding a stage that lacks gain. Tubes should be shorted at the grid or plate by a condenser so as to short the r.f. but not to disturb the d.c. voltages.

● SERVICING SUPERHETERODYNES

In addition to the general receiver servicing suggestions already given, there are a few others for troubles peculiar to superhet type receivers. Generally poor performance, characterized by broad tuning and poor sensitivity, calls for checking of the circuit tuning and alignment as previously described. The procedure is to start with the receiver output (audio) and work back as mentioned previously.

In case of oscillation in high-frequency amplifier and first detector circuits, as evidenced by squeals or "birdies" with varying of their tuning, look for poor connections in the common ground circuits, especially to the tuning condenser rotors. Inadequate or defective by-pass condensers in cathode, plate and screen-grid circuits also can cause such oscillation. In

some cases it may be advisable to provide a baffle shield between the stators of pre-r.f. amplifier and first-detector ganged tuning condensers, in addition to the usual tube and inter-stage shielding. A metal tube with an ungrounded shell will cause this trouble. Improper screen-grid voltage, as might result with a shorted or too-low screen-grid series resistor, also could be responsible.

Oscillation in the i.f. circuits, independent of high-frequency tuning and indicated by a continuous squeal when the gain is advanced with the c.w. beat oscillator on, will result from similar defects in i.f. amplifier circuits. Inadequate cathode resistor by-pass capacitance is a very common cause of such oscillation. Additional by-pass capacitance, 0.1 to 0.25 μ f., usually will remedy it. The same applies to screen-grid by-passes of i.f. tubes.

"Birdies" and "mush" occurring with tuning of the high-frequency oscillator may indicate that it is "squegging" or oscillating simultaneously at high and low frequencies. This may be caused by a defective tube, too-high oscillator plate or screen-grid voltage, excessive feed back in the oscillator circuit or excessive grid-leak resistance.

Excessive "hiss" may be caused by a defective h.f. or i.f. tube, by an open grid circuit, or by misalignment of high-frequency or i.f. circuits. It may be helpful in some cases to reduce the oscillator screen voltage, in the case of an electron-coupled oscillator, or the plate voltage in the case of a triode. The same symptoms and remedies apply to the c.w. beat oscillator and its coupling to the second detector. There should be some increase in hiss when the latter is switched on, as a result of the i.f. noise components beating with the carrier it furnishes in the second detector.

High-frequency harmonics from the c.w. beat oscillator will show up as steady "carriers" which tune in like signals. These can be identified by disconnecting the antenna. If they remain the same with antenna on or off, they are almost certainly traceable to the beat oscillator, and are prevented by design precautions in shielding and filtering supply leads. Other "birdies" which show up in the operation of the receiver are likely to result from image interference. An image beating with an on-tune signal, such as an image short-wave b.c. station beating with an amateur 'phone, will produce a heterodyne that can be tuned, and it will tune twice as fast as a regular signal beating against the b.f.o. Normally, tuning will not change the pitch of the heterodyne between two signals that can be heard at the same time. Second, with a single-signal receiver an image will "peak" on the opposite side of zero beat to the side on which normal signals peak as the receiver is tuned. The last

Tuning and Adjusting Receivers

method gives positive image identification with the receiver's beat oscillator on.

If a receiver equipped with a.v.c. blocks on moderately strong signals when the a.v.c. is supposed to be on, check to make certain that it is in operation. If a separate a.v.c. tube is used, check to see that it has not burned out or failed otherwise. If motorboating occurs with a.v.c., a defective tube, open load resistor or leaky by-pass condenser may be at fault. Insufficient time constant (too-small by-pass capacitance) and inadequate r.f. filtering in the a.v.c. feed circuits also can cause this trouble. On excessively strong signals, sufficient to drive the grid of a controlled tube positive, the same effect is likely where a.v.c. is applied to only 1 or 2 stages. It is not probable with the full range a.v.c. available in the better type receivers.

A similar motorboating effect may occur with high-selectivity receivers, especially where a crystal filter is used. It is most noticeable with a.v.c. in operation. Its source is principally instability in the high-frequency oscillator. This trouble can be eliminated by improving the voltage regulation of the supply and the stability of the oscillator.

● AUDIO AMPLIFIERS

Audio amplifiers do not normally give any trouble except from hum and, in high-gain affairs, feedback or "motorboating." Hum can be reduced by making certain that one side of the heater is grounded or, if both sides are free from ground, that both heater leads are bypassed to ground. Hum can be introduced via the first grid of the audio amplifier — if the hum increases as the volume control is turned up, it is probable that the hum is being picked up near the volume control, and the case of the control should be grounded and the grid lead shielded if necessary. Audio hum can also come from an inadequately filtered power supply, in which case an additional 8- μ fd. condenser across the power supply will reduce or eliminate the hum.

Feedback or "motorboating," manifested by a "putt-putt-putt" type of noise in the output, is caused by common impedances in the plate or grid circuits, and can be eliminated by further by-passing of the circuits or by isolation through resistance-capacity combinations. It is rarely encountered when there is sufficient capacity in the output of the power-supply filter.

A noisy audio volume control, indicated by a scraping noise as it is turned, yields to only one solution: replacement.

The tone control, which is simply a variable resistor in series with a fixed condenser which enables the higher audio frequencies to be attenuated, should give no trouble. However,

in the event that turning the tone-control knob doesn't have any effect in reducing the higher audio frequencies, the condenser and resistor should be checked. If the resistor is not open, a larger value of condenser should be added.

● JUDGING RECEIVER PERFORMANCE

Sensitivity: The limiting factor determining the effective sensitivity of a receiver is its own noise ratio. For a given degree of selectivity (band width) this is determined by the gain in the first circuit. With the antenna disconnected, a rough check on this gain can be made by shorting the first tuned circuit of the receiver, leaving the other circuits unaffected, and noting the variation in noise output on a rectifier-type voltmeter connected across the output terminals. The c.w. beat oscillator should be switched on to furnish a carrier in the second detector of a superhet, gain should be full-on and a.v.c. should be switched off. The noise output should decrease with detuning, showing that the first circuit has appreciable impedance as evidenced by thermal agitation voltage. If it does not decrease, the gain of this circuit is negligible. This test should be made on each frequency band. Little change is likely on 14 Mc., but should become appreciable on 3.5 and 1.7 Mc. The test should be made on r.f. amplifier and detector stages. Unchanged noise with the first detector input shorted would indicate that the first detector is the principal source of noise and that there is little gain ahead of it.

Stability: With the beat oscillator on and a steady signal tuned in, vary the manual r.f. gain control rapidly. This will affect the oscillator plate supply voltage, as a result of varying r.f. stage plate current load. The beat note should vary but a few hundred cycles. Another check can be made for temperature stability by noting the change in beat note for a quarter-hour or so after "cold start" of the receiver. Mechanical stability can be checked by jarring the receiver and pushing against its panel and the sides of its cabinet, noting the shift in c.w. beat note.

Band-Spread: Band-spread on each amateur band can be judged by the tuning rate and the calibration spread. Tuning rate is the average number of kilocycles covered with each rotation of the tuning knob, while calibration spread is the average number of kilocycles represented by each of the smallest tuning scale divisions. Tuning rate of approximately 50 kilocycles per knob rotation is generally satisfactory in high-selectivity s.s. receivers, assuming a knob of "natural" size (approximately 2-inch diameter). Calibration spread of 10 kc. or less per scale division is satisfactory for reset and logging purposes.

Transmitter Construction

*Low- and Medium-Power Transmitters — Single-Tube and Push-Pull Amplifiers — Band-Switching Exciters and Amplifiers
E.C.O. Exciters — Antenna Couplers*

IN THE descriptions of apparatus in this chapter not only the electrical specifications but also the manufacturer's name and type number have been given for most components. This is for the convenience of the builder who may wish to make an exact copy of some piece of equipment. However, it should be understood that a component of different manufacture, but of equivalent quality and having the same electrical specifications, may be substituted wherever desired.

In most cases such substitutions will make no major modifications necessary, although slight wiring changes may be needed to take care of different terminal arrangements, etc.

● SIMPLE TETRODE OSCILLATOR TRANSMITTER

The unit shown in the photograph of Fig. 1001 represents one of the simplest types of amateur transmitters. The various parts are assembled on a breadboard which may be purchased already finished at any "dime" store. Rubber feet are tacked on at the corners to elevate the base a half-inch or so to clear mounting screws. A "ground" wire is run from one side of the crystal socket to one side of the coil socket to which all ground connections shown in the diagram of Fig. 1002 are made.

Since parallel plate feed is used, the only exposed high-voltage points are the plate-circuit r.f. choke and the high-voltage power terminal.

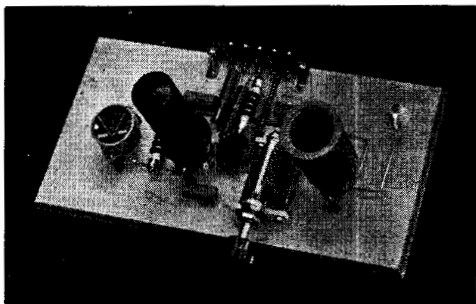

Fig. 1001 — The simple breadboard tetrode oscillator transmitter. The grid r.f. choke is between the crystal and 6L6 and the plate choke to the right of the 6L6. The cathode and screen resistors are to the rear of the 6L6. The blocking condenser C_3 is between the tube and the tank condenser.

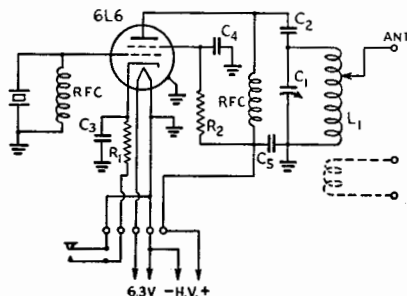

Fig. 1002 — Circuit diagram of the simple tetrode oscillator transmitter.

C_1 — 250- μ fd. midget variable (National STH250).

C_2 — 0.001- μ fd. mica.

C_3, C_4, C_5 — 0.01- μ fd. paper.

R_1 — 200 ohms, 2-watt.

R_2 — 15,000 ohms, 2-watt.

R.f.c. — 2.5-mh. r.f. choke.

L_1 — 1.75 Mc. — 42 turns No. 22 enam., 2 in. long.

3.5 Mc. — 21 turns No. 18 enam., 2 in. long.

7 Mc. — 15 turns No. 18 enam., 2 in. long.

All coils wound on 4-prong, 1½-in. diam. forms.

Grid bias is obtained entirely from the cathode resistance. Either simple voltage feed to a half-wave antenna or an antenna a multiple of one-half wavelength long or link coupling to an antenna tuner (see Fig. 1046) may be used by adding the link winding at the bottom of the form as indicated.

Although a 6L6 is shown in the photograph, a 6V6 might be used at lower plate voltage without circuit alteration. Any available supply delivering up to 450 volts or so may be used with this unit, the power output obtainable increasing with the voltage used. The unit shown in Fig. 1102 is suitable. Since the circuit is not designed for frequency doubling, a separate crystal will be required for each frequency at which it is desired to operate.

Tuning

A milliammeter with a scale of 100 or 200 ma. should be connected in series with the key to assist in tuning. With suitable coil and crystal in place and the high voltage turned on, a rise in plate current should occur when the key is closed. The plate tank condenser C_1 should then be rotated until there is a pronounced dip in plate current at resonance. If the voltage-fed

Transmitter Construction

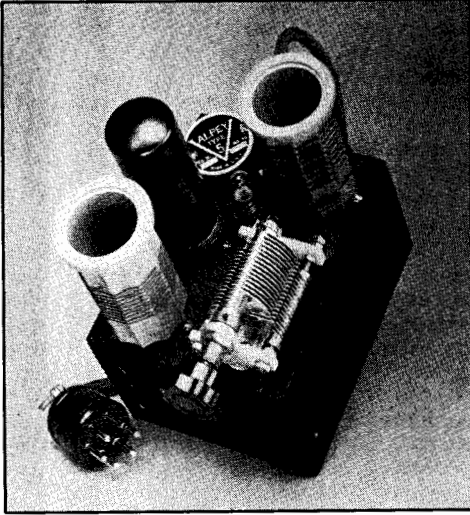

Fig. 1003 — The 6L6 combination oscillator transmitter is built in compact form on a 4-in. by 5-in. by 5-in. chassis or utility box. The plate coil L_2 is behind the tank condenser and the cathode unit plugs into the socket to the left. The tank condenser mounts on the chassis with $\frac{1}{8}$ -in. metal spacers. A clearance hole, lined with a grommet is provided at the rear of the tank condenser for the connection to the coil socket underneath. Six-prong sockets are used for the cathode units and the crystal, 5-prong for the plate coil and octal for the 6L6. All are Amphenol type MIP.

antenna is used, it may now be connected to the antenna terminal and a temporary wire run from the antenna terminal to reach the coil L_1 . Starting at a point one-third or half-way up from the bottom of the coil, scrape the wire at a spot, being careful not to short-circuit turns, and let the antenna wire rest against the bare spot. Tuning the transmitter as before, although less pronounced this time. The tap should be moved gradually toward the top of the coil until only a slight dip in plate current is observed as the plate tank circuit is tuned through resonance. At each adjustment of the antenna tap, the transmitter should be tested to make sure that the circuit keys well. Should a point be reached where it is difficult to get the crystal to start, the tap should be backed off somewhat. It will be found possible to load up the circuit more with certain more active crystals than with others and still maintain good starting and keying characteristics. When a satisfactory point has been found for the tap, it may be soldered in place permanently and a connection made through one of the unused pins on the coil form.

With a 6L6 and a plate supply delivering 400 volts, the screen voltage will run about 250 volts. The tube will draw about 75 ma. non-oscillating, dipping to about 50 ma. at reso-

nance with the antenna disconnected. It should be possible to load up the circuit until the tube draws about 80 ma. at resonance. Under these conditions, the power output on each band should be 15 to 20 watts.

● 6L6 COMBINATION-OSCILLATOR TRANSMITTER

In the low-power transmitter shown in Figs. 1003 and 1005, a combination circuit is used to obtain output at the second harmonic of the

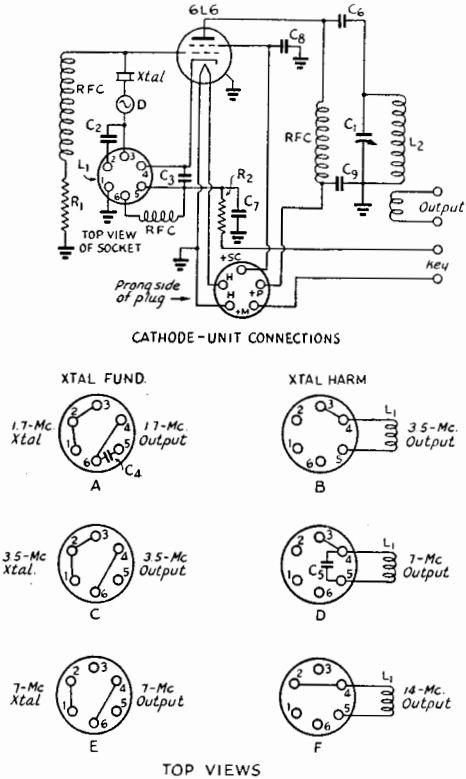

Fig. 1004 — Circuit diagram of the 6L6 combination oscillator transmitter.

- C_1 — 250- μ fd. midget variable (National STH250).
- C_2 — 50- μ fd. mica. D — 60-ma. dial light.
- C_3, C_4, C_5, C_6 — 100- μ fd. mica. R_1 — 20,000 ohms, 1-watt.
- C_7, C_8, C_9 — 0.001- μ fd. mica. R_2 — 200 ohms, 10-watt.
- C_7, C_8, C_9 — 0.01- μ fd. paper. R.f.c. — 2.5-mh. r.f. choke.
- L_1 — For 3.5-Mc. output with 1.75-Mc. crystal — 32 turns, No. 22 d.s.c. close-wound.
- For 7-Mc. output with 3.5-Mc. crystal — 10 turns, 1-in. long.
- For 14-Mc. output with 7-Mc. crystal — 6 $\frac{1}{2}$ turns, 1-in. long.
- All above wound with No. 22 enam. on 1 $\frac{1}{2}$ -in. diam. 6-pin forms.
- L_2 — 1.75-Mc. output — 40 turns No. 22 enam., 1 $\frac{1}{2}$ -in. long.
- 3.5-Mc. output — 21 turns No. 18 enam., 1 $\frac{1}{2}$ -in. long.
- 7-Mc. output — 11 turns No. 18 enam., 1-in. long.
- 14-Mc. output — 6 turns No. 18 enam., 1-in. long.
- All above wound on 1 $\frac{1}{2}$ -in. diam., 5-pin forms.

The Radio Amateur's Handbook

crystal frequency as well as at its fundamental frequency. Thus, a crystal of properly-chosen frequency may be used to obtain output in two bands; a 3.5-Mc. crystal, for instance, may be used to operate in the 7-Mc. as well as the 3.5-Mc. band.

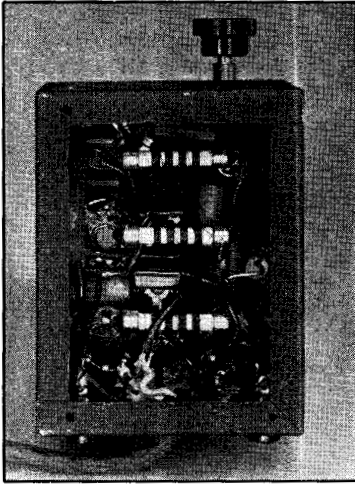

Fig. 1005 — Assembly of small parts underneath and wiring is simplified by the fact that the top plate is removable, making it possible to do most of the work outside the box. Filament and other low-potential wiring, resistors and by-pass condensers are placed down close to the chassis, while r.f. chokes and high-potential r.f. leads are kept well-spaced from the metal. Insulating lug strips anchor the r.f. chokes, etc., and the termination of the power cable. Insulated pin jacks at the rear are used for the key and link-output terminals.

The circuit, shown in Fig. 1004 combines the features of the "grid-plate" oscillator, which has been found to possess advantages over most others for operation with maximum output at the crystal frequency, and those of the Tri-tet circuit which is excellent for obtaining output at the second harmonic. Both circuits possess characteristics approaching those of an oscillator-amplifier in that the oscillating circuit proper is isolated and, therefore, operates more or less independently of the output load circuit. Change from one circuit to the other is made automatically by plugging in the proper units in the cathode circuit. The 60-ma. dial light, *D*, is in series with the crystal to serve as an indicator of crystal r.f. current and as a safety fuse in case the wrong combination of units is plugged in by mistake.

The unit is built up in compact form, since it is designed to combine with the power supply of Fig. 1102 and the antenna tuner of Fig. 1046 to form a single standard 17-inch rack unit. (See Fig. 1305.) The top of the box is removable so that only the connections to the key

and output terminals and the power-supply lug strip need be made after the top plate is fastened to the box. It will be necessary to make one or two small cutouts along the top edge of the box to clear the sockets. The unit is designed to connect to the power supply through a 5-wire cable as shown in Fig. 1306.

Tuning

Reference should be made to the table of cathode units in Fig. 1004 to determine which unit to use depending upon the frequency-band of the crystal and the band in which power output is desired. It will be noted that there is no winding on the cathode-unit coil forms shown for output at the crystal fundamental, the empty coil form merely being strapped to close the required circuits. The 1.75-Mc. unit contains an extra 100- μ fd. condenser which connects in parallel with C_3 when the unit is plugged in. The cathode units for use when the circuit is to double frequency have each a winding as indicated. If, for example, we wish to operate in the 3.5-Mc. band with a 3.5-Mc. crystal, unit *C* is plugged into the cathode-circuit socket and the plate coil for 3.5-Mc. in the plate-coil socket. If we were to operate at 3.5 Mc. with a 1.75-Mc. crystal, unit *B* would be used in the cathode circuit and the same plate coil used. 7-Mc. output from a 3.5-Mc. crystal will be obtained with unit *D* in the cathode socket and the 7-Mc. plate coil, etc.

The use of fixed values in the cathode circuit has eliminated any manual control for this circuit. Therefore, it is necessary only to tune the plate circuit for output on any given band. Any plate voltage up to 500 may be used, the power output increasing with plate voltage increase.

Screen voltage may be taken from a voltage divider resistance across the output of the plate-voltage supply. It is preferable to locate the voltage-divider resistance in the power-supply unit as described under Fig. 1306 rather than in the oscillator unit itself to reduce heating effects. The divider tap should be set so the screen voltage does not exceed 300 volts under loaded operating conditions. Tuning the transmitter is merely a matter of tuning the plate circuit to resonance and adjusting the load. When operating at the crystal fundamental, oscillations will start when the plate circuit is tuned only approximately at resonance, the plate current dipping as usual at resonance. With a 500-volt plate supply and the screen voltage set at 250 volts, the plate current when the circuit is not oscillating will run approximately 80 ma., dropping to 40 ma. or so at resonance. As the antenna is coupled, the dip in plate current at resonance will become less pronounced, disappearing almost entirely when the circuit is fully loaded. It is

Transmitter Construction

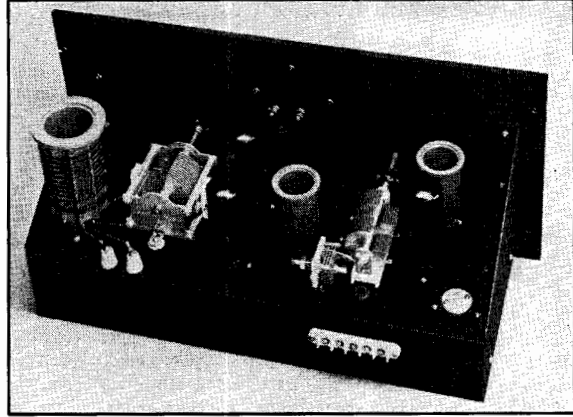

Fig. 1007 — The chassis is 7-in. by 17 in. by 3 in. All sockets except that for the final tank coil are submounted. The cathode coil, L_1 , is in front of the oscillator tube. The final tank condenser, C_3 , to the left is mounted on insulating buttons and spacers to bring the shaft up level with that of the dual condenser. Amphenol type MIP sockets are used throughout, a 6-prong with two groups of three prongs wired together for the crystal socket. One-half-inch holes lined with grommets are drilled for the high-potential leads which must pass through the chassis. The balancing condenser, C_2 , is mounted at the rear of C_1 .

best to use some sort of indicator in the load circuit, such as an r.f. ammeter in the feeder, to assist in tuning for maximum output. Heavy loading should not affect the oscillator's keying characteristics. When loaded so that the tube draws 75 ma., the output should be close to 20 watts on any of the three bands under the conditions described.

The tuning procedure, when operating at the crystal's second harmonic, is similar. Oscillations should start as soon as the plate voltage is applied and the key closed, regardless of the setting of the tank condenser. Under the conditions described previously, the plate current should dip to 40 or 50 ma. at resonance with the circuit unloaded. Adjusting the load so that the plate current runs 80 to 90 ma. at resonance, the output at the harmonic frequency should be 12 to 15 watts. Here also, loading should have no effect upon keying characteristics. Under normal conditions the

crystal-current dial lamp should show no more than a medium-bright glow. A bright light or a burn out will indicate a fault in the circuit or a mistake in the cathode unit selected.

As indicated in Fig. 1004, coupling to the antenna circuit is by means of a link winding wound on the plate tank-coil form below the plate winding. The number of turns in this link winding and the distance from the plate coil should be adjusted to give the desired coupling for each band. Usually 3 or 4 turns spaced about $\frac{1}{4}$ -in. from the plate winding will be found sufficient.

● A TWO-STAGE 6L6 TRANSMITTER

In the two-stage transmitter shown in the photographs of Figs. 1006, 1007, and 1009, a 6L6 or 6V6 crystal oscillator is used to drive an output stage employing a pair of 6L6's. The oscillator circuit (Fig. 1008) is arranged so that it is operated as a Tri-tet with fixed cathode tuning when it is desired to double frequency in the plate circuit of the oscillator while, by short-circuiting the cathode tank circuit, it is operated as a tetrode oscillator for obtaining oscillator output at the crystal fundamental.

The output stage is arranged primarily as a push-push doubler so that frequency may be doubled in this stage as well as in the oscillator when required. Thus, output frequencies in three bands may be obtained from a single crystal of properly-chosen frequency.

When the output stage is to be operated as a straight amplifier, the heater of one of the tubes is turned off by opening SW_2 which also cuts in extra resistance in series with the high voltage to the oscillator plate to reduce the output of the oscillator, thereby avoiding over-driving of the single tube with consequent reduction in output. The idle tube acts as a neutralizing condenser for the other.

The plate circuit of the oscillator is split to

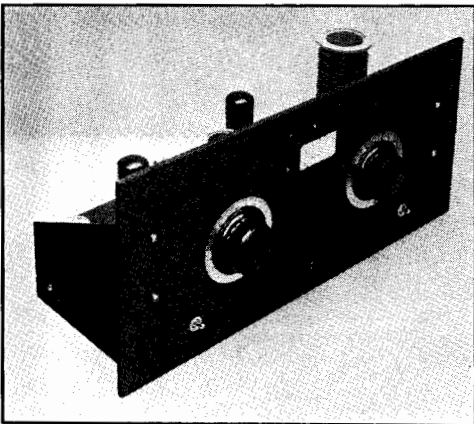

Fig. 1006 — The panel of the two-stage 6L6 transmitter is $8\frac{3}{4}$ by 19 inches. The toggle switch at the left is SW_1 and the one at the right SW_2 . The meter switch is below the meter.

The Radio Amateur's Handbook

Crystal & Cath.	Osc. Plate	Output Circuit	SW ₁	SW ₂
1.75 Mc.	1.75 Mc.	1.75 Mc.	Closed	Open
1.75 Mc.	1.75 Mc.	3.5 Mc.	Closed	Closed
1.75 Mc.	3.5 Mc.	3.5 Mc.	Open	Open
1.75 Mc.	3.5 Mc.	7 Mc.	Open	Closed
3.5 Mc.	3.5 Mc.	3.5 Mc.	Closed	Open
3.5 Mc.	3.5 Mc.	7 Mc.	Closed	Closed
3.5 Mc.	7 Mc.	7 Mc.	Open	Open
3.5 Mc.	7 Mc.	14 Mc.	Open	Closed
7 Mc.	7 Mc.	7 Mc.	Closed	Open
7 Mc.	7 Mc.	14 Mc.	Closed	Closed
7 Mc.	14 Mc.	14 Mc.	Open	Open
7 Mc.	14 Mc.	28 Mc.	Open	Closed

provide for push-pull feed to the output stage. C₂ is used to compensate for the unbalancing effect of the output capacity of the oscillator

tube connected across the opposite side of the plate circuit.

Meter switching is provided so that a single milliammeter may be used to check all plate and grid currents. The shunting resistances R₁₄, R₁₅ and R₁₆, which are connected across the 10-ma. meter when reading grid currents, are sufficiently high in value to have negligible effect upon the original calibration of the meter. R₁₂ and R₁₃ are wound with copper wire and the resistance adjusted to give a meter-scale multiplication of 10 and 30 respectively, so that the original scale of 10 ma. will be increased to 100 ma. for checking oscillator cathode current and to 300 ma. for checking amplifier cathode current. Information on making these shunts will be found in Chap.

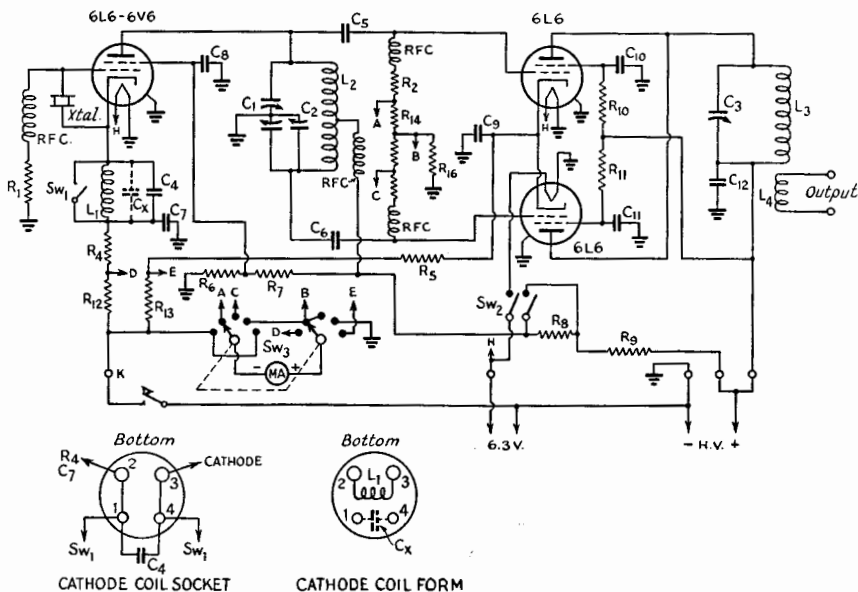
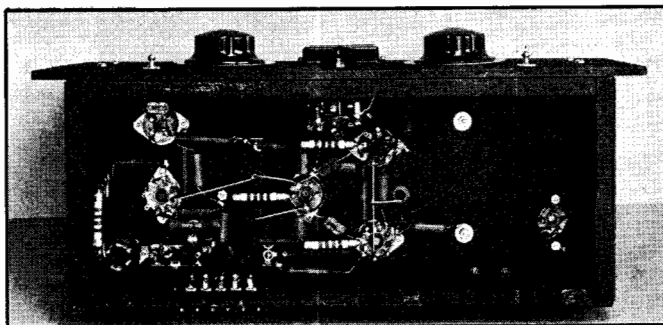

Fig. 1008 — Circuit diagram of the two-stage 6L6 transmitter.

- C₁ — Split-stator midget condenser, 140 μ fd. per section (Hammarlund MCD140S).
- C₂ — 25- μ fd. midget (Cardwell ZR25AS).
- C₃ — 260- μ fd. variable condenser (Hammarlund MTC-250-C).
- C₄ — 100- μ fd. mica.
- C₅, C₆ — 150- μ fd. mica.
- L₁ — 1.75-Mc. crystals — 32 turns No. 22 d.s.c., close-wound.
- 3.5-Mc. crystals — 10 turns No. 22 d.s.c., 1-in. long.
- 7-Mc. crystals — 6½ turns No. 22 d.s.c., ¾-in. long.
- Above coils wound on Hammarlund 1½-in. diam., 4-pin coil forms.
- L₂ — 1.75 Mc. — 68 turns No. 24 d.s.c., close-wound
- 3.5 Mc. — 36 turns No. 24 d.s.c., 2-in. long.
- 7 Mc. — 22 turns No. 22 d.s.c., 1½-in. long.
- 14 Mc. — 10 turns No. 22 d.s.c., 1½-in. long.
- R₈, R₉ — 5000 ohms, 10-watt.
- R₁₀, R₁₁ — 10,000 ohms, 10-watt.
- R₁₂ — Meter multiplier resistance, 10 times.
- R₁₃ — Meter multiplier resistance, 30 times.
- R₁₄, R₁₅, R₁₆ — 50 ohms, ½-watt.
- SW₁ — S.p.s.t. toggle switch.
- SW₂ — D.p.s.t. toggle switch.
- SW₃ — Two-gang, 5-contact tap switch (Mallory 1326L).
- Above coils wound on Hammarlund 1½-in. diam., 5-prong coil forms, centertapped.
- L₃ — 1.75 Mc. — 28 turns No. 18 enam., 2¼-in. diam., 1½-in. long.
- 3.5 Mc. — 16 turns No. 14 enam., 2¼-in. diam., 2¼-in. long.
- 7 Mc. — 10 turns No. 14 enam., 2¼-in. diam., 2¼-in. long.
- 14 Mc. — 6 turns No. 14 enam., 2¼-in. diam., 2¼-in. long.
- 28 Mc. — 3 turns No. 14 enam., 1½-in. diam., 1¼-in. long.

Transmitter Construction

Fig. 1009 — High-potential r.f. leads should be made as short as possible and kept well-spaced from the chassis. By-pass condensers and resistors are fastened with one end soldered to the point of connection and the other end grounded to the nearest mounting screw or supported by a fibre lug strip where insulation is required. The meter-shunting resistances are soldered directly to the switch points. The cathode-circuit condenser, C_4 is connected across the socket of L_1 , with the short-circuiting switch, SW_1 directly in front.



17. The cathode circuits of both stages are keyed simultaneously.

The amplifier will handle a power input of 80 to 90 watts when both tubes are in use, or inputs up to 50 watts when the single tube is used as a neutralized amplifier. At a voltage at the input terminal of 475 volts, which should not be exceeded (the power-supply shown in Fig. 1104 is suitable), output power between 40 and 45 watts is obtainable from the two tubes as doublers at 3.5, 7 and 14 Mc. and 22 watts at 28 Mc. The single tube, operating as a straight amplifier, will deliver 30 to 35 watts. When lower voltages are used, power output will be proportionately reduced.

Coils

Coils for L_1 and L_2 are wound on Hammarlund $1\frac{1}{2}$ -inch diameter forms, following the dimensions given under the circuit diagram. Four-prong forms are used for L_1 and 5-prong forms for L_2 . L_2 is tapped at the center in each case. Connections for the cathode-circuit socket and coil forms are shown in Fig. 1008. In the coil for use with 3.5-Mc. crystals only, an extra 100- μ fd. mica condenser, C_x , is connected across the two unused pins of the form. This is automatically connected in parallel with C_4 when the 3.5-Mc. cathode coil is plugged in. All coils for L_3 , excepting the one for 28 Mc. are wound on Hammarlund 5-prong, $2\frac{1}{4}$ -in. diameter forms. The coil for 28 Mc. is wound on a $1\frac{1}{2}$ -in. form.

Tuning

The accompanying table shows the various combinations which may be used to obtain output in the desired band with any particular crystal and as indicates the positions in which SW_1 and SW_2 should be thrown for each combination. For preliminary testing, the high-voltage connection to the output stage should be disconnected at the terminal. After the operator has become accustomed to tuning the transmitter, this will be unnecessary. Both switches should be closed and a combination of crystal and coils chosen which will permit

the oscillator plate circuit to be tuned to the crystal frequency and the output circuit to the second harmonic of the crystal frequency; i.e., 3.5-Mc. crystal, 3.5-Mc. coils for L_1 and L_2 and 7-Mc. coil for L_3 . The meter switch should be thrown to the first position where the meter reads oscillator cathode current. As soon as the plate voltage has been applied and the key closed, C_1 should be tuned for a dip in plate current. When this has been found, the meter switch should be turned to the fourth position so that the meter will read total grid current to the output stage. After C_1 has been adjusted for maximum grid-current reading, the switch may be set at the second position where the meter reads the grid current for one tube. This reading should be compared with that for the other tube by turning to the third switch position. C_2 should now be adjusted in small steps, following each step with a retuning of C_1 for maximum grid current to one tube and then switching the meter over to compare it with that of the second tube. Eventually a point will be found where the two individual grid currents are equal and C_2 will require no further attention. The meter switch may now be turned to the last position, the plate voltage applied to the output stage and C_3 tuned for maximum plate-current dip.

Adjustments when doubling frequency in the oscillator are similar, except that SW_1 will be open instead of closed. In operating the single tube in the amplifier stage for straight amplification, adjustments are the same except that SW_2 is open and the plate current will not run so high. Grid current will, of course, flow but to one tube. Since the range of C_3 may be great enough with certain coils to cover more than one band, care should be taken to make sure that the correct plate-current dip is selected.

A link winding should be wound below L_3 on the same form for coupling to the link input of a following amplifier or to a suitable antenna tuner.

Typical values of voltages and currents for a supply voltage of 475 are given below. They are

The Radio Amateur's Handbook

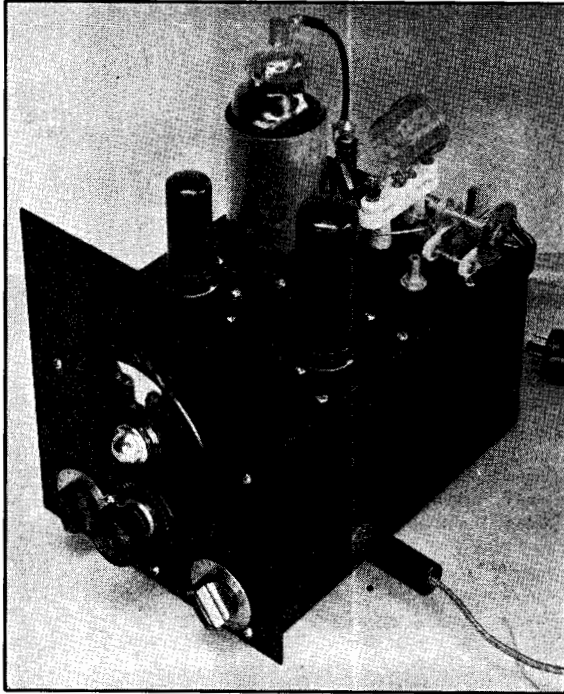

Fig. 1010 — A steel utility box, 5 in. by 6 in. by 9 in., is used as the chassis. A standard 7-by-8 steel panel is fastened on the front. The small knob to the left controls the vernier for small frequency changes, while the one to the right operates the keying switch. The shaft of the 6L6 paddler is in front of the 802 plate paddler at the rear.

for tuned and loaded-circuit conditions. Loading of the output amplifier should not be carried beyond the point giving normal tube life. Those indicated at (a) are typical when a single tube is operating in the output stage, while those indicated at (b) are for two tubes in the final.

Oscillator

Plate-cathode voltage (a) 125-140 (b) 175-250
Screen-cathode voltage (a) 75-90 (b) 100-140
Cathode current (a) 15-25 ma. (b) 30-45 ma.

Output Stage

Plate-cathode voltage (a) 450 (b) 450
Screen-cathode voltage (a) 360-375 (b) 300-325
Cathode current (a) 95-120 ma. (b) 160-200 ma.
Grid current (a) 1-1.5 ma. (b) 1.5-2.5 ma. per tube

● AN E.C.O. EXCITER UNIT

In discussing self-controlled oscillators in Chap. 5, the importance of care in design and construction was stressed. In the unit shown in Figs. 1010 and 1012 the various factors which contribute toward instability have been taken into consideration. The 6F6 was chosen for the oscillator tube since it is remarkably free from "microphonics" or changes in frequency caused by mechanical jarring. It is followed by a 6L6 frequency doubler to pro-

vide isolation between the oscillator and following stages. The 802 is used in the output stage to add further to the isolation and to provide a means of obtaining a power output from the unit of 15 to 20 watts or more at full voltage — a power level comparable to that of a power crystal oscillator. This type was chosen in preference to the 807 because of the latter's tendency toward parasitic oscillations which are often responsible for poor e.c.o. performance. It is considered preferable to build the isolating and power stages into the e.c.o. unit rather than to feed the oscillator into existing stages of a transmitter which may not be designed for the purpose.

It will be noticed from the circuit diagram of Fig. 1011 that the grid circuit of the e.c.o. and the plate circuits of the 6L6 and the 802 are tuned simultaneously by a gang of three midget condensers. These circuits may be tuned individually by omitting C_5 and C_6 and substituting 100- μ fd. condensers for C_7 and C_8 . The slight additional cost of the ganging is well worth while, however. Parallel plate feed is used throughout to permit direct grounding of the various tuned-circuit components. The separate cathode winding, L_2 , instead of a tap on L_1 facilitates a convenient keying circuit for the oscillator.

The unit is designed to give output in two bands — either the 1.75- and the 3.5-Mc. bands or the 3.5- and the 7-Mc. bands depending upon the choice of the constructor. The grid-circuit inductance of the oscillator and the plate-circuit inductance of the 6L6 are permanently mounted and only the plate coil of the 802 needs changing for operating as a straight amplifier or as a doubler. For 1.75- and 3.5-Mc. output, the oscillator operates at 875 kc., the 6L6 at 1.75 Mc. and the 802 at either 1.75 or 3.5 Mc. For 3.5 and 7-Mc. output the oscillator operates at 1.75 Mc., the 6L6 at 3.5 Mc. and 802 at either 3.5 or 7 Mc.

The tuning range is adjusted so that the 1.75- and 3.5-Mc. bands are spread over about 90 per cent of the dial scale. At 7 Mc. only the lower-frequency portion of the range is useful. However, no difficulty should be experienced in setting quickly within audibility of a chosen frequency — even at the 28-Mc. harmonic. C_4 is provided as a handy means of setting the frequency to zero beat or for making small frequency changes.

Although zero temperature-coefficient condensers are specified for the oscillator padding capacity, (C_1 and C_2), an ordinary 500- μ fd.

Transmitter Construction

Construction

mica condenser, or one of the silvered type, may be substituted if maximum reduction in frequency drift is not considered important. Since the tubes are mounted on top of the unit and all voltage-dropping resistor networks are external to the unit, the variation in temperature inside the box is reduced substantially to that of the operating room.

The switch in the keying circuit has three positions. In the first position, the oscillator and 6L6 stages operate through the key to produce a monitoring signal for setting frequency. In the second position, both oscillator and output stages are keyed for break-in operation. For those who prefer buffer keying, the third position switches the oscillator to continuous operation, while the 802 alone is keyed.

It may also be well to mention that the unusually large value of plate blocking capacity for C_{19} is required in this instance to detune a parasitic circuit set up by the r.f. chokes in the 6L6 grid and plate circuits. The r.f. choke in the cathode circuit of the 802 eliminated a trace of r.f. in the keying leads.

The unit is constructed with a steel utility box 5" by 6" by 9" as the chassis. Both top and bottom plates of this box are removable which facilitates construction, since all but a few components are mounted on the top plate. The three condensers of the tuning gang are first coupled together and set in place with the shaft running along the center of the plate and the shaft of the first condenser (C_3) protruding far enough in front for the dial. The tube sockets are then placed in the positions shown in the photographs, the sockets for the 6F6 and 802 on one side and the 6L6 on the other side opposite the 6F6. The coil forms and the 6L6 padder, C_7 , are then placed, spacing the coil forms a half-inch or so from the plate with spacers. The plate-circuit components for the 802 are then arranged on top of the base so that their mounting screws will not interfere with the components placed below. The plate-circuit r.f. choke and blocking condenser, C_{12} , are behind the 802 with a National feed-

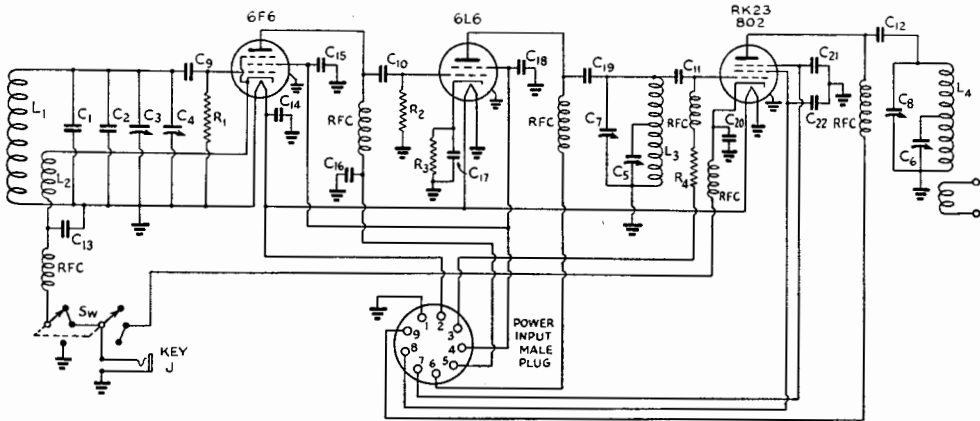

Fig. 1011 — Circuit diagram of the e.c.o. exciter.

- C_1, C_2 — 250- μ fd. fixed, zero-temp. coefficient — (Centralab 816Z).
 C_3 — 200- μ fd. midget variable (Hammarlund MC200M).
 C_4 — 15- μ fd. midget variable (Hammarlund HF15X).
 C_5, C_6 — 50- μ fd. midget variable (Hammarlund MC50M).
 C_7 — 50- μ fd. midget variable (Hammarlund HF50).
 C_8 — 50- μ fd. midget variable (Hammarlund MC50S).
 C_9, C_{10} — 100- μ fd. mica.
 C_{11} — 250- μ fd. mica.
 C_{12} — 0.001- μ fd. mica.
 $C_{13}, C_{14}, C_{15}, C_{16}, C_{17}, C_{18}, C_{19}, C_{20}, C_{21}, C_{22}$ — 0.01- μ fd. paper.
 J — Single open-circuit jack.
 R_1 — 0.1 meg., $\frac{1}{2}$ -watt.
 R_2 — 0.1 meg., $\frac{1}{2}$ -watt.
 R_3 — 400 ohms, 1-watt.
 R_4 — 50,000 ohms, 1-watt.
 R.F.C. — 2.5-mb. r.f. choke.
 Sw — Two-circuit, 3-position switch (Mallory 3223J).
 L_1 — 0.875 Mc. — 60 turns No. 24 enam., close-wound.
 1.75 Mc. — 26 turns No. 22 d.s.c., $\frac{1}{8}$ -in. long.
 L_2 — 0.875 Mc. — 20 turns No. 24 enam., wound turn

- for turn over ground end of L_1 , same direction.
 1.75 Mc. — 9 turns No. 22 d.s.c., wound turn for turn over ground end of L_1 , same direction.
 L_3 — 1.75 Mc. — 85 turns No. 30 d.s.c., close-wound, tapped at 22 turns from plate end.
 3.5 Mc. — 37 turns No. 24 d.s.c., close-wound, tapped at 10 turns from plate end.
 L_4 — 1.75 Mc. — 60 turns, $1\frac{1}{4}$ -in. diam., $1\frac{1}{2}$ -in. long (National AR160E coil with 12 turns removed, tapped at 12 turns from plate end) (105 μ ys., tapped at $\frac{1}{5}$ of total number of turns from plate end).
 3.5 Mc. — 32 turns, $1\frac{1}{4}$ -in. diam., $\frac{1}{2}$ -in. long, tapped at 11 turns from plate end (National AR80E coil with 24 turns removed, tapped at 11 turns from plate end) (26 μ ys., tapped at $\frac{11}{32}$ of total number of turns from plate end).
 7-Mc. — 19 turns, $1\frac{1}{4}$ -in. diam., 1-in. long, tapped at 8 turns from plate end (National AR40E with 9 turns removed, tapped at 8 turns from plate end) (8.8 μ ys., tapped at $\frac{8}{19}$ total number of turns from plate end).
 Note: L_1, L_2 and L_3 wound on Millen 1-in. diam. forms, no pins.

The Radio Amateur's Handbook

through point for bringing the high-voltage lead up through the base to the bottom end of the choke.

Small components are then placed in the nearest available remaining open spaces. The National R100U r.f. chokes are convenient for mounting in restricted space. The one fastened on one of the mounting screws of the 6F6 socket is the one in the 6F6 cathode lead to the key, while the one to the side of the socket is the plate-circuit choke. The 6L6 plate-circuit choke is next to the 6L6 plate coil and the one fastened to the 802 socket-mounting screw is in the 802 grid circuit. The horizontally mounted choke is in the 802 cathode circuit and the end toward the key switch is fastened to a small insulated lug strip, the other end being connected directly to the cathode terminal of the socket.

The two fixed condensers, C_1 and C_2 , which look like resistors, are supported by their leads connected across the terminals of C_3 . They are braced against vibration by binding together at each end with rubber bands. A stiff wire soldered to the lead between the rotor of C_3 and the top of L_1 is fastened to the ends of the condensers with Duco cement to provide further

bracing. C_9 is supported by its leads between the stator terminal of C_3 and the 6F6 grid terminal at the socket. C_{10} is also supported by its leads between the top of the oscillator plate-circuit choke and the grid terminal of the 6L6. Similarly, C_{11} is suspended between the stator terminal of C_7 and the grid terminal of the 802 socket, passing underneath the condenser shaft but spaced from the chassis. By-pass condensers are tucked in wherever space may be found near the terminal to be by-passed.

The high-potential r.f. wiring may be done with a few short lengths of No. 14 wire. All power wiring is done with push-back wire laid close to the chassis and cabled along one side to the nine-pin male power-input plug mounted on the rear wall of the box. Power leads for the 802 suppressor, screen and plate may be brought up to the power-input plug but should not be soldered to the plug until preceding stages have been tested.

A standard steel panel, 7 by 8 inches is fastened to the front end of the box. C_4 and the key-circuit switch are mounted in the lower corners. The key jack is mounted on the side of the box. Shielded single-conductor wire should be used for all key-circuit wiring from the r.f. chokes to the key jack and should also be used for the external wiring from the plug to the key to prevent r.f. pick-up. The outside shield is used for the grounded side of the circuit. Wiring to the key switch and jack and to the power-input plug may be done before the unit is placed in the box, so that only the single connection between the stator of the vernier, C_4 , and the top of L_1 need be made after the top is fastened in place. After the top has been screwed down, an inspection of the edges should be made to make sure that it is secure at all points. Any gaps between the top and the box should be closed up with extra screws at the proper points.

A small metal scale is fastened to the mounting collar of C_3 and a small pointer knob provided so that this condenser may be returned immediately to the proper setting for each of the two output bands. The shaft of C_7 is turned with a small screwdriver and, once adjusted, needs no further attention for operation in either band. Output is taken directly from the link terminals on the plug-in base of L_4 .

Tuning

If dimensions have been closely followed, no adjustment of the tracking taps on L_3 and L_4 should be required. The procedure for adjusting for 3.5- and 7-Mc. output will be described in detail. Adjustment for 1.75- and 3.5-Mc. output with the coils for these bands is carried out in a similar manner. With the key switch thrown in the last position, placing the 6F6

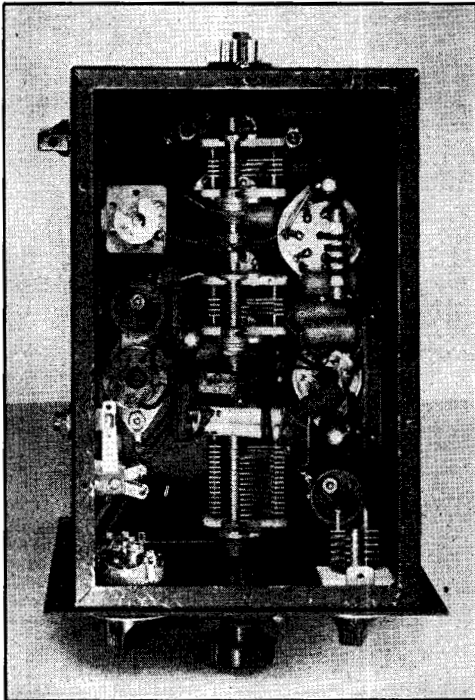

Fig. 1012 — Bottom view with bottom plate removed showing arrangement of components under the chassis. The removable top and bottom plates make the assembly easy. Shielded single conductor is used for the key-circuit leads.

Transmitter Construction

and the 6L6 only in operation, the plate voltage may be applied with the key open. This should produce a continuous signal from the first two stages by which the tuning range of the oscillator may be checked with a receiver. Care should be exercised in distinguishing the signal from its image on a superhet or from blocking on any type receiver with a large receiving antenna. If the range of 3500 to 4000 kc. is not covered, it will be necessary to remove a turn from L_1 if 4000 kc. is not reached, or to add a turn if 3500 kc. is not reached. Plate current to the 6F6 should run at approximately 9 ma. with a plate voltage of 300 and screen voltage of 150.

The next step is that of trimming up the plate circuit of the 6L6. This is done with all voltages (except heater) removed from the 802 and with a low-range milliammeter in the external grid return lead to ground. With the oscillator set at or about 4000 kc., the key switch is set at the third position and the key closed. Adjusting the 6L6 plate circuit to resonance by turning C_7 with a screwdriver should produce a reading of about 4 ma. on the grid-current meter. The oscillator should then be tuned to 3500 kc. and, after noting carefully the setting of C_7 , it should again be adjusted for maximum grid current. If readjustment of C_7 at 3500 kc. produces an increase of grid current of more than 1 ma., the tap on L_3 will have to be readjusted. It should be moved a turn toward the plate end of the coil if an increase in the capacity of C_7 is necessary to restore resonance; or a turn in the opposite direction if a decrease in the capacity of C_7 is required. At resonance, plate current to the 6L6 will run approximately 15 ma. at plate and screen voltages of 300 and 150, respectively. This stage is not keyed and runs continuously, there being but slight difference in the plate current whether the key is closed or open.

Lining up of the 802 stage is done in a similar manner with all voltages applied to the 802 and a load of some sort coupled to the output link. Resonance here is indicated by the customary dip in plate current. When the circuit is tracking, there should be but very slight difference in the setting of C_3 for resonance over the entire band. After the tracking for 3.5 Mc. has been adjusted, the 7-Mc. coil may be plugged in the output circuit. In this case, the circuit need track only between 7300 and 7000 kc., of course. With proper coupling, the plate current at resonance may be run up to the rated 60 ma.

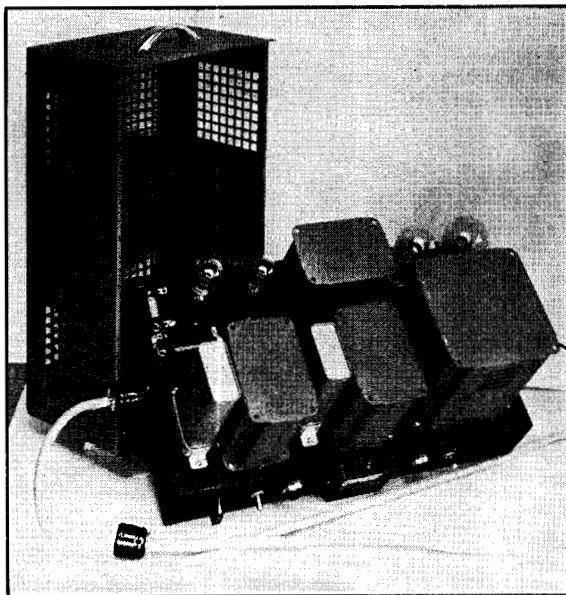

Fig. 1013 — Top view of power supply with cover removed. All high-voltage points are unexposed. The VR150's are to the left in back of the voltage-divider resistances which are mounted on top for ventilation.

Power Supply

A proper power supply is of utmost importance if chirpy keying and changes in frequency with changes in line voltage are to be avoided. The power-supply unit pictured in Figs. 1013 and 1015 has been designed particularly for use with the e.c.o. exciter. Referring to the circuit diagram of Fig. 1014, the VR150 regulator tubes provide constant voltages of 300 for the plates of the 6F6 and 6L6 and 150 for the screens of these two tubes. Close regulation of the voltages applied to the 802 is not required. Screen and suppressor voltages of approximately 250 and 100 respectively are obtained from the voltage-divider resistance R_2 . Precaution against the pick-up of r.f. through the supply line or power supply itself or leads to the r.f. unit has been taken by the use of an r.f. filter in the input line, a shielding cover and a shielded 8-wire cable between power-supply and r.f. units. A milliammeter and switch are provided for checking the various currents and signal lamps and switches for the filament- and plate-supply circuits. The shield of the cable, connected to pin No. 1, is used for the ground, negative high-voltage and one side of the filament circuit. The cable plugs into a 9-prong Amphenol female outlet set in one end of the chassis. Since the power-supply has a rating of 250 ma. and the total current drawn by the e.c.o. unit will be somewhere between

The Radio Amateur's Handbook

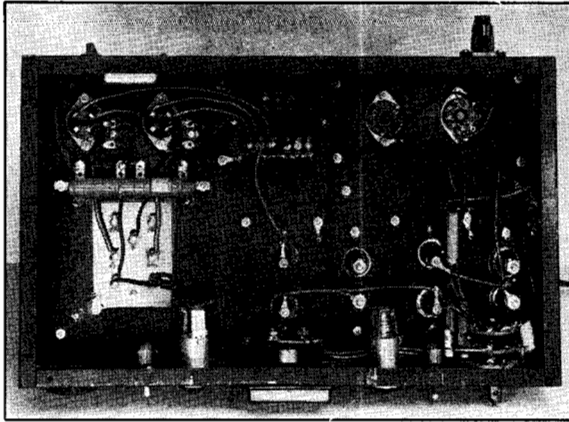

Fig. 1015 — Bottom view of power supply showing line-filter and hash-filter chokes and the meter switching. The terminal at the rear of the chassis is for external connection to the 600-volt line.

100 and 125 ma. at full load, another stage requiring 100 to 150 ma. at 600 volts may be operated from this supply, and an external terminal for this purpose has been provided at the rear of the chassis.

The resistors R_3 , R_4 , R_5 , R_6 and R_7 are shunts for the 30-ma. meter. R_6 and R_7 are multiplying resistors to increase the range of the meter to 90 ma. for measuring the 802 plate current

and to 240 ma. for measuring the current in the lead to the external circuit. These two shunts are wound on a short length of fibre rod $\frac{1}{4}$ -in. in diameter with copper wire, following the procedure outlined in Chapter 17.

At some sacrifice in voltage regulation of the supply to the 802 and loss of independent control of filament and plate voltages, a suitable supply may be built at a lower cost. T_1 and T_2 may be replaced by a single combination transformer delivering 600 volts a.c. each side of center, 200 ma. for the high-voltage winding and having 6.3-volt, 3-amp. and 5-volt 3-amp. windings for the filaments. A suitable transformer is the UTC-S41. The filter chokes may be replaced by a pair rated at 120 ma., such as the Thordarson T53C19, and the 866 Jr. half-wave rectifiers by a single type 83 full-wave rectifier. Condenser input will be required and a double-unit 8- μ fd., 450-volt electrolytic condenser with the sections connected in series may be used. C_3 and C_4 may be replaced with 600-volt 8- μ fd. electrolytics. The chassis cover may in many cases be eliminated if the power supply is kept well removed from r.f. fields. The hash-filter chokes may be dispensed with if no interference from rectifier

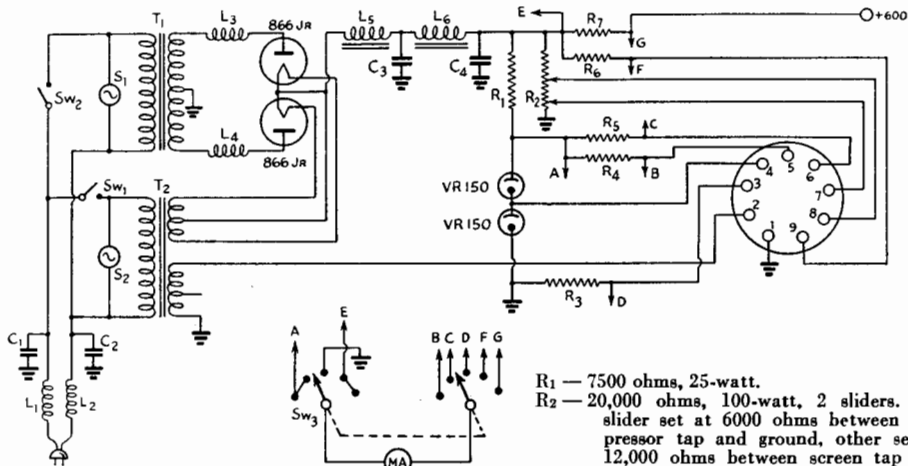

Fig. 1014 — Circuit diagram of the power supply for the e.c.o. unit.

- C_1 , C_2 — 0.1- μ fd. — double-unit, 400-volt paper condenser.
- C_3 , C_4 — 4- μ fd., 1000-volt filter condensers.
- L_1 , L_2 — Line filter chokes (Ohmite Z-20, double unit).
- L_3 , L_4 — Hash filter chokes (Millen 77866).
- L_5 — 5/25 hys., 225-ma. swinging filter choke (UTC-S32).
- L_6 — 20-hys., 225-ma. smoothing filter choke (UTC-S31).
- MA — D.C. milliammeter, scale 0 — 30 ma. (Triplett type 326).

- R_1 — 7500 ohms, 25-watt.
- R_2 — 20,000 ohms, 100-watt, 2 sliders. One slider set at 6000 ohms between suppressor tap and ground, other set at 12,000 ohms between screen tap and ground.
- R_3 — 50 ohms, $\frac{1}{2}$ -watt.
- R_4 , R_5 — 50 ohms, 1-watt.
- R_6 — Multiplying resistor wound with No. 28 copper wire to give scale multiplication of 3.
- R_7 — Multiplying resistor wound with No. 26 copper wire to give scale multiplication of 8.
- S_1 , S_2 — 110-volt signal lamps.
- SW_1 , SW_2 — S.p.d.t. toggle switches.
- SW_3 — Two-gang, 5-contact switch (Mallory 1326L).
- T_1 — Plate transformer, 600 volts d.c., 250-ma. (UTC-S45).
- T_2 — Filament transformer, 6.3 volts, 5 amp., 5 volts, 6 amp. (UTC-S67).

Transmitter Construction

hash is experienced, although they are good insurance against roughening of the oscillator signal from this source.

Should the full output from the 802 not be required, a power supply of considerably lower voltage might be used. If a voltage lower than 300 is used, the voltage regulator tube between the screen tap and ground should be changed to a VR75. (*Bib.1.*)

● TWO-TUBE PLUG-IN COIL EXCITER

In the two-tube exciter or low-power transmitter shown in the photographs of Figs. 1016, 1017 and 1019, a 6L6 oscillator is used to drive an 807 as an amplifier-doubler. As shown in the diagram of Fig. 1018, a Tri-tet circuit, which is used to obtain harmonic output, is reduced to the simple tetrode circuit for oscillator output at the crystal fundamental by short-circuiting the cathode tank circuit. Sufficient oscillator output at the fourth harmonic of the crystal frequency is obtainable to drive the 807, which may be operated as either a straight amplifier or frequency doubler, making it possible to obtain an output of 25 to 50 watts or more in four bands from a single crystal of properly-chosen frequency.

The exciter is constructed in a manner which conserves vertical panel space and which renders the coils and tubes readily accessible for change. The crystal socket is at the front so that frequencies within a band may be changed without the necessity for going to the rear.

The entire unit is designed to operate from a single 250-ma. supply delivering up to 750 volts (see Fig. 1110), the maximum voltage at which the 807 is designed to operate. A fixed bias of 45 volts is required for the 807 and the two heaters together consume 1.8 amperes at 6.3 volts. In the keying system shown, both the oscillator and amplifier are keyed simultaneously in the common cathode lead. If pre-

ferred, the fixed bias on the 807 may be increased to 90 volts and the oscillator circuit keyed alone, the grid leak being omitted in this case. A single milliammeter with a scale of 200 ma. may be switched to read the plate current of either stage.

Tuning

Since the 807 requires no neutralizing, tuning the exciter consists chiefly of selecting the proper coils and tuning the two plate circuits to resonance. Because it is possible to double or quadruple frequency in the plate circuit of the oscillator and to double frequency in the plate circuit of the 807 as well, there are several possible combinations of coils and crystals which will produce the same output frequency. However, much better efficiencies are obtainable when operating the 807 as a straight amplifier, rather than doubling, so that it is always advisable to operate the output stage in this manner whenever possible. This possibility occurs in all cases except where it is necessary to obtain output at the eighth harmonic of the crystal frequency — 14-Mc. output from a 1.75-Mc. crystal or 28-Mc. output from a 3.5-Mc. crystal. The accompanying chart will enable the operator to choose at a glance the combination required for the desired output from a given crystal. It also indicates the position in which SW_1 should be thrown. Always be sure that the crystal frequency chosen is one whose harmonics will fall in the band in which operation is to take place.

With the proper coils and crystal in place, SW_1 thrown to the correct position and both condensers set at minimum capacity (100 divisions on dial), the high-voltage should be applied with the meter switch in the second position where it will read plate current to the 807. If all resistances are correct and the plate voltage 750, the plate current should run ap-

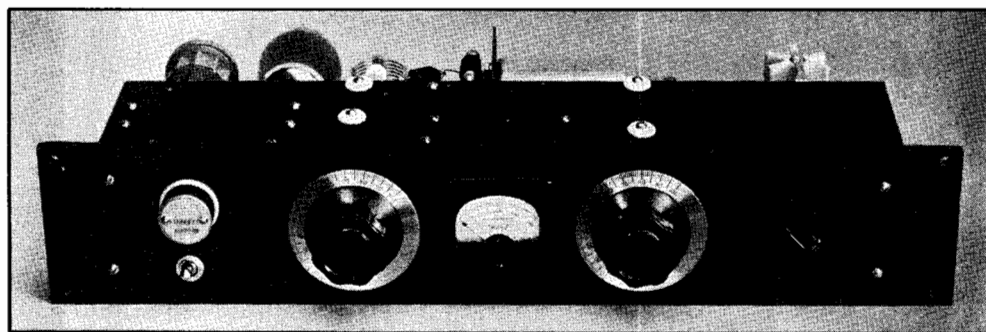

Fig. 1016 — The two-tube plug-in coil exciter is built to conserve space in the relay rack. The panel is $3\frac{1}{2}$ in. by 19 in. A clearance hole is cut in the left end of the panel for the crystal socket which is mounted in the chassis directly above the cathode-circuit switch. The left-hand dial controls the tuning of the oscillator plate

tank circuit, while the one to the right is the control for the output tank circuit. The switch at the right-hand end is for the 200-ma. meter. The outer ceramic buttons used in providing insulating mountings for the tank condensers are the only things appearing on top of the chassis.

The Radio Amateur's Handbook

COIL AND TUNING TABLE FOR TWO-TUBE PLUG-IN COIL EXCITER							
Xtal Band Mc.	Output Band Mc.	SW ₁	L ₁ Band Mc.	C ₁ L ₂ Band Mc.	C ₂ L ₃ Band Mc.	C ₁ *	C ₂ *
1.75	1.75	Closed	1.75	1.75	1.75	10	10
1.75	3.5	Open	1.75	3.5	3.5	10	30
3.5	3.5	Closed	3.5	3.5	3.5	10	30
1.75	7	Open	1.75	7	7	20	50
3.5	7	Open	3.5	7	7	20	50
7	7	Closed	7	7	7	20	50
1.75	14	Open	1.75	7	14	20	70
3.5	14	Open	3.5	14	14	35	70
7	14	Open	7	14	14	35	70
3.5	28	Open	3.5	14	28	35	80
7	28	Open	7	28	28	75	80

* Approx. settings for low-frequency ends of bands with dial reading zero at full capacity of condenser.

proximately 25 ma. Now close the key and turn the oscillator tank condenser to the approximate setting given in the accompanying table and watch for a rise in amplifier plate current. When this occurs, tune the oscillator for maximum amplifier plate current. Do not hold the key closed for long periods under this condition. As soon as the peak has been obtained, tune the amplifier plate tank condenser for resonance as indicated by a pronounced dip in plate current. Should the points of response on either condenser be found at points on the scale differing appreciably from those given in the table, each circuit should be checked with an absorption wavemeter to make sure that it is tuned to the correct frequency, since the ranges covered by some of the coils include odd harmonics which result in responses outside the amateur bands. Once checked, the dial settings can be logged for quick resetting to the desired frequency.

With the amplifier tuned, the meter switch may now be thrown to the first position, where the meter reads oscillator plate current, and the oscillator tank circuit tuned for minimum plate current consistent with satisfactory keying. Active crystals will usually oscillate continuously in the Tri-tet circuit, regardless of the setting of the tank condenser. When the tetrode circuit is in use, however, the circuit will oscillate only so long as the plate circuit is tuned within relatively narrow limits. SW₁ should never be left open when the oscillator plate circuit is tuned to the crystal frequency. The plate current to the oscillator will be found to vary widely in value, depending upon whether output is taken at the fundamental, second harmonic or fourth harmonic. At the specified plate voltage, it should run between 40 and 50 ma. at resonance with the plate circuit tuned to the crystal fundamental or second harmonic. When tuned to the fourth harmonic,

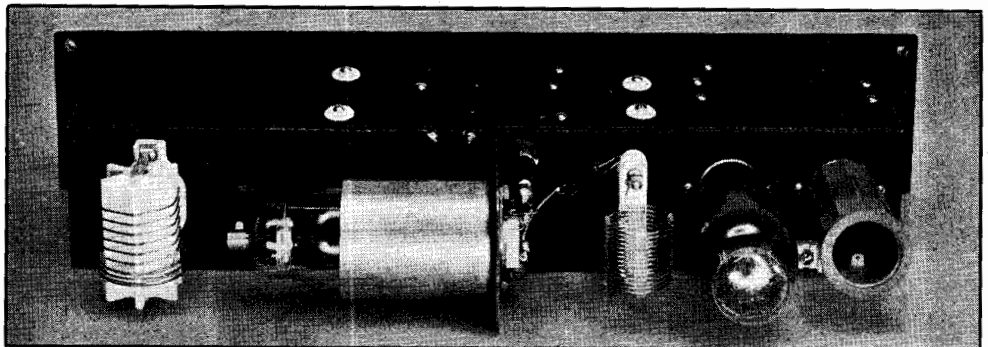

Fig. 1017 — The 4-prong socket for the cathode coil, the octal for the 6L6 oscillator and the 5-prong socket for the Coto coils used in the output tank circuit are sub-mounted in the rear edge of the chassis. The mounting for the National AR coils used in the oscillator plate circuit is fastened on short cone insulators, while the socket for the 807 is sub-mounted in the small steel partition. The grid r.f. choke and screen and cathode by-pass

condensers are fastened directly to the socket. Large clearance holes lined with grommets are provided for passing the connections through the chassis from the oscillator plate coil to the tank condenser and for the 807 plate lead. A pair of pin jacks serves as the link output terminals and power-supply connections are made to the Millen strip at the right end.

Transmitter Construction

the plate current will normally run between 85 and 95 ma.

Because the plate and screen of the 6L6 are operated from a voltage divider, their voltages will vary considerably with conditions of tuning. Plate voltage will vary between 400 and 450 except when operating at the fourth harmonic when it will normally fall to 340 volts or so. The screen voltage varies simultaneously from 280 to 210 volts or so.

The tank coils for the output circuit are fitted with link windings for coupling to a following stage with link input, to a low-impedance transmission line feeding an antenna or to an antenna coupler. In most cases, the maximum rated dissipation of 30 watts will not be exceeded in loading the output circuit until the 807 draws the maximum

rated plate current of 100 ma. However, when doubling frequency in the output stage, the plate current should be limited to 70 ma. at 28 Mc. and 80 ma. at 14 Mc. and to 90 ma. when operating the 807 as a straight amplifier at 28 Mc. Power output under these conditions should average 40 to 55 watts on all bands so long as the 807 is operated as a straight amplifier. When doubling frequency in the output circuit to 14 and 28 Mc., the output will normally be reduced to about 27 and 18 watts respectively.

Amplifier screen voltage will normally vary between 240 and 300 volts, the higher values obtaining when quadrupling in the oscillator.

If the exciter is operated from a power supply of lower voltage, the power output will, of course, be reduced in proportion. In such a

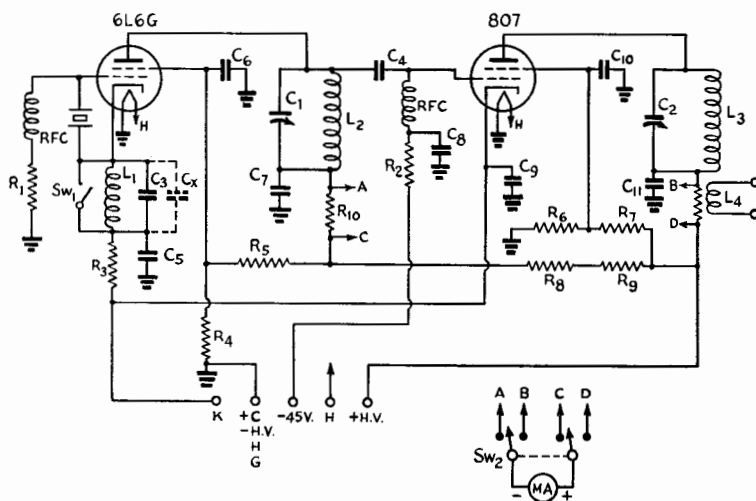

Fig. 1018 — Circuit diagram of the two-tube plug-in coil exciter.

- C₁ — 140- μ fd. midjet variable (Hammarlund MC-140M).
- C₂ — 150- μ fd. variable (Cardwell MR150BS).
- C₃ — 100- μ fd. mica.
- C₄ — 20- μ fd. mica.
- C₅, C₆, C₇, C₈, C₉, C₁₀ — 0.01- μ fd., 600-volt paper.
- C₁₁ — 0.01- μ fd., 1000-volt paper.
- C₁₂ — 100- μ fd. mica (see text).
- MA — Milliammeter, 0-200-ma. scale (Triplet Mod. 227A).
- R₁ — 20,000 ohms, 1-watt.
- R₂ — 25,000 ohms, 2-watt.
- R₃ — 200 ohms, 2-watt.
- R₄ — 10,000 ohms, 25-watt.
- R₅ — 3500 ohms, 25-watt.
- R₆, R₇ — 15,000 ohms, 25-watt.
- R₈, R₉ — 1250 ohms, 50-watt.
- R₁₀, R₁₁ — 10 ohms, 1-watt.
- R.f.c. — 2.5-mh. r.f. choke.
- SW₁ — S.p.s.t. toggle switch.
- SW₂ — D.p.d.t. rotary switch (Mallory 3222J).
- L₁ — 1.75-Mc. crystals — 32 turns No. 22 d.s.c., close-wound.
- 3.5-Mc. crystals — 10 turns No. 22 d.s.c., 1-in. long. Note: C_x connected in parallel with this coil; mounted in form.

- 7-Mc. crystals — 6 $\frac{1}{2}$ turns No. 22 d.s.c., $\frac{3}{4}$ -in. long.
- Above coils wound on Hammarlund $\frac{1}{2}$ -in. diam. 4-pin forms.
- L₂ — 1.75 Mc. — 56 turns, $\frac{1}{4}$ -in. diam., $\frac{1}{4}$ -in. long, 54 μ hs. (National AR80—no link).
- 3.5 Mc. — 28 turns, $\frac{1}{4}$ -in. diam., $\frac{1}{2}$ -in. long, 15 μ hs. (National AR40—no link).
- 7-Mc. — 14 turns, $\frac{1}{4}$ -in. diam., $\frac{1}{4}$ -in. long, 4.2 μ hs. (National AR20 — no link).
- 14 Mc. — 8 turns, $\frac{1}{4}$ -in. diam., $\frac{1}{2}$ -in. long, 1.25 μ hs. (National AR10 — no link).
- 28 Mc. — 4 turns, $\frac{1}{4}$ -in. diam., $\frac{3}{4}$ -in. long, 0.5 μ hy. (National AR10, 4 turns removed — no link).
- L₃ — 1.75 Mc. — 50 turns $\frac{1}{2}$ -in. diam., $2\frac{1}{8}$ -in. long, 52 μ hs. (Coto Coil CS6160E).
- 3.5 Mc. — 25 turns, $\frac{1}{2}$ -in. diam., $1\frac{5}{8}$ -in. long, 16 μ hs. (Coto Coil CS680E).
- 7 Mc. — 16 turns, $\frac{1}{2}$ -in. diam., $1\frac{7}{8}$ -in. long, 5.7 μ hs. (Coto Coil CS640E).
- 14 Mc. — 8 turns, $\frac{1}{2}$ -in. diam., $1\frac{5}{8}$ -in. long, 1.5 μ hs. (Coto Coil CS620E).
- 28 Mc. — 4 turns, $\frac{1}{2}$ -in. diam., $\frac{1}{2}$ -in. long, 0.7 μ hs. (Coto Coil CS610E).

The Radio Amateur's Handbook

Fig. 1019—Space inside the 4-in. by 17-in. by 3-in. chassis has been utilized to the greatest extent possible. R_8 and R_9 are to the right of the oscillator tank condenser, while R_4 , R_5 , R_6 and R_7 are mounted to the rear of the meter. The oscillator r.f. choke and grid leak are fastened to the crystal socket. Connections between the crystal socket and cathode switch are made directly and kept well-spaced. Meter-shunting resistances are fastened to the meter switch. Both tank-condenser shafts must be fitted with insulated couplings and panel bearings.

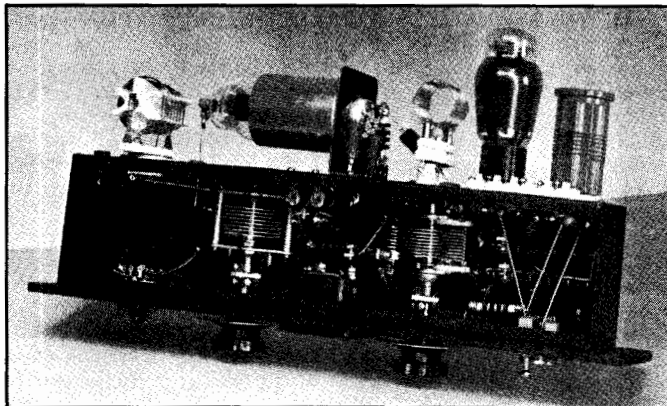

case, it may be of advantage to alter somewhat the values of resistance specified for the voltage dividers in order to increase the voltages on the oscillator plate and screen and also that of the screen of the 807. With a 600-volt supply, R_8 and R_9 should be changed to 1000 ohms each and R_4 to 20,000 ohms and R_5 to 10,000 ohms. Power output will average 30 to 35 watts with the 807 operating as a straight amplifier. (*Bib. 2.*)

● A BAND-SWITCHING EXCITER WITH 807 OUTPUT

The exciter or low-power transmitter pictured in Figs. 1020, 1021 and 1023 is designed for flexibility in being adaptable to all bands from 1.75 to 28 Mc., with crystals cut for different bands, and also for quick band changing over three bands. It consists of a 6C5 triode oscillator followed by two triode doubler stages in one tube, a 6N7; by means of a switch, the output of any of the three stages can be connected to the grid of the final tube, an 807 beam tetrode. A band-switching

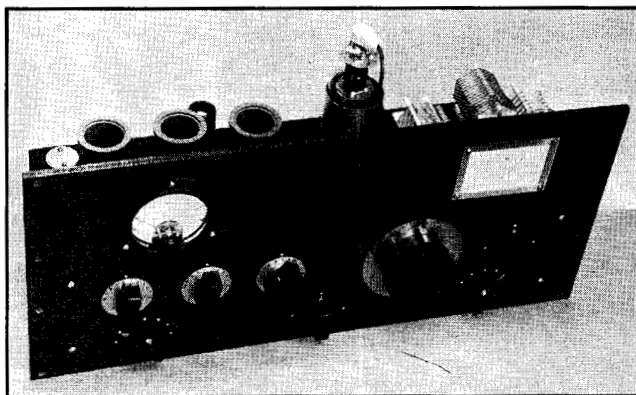

Fig. 1020—An 807 exciter or low-power transmitter combining the flexibility of plug-in coils with the convenience of band-switching. Crystal switching and meter switching also are provided.

plug-in coil assembly changes tank coils in the 807 plate circuit. The circuit diagram is given in Fig. 1022.

The oscillator, first and second doubler plate coils, L_1 , L_2 and L_3 respectively, need not be changed for crystals ground for a given band. The switching circuit is so arranged that the grids of unused stages are automatically disconnected from the preceding stage and grounded so that excitation is not applied to the idle tubes.

Capacity coupling between stages is used throughout. The plates of the first three stages are parallel-fed so that the plate tuning condensers can be mounted directly on the metal chassis. The 6C5, 6N7 and the 807 screen all operate from a 250-volt supply. Series feed is used in the 807 plate circuit, the tank condenser being of the type which is insulated from the chassis. Fixed bias of about 50 volts is used on the 807 grid.

Sockets are provided for seven crystals, with a switch to select the desired frequency. Plate currents for all tubes and screen current for the 807 are read by a 200-ma. meter which can be switched to any circuit by means of S_4 .

Keying is in the oscillator cathode circuit for break-in operation. Since in normal operation the crystal tank circuit, C_1L_1 , is tuned well on the high-frequency side of resonance, there is a tendency for the first doubler section to break into a tuned-grid tuned-plate type of oscillation when the key is up; this is prevented by a small amount of inductive neutralization provided by the single-turn coils L_5 and L_6 , wound as closely as possible to the ground end of each tank coil. The 28-Mc. coil does not need such a

Transmitter Construction

neutralizing winding since it is used only in the second doubler stage. L_5 and L_6 should be connected in such a way as to prevent self-oscillation of the first 6N7 section when the key is open; the proper connections can be determined by trial.

The above-chassis layout is shown in top-view photograph, Fig. 1021. Along the back, from left to right, are the spare crystal socket, the 6C5 and the 6N7. Directly in front of them are the sockets for the three low-level plate coils, L_1 , L_2 and L_3 . The sockets are mounted above the chassis on metal pillars. The three tuning condensers, C_1 , C_2 and C_3 , are mounted in front of their associated coils, and are fastened directly to the chassis. The "hot" leads from the coils come down through grommetted holes in the chassis, underneath the sockets; grounds to the coils are made direct to the chassis, on top.

In the amplifier section, the switch assembly is at the extreme right, with the 807 and tuning condenser, C_4 , just to its left. The switch assembly should be mounted far enough back

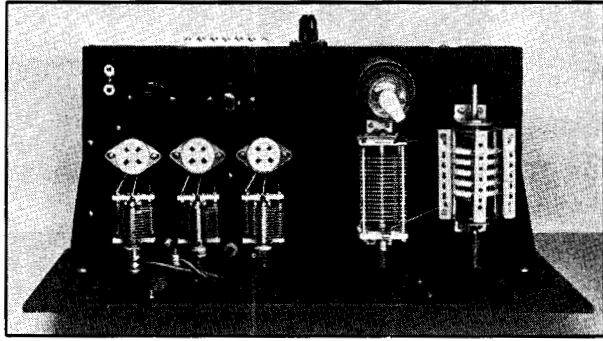

Fig. 1021 — Top view of the band-switching exciter, with coils removed. All tank circuit wiring is above the chassis. Insulated leads connect the first two sockets to complete the neutralizing circuit described in the text.

of the panel so that the coils will clear the sides of the relay rack or cabinet; this clearance will depend upon the type of rack used. It is desirable, of course, to keep the leads between C_4 and the switch as short as possible, considering the clearances which must be observed.

The chassis is 8 by 17 by 2 inches, the 2-inch depth being used so that the height of the unit will be within the 8 $\frac{3}{4}$ -inch relay-rack panel size.

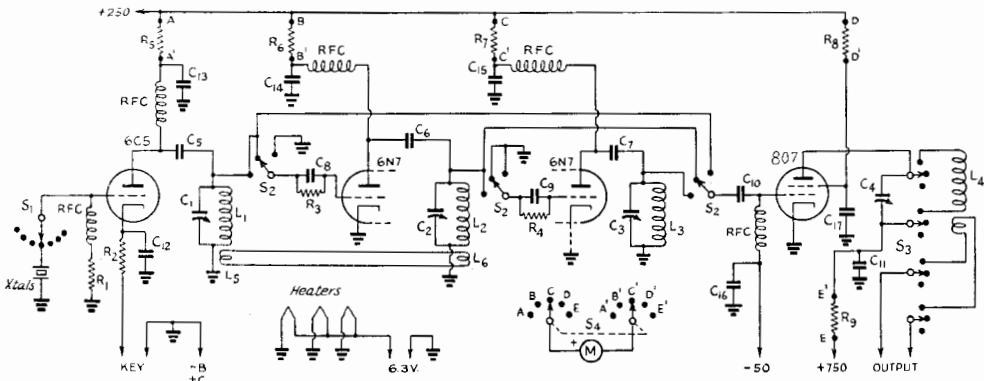

Fig. 1022 — Circuit diagram of the 807 band-switching exciter.

- C_1, C_2, C_3 — 100- μ fd. variable (National ST-100).
- C_4 — 150- μ fd. variable, 0.05" spacing (Hammarlund HFB-150-C).
- C_5, C_6, C_7 — 0.002- μ fd. mica, 500-volt.
- C_8, C_9, C_{10} — 100- μ fd. mica, 500-volt.
- C_{11} — 0.002- μ fd. mica, 2500-volt.
- $C_{12}-C_{17}$, inc. — 0.01- μ fd. paper, 600-volt.
- R_1 — 10,000 ohms, $\frac{1}{2}$ -watt.
- R_2 — 300 ohms, 1-watt.
- R_3, R_4 — 25,000 ohms, $\frac{1}{2}$ -watt.
- R_5-R_6 , inc. — 25 ohms, $\frac{1}{2}$ -watt.
- RFC — 2.5-mh. r.f. choke.
- S_1 — Ceramic wafer switch, 6 or more points.
- S_2 — Three-gang, three-position ceramic wafer switch (Yaxley 163C).
- S_3 — Band-switch with coil mountings (Coto type 700).
- S_4 — Two-gang, 6-position (5 used) ceramic wafer switch.
- M — 0-200 d.c. milliammeter, bakelite case.

- L_1, L_2, L_3 — 1.75 Mc.: 50 turns No. 22 d.s.c. close-wound. 3.5 Mc.: 26 turns No. 18; length 1 $\frac{1}{2}$ inches. 7 Mc.: 17 turns No. 18; length 1 $\frac{1}{2}$ inches. 14 Mc.: 8 turns No. 18; length 1 $\frac{1}{2}$ inches. 28 Mc.: 3 turns No. 18; length 1 in.
- All on $\frac{1}{2}$ -inch diameter forms (Hammarlund SWF-4); turns spaced evenly to fill specified winding length.
- L_4 — 1.75 Mc. — 50 turns, 1 $\frac{1}{2}$ -in. diam., 2 $\frac{3}{8}$ -in. long, 52 μ ys. (Coto Coil C16160E). 3.5 Mc. — 25 turns, 1 $\frac{1}{2}$ -in. diam., 1 $\frac{3}{8}$ -in. long, 16 μ ys. (Coto Coil C1630E). 7 Mc. — 16 turns, 1 $\frac{1}{2}$ -in. diam., 1 $\frac{7}{8}$ -in. long, 5.7 μ ys. (Coto Coil C1640E). 14 Mc. — 8 turns, 1 $\frac{1}{2}$ -in. diam., 1 $\frac{3}{8}$ -in. long, 1.5 μ ys. (Coto Coil C1620E). 28 Mc. — 4 turns, 1 $\frac{1}{2}$ -in. diam., 1 $\frac{1}{2}$ -in. long, 0.7 μ ys. (Coto Coil C1610E).
- L_5, L_6 — One turn at bottom of L_1 and L_2 . See text.

The Radio Amateur's Handbook

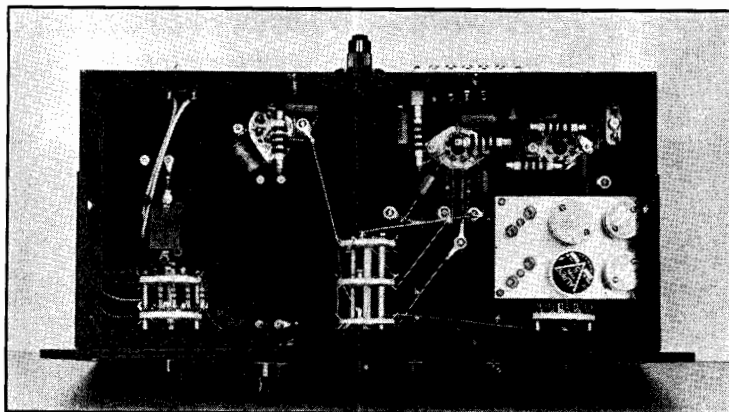

Fig. 1023 — Bottom view of the band-switching exciter, showing the multiple crystal mounting and switching circuits.

In the bottom view, Fig. 1023, the meter switch with its shunting resistors is at the left, with the 807 plate by-pass condenser, C_{11} , just above it. The stage switch, S_2 , is in the center. R.f. leads to this switch should be kept separated as much as the layout will permit. R.f. junction points are insulated by small ceramic pillars. In this view, the right-hand section of the 6N7 is the first doubler. The rotor contact of the section of S_2 nearest the panel goes to the grid of the first doubler, the middle section to the second doubler grid, and the third section to the 807 grid.

The multiple crystal mounting is a 3 by 4 $\frac{1}{2}$ -inch aluminum plate fitted with Amphenol crystal sockets, the assembly being mounted from the chassis by metal pillars. Six crystals may be mounted permanently here; the seventh socket is on top of the chassis for spare crystals or for bringing in excitation from an e.c.o. The crystal switch is in the lower right corner.

The 750-volt lead is brought in through a Millen safety terminal on the rear edge of the chassis. All other power connections come to a Millen five-terminal strip with barriers between terminals to prevent accidental contact.

All grounds are made directly to the chassis.

Tuning

To operate the exciter, coils for consecutively higher-frequency bands are plugged in at L_1 , L_2 and L_3 ; only five are necessary for operation with any crystals from 1.75 to 7 Mc. and for output from 1.75 to 28 Mc. For example, with 3.5-Mc. crystals, the 3.5-, 7- and 14-Mc. coils would be plugged in at L_1 , L_2 and L_3 respectively. For 1.75-Mc. crystals, the 1.75-, 3.5- and 7-Mc. coils would be used, and so on. The plate coils for the 807 circuit should cover the same three bands as the low-level coils.

Preliminary tuning should be done with the plate voltage for the 807 disconnected. Set S_2 so that all tubes are in use. Switch the milliammeter to the oscillator circuit and close the key. Rotate C_1 for the dip in plate current which indicates oscillation. The non-oscillating plate current should be between 20 and 25 ma., dropping to 15 or 20 when oscillating. Switch the meter to the doubler plate and adjust C_2 to minimum

plate current, or resonance. The off-resonance plate current should be about 30 ma. or more and the reading should be between 10 and 15 at resonance. Check the second doubler plate current and tuning similarly; the off-resonance plate current should again be around 30 ma., dropping to 15 or 20 at resonance. At this point the 807 screen current should be measured; with too much excitation it will be considerably higher than the rated value (about 12 ma.) and the excitation should not be kept on for more than a second or two.

Next, the plate voltage may be applied to the 807. The amplifier should not be operated without load for more than a few moments at a time, because under these conditions the screen dissipation is excessive. Use a 70-ohm dummy antenna or 60 watt lamp connected to the output link. The three bands may be checked in order by appropriate switching of S_2 and S_3 . With the 807 fully loaded, check the screen current to make sure it does not exceed 10 or 12 ma. If it is too high, reduce the excitation by detuning the crystal oscillator until it reaches the proper value. The 807 grid current may be measured with a lower-range milliammeter connected in series with the bias source, if desired. Maximum output will be secured with a grid current of about 3 or 4 milliamperes, a value which also will give about rated screen current. The screen current, in fact, is a very good indicator of excitation. The 807 should show no tendency to oscillate by itself when the key is open.

The current to each section of the 6N7 should be 20 ma. with the key open (no excitation). If the two currents are not the same or show changes with tuning of C_2 and C_1 with key open, the first doubler may be acting as a t.p.t.g. oscillator as previously mentioned, and the neutralizing circuit should be checked. Do not use more than 250 volts for the low-voltage

Transmitter Construction

Fig. 1024 — The 100-175-watt transmitter-exciter. Controls from left to right are for the oscillator, doubler and final amplifier. The chassis is 17 in. by 8 in. by 3 in. and the Presdwood panel 19 in. by 8¾ in. The controls are 1⅞ in. above the bottom of the panel and the two outer controls 2 in. in from the edges of the chassis or 3 in. from the panel edges. The crystal-oscillator tube and plate coil are to the left, the doubler plate coil to the left of the 6L6 doubler and the change-over plug-in form at the rear.

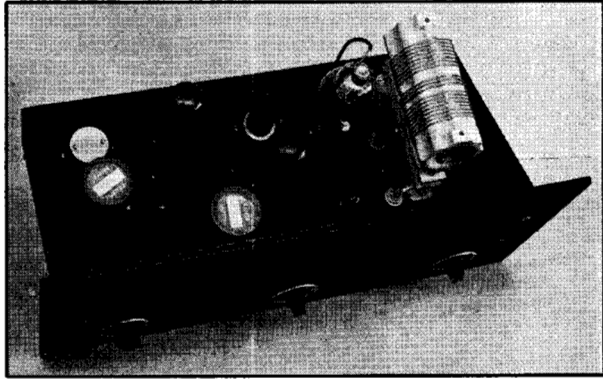

supply, as higher values will cause excessive 807 screen dissipation. Care also should be taken to avoid excessive excitation for the same reason. In normal operation, with C_1 detuned to reduce excitation to the proper value, the doubler plate currents will show little change between resonance and off-resonance tuning.

With maximum input to the 807 plate (75 watts) the output is approximately 50 watts on all bands except 28 Mc., where greater circuit losses decrease it to about 40 watts. The excitation is more than ample on all bands.

The low-voltage power supply should deliver 250 volts at approximately 75 ma., and the high-voltage supply 750 volts at 100 ma. (See Fig. 1110.) A 45-volt battery may be used to bias the 807.

● 100-TO-175-WATT TRANSMITTER OR EXCITER

The circuit of this unit is shown in Fig. 1026. The tube line-up consists of a 6L6 tetrode crystal oscillator, a 6L6 frequency doubler and a final amplifier which, in this case, employs a type HY51Z. The arrangement is suitable, however, for almost any triode-amplifier tube

operating at plate voltages between 750 and 1000 volts in which the plate connection is at the top of the tube and the grid terminal is in the base.

Output at either the crystal frequency or the second harmonic is readily obtainable. The complication of neutralizing the second stage when operating at the crystal frequency is eliminated by cutting this stage out of use. This is accomplished by means of a "dummy" plug-in form which serves as a low-loss switch. Capacities suitable for coupling the final-amplifier grid to the output of either the oscillator or the doubler are mounted inside the "dummy" plug-in forms and connected as shown in the insert in the circuit diagram.

Most of the constructional details will be evident from an inspection of the photographs of Figs. 1024 and 1025. The coils for the oscillator and frequency doubler are wound on Hammarlund 1½-inch diameter plug-in forms, while those for the final amplifier are wound on National XR-10A ceramic forms which plug into the XB-15 jack base mounted on the chassis. All tank condensers are mounted underneath the chassis. The final-amplifier tank condenser C_3 is mounted by means of angle

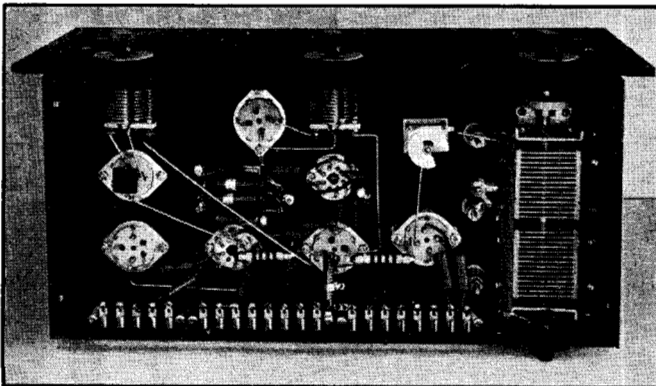

Fig. 1025 — Bottom view of 100-175-watt transmitter. The mica plate-circuit blocking condensers C_4 and C_5 are seen at the rear of the two small tank condensers. The resistors at the left-center are the two screen voltage dividers. The neutralizing condenser is in front of the HY51Z socket and the plate-circuit r.f. choke next to the tank condenser. C_6 is fastened to the front end plate of the tank condenser. The terminals are pin-jack type mounted on small angles behind the slot in the rear edge of the chassis. The positive high-voltage terminal is a special safety type. The final tank condenser is fitted with an insulated flexible shaft coupling and a bearing for the shaft extension is set in the panel.

The Radio Amateur's Handbook

brackets on four $\frac{5}{8}$ -inch cone insulators which bring the shaft $1\frac{1}{8}$ inches above the lower edge of the chassis and level with the shafts of the other two tank condensers which are shaft-hole mounted on the front edge of the chassis. The shaft of C_3 is fitted with an insulated flexible coupling and a bearing is set in the front edge of the chassis for the extension. Large clearance holes are cut in the panel for the shaft bushing of C_3 and the mounting nuts of the other two condensers. The dial plates are held in place by cementing them to the panel with Duco cement.

The socket of the final-amplifier tube is set about an inch below the surface of the chassis on long machine screws to bring the plate terminal down closer to the tank-coil terminal. A pair of fibre lug strips supports the voltage-divider resistances for oscillator and doubler screen voltages. Other resistances and chokes are self-supported.

Connections between the final tank coil and condenser are made through feed-through insulators set in the chassis. The neutralizing condenser, which may be seen in front of the final tube socket, is mounted on spacers. A

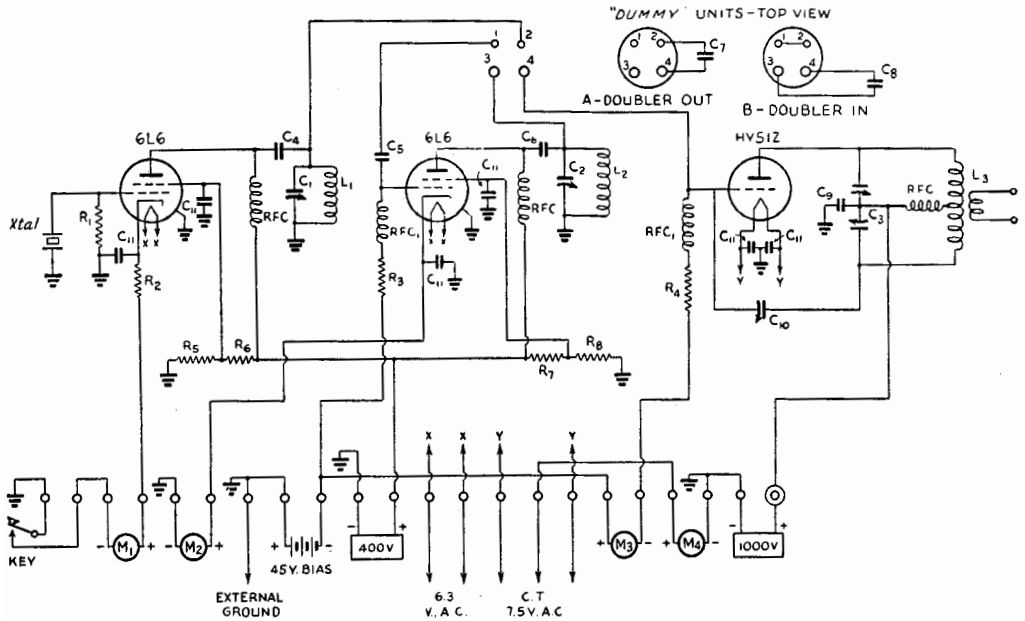

Fig. 1026 — Circuit diagram of 100- to 175-watt transmitter.

- C_1 — 100 μ fds. (National ST-100.)
- C_2 — 100 μ fds. (National ST-100.)
- C_3 — 180 μ fds. per section, 0.05-in. spacing (Cardwell MO-180-BD.)
- C_4 — 0.001 μ f. mica, 600 v.
- C_5 — 500 μ fds. mica, 600 v.
- C_6 — 0.001 μ f. mica, 600 v.
- C_7 — 50 μ fds. mica, 600 v.
- C_8 — 150 μ fds. mica, 600 v.
- C_9 — 0.002 μ f. mica, 5000 v., Cornell-Dubilier.
- C_{10} — Neutralizing condenser, 0.07-in. spacing, Cardwell Trim-Air, ZT-15-AS.
- C_{11} — 0.01 μ f. paper, 600 v.
- R_1 — 0.1 meg., 1-watt.
- R_2 — 400 ohms, 1-watt.
- R_3 — 0.1 meg., 1-watt.
- R_4 — 2500 ohms, 10-watt.
- R_5 — 50,000 ohms, 2-watt.
- R_6 — 10,000 ohms, 10-watt.
- R_7 — 6000 ohms, 10-watt.
- R_8 — 50,000 ohms, 2-watt.
- RFC₁ — National R-100 r.f. chokes, 2.5 mh.
- RFC₂ — National R154U r.f. choke, 1 mh.
- M_1 — Oscillator cathode milliammeter.
- M_2 — Doubler cathode milliammeter.
- M_3 — Final-amplifier grid milliammeter.
- M_4 — Final-amplifier cathode milliammeter.

- L_1 - L (Coils interchangeable).
- 1.75 Mc. — 60 turns No. 22 enam., $1\frac{1}{2}$ -in. diam., close wound.
- 3.5 Mc. — 30 turns No. 22 enam., $1\frac{1}{2}$ -in. diam., $1\frac{1}{2}$ -in. long.
- 7 Mc. — 15 turns No. 22 enam., $1\frac{1}{2}$ -in. diam., $1\frac{1}{4}$ -in. long.
- 14 Mc. — 8 turns No. 16 enam., $1\frac{1}{2}$ -in. diam., $1\frac{1}{4}$ -in. long.
- 28 Mc. — 3 turns No. 12 wire, $1\frac{1}{2}$ -in. diam., self-supporting mounted on small banana-type plugs. Adjust spacing to tune to resonance near minimum of C_2 .
- L_3 -1.75 Mc. — 40 turns No. 18, $2\frac{1}{2}$ -in. diameter wound on bakelite tubing form to fit mounting.
- 3.5 Mc. — 30 turns No. 14, $2\frac{1}{2}$ -in. diam., $3\frac{1}{2}$ -in. long wound on form to fit mounting.
- 7 Mc. — 16 turns No. 14 bare, $2\frac{1}{2}$ -in. diam., 3-in. long with 1-in. space at center (National XR-10A form, start each half of winding one hole from end).
- 14 Mc. — 12 turns No. 14 bare, $2\frac{1}{2}$ -in. diam., $3\frac{1}{2}$ -in. long (National XR-10A form, turns wound in alternate grooves).
- 28 Mc. — 6 turns No. 14 bare, $2\frac{1}{2}$ -in. diam., $3\frac{1}{2}$ -in. long (National XR-10A form, turns wound every 4th turn).

Transmitter Construction

clearance hole in the chassis permits the shaft to protrude a half-inch or so above the chassis so that it may be adjusted with a screwdriver.

All terminals for external connections, excepting that for the positive 1000-volt connection, are of the pin-jack type. The strips are mounted on small angle pieces behind a slot cut in the rear edge of the chassis. Insulated pin jacks are used to make connections and leave no exposed metal contacts. Separate connections are provided for meter and key connections as shown in the diagram.

When working at the crystal frequency, the "dummy" unit with connections shown in the detail of Fig. 1026 at A should be plugged in; if operating at twice the crystal frequency, the other "dummy" unit will be used.

Two plate supplies are required, one delivering 400 volts, 150 ma. for the 6L6's and the other for the final amplifier. The HY51Z requires 1000 volts, 175 ma. at maximum rated input. A 45-volt battery should be provided for fixed bias for the doubler and final amplifier. When the oscillator is driving the final amplifier, the cathode current should dip to about 50 ma. at resonance; when driving the doubler, it should run in the neighborhood of 30 ma. The doubler cathode current normally runs between 65 and 100 ma. at resonance when driving the final, the higher currents occurring at the higher frequencies.

Grid current to the final amplifier (HY51Z) should run between 30 and 40 ma. on all bands except when operating at 28 Mc. with a 14-Mc. crystal when the grid current may fall to 25 ma. with the amplifier loaded. These values should indicate sufficient excitation. The amplifier may be loaded until the cathode current reaches 200 to 225 ma. at resonance. The difference between cathode and grid currents should not exceed 175 ma. Operating conditions for other tubes may be taken from the tube tables of Chapter 20.

The output circuit is designed for link coupling to an antenna tuner. Where the space is available, the link may be wound between the turns of the tank-coil winding; otherwise, it may be wound self-supporting and placed inside the coil form. The number of link turns for proper loading will depend upon the antenna system and must be determined experimentally.

● COMPACT 250-WATT TRANSMITTER

The photographs of Figs. 1027, 1028 and 1030 show various views of a multi-band transmitter capable of handling 250 watts. Output may be obtained at the second and fourth har-

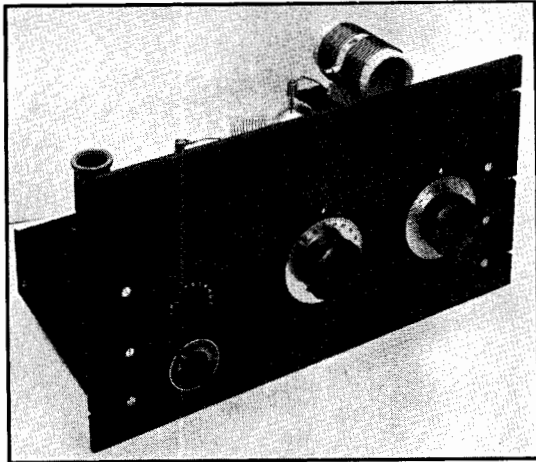

Fig. 1027 — Front panel view of the compact 250-watt transmitter showing position of controls. The oscillator plate tuning control is below the crystal switch in the lower left-hand corner. The Presdwood panel is $10\frac{1}{2}$ in. high and of standard 19-in. rack width.

monic frequencies as well as the fundamental frequency of the crystal. Referring to the circuit diagram of Fig. 1029, a 6V6 Tri-tet oscillator operating with 300 volts on the plate and 150 on the screen furnishes adequate excitation for the 807 buffer-doubler. The final amplifier makes use of a 75T in this instance, although the layout is satisfactory for other tubes of similar rating and terminal arrangement. Parallel feed is used in the oscillator circuit to permit grounding the tank condenser.

Instead of the usual air variable condenser for the cathode tank condenser C_1 , a mica trimmer-type condenser is mounted in each of the plug-in cathode coils L_1 and thus this tuning control is eliminated. To obtain a satisfactory impedance match between the plate circuit of the 807 and the high-impedance grid circuit of the 75T, it is necessary to tap the plate of the 807 down on the tank coil. Should another type be used in the final amplifier, a different coupling adjustment may be required for maximum excitation. An amplifier with a low-impedance grid may require tapping the amplifier grid down on the driver tank coil instead of the driver plate. Since a high-voltage connection is made to the rotors of the split-stator condenser, a well insulated shaft coupling is required.

Screen voltage for the doubler is obtained from a separate voltage divider to reduce fluctuations in oscillator plate voltage with tuning of the 807. In this stage, as well as in the oscillator plate circuit, the tank condenser specified has a sufficient capacity range to permit covering two adjacent bands without coil changing. This is a thoroughly practical and

The Radio Amateur's Handbook

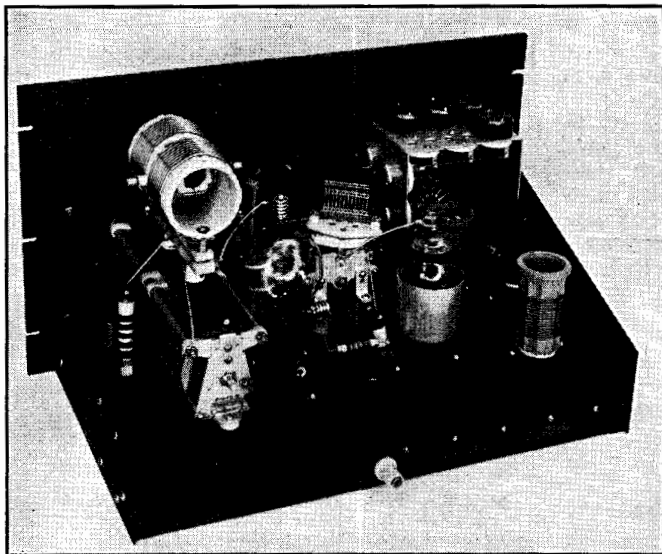

Fig. 1028 — The final plate tank condenser of the 250-watt transmitter is insulated from the chassis by button-type feed-through insulators at front and rear. It should be placed as far to the rear of the chassis as possible with its shaft on a line 3 in. from the edge of the chassis. The tank-coil strip is supported by small stand-off insulators on a strip of Presdwood fastened to the condenser frame. The neutralizing condenser is in front of the 75T. The mica condenser C_6 is fastened to the tank-condenser end plate and the coupling condenser C_7 is supported by a small stand-off at the rear of the buffer tank condenser. The latter is mounted on $\frac{5}{8}$ -in. cone insulators with spacers and brackets to bring the shaft up level with that of the final tank condenser. The buffer coil socket is mounted on top of the condenser. The crystal switch is mounted on the panel at the center of the socket assembly.

convenient method of band-changing between 1.75 and 3.5 and between 3.5 and 7 Mc. The L/C ratio becomes so low in covering 7 to 14 Mc. and 14 to 28 Mc., however, that high circulating tank currents cause excessive coil heating, except at very low power, unless unusually heavy coils are used. In this instance, separate coils for 14 and 28 Mc. are recommended for the buffer-doubler stage.

The condenser spacing specified for C_4 is conservatively adequate for 100 per cent modulation at 1500 volts. The condenser provides adequate capacity for all bands including the 1.75-Mc. band. (If the Johnson coil designed for this band is used, a single-section fixed air padding condenser connected directly across the tank coil will be required. This padder should have an air gap of 0.125 inch and a capacity of 80 $\mu\text{fd.}$; the Cardwell type JD80-OS or a similar condenser should be satisfactory.) For a lowest frequency of 7 Mc., a tank condenser of 100 $\mu\text{fd.}$ per section with the spacing specified could be used. (Johnson 100ED30.)

Series plate feed was found to be essential in the final amplifier because no available r.f. choke was found adequate at 28 Mc. If operation is to be confined to a highest frequency of 14 Mc., there is no reason why parallel plate feed may not be used and the tank condenser mounted directly upon the chassis.

Keying and Metering

The diagrams of Fig. 1031 show the terminal arrangement and connections for either oscillator or buffer-doubler keying. The latter is recommended whenever break-in operation is

not required. Keying of the buffer-doubler eliminates the necessity for a source of fixed bias for the 807 and invariably results in superior keying characteristics.

It will be noticed that the plate meters are placed in the negative return leads for the purpose of reducing danger. These meters, of course, read total space current which includes grid and screen currents as well as plate current. The former are low enough to be of little consequence in all but the final stage. Here the grid current should be subtracted from the plate-meter reading to obtain the true plate current.

As mentioned previously, each of the cathode tank-coil forms is fitted with an adjustable mica padder. The type of condenser specified is a dual-range affair. For our purpose, the two sections should be connected together. This is done by connecting the two adjacent terminal tabs together. Since it would be difficult to pass both wires for the ends of the coil and connecting wires for the condenser through the same pins in the coil form, a separate pair of pins is used for each purpose and the appropriate socket prongs connected together so that the condenser is connected across the coil when it is plugged into its socket. In mounting the condenser in the coil form, a piece of fairly stiff wire (the No. 22 with which the coils are wound will do) about 6 inches long should be soldered to each condenser terminal and the leads pulled out straight and the insulation scraped off from all but the last 2 inches or so nearest the condenser. The leads may then be fished down through the appropriate pins in the form, pulled tight and soldered fast.

Transmitter Construction

Crystal Mounting

The crystal mounting is made from a strip of $\frac{1}{8}$ -inch aluminum 3 inches wide and 15 inches long. Starting at one end of the strip, lines are marked across the strip at $\frac{1}{2}$ inch, $1\frac{1}{16}$ inches, $2\frac{3}{4}$ inches, $4\frac{3}{16}$ inches, $5\frac{1}{4}$ inches, $6\frac{1}{16}$ inches, $7\frac{1}{2}$ inches, $8\frac{3}{16}$ inches, $9\frac{3}{4}$ inches and $14\frac{1}{2}$ inches from the end. Longitudinal lines are then drawn the length of the strip $\frac{1}{4}$ inch, $2\frac{3}{8}$

inch and $1\frac{3}{16}$ inches from each edge. This will serve to mark the centers of all required mounting and clearance holes for the Hammarlund crystal sockets. The mounting screws take a No. 33 hole and the clearance holes are $\frac{5}{16}$ -inch diameter. After the holes have been drilled, the strip is bent at the $\frac{1}{2}$ -inch, $5\frac{1}{4}$ -inch, $9\frac{3}{4}$ -inch and $14\frac{1}{2}$ -inch lines which are scratched deeply to assist in the bending.

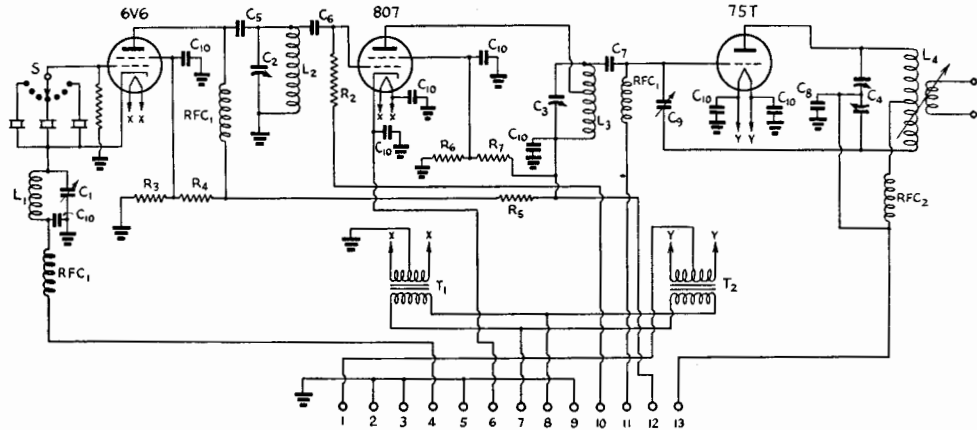

Fig. 1029 — Circuit diagram of the 250-watt transmitter.

- | | |
|---|---|
| <p>C₁ — 260 μfds. max. mica trimmer-type cathode tuning condenser (mounted in coil form, see text) (Hammarlund CTS-160).</p> <p>C₂ — 250 μfds. max. midget variable (Hammarlund MC-250M).</p> <p>C₃ — 260 μfds. max. plate spacing 0.03 in. (Cardwell MR260-BS).</p> <p>C₄ — 200 μfds. max. per section,</p> <p>RFC₁ — Receiving-type r.f. choke, 2.5 mh. (National or Hammarlund).</p> <p>RFC₂ — Transmitting-type r.f. choke (National R-154U).</p> <p>S — 11-point tap switch (Mallory type 1311L).</p> <p>T₁ — Filament transformer, 6.3 v., 2 a. (Thordarson type T19F81).</p> <p>T₂ — Filament transformer, 5 v., 8 a. (Thordarson type T19F84).</p> <p>L₁ — 1.75-Mc. crystal — 30 turns No. 22 enam., $1\frac{1}{2}$ in. diam., turns close-wound.</p> <p>3.5-Mc. crystal — 10 turns No. 22 enam., $1\frac{1}{2}$ in. diam., 1 in. long.</p> <p>7-Mc. crystal — 7 turns No. 22 enam., $1\frac{1}{2}$ in. diam., 1 in. long.</p> <p>L₂ — 1.75 to 3.5 Mc. — 30 turns No. 22 enam., $1\frac{1}{2}$ in. diam., 1 in. long.</p> <p>3.5 to 7 Mc. — 18 turns No. 22 enam., $1\frac{1}{2}$ in. diam., $1\frac{1}{2}$ in. long.</p> <p>7 to 14 Mc. — 8 turns No. 22 enam., $1\frac{1}{2}$ in. diam., $1\frac{1}{4}$ in. long.</p> <p>L₃ — 1.75 to 3.5 Mc. — Barker & Williamson type M-80 with 15 turns removed, tapped at 10th turn from the plate end. Inductance — 27 μh. Coil same as L₂ may be substituted. Tap at approximately 8th turn from plate end.</p> <p>3.5 to 7 Mc. — B&W type M-40 with 8 turns removed, tapped at 5th turn from plate end. Inductance — 8 μh. Coil same as L₂, tapped</p> | <p>plate spacing 0.075 in. (Johnson 200ED30) (see text suggestions for higher frequency-bands).</p> <p>C₅ — 0.001-μfd. mica, 500 volts.</p> <p>C₆ — 0.0001-μfd. mica, 500 volts.</p> <p>C₇ — 0.0001-μfd. mica, 2500 volts (Aerovox).</p> <p>C₈ — 0.001-μfd. mica, 5000 volts (Aerovox).</p> <p>C₉ — Neutralizing condenser (National NC800).</p> <p>C₁₀ — 0.01-μfd. paper, 600 volts.</p> <p>R₁ — 0.1-meg., 1-watt, non-inductive (not marked).</p> <p>R₂ — 50,000 ohms, 1-watt, non-inductive (see text).</p> <p>R₃ — 10,000 ohms, 2-watt.</p> <p>R₄ — 10,000 ohms, 10-watt.</p> <p>R₅ — 10,000 ohms, 25-watt.</p> <p>R₆ — 30,000 ohms, 10-watt.</p> <p>R₇ — 15,000 ohms, 10-watt.</p> |
|---|---|
- at 6th turn from plate end may be substituted.
- 14 Mc. — B&W type M-20, tapped at 3rd turn from plate end. Inductance — 2.8 μ h. Coil of 10 turns, $1\frac{1}{2}$ in. diam., $1\frac{1}{2}$ in. long, tapped at 3rd turn from plate end may be substituted.
- 28 Mc. — B&W type M-10, 1 turn removed, tapped 1 turn from plate end. Inductance — 0.6 μ h. Coil of 4 turns, $1\frac{1}{2}$ in. diam., $1\frac{1}{2}$ in. long, tapped at 1 turn from plate end may be substituted.
- L₄ — 1.75 Mc. — Johnson type 684 coil. (NOTE: This coil requires additional padder condenser as mentioned in text.) Coil of 50 turns No. 18 d.c.c., $2\frac{1}{2}$ in. diam., 4 in. long including $\frac{3}{8}$ -in. space at center may be substituted, and will not require padder.
- 3.5 Mc. — Johnson type 663 coil. Coil of 34 turns No. 16, $2\frac{1}{2}$ in. diam., 4 in. long including $\frac{1}{2}$ -in. space at center may be substituted.
- 7 Mc. — Johnson type 662 coil. Coil of 20 turns No. 12, $2\frac{1}{2}$ in. diam., 4 in. long including $\frac{1}{2}$ -in. space at center may be substituted.
- 14 Mc. — Johnson type 661 coil. Coil of 10 turns No. 12, $2\frac{1}{2}$ in. diam., 3 in. long including $\frac{1}{2}$ -in. space at the center may be substituted.
- 28 Mc. — Johnson type 660 coil. Coil of 6 turns No. 12, $2\frac{1}{4}$ in. diam., $3\frac{1}{2}$ in. long including $\frac{1}{2}$ -in. space at the center may be substituted.
- NOTE: Spaces above are for link windings.

The Radio Amateur's Handbook

The 11-point crystal switch is wired to the sockets before mounting in the panel in a hole 4 inches from the left edge of the panel and $4\frac{1}{2}$ inches up from the bottom edge to balance the shaft of the tank condenser of the final amplifier.

Biasing Requirements

The 807 requires 90 volts of fixed bias if the oscillator is to be keyed for break-in operation and the 75T requires approximately 150 volts for plate-current cut-off with excitation removed and 300 volts under recommended operating conditions. If batteries are used, the biasing is simply a matter of connecting a 4000-ohm leak in series with the negative-terminal connection of 150 volts of battery to the grid return circuit of the 75T and tapping the 807 grid return on at 90 volts. However, a bias pack will be more practical in most instances. The pack should preferably be one delivering any voltage from 175 to 300 volts. If the voltage does not exceed 300 volts, nothing more than a 10,000-ohm bleeder will be re-

quired to make it satisfactory. An r.f. choke should replace R_2 and the return connected to a point about $\frac{2}{3}$ of the way up on the bleeder from the positive end. The lower end of the choke should be by-passed to the chassis with a 0.01- μ fd. condenser.

If the voltage of the pack exceeds 300 volts, the bleeder should have a resistance of about 3000 ohms per 100 volts and should be provided with three sliders for adjusting the biasing voltages under operation. One slider should short-circuit a portion of the negative end of the resistor while the other two provide bias taps for the 807 and final. For initial trial, tap the return of the final amplifier at about 6000 ohms and the 807 at about 3500 ohms from the positive end with the third slider set at the extreme negative end.

If the buffer-doubler is to be keyed, the grid leak R_2 is connected through the meter to ground and no fixed bias is required for this stage.

Tuning

From the accompanying coil table, it will be seen that a separate cathode tank is required for crystals of each frequency band from 1.75 to 7 Mc. Each oscillator plate tank coil is designed to cover two adjacent bands for convenience in changing bands. Only two coils, the first and last, need be wound if frequent change between 3.5 and 7 Mc. is not required. Likewise, in the buffer-doubler stage, each of the two lowest-frequency coils covers two bands. All of these are required, however, if all bands are to be covered. A separate coil for each band is required for the final amplifier.

Several coil and tuning combinations are possible for most output frequencies. The oscillator will double frequency as well as the doubler itself, so that it is possible to go to 7-Mc. output from a 1.75-Mc. crystal, 14 Mc. from a 3.5-Mc. crystal or to 28 Mc. from a 7-Mc. crystal. The table shows various com-

EXCITER TUNING TABLE

Xtal Freq.	Output Freq.	L ₁	L ₂	L ₃	C ₄	C ₃
* 1.75	1.75	1.75	1.75-3.5	1.75-3.5	high	high
1.75	3.5	1.75	1.75-3.5	1.75-3.5	high	low
* 1.75	3.5	1.75	1.75-3.5	1.75-3.5	low	low
* 1.75	7	1.75	1.75-3.5	3.5-7	low	low
* 3.5	3.5	3.5	1.75-3.5	1.75-3.5	low	low
3.5	3.5	3.5	3.5-7	1.75-3.5	high	low
3.5	3.5	3.5	3.5-7	3.5-7	high	high
3.5	7	3.5	3.5-7	3.5-7	high	low
* 3.5	7	3.5	3.5-7	3.5-7	low	low
3.5	7	3.5	7-14	3.5-7	high	low
* 3.5	14	3.5	3.5-7	14	low	low
3.5	14	3.5	7-14	14	high	low
7	7	7	3.5-7	3.5-7	high	low
* 7	7	7	3.5-7	3.5-7	low	low
7	7	7	7-14	3.5-7	high	low
7	14	7	3.5-7	14	low	low
* 7	14	7	7-14	14	high	low
7	14	7	7-14	14	low	low
* 7	28	7	7-14	28	low	low

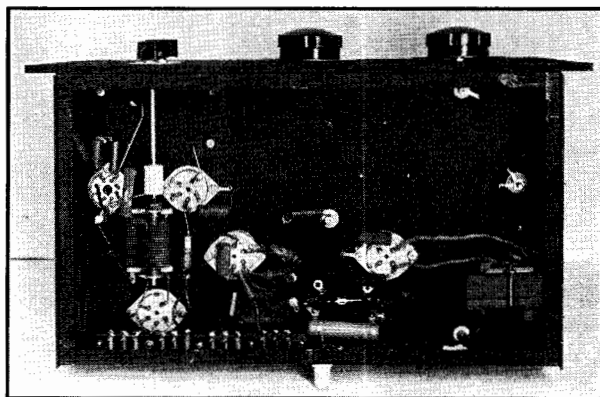

Fig. 1030 — The oscillator plate tank circuit of the 250-watt transmitter is mounted in the space at the center of the three sockets. The 6L6 and cathode-coil sockets are toward the front. The sockets for the 807 and 75T are dropped an inch or so below the top of the chassis in long screws with spacers. The 6.3-volt filament transformer is mounted near the 807 socket and the 5-volt transformer at the right. The pin-jack type terminal strip is mounted on small angles behind a long slot cut in the rear edge of the chassis. The jack-top feed-through is the positive 1500-volt terminal. It should be protected with a rubber-tubing sleeve after connection has been made. The chassis is 10 in. by 17 in. by 3 in.

Transmitter Construction

binations which may be used. Certain combinations should be selected (such as those marked with an asterisk) until the operator is thoroughly familiar with the transmitter. Later, it will be a simple matter to swing the exciter from one band to another with the most appropriate coils in place.

With a set of suitable coils plugged in, C_2 and C_3 should be turned near minimum or maximum capacity, depending upon the frequency desired in these circuits. Make certain that the crystal switch is turned to connect in the desired crystal and turn the adjusting screw of the cathode-circuit condenser as far as possible in a clockwise direction. The filament supply, the bias pack and the 600-volt plate supply may now be turned on in that order. If the key is in the oscillator circuit (recommended for initial test), none of the meters should indicate current flow with the key open. With the key closed, the oscillator plate current should be 20 to 30 ma. if the circuit is not oscillating, dropping to about 15 ma. when oscillating. Adjusting the oscillator plate tank condenser should cause a slight dip in oscillator plate current and a high swing in plate current to the 807 at some point. If this is not obtained at any setting of C_3 , the oscillator plate current will probably be running high. With the key closed, the adjusting screw of the cathode condenser should be turned slowly counterclockwise until the oscillator plate current takes a sudden drop. Tuning the plate condenser should then develop two points where plate current will flow to the 807, one near maximum capacity of C_2 and one near minimum capacity. If only the former is found, a turn or so should be removed until both are found. If, on the other hand, only the one near minimum is found, a turn or two should be added. The key should be closed only for short intervals until the tank circuit of the 807, L_3C_3 , is tuned to resonance as indicated by a dip in plate current.

Adjusting the Cathode Tank

Now tune the plate circuit of the oscillator to the second harmonic of the crystal frequency, making sure that a coil tuning to this harmonic frequency or double this harmonic frequency is in the plate circuit of the 807. (In the case of 3.5-Mc. crystals, either coil covering 7 Mc. will do.) Tune the plate circuit for maximum 807 grid current and then adjust the cathode condenser also for maximum grid current. Any grid current value between 2 and 5 ma. should be satisfactory.

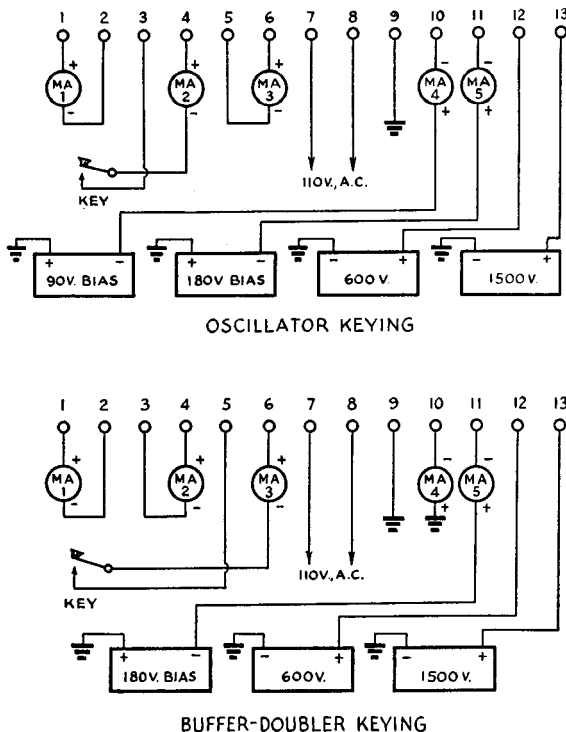

Fig. 1031 — Terminal and meter connections for the 250-watt transmitter, for oscillator keying or for buffer-doubler keying.

With the oscillator cathode circuit tuned correctly, the off-resonance plate current of the 807 will run between 125 and 150 ma., dropping to 60 to 100 ma. at resonance, depending upon frequency. If the oscillator plate circuit is tuned to the crystal fundamental, it should not be tuned too close to resonance to permit ready starting and stopping of crystal oscillation. Tuning the 807 plate circuit to resonance should cause grid-current flow to the final amplifier. This current should run between 35 and 50 ma., depending upon frequency.

The final amplifier is neutralized and tuned as described in Chapter 14. With a 1500-volt plate supply, no difficulty should be experienced in lighting the 150-watt lamp dummy load to more than normal brilliancy on all bands.

Checking Voltages and Currents

With the final amplifier running with the lamp dummy load, various voltages and currents should be checked. The voltage of the plate supply for the exciter should be as close to 600 as possible. The voltage dividers recommended will then provide voltages close to the following values: oscillator plate, 300 v.; oscillator screen, 150 v.; 807 screen, 300 v.

A check should be made on the biasing volt-

The Radio Amateur's Handbook

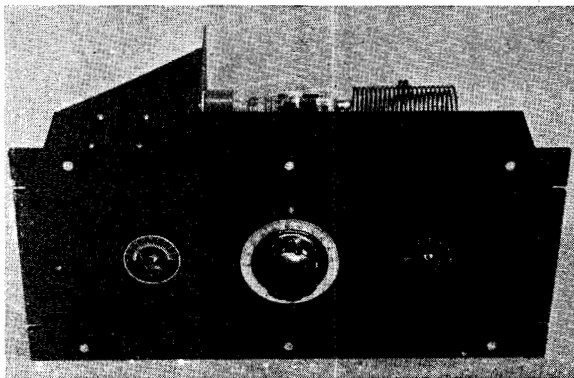

Fig. 1032 — A 450-watt push-pull amplifier of dish-type construction suitable for 812's, T55's, 35T's, 808's, RK51's, HY51's, HK154's or other tubes of similar style operating at plate voltages of 1000 to 1500. The meter switch is at the right, the control for the plate tank condenser at the center and the grid-circuit control at the left. The panel which is $8\frac{3}{4}$ by 19 in. is fitted with panel bearings for the condenser-shaft extensions. It is fastened to the chassis by flat-head screws after the bottom edges of the chassis have been drilled and tapped.

age for the 75T together with its grid current while operating under full load. The biasing voltage should be not less than 300 with a grid current of not less than 25 ma. If the voltage is 300 or higher but the grid current less than 25 ma., the slider on the bias-pack voltage divider should be moved slightly towards the positive end of the resistor until grid current is up to normal. Under operation, grid voltage for the 807 should be 200 to 250. Grid current at this voltage should run 2 to 5 ma. Corrections may be made by adjustment of the slider on the biasing resistor. If it is now found that the biasing voltage with the key open is insufficient to cut off plate current, the slider at the negative end of the biasing resistor should be advanced until plate current is cut off. Biasing should again be checked under operating conditions and readjustments made if required. It is preferable that these biasing adjustments be made at the highest frequency to be used.

Final-amplifier grid current at the lower frequencies may then be held to a maximum of 30 ma. by tuning of the oscillator plate tank circuit. In cases where the 807 is keyed and grid-leak bias only is used, any grid current between 3 and 8 ma. should give satisfactory performance.

In the tests which were run at 28 Mc., the manufactured coil developed considerable heat when allowed to operate continuously for appreciable periods. This is, of course, rather to be expected with coils wound on solid forms when operated at the higher frequencies. Although less convenient, those who wish highest efficiency will probably prefer a self-supporting coil.

In coupling to the antenna, the best method will depend upon the type of antenna system to be used. The coupling coil of the Johnson tank coil is suitable for coupling directly into any untuned line of impedance up to 600 ohms. When

Fig. 1033 — The plate tank-coil jack strip of the 450-watt push-pull amplifier is fastened to the tank-condenser frame with strip-metal brackets. The assembly, mounted on $\frac{3}{8}$ -in. stand-off insulators is placed at the center of the chassis as far to the left as possible. The condenser shaft is extended at right angles through the bearing in the center of the chassis by means of two Millen 45-degree shaft joints connected together by a short length of bakelite shafting. The sockets for the 812's are sub-mounted on the 6-by-8-in. partition $3\frac{1}{2}$ inches up from the chassis and $1\frac{1}{8}$ inches from each edge and are orientated so that the plates of the tubes will be in a vertical plane when in use.

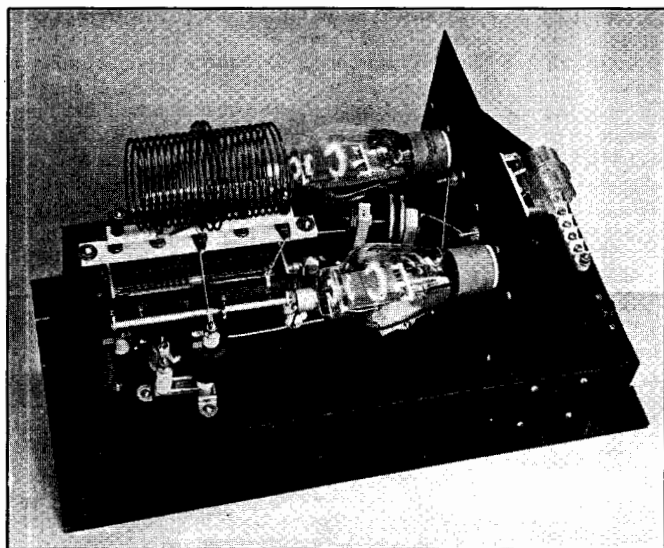

Transmitter Construction

Fig. 1034 — Wiring diagram of the 450-watt push-pull amplifier.

- C₁** — 100 μ fds. per section (Hammarlund MCD-100M).
C₂ — 100 μ fds. per section (Cardwell MT100G), 0.07-in. spacing.
C₃ — 500 μ fds. mica, 600-volt.
C₄ — Neutralizing condenser (Hammarlund N10).
C₅ — 0.01- μ fd. paper, 600-volt.
C₆ — 0.002- μ fd. mica, 5000-volt.
R, R₁ — Grid leak, 6000 ohms, 10 watts.
R₂ — Grid-current meter shunt, 25 to 50 ohms, 2-watt.
R₃ — Same as R₂.
R₄ — Cathode-current meter shunt. See text.
R₅ — Same as R₄.
L₁ — National AR series coils with center link (variable-link type recommended).

Substitute coils may be wound on 1½-in. diameter forms as follows:

- 3.5 Mc.** — 44 turns, 2 in. long.
7 Mc. — 22 turns, 2 in. long.
14 Mc. — 10 turns, 1½ in. long.
28 Mc. — 6 turns, 1½ in. long.
L₂ — Barker and Williamson TL series with center links.
 Substitute coils may be wound as follows:
3.5 Mc. — 36 turns, 2½-in. diam., 4 in. long.
7 Mc. — 18 turns, 2½-in. diam., 4 in. long.
14 Mc. — 10 turns, 2½-in. diam., 3 in. long.
28 Mc. — 6 turns, 2½-in. diam., 3 in. long.
SW — Mallory 2-gang, 6 position switch.
 Filament transformers — 6.3 v., 6 a. to fit under chassis.

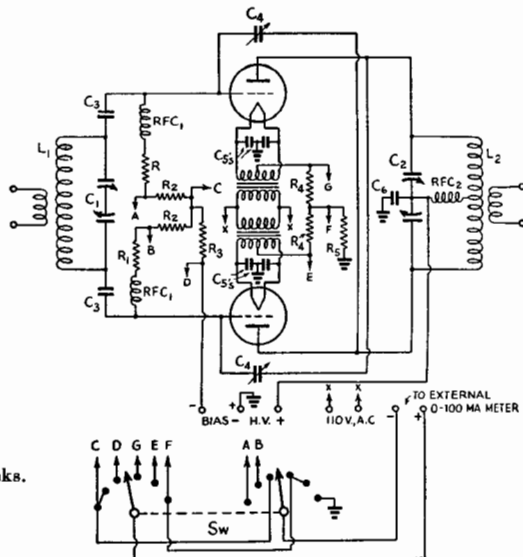

coupling into a tuned line, a separate antenna tank of series tuner should be provided and link coupling used between the final tank circuit and the antenna tank or series tuner. (*Bib. 3.*)

● COMPACT 450-WATT PUSH-PULL AMPLIFIER

The photographs of Figs. 1032, 1033, 1035 and 1036 show an amplifier designed along the lines of the type of construction often referred to as "dish-type." This type of construction has many advantages, although its use is normally confined to components of moderate physical dimensions and weight.

The tank coils may be mounted so that very little metal of the normal rack structure is in the immediate fields of the tank coils — a condition almost impossible to approach in the usual form of construction with metal panels and side brackets. Plug-in coils are made much more accessible for changing and the direction of "pull" in removing coils is outward away from the rack rather than upward into the next rack unit above. Terminals may be mounted so that the wiring between rack units may be made inconspicuous and so that the chances of personal injury from accidental contact with exposed terminals at the rear are greatly reduced. Lastly, this form of construction usually reduces the required height of the unit which is a particular advantage in table racks where vertical space is at a premium.

Individual Metering

The circuit of the amplifier shown in the diagram of Fig. 1034 is standard in every way

except in the method of metering where a departure is made from usual practice. By means of the two-gang six-position switch, it is possible to measure the individual grid and cathode currents of each tube as well as total grid or total cathode currents. To accomplish this, two small filament transformers are used, one for each tube, instead of a single large transformer. The meter is switched across shunting resistances in each circuit to simplify switching. The shunting resistances in the grid circuits are not critical in value so long as they are not less than 20 times the resistance of the 100-ma. meter. Meter resistance usually runs between 0.25 and 1 ohm in the 100-ma. size so that resistances of 25 ohms or so will have no practical effect upon the meter reading. In the cathode circuits, the shunting resistors should be carefully adjusted to provide a scale multiplication of ten. The full-scale readings when the meter is shifted to the cathode circuits will then be 1000 ma. These resistances in each case should be one-ninth of the resistance of the meter used. Those shown in the photograph were made with No. 22 enamelled copper wire wound on ¼" diameter rods of insulating composition. The total length of wire required for each of the resistances is about three feet. The exact length can be determined quite easily by experiment, as described in Chap. 17.

Wiring

In doing the r.f. wiring, care should be taken to keep it as symmetrical as possible. In forming the long wires between the neutralizing condensers and the tank-condenser stators, the lengths should be made identical. The wire connecting to the rear condenser stator should

The Radio Amateur's Handbook

go directly in a straight line, while the one going to the front stator section may be bent to make up for the difference in distance between the neutralizing condensers and the two stators. The plate leads to the tube should be tapped on these long wires at points which will make the wire length between neutralizing condenser and plate and between tank condenser and plate equal on each side.

The positive high-voltage lead, run inside the chassis with high-voltage cable, comes up through a feed-through insulator near the plate choke.

The rotors of the grid tank condenser are not grounded since experience has shown that an amplifier of this type usually neutralizes more readily without the ground connection and excitation usually divides more evenly between the two tubes.

The leads from the neutralizing condensers to the grid terminals are crossed over before they pass through small feed-through points mounted in the partition. The grid r.f. chokes are self-supporting between the tube grid terminals and feed-through points in the chassis which carry the biasing leads inside to the individual grid leaks. Filament wires are run through $\frac{3}{8}$ " holes lined with rubber grommets.

Inside the chassis, the leaks and meter-shunting resistances are supported on fibre lug strips. The leads going to the switch should be soldered in place, formed into cables and the other ends connected to the switch on the panel as the last operation before putting the panel in place. The panel is fastened to the chassis with six 8-32 flat-head machine screws after holes have been drilled and tapped in the folded edges of the chassis.

If the layout and wiring have been followed carefully, no difficulties should be encountered in neutralizing nor with parasitics. Both grid and plate currents should check the same within 10 per cent.

The meter when switched to read grid cur-

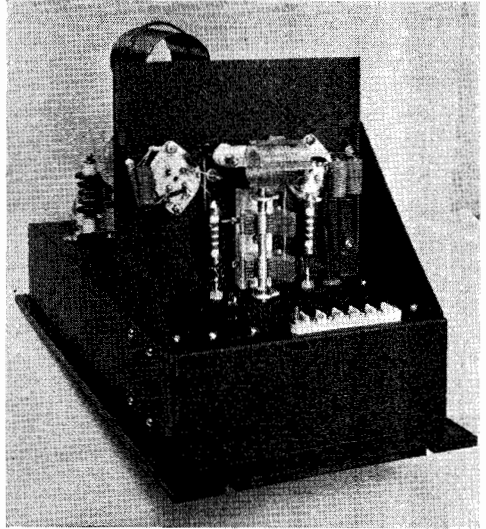

Fig. 1035 — The grid-circuit components of the 450-watt amplifier are mounted on this side of the partition which is braeed by standard 5-in. triangular braekets. The tank condenser is mounted by means of a screw in the hole which remains when the shield between the stators is removed. The ceramic terminal strip is for all external connections except for positive high voltage for which a special safety terminal is provided. A large clearance hole should be cut in the chassis for the condenser shaft. The shaft should come at the center line of the chassis.

rent forms a good neutralizing indicator. Both neutralizing condensers should be kept at equal settings and adjusted simultaneously until the grid current remains perfectly steady as the plate tank is tuned through resonance. When not neutralized, there will be a pronounced dip in grid current at resonance. Neutralizing is always done with plate voltage removed.

The amplifier requires a driver delivering 25 to 40 watts. The 807 exciters of Figs. 1018 and 1022 should prove adequate.

If the amplifier is to be protected with fixed

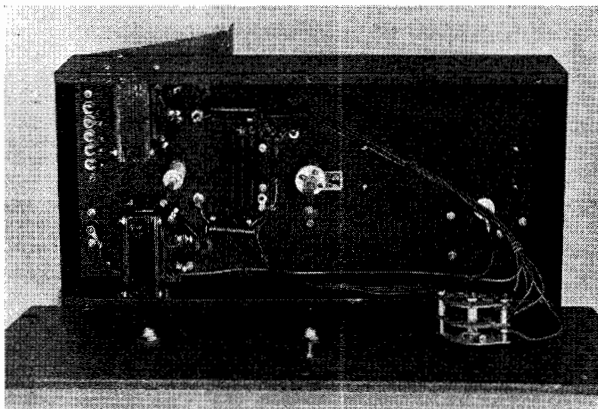

Fig. 1036 — The individual filament transformers are small enough to be mounted inside the chassis. Grid leaks and meter-shunting resistances are mounted between fibre lug strips. The shaft of the grid tank condenser is fitted with an insulating coupling. Meter-switch leads are cabled and connection to the switch made just before the panel is fastened to the 8 in.-by-17 in.-by-3 in. chassis.

Transmitter Construction

bias against failure of excitation, the grid-leak resistance of each tube should be adjusted so that the total grid voltage under operating conditions will be not less than 125 volts without exceeding the maximum grid-current rating of 25 ma. per tube when the amplifier is loaded to rated plate current.

● A 450-WATT BAND-SWITCHING PUSH-PULL AMPLIFIER

The photographs of Figs. 1037, 1038, 1040 and 1041 illustrate a 450-watt push-pull band-switching amplifier capable of handling a power input of 450 watts at 1500 volts for c.w. operation or 375 watts with plate modulation. While the type T55 is shown, any of the tubes of the 1000- or 1500-volt class, such as the 809, T40, HY40, RK35, UH50, 808, 812, RK51 or 35T, may be used.

The circuit is shown in Fig. 1039. Band-switching is accomplished by short-circuiting turns of both plate and grid coils by means of tap switches. Any three adjacent bands may be covered in this manner. By plugging in another pair of coils, a second set of three adjacent

bands may be covered. Thus, the 1.75-, 3.5- and 7-Mc. bands may be covered with one pair of coils, the 3.5-, 7- and 14-Mc. bands with another pair and the 7-, 14- and 28-Mc. bands with a third pair.

A plug-in fixed air condenser is required for the plate circuit for the 1.75-Mc. band. The

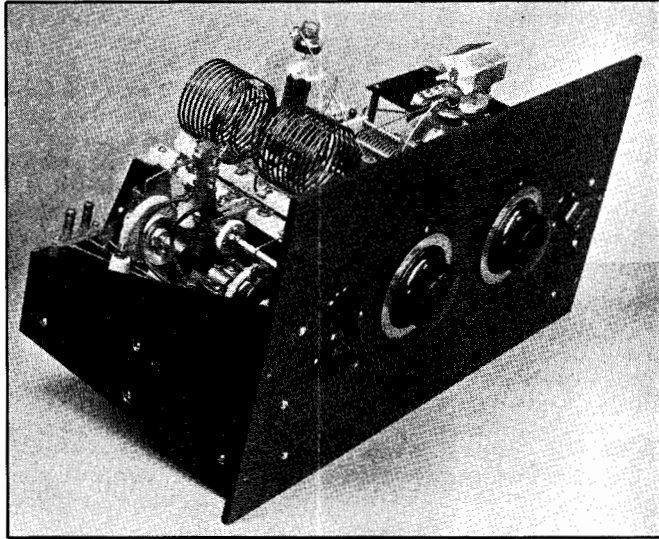

Fig. 1037 — The panel of the band-switching amplifier is 10½ inches by 19 inches. The dials control the plate- and grid-tank condensers. The uppermost of the two small knobs to the left is for adjusting the variable link-output coupling, while the lower one is for the plate band switch. The grid band switch knob is to the right.

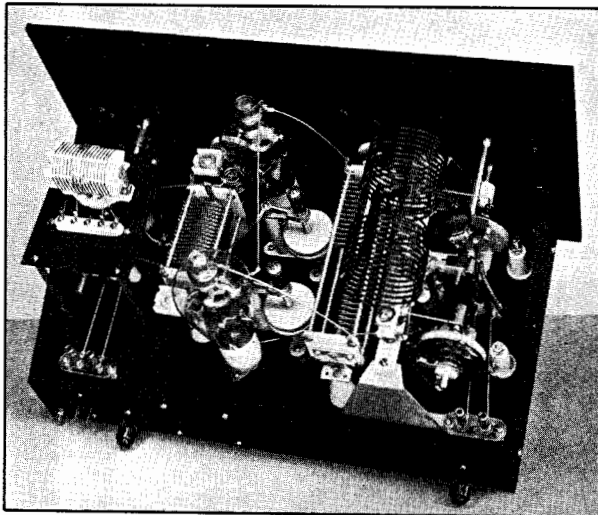

Fig. 1038 — Rear view of the band-switching amplifier. Link input and output terminals are at the left and right-hand ends of the chassis respectively. The parasitic traps are self-supporting between the grid-tank-condenser terminals and the grid terminals of the tubes. The controls of both tank condensers must be well-insulated from the shafts.

plug-in jack base is mounted under the chassis and is wired to the lowest-frequency switch points so that the condenser is automatically connected across the coil when the switch is tuned for the 1.75-Mc. band. When the coil covering this band is not used, the fixed condenser should be removed, or it may be omitted entirely, if operation in this band is not desired. The grid circuit likewise requires padding at 1.75 Mc., but here a 15- μ fd. condenser may be connected permanently across the fourth set of switch contacts which are not used for other bands. C_9-L_3 and $C_{10}-L_4$ are parasitic traps to eliminate ultra-high-frequency parasitic oscillation. Fixed-link coupling is used at the input, with variable-link coupling in the output.

Construction

The plate tank-circuit components are grouped at the left-

The Radio Amateur's Handbook

hand end of the chassis. The tank-coil jack bar is mounted on a pair of metal supports $2\frac{3}{8}$ inches high so that the variable-link control shaft will clear the Ohmite switches by a half-inch or so. The switch units are mounted on 1-inch cone insulators after their mounting brackets have been revamped to bring the shafts $1\frac{1}{2}$ inches above the chassis. The two switch units are spaced on the chassis so as to be central with the connections on the coil jack bar. The shafts are coupled together with a section of $\frac{3}{8}$ -inch bakelite rod with brass reducing couplings at each end. Each end of the bakelite section should be flattened slightly so that the coupling set screw will not slip. The two feed-through insulators at the edge of the chassis are mounted near the switch and are for the connections between the switch units and the padder-condenser jack base under the chassis. The plate tank condenser is mounted on $1\frac{1}{2}$ -inch cone insulators just to the right of the tank coil. The plate r.f. choke and a feed-through insulator for the high-voltage lead are placed beneath the coil mounting. The by-pass C_5 is fastened by heavy wire leads between the grounded front coil bracket and the tank-condenser rotor connection.

On the right side of the chassis the grid tank-

circuit components are grouped. The tank condenser is mounted on $1\frac{1}{2}$ -in. cone insulators to bring its shaft level with that of the plate tank condenser and placed on the chassis so that the two shafts will come at equal distances from the ends of the chassis. Similarly, the grid switch is mounted on a 1-in. cone insulator after a metal bracket has been fashioned to bring the shaft $2\frac{1}{4}$ inches above the chassis. It is placed with its shaft and the shaft of the plate switch at equal distances from the chassis edges. The grid tank coil is mounted on a sheet of metal 4 inches by 5 inches, elevated above the switch by four metal pillars 4 inches high. The grid-circuit r.f. choke and a feed-through point for the biasing voltage are between the tank coil and condenser.

The tubes and neutralizing condensers are placed symmetrically between the two tank circuits. A half-inch hole, lined with a rubber grommet, is drilled under each tube socket for the filament leads.

Coils

The plate-tank coils listed under the circuit diagram are of a special series designed primarily for use with a multi-section tank con-

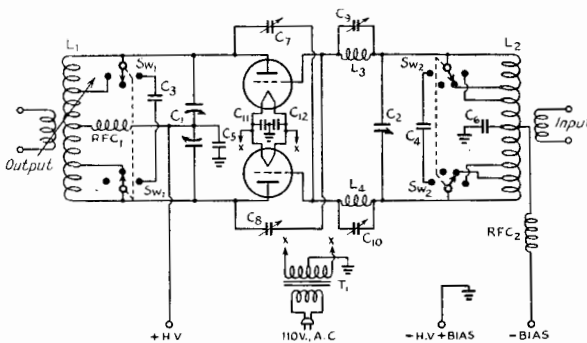

Fig. 1039 — Circuit diagram of the 450-watt band switching amplifier.

- C₁ — 100 μ fd. per section, 0.07-in. plate spacing (Hammarlund HFBD-100-E).
- C₂ — 150 μ fd., plate spacing 0.05-in. (Hammarlund HFB-150-C).
- C₃ — 50- μ fd. fixed air padder for 1.75 Mc., spacing 0.17 in. or greater (see text) (Cardwell JCO-50-OS).
- C₄ — 15- μ fd. padder for 1.75 Mc., 0.05-in. spacing (see text) (Hammarlund HFA-15-E).
- C₅ — 0.001- μ d. mica, 7500-volt (Aerovox 1623).
- C₆ — 0.01- μ d. paper.
- C₇, C₈ — Neutralizing condenser (National NC800).
- C₉, C₁₀ — Isolantite mica adjustable trimmer, 20–100 μ fd. (Mallory CTX954).
- C₁₁, C₁₂ — 0.01- μ d. paper.
- RFC₁ — 1-mh. r.f. choke, 600-ma. (National R154).
- RFC₂ — 2.5-mh. r.f. choke (Millen).
- SW₁ — Ganged sections of Ohmite ham-band switch (3-position).
- SW₂ — Ganged sections of Mallory ham-band switch (4-position) (type 162C).

T₁ — 7.5-volt, 6-amp. filament transformer (Thordarson T19F94).

L₁ — For 1.75-, 3.5- and 7-Mc. bands — 60 turns No. 16, $5\frac{1}{2}$ -in. long, $2\frac{1}{2}$ -in. diam., tapped at the 7th and 16th turn each side of center (B & W TVH-160) (90 μ hy., tapped each side of center at 7/30 and 8/15 of total number of turns in each half).

For 3.5-, 7- and 14-Mc. bands — 38 turns No. 14 $5\frac{1}{4}$ -in. long, $2\frac{1}{2}$ -in. diam., tapped at the 4th and 9th turn each side of center (B & W TVH-80) (35 μ hy., tapped each side of center at 2/19 and 9/38 of total number of turns in each half).

For 7-, 14- and 28-Mc. bands — 24 turns No. 12 $5\frac{1}{4}$ -in. long, $2\frac{1}{2}$ -in. diam., tapped at 2nd and 5th turns each side of center (see text for alterations) (B & W TVH-40) 13 μ hy., tapped each side of center at approx. $\frac{1}{6}$ and $5\frac{1}{2}$ of total number of turns in each half. (See text on adjustment.)

L₂ — For 1.75-, 3.5- and 7-Mc. bands — 52 turns, 2-in. long, $1\frac{1}{2}$ -in. diam., tapped at 9th and 17th turns each side of center. (Coto CS160C) (56 μ hy. tapped each side of center at 9/26 and 17/26 of total number of turns in each half).

For 3.5-, 7- and 14-Mc. bands — 26 turns, $1\frac{1}{2}$ -in. long, $1\frac{1}{2}$ -in. diam., tapped at 5th and 9th turns from each side of center. (Coto CS80C) (17 μ hy., tapped each side of center at 5/13 and 9/13 of total number of turns in each half).

For 7-, 14- and 28-Mc. bands — 16 turns $1\frac{1}{8}$ -in. long, $1\frac{1}{2}$ -in. diam., tapped at 1st and 3rd turns each side of center. (Coto CS40C) (5 μ hy., tapped each side of center at $\frac{1}{8}$ and $\frac{3}{8}$ of total number of turns in each half).

L₃, L₄ — 8 turns No. 12, $\frac{1}{2}$ -in. inside diam., $1\frac{1}{8}$ -in. long.

Transmitter Construction

denser. They are provided with four extra plugs which are used, in this case, for the short-circuiting taps. The coil covering 7, 14 and 28 Mc. requires slight alteration, however. Two turns on each side of center are cut free from the supporting strips and left self-supporting, otherwise the coil heat usually developed at 28 Mc. may be sufficient to ruin the base strip. At the same time, these two turns on each side should be reduced in diameter to $1\frac{1}{8}$ inch. This may be done quite readily by unsoldering the central ends, twisting the turns to the smaller diameter and cutting off the excess wire. While the lower-frequency taps may be soldered, it is advisable to use clamps on the wire for the 28-Mc. taps. Johnson coil clips are just right for the purpose.

Since grid coils are unobtainable with sufficient pins in the mounting, the taps for the grid coils are brought out to a 5-prong Millen coil-mounting bar (Type 40205). A plug-in socket for the bar is sub-mounted in back of the coil socket.

Wiring

All of the wiring, excepting the power wiring underneath the chassis is done with No. 14 tinned bus wire. In all possible cases, connections are made with short straight sections of wire running directly from point to point. Of importance are the leads to the tube grids and plates. The leads to the tank condensers and those to the neutralizing condensers are kept entirely separate; at no point are these leads

common. This practice helps in the prevention of parasitic oscillations. The grid by-pass condenser is mounted close to the grid-coil socket. Millen safety terminals are used for the bias and high voltage.

Tuning

The first step in adjusting the amplifier is that of setting the bias. If T55's are used, a 90-volt battery with 2000-ohm grid leak in series may be connected across the biasing terminals or, if a pack is used, it should be adjusted so that 90 to 150 volts from the pack appear across a 4000-ohm grid-leak section (see Chap. Eleven). Either of the 807 excitors previously described will supply adequate excitation. The only alteration is in the 807 plate coil for 28 Mc. which should be reduced by one turn to provide a higher-C circuit for better matching.

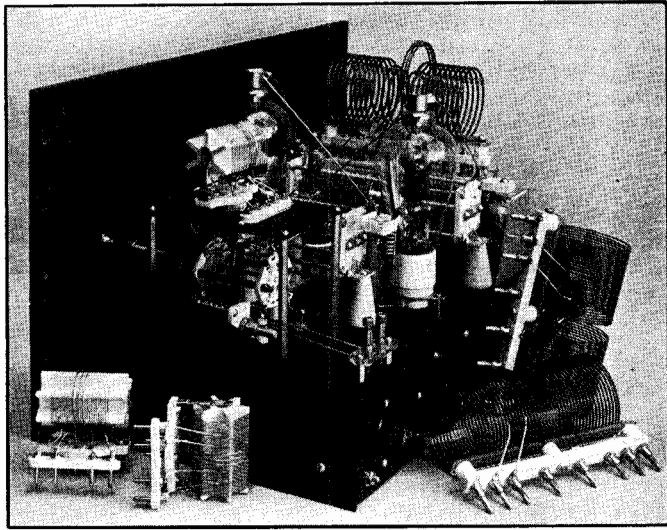

Fig. 1040 — Grid-circuit end of hand-switching push-pull amplifier showing switching arrangement and the 1.75-Mc. paddler.

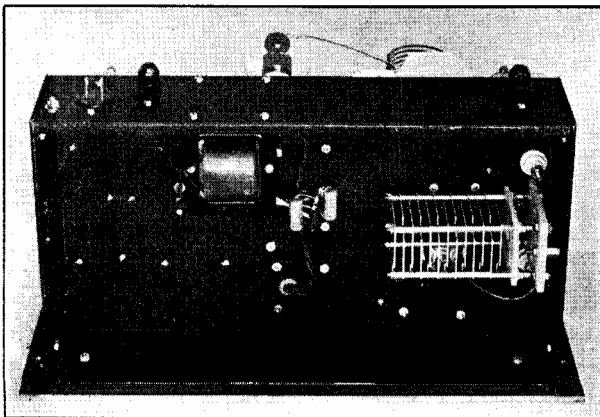

Fig. 1041 — The chassis for the hand-switching amplifier is 10 inches by 17 inches by 3 inches. The plug-in air padding condenser for 1.75 Mc. is spaced with equal distance between top and bottom of the chassis. Filament by-pass condensers are soldered to the terminals of the fibre lug strip to which the filament transformer terminals are anchored.

The Radio Amateur's Handbook

Before excitation is applied, the two condensers C_9 and C_{10} should be set at maximum capacity. With excitation applied and plate voltage off, grid current to the amplifier should run between 60 and 90 ma. Make certain that the coil switches are set at the appropriate points. The amplifier may be neutralized, using the grid meter as an indicator.

The amplifier should now be tested for parasitic oscillation. The bias should be reduced to a point which will allow a plate current of 100 ma. or so to flow without excitation. It is advisable to lower plate voltage for this test by inserting a resistance of about 2500 ohms in series with the plate voltage or inserting a 200-watt lamp in series with the primary winding of the plate transformer. The grid tank condensers should be set at various points while the plate tank condenser is swung through its range. The plate current should remain perfectly stationary. If a point is found where a sudden change in plate current takes place, C_9 and C_{10} should be adjusted, bit by bit, until the variation in plate current disappears. C_9 and C_{10} should be set as close to maximum capacity as possible and yet eliminate the parasitic.

Normal biasing voltage may now be replaced and the amplifier tuned up and loaded. For c.w. operation, the output should exceed 300 watts when operated at the maximum rated input of 1500 volts, 300 ma. With plate modu-

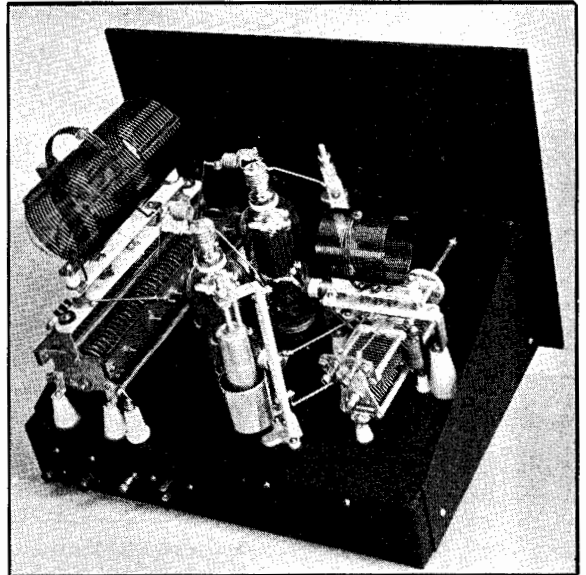

Fig. 1043 — Rear view of the 1-kw. amplifier showing wiring and placement of parts.

lation, the plate current should be reduced to 250 ma. and the output should exceed 250 watts. The amplifier will operate satisfactorily with grid current of 40 to 70 ma. with the amplifier loaded. The maximum rating of 80 ma. for the two tubes should not be exceeded. Reference should be made to the tube tables of Chapter 20 for operation of other tubes.

● PUSH-PULL 1-KW. AMPLIFIER

The push-pull amplifier shown in the photographs of Figs. 1042, 1043 and 1045 is capable of handling a power input of 1000 watts for c.w. operation or 900 watts with plate modulation.

The circuit is shown in Fig. 1044. Plug-in coils with fixed links are used in the grid circuit, while the output-coil mounting is provided with variable-link coupling. L_3C_3 and L_4C_4 form traps against u.h.f. parasitic oscillation. A multi-section plate tank condenser provides a low-minimum capacity for operation at the higher frequencies and a high maximum for the lower frequencies.

Construction

The plate tank condenser is mounted on $1\frac{1}{4}$ -in. cone insulators. The rotor is grounded through a high-voltage fixed condenser at the front end of the condenser. The shaft is cut off and is fitted with a large isolantite

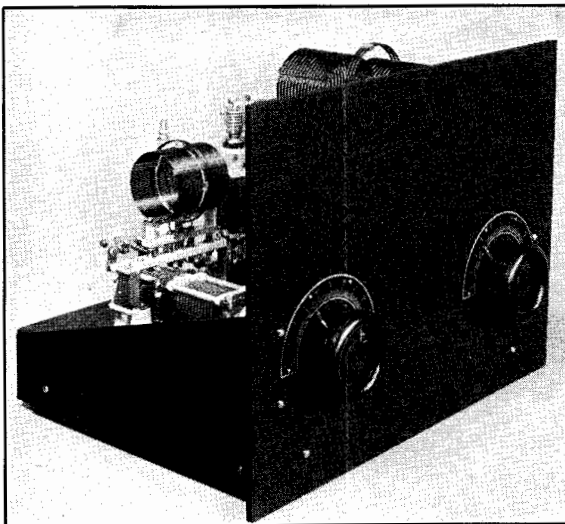

Fig. 1042 — The panel for the 1-kw. push-pull amplifier is 14 inches high by 19 inches wide.

Transmitter Construction

flexible shaft coupling. This is important since the rotor is at high voltage. A panel-bearing assembly is fitted in the panel. The jack bar for the plate tank coil is mounted on a pair of angle brackets fastened to the condenser end plates. Two 300-ma. r.f. chokes in parallel are used with one connected between each condenser end plate and the center connections of the coil jack bar. The positive high voltage comes up through the chassis through a feed-through insulator at the rear of the condenser.

The grid tank condenser is mounted on $\frac{5}{8}$ -in. cone insulators topped with spacers to bring its shaft up level with that of the plate tank condenser. The two condensers are mounted with their shafts $3\frac{1}{8}$ -in. from the chassis edges. The jack bar for the grid tank coil is mounted on "U"-shaped brackets made from $\frac{1}{2}$ -in.-wide brass strip and these, in turn, are mounted on 2-in. cone insulators. The rotor of the condenser is grounded to the chassis at the center. The grid r.f. choke is mounted on a feed-through insulator carrying the biasing voltage up through the chassis. The grid bypass condenser is soldered between the top of the choke and the rotor ground connection.

The two tubes are mounted centrally in respect to the two tank condensers with the neutralizing condensers between the tubes and the grid tank condenser. The sockets for the tubes are sub-mounted beneath the chassis on $\frac{5}{8}$ -in. spacers to bring the plate terminals lower. The parasitic-trap condensers and coils

are self-supporting and are fastened to the heat-radiating plate connectors.

Underneath the filament transformer is mounted and the filament by-pass condensers are wired directly at the sockets. Millen safety terminals are provided for the positive-high-voltage and negative-bias terminals. A male plug is set in the rear edge of the chassis for the 110-volt connection to the filament transformer.

Tuning

The only departure from ordinary procedure in tuning is that of adjusting the parasitic traps. The trap condensers should be set near maximum capacity, but not screwed up tight. After the amplifier has been neutralized, a bias of about $22\frac{1}{2}$ volts should be applied to the grid and the plate voltage applied through a 2500-ohm resistance. With any pair of coils plugged in, the plate current should not vary with any setting of grid or plate condensers. If the plate current changes suddenly at any point, the trap condensers should be adjusted equally until the change disappears. The trap condensers should be set as near maximum capacity as possible consistent with parasitic suppression. If the r.f. wiring has been followed carefully, the initial adjustment of the traps described above should be sufficient.

After the above adjustment is complete, excitation may be applied and the amplifier loaded. The high-capacity sections of the

Fig. 1044 — Circuit diagram for the 1-kw. push-pull amplifier.

- C₁ — 150 μ fd. per section, 0.05-in. spacing (Johnson 150FD20).
- C₂ — Multi-section, max. capacity 228 μ fd. per section, 0.84-in. spacing (Cardwell XE-160-70-XQ).
- C₃, C₄ — 30- μ fd. mica trimmer condensers with isolantite insulation (Millen 28030).
- C₅, C₆ — Neutralizing condensers (Johnson N250).
- C₇ — 0.01 μ fd. paper, 600-volt.
- C₈ — 0.001 μ fd., mica, 10,000-volt (Aerovox 1624).
- C₉, C₁₀ — 0.01 μ fd. paper.
- RFC₁ — 2.5-mh. r.f. choke.
- RFC₂ — 1-mh., 300-ma. r.f. choke (National R-300).
- T₁ — 10-volt, 10-amp. filament transformer (Thordarson T19F87).
- L₁ — 1.75 Mc. — 42 turns No. 14, 3 in. long, $3\frac{1}{2}$ in. diam. (110 μ hy.)
- 3.5 Mc. — 32 turns No. 16, $2\frac{3}{4}$ in. long, $2\frac{1}{2}$ in. diam. (40 μ hy.) (B & W 80BL).
- 7 Mc. — 20 turns No. 14, $2\frac{1}{2}$ in. long, 2 in. diam. (12 μ hy.) (B & W 40BL).
- 14 Mc. — 10 turns No. 14, $2\frac{1}{2}$ in. long, 2 in. diam. (3 μ hy.) (B & W 20BL).
- 28 Mc. — 6 turns No. 12, $2\frac{1}{2}$ in. long, 2 in. diam. (1 μ hy.) (B & W 10BL).
- L₂ — 1.75 Mc. — 48 turns No. 14, $6\frac{1}{8}$ in. long, $3\frac{1}{2}$ in. diam. (90 μ hy.) (B & W 160HDVL).

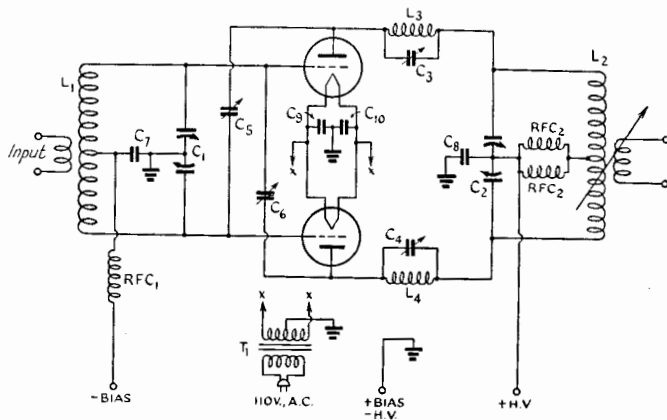

- 3.5 Mc. — 32 turns No. 10, $6\frac{1}{8}$ in. long, $3\frac{1}{2}$ in. diam. (40 μ hy.) (B & W 80HDVL).
- 7 Mc. — 20 turns No. 8, $6\frac{1}{8}$ in. long, $3\frac{1}{2}$ in. diam. (15 μ hy.) (B & W 40HDVL).
- 14 Mc. — 8 turns No. 8, $4\frac{1}{4}$ in. long, $3\frac{1}{2}$ in. diam. (3 μ hy.) (B & W 20HDVL with one turn removed from each end).
- 28 Mc. — 4 turns $3/16$ -in. copper tubing or No. 4 wire, $5\frac{1}{4}$ in. long, $2\frac{3}{8}$ in. inside diam. (0.8 μ hy.) (B & W 10HDVL with one turn removed from each end).
- L₃, L₄ — 6 turns No. 12, $\frac{1}{2}$ -in. inside diam., $\frac{3}{4}$ in. long.

The Radio Amateur's Handbook

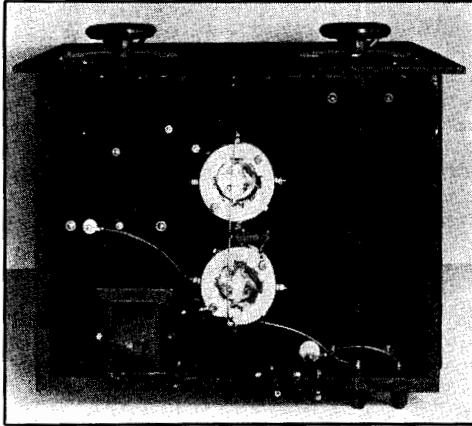

Fig. 1045 — The tube sockets of the 1-kw. amplifier are sub-mounted. The filament transformer is mounted near the sockets. The chassis is 13 inches by 17 inches.

plate condenser are required only for the 3.5-Mc. band. A driving power of 50 to 60 watts is required for Class-C operation. Either of the 807 exciter units described previously will supply sufficient excitation for Class-C operation with plate modulation at full rated input on all bands except the 28-Mc. band. Here, an exciter with greater output, such as the transmitter shown in Fig. 1026 will be required.

A pack delivering 75 to 175 volts is required for biasing. The bleeder resistance, which forms the grid leak, should be set at 2000 ohms. If the pack delivers an output voltage greater than 175 volts, the output should be provided with a voltage divider with resistance values determined as described in connection with Fig. 1112.

Grid current should run 100 ma. on all bands and the amplifier may be loaded until the plate current increases to 500 ma. when the output at 2000 volts should be approximately 750 watts.

● ANTENNA COUPLERS

The small antenna tuner shown in Figs. 1046 and 1048 is designed particularly to go with the 6L6 oscillator transmitter of Fig. 1003, but is suitable for any low-power transmitter operating at plate voltages up to about 500. It is built on a chassis of similar size — 4 in. by 5 in. by 3 in. The tuning condenser is insulated from the chassis by drilling a pair of $\frac{1}{2}$ -in. holes $\frac{3}{4}$ -in. apart to fit National FWB terminal strips. The shoulders on one of the strips are filed off so that the condenser mounting screws will clamp the strips in place.

The placing of the condenser on the chassis is such that its shaft falls the same distance from the center line of the chassis as the shaft

of the condenser in the unit described in Fig. 1003, but on the opposite side of the center line. This will permit a symmetrical panel arrangement when the three units are assembled as a complete transmitter as shown in Fig. 1305.

The antenna windings should be connected as shown in the circuit diagram of Fig. 1047. The size of L_1 will depend upon the antenna dimensions and should be adjusted so that the antenna circuit will tune to resonance. The link winding L_2 , usually of a few turns wound $\frac{1}{4}$ -in. or so below L_1 on the form, should be adjusted in conjunction with the output link of the transmitter to provide proper coupling. This coupler may be used in conjunction with a simple voltage-fed antenna, in which case parallel tuning will be used and the antenna connected to one output terminal, or with tuned feeders.

Fig. 1049 shows the circuit diagram of a simple series-parallel antenna tuner. The constants given will usually be satisfactory for most common lengths of feeders when used with transmitters operating at 1500 volts or less.

The condensers are mounted on pillars taken from National GS-1 insulators as described in connection with Fig. 1053. The coil strip is fastened to the inside upper corners of the condenser frames. Clips on flexible leads are provided to short-circuit unused turns of the antenna-circuit coil and another pair is used to switch from series to parallel tuning. When

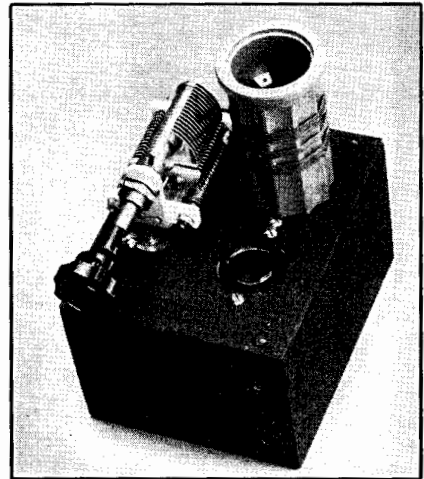

Fig. 1046 — Compact plug-in type antenna tuner for low-power transmitters. The tuning condenser is insulated from the chassis by means of a pair of National FWB terminal strips. The front socket is for parallel tuning, the rear one for series tuning. The clearance hole at the rear of the condenser is for the connection to the condenser stator. The rotor connection is taken off underneath.

Transmitter Construction

series tuning is used, the flexible leads with the clips hang free, while they are clipped on each feeder connection as shown in Fig. 1049 when parallel tuning is desired. Feeder connections are made to the two large stand-off insulators shown in the photograph.

Wide-Range Antenna Coupler

The photograph of Fig. 1051 shows the construction of a wide-range antenna coupler. A separate coil is used for each band and the

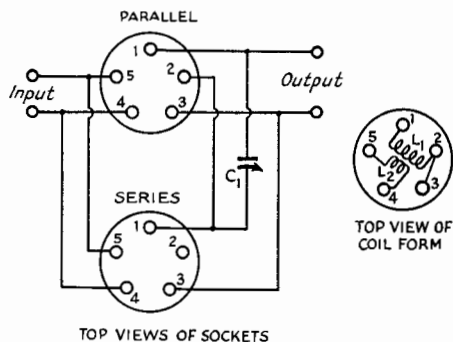

Fig. 1047 — Circuit diagram of the low-power antenna tuner. C_1 is a 250- μ fd. midget variable condenser (National STH250). L_1 is the antenna tuning winding, while L_2 is a link input winding. Connections for series or parallel tuning are made automatically when the coil is plugged into the correct socket.

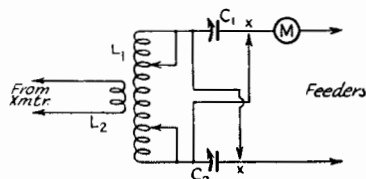

Fig. 1049 — Circuit diagram of the antenna-tuning unit.
 C_1, C_2 — 100 μ fd., 0.07-inch spacing (National TMC-100).
 L_1 — 22 turns No. 14, diameter $2\frac{3}{4}$ inches, length 4 inches (Coto with variable link).
 L_2 — 4 turns rotating inside L_1 .
 M — R.f. ammeter, 0-2.5 for medium-power transmitters.

desired connections for series or parallel tuning with high or low C or for low-impedance output with high or low C are automatically made when the coil is plugged in. Coil connections to the pins for various arrangements are shown in Fig. 1052.

The condenser specified with a set of regular coils should cover practically all coupling conditions likely to be encountered. Because the switching of connections requires the use of the central pin, a slight alteration in the B & W unit is required. The link mounting is removed from the jack bar and an extra jack is placed in the central hole. The link assembly is then

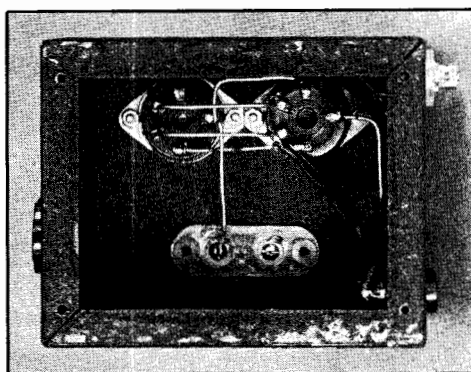

Fig. 1048 — Bottom view of the plug-in type antenna coupler. The pin jacks are the link input terminals, while a pair of National FWB terminal strips is used for the antenna feeder connections.

mounted on a 2-inch cone insulator to one side of the jack bar. On each coil, the central nut is removed and a Johnson tapped plug, similar to those furnished with the coils, is substituted. An extension shaft is fitted on the link shaft and a control is brought out to the panel.

The tank condenser is mounted with angle brackets on four $1\frac{1}{2}$ -inch cone insulators and an insulated coupling provided for the shaft.

If desired, the coils may be wound with fixed links on transmitting ceramic forms. The links will have to be provided with flexible leads to be plugged into a pair of jack-top insulators mounted near the coil jack strip unless a special mounting is made providing for seven connections. Feeder connections are made at the 6-inch spaced terminals at the rear and the connections are brought up through the chassis to the coupler through another pair of feed-through insulators. Similarly, the link line from the final tank circuit is brought to the terminals at the left and thence up through the second pair of feed-through insulators. The latter are mounted so that the flexible connections to the link can be trans-

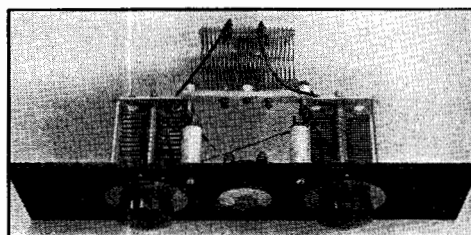

Fig. 1050 — A link-coupled antenna-tuning unit for use with resonant feed systems. The inductance, with variable link, is mounted on the condenser frames. Clips are provided for changing the number of turns, and for switching the condensers from series to parallel. The panel measures $5\frac{1}{4}$ by 19 inches.

The Radio Amateur's Handbook

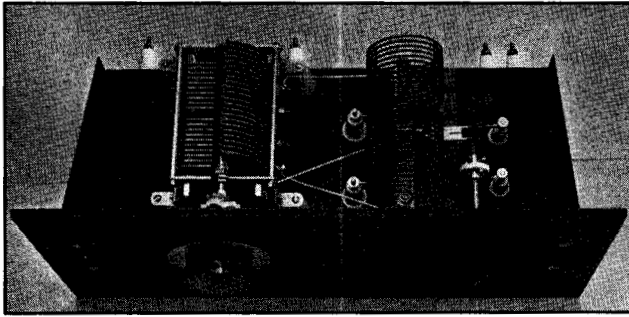
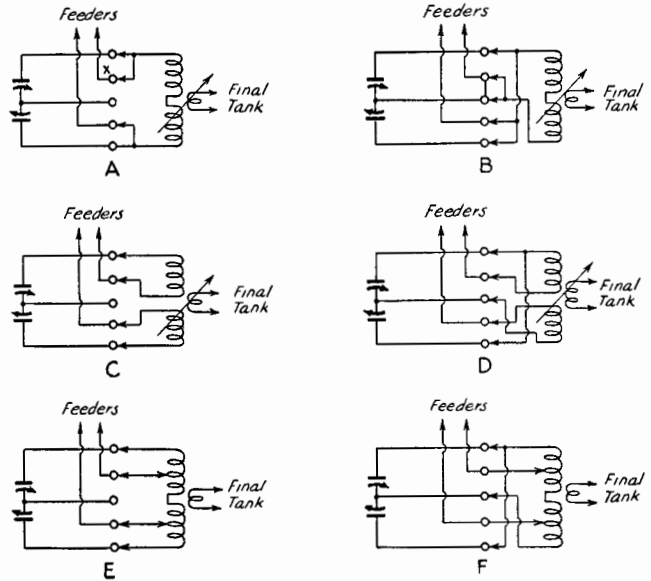

Fig. 1051 — Wide-range antenna coupler. The unit is mounted on a chassis 7 in. by 17 in. by 2 in. with a panel 8 3/4 in. by 19 in. The condenser is a split-stator unit having a capacity of 210 $\mu\text{fds.}$ per section, 0.07-in. plate spacing (Cardwell XT-210-PD). The coils are the B & W TVL series.

Fig. 1052 — Circuit diagram of the wide-range antenna coupler. A — Parallel tuning, low C. B — Parallel tuning, high C. C — Series tuning, low C. D — Series tuning, high C. E — Parallel tank, low-impedance output, low C. F — Parallel tank, low-impedance output, high C. For single-wire matched-impedance feeders, the arrangements of E or F would be used with a single tap instead of the double tap shown. For simple voltage-fed antennas, the arrangement of A would be used with the end of the antenna connected at "X."



ferred from their usual anchorages to prevent short-circuiting against the link shaft.

After the inductance required for the various bands has been determined experimentally, the connections to the coils can be made permanent and then it is merely a matter of plugging in the right coil for each band and tuning the condenser for resonance and adjusting the link for loading.

The unit should be satisfactory for transmitters operating at a plate voltage of not more than 1500. For higher voltages, a condenser with larger spacing should be used.

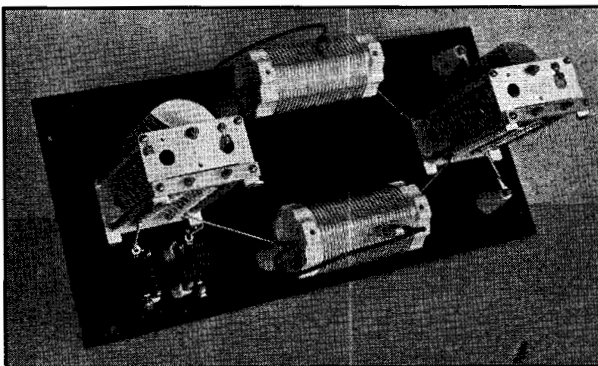

Fig. 1053 — Pi-section type antenna coupler. All parts are mounted on a Presdwood panel 8 3/4 in. by 19 in.

Pi-Section Antenna Coupler

The photograph of Fig. 1053 shows the constructional details of a pi-section-type antenna coupler. The diagram appears in Fig. 1054. All parts are mounted directly on the panel with flat-head machine screws. The condensers are each supported on three ceramic pillars from National type GS-1 stand-off insulators. A 3/4-inch 6-32 machine screw is inserted in one end of each pillar and turned tight. The head of the screw is then carefully cut off with a hack-saw and the protruding quarter-inch or so will thread into the mounting holes in the end plate of the condenser. The shaft is cut off about 1/4-inch from the frame and is then fitted with a Johnson rigid insulated shaft coupling (No. 252).

Transmitter Construction

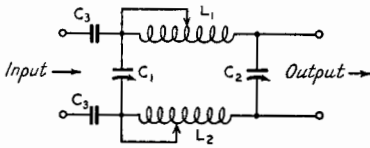

Fig. 1054 — Diagram of pi-section antenna coupler. C_1 - C_2 — 300 $\mu\mu$ fds., 0.07-in. spacing (National TMC-300). L_1 - L_2 — 26 turns No. 14, 2½-in. diameter, 3½-in. long (National XR10A form wound full). C_3 — 0.01- μ fd. mica, 5000 volts.

Since the coupling will extend $\frac{1}{16}$ -inch or so beyond the stand-off insulators, a $\frac{3}{4}$ -inch clearance hole should be cut in the panel for each shaft. Alternatively, $\frac{1}{16}$ -inch thick metal washers could be used between the panel and each pillar to extend the pillar so a clearance hole in the panel would not be required.

Each coil form is supported on 1½-inch cone insulators. The two high-voltage blocking condensers C_3 are also mounted on pillars from GS-1 stand-off insulators. A copper clip on a flexible lead connected permanently to one end

of each coil serves to adjust the coil inductance by short-circuiting turns.

Output connections are made to the two terminal insulators at the right, while input connections are made to the terminals of the two voltage blocking condensers. When single-wire output is desired, the output terminal connected to the condenser rotors is grounded and the coil in that side short-circuited completely by the clip and lead.

Under most circumstances, the components specified will work satisfactorily with transmitters of 400 or 500 watts input operating at plate voltages up to 1500. For higher power, the condensers should have greater spacing and the coils should be wound with No. 12 or larger wire. Couplers for lower power may be made up in similar fashion with smaller components of equal electrical value.

Bibliography

- ¹ "An E.C.O. Exciter with 20-Watts Output", *Mix, QST*, Oct. 1940.
- ² "A Simple Two-Tube Exciter," *Mix, QST*, Nov. 1940.
- ³ "A Compact ¼-kw. Rig", *Mix, QST*, Oct. 1939.

Power Supply

Rectifiers — Filters — Practical Plate and Filament Supply for Transmitters and Receivers — Voltage Dividers — Transmitter Biasing Voltage Supplies — Volt- age Regulation

WHILE the filaments or heaters of all tubes except filament-type battery tubes may be operated directly from a.c. supply, all other tube electrodes in transmitters and receivers require pure d.c. potentials to prevent hum or modulation.

Because of their high initial cost and short life under heavy current drains, advantage may be taken of the excellent characteristics of battery supply with practical economy only in the case of simple receivers and very low-power transmitters. (See Chap. 18.)

The pulsating d.c. output of a motor-generator is readily smoothed to satisfactory limits with a simple filter, but the cost of such a unit is high and such a rotating mechanism is usually objectionable in circumstances under which most amateur installations must be operated. Wherever commercial a.c. lines are available, they are invariably used. Even in cases where an independent supply of any appreciable power must be furnished, the engine-driven a.c. generator is usually to be preferred over other types. For these reasons, this chapter will deal almost entirely with the problem of power supply from a 60-cycle a.c. source. The principles presented may be applied, with corrections which are mentioned, to supplies operating from a.c. sources of frequencies other than 60 cycles.

D.C. from A.C.

To convert the alternating voltage of the supply line (usually 110 or 220 volts) to an essentially pure d.c. voltage of the required level, a transformer-filter system is used. The transformer steps the voltage up to the desired level, the rectifier converts the a.c. to a pulsating d.c. voltage and the filter smooths out the pulsations.

● TERMS AND DEFINITIONS

A *half-wave rectifier tube* is a simple diode consisting of a single plate and cathode.

When two diodes are enclosed in a single envelope, the tube is called a *full-wave rectifier tube*.

A high-vacuum rectifier is one in which the conduction is purely by means of the electronic stream.

A *mercury-vapor rectifier* is one in which a small quantity of mercury has been introduced. During operation, the mercury vaporizes and is broken down into positive and negative ions. The former decrease the normal resistance of the plate-to-cathode circuit.

Inverse peak voltage is the peak voltage which develops between plate and cathode of a rectifier during the portion of the a.c. cycle when the tube is not conducting. In single-phase circuits, it is equal to 1.4 times the total transformer secondary voltage, neglecting transients.

Peak plate current is the maximum instantaneous current passing through the rectifier. For a given load current, the peak plate current is influenced to a certain extent by the design of the filter circuit, specifically, the nature of the filter element immediately following the rectifier.

A *choke-input filter* is one in which a choke is the first element of the filter following the rectifier. This choke is termed the *input choke*.

A *condenser-input filter* is one in which a condenser is the first element of the filter following the rectifier. This condenser is termed the *input condenser*.

A *swinging choke* is an input choke which is designed to increase its inductance with a decrease in load current within specified limits.

A *bleeder resistance* is a resistance connected across the output terminals of a rectifier-filter system. Its purposes are to discharge the filter condensers when voltage is removed and to improve the voltage regulation of the power supply by providing a minimum load.

Voltage regulation is the ratio of the change in output voltage of a power-supply unit between no-load and full-load conditions to the full-load value expressed as a percentage.

Regulation =

$$\frac{\text{No-load voltage} - \text{full-load voltage}}{\text{full-load voltage}}$$

(A drop of 1000 to 900 volts means a regulation of 100/900 or 11 per cent.)

The small fluctuation in voltage remaining in the output of a rectifier-filter system is called the *ripple*. The ratio of the effective value of the *ripple* to the *average* output

Power Supply

voltage is often expressed as *percentage ripple*.

When referring to a power supply, the *load circuit* is the circuit to which its output is connected. The current drawn from the power supply is called the *load current*, or simply the *load*. The same term is sometimes used to indicate *power* furnished to the load circuit by the power supply. The resistance which the load represents, or the *load resistance* is given by dividing the supply-terminal voltage under load by the current being drawn by the load.

(In case some confusion may arise, we speak of *light* or *heavy* loads as those drawing light or heavy currents, or those consuming little or appreciable power. A high-resistance load is a light load; a low-resistance load is a heavy load. The terms *minimum load* and *maximum load* are used in the same sense. Likewise, we say the load increases as the load resistance decreases and the load decreases as the load resistance increases. *Load resistance* is usually mentioned specifically when intended.)

Rectifier Circuits — The Half-Wave Rectifier

The principles of transformers and rectifiers are discussed in Chap. 3. Fig. 1101 shows three typical transformer-rectifier circuits, the most often used type being shown at (3). At (1) is a graph representing the alternating voltage across the secondary terminals of the transformer. In the circuit of the simple half-wave rectifier of (2), the rectifier tube will pass current during that half of the a.c. cycle when the plate end of the transformer is positive in respect to the other end. During the other half of the cycle, when the plate end is negative in respect to the other end, the rectifier will not pass current and no current will flow through the load as illustrated in the second graph. This result in an output voltage pulsating in value but never reversing.

The Center-Tap Full-Wave Rectifier

In order to utilize the remaining half of the wave, two schemes have been devised. At (3) is shown the "full-wave center-tap" rectifier circuit, so called because the transformer secondary winding must consist of two equal parts with a connection brought out from the center. When the upper end of the winding is positive, current can flow through rectifier No. 1 to the load; this current cannot pass through rectifier No. 2 because its resistance is infinite to current coming from that direction. The circuit is completed through the transformer center-tap. At the same time the lower end of the winding is negative and no current can flow through rectifier No. 2. When the current reverses, however, the upper end of the winding is negative and no current can flow through rectifier No. 1, while the lower end is positive and there-

fore rectifier No. 2 passes current to the load, the return connection again being the center-tap. The resulting wave shape is again shown at the right.

The Bridge Rectifier

Another type of full-wave rectifier is shown at (4). Its operation is as follows: When the upper end of the winding is positive, current can flow through No. 2 to the load, but not through No. 1. On the return circuit, current flows through No. 3 back to the lower end of the transformer winding. When the wave reverses and the lower end of the winding becomes positive, current flows through No. 4 to the load and returns through No. 1 to the upper side of the transformer. The output wave shape is shown at the right.

Comparison of Rectifier Circuits

With the circuit of (3), the center-tap full-wave rectifier, all of the a.c. wave is utilized and the amount of power which can be realized at the load is doubled. In order to maintain the same output voltage (instantaneous, not average), as at (2), however, each half of the transformer secondary must be wound for the same voltage as that furnished by the whole winding in (2); or conversely, the total transformer voltage with the connections shown in (3) must be twice the desired output voltage.

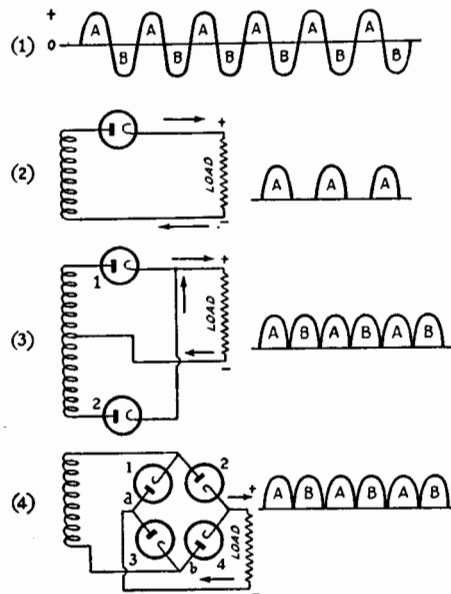

Fig. 1101 — Fundamental rectifier circuits. At (1) is the conventional representation of the a.c. wave; (2) shows a half-wave rectifier; (3) is the full-wave center-tap system, and (4) is the "bridge" rectifier. The output waveform of each type of rectifier is shown at the right.

The Radio Amateur's Handbook

On the other hand, because of the relatively large gaps in the output of the half-wave rectifier (2), considerably more filtering is required to provide a pure unvarying output.

The bridge circuit is useful in cases where the transformer secondary has no center tap or where it is desired to take advantage of the full secondary voltage. It must be remembered, however, that the *power* output obtainable with a given transformer is the same in the case of either (3) or (4). When the circuit of (4) is used with a center-tapped transformer, its current rating must be cut in half. Four rectifier elements, instead of two, are required for this circuit.

● VACUUM-TUBE RECTIFIERS

Practically all rectifiers in use today by amateurs are of the vacuum-tube type. Standard types are listed in the tube tables of Chapter 20 together with their ratings. In the smaller sizes, the tubes are generally manufactured as full-wave rectifiers. Tubes for high voltages are always half-wave rectifiers; two of them are needed for the center-tap system.

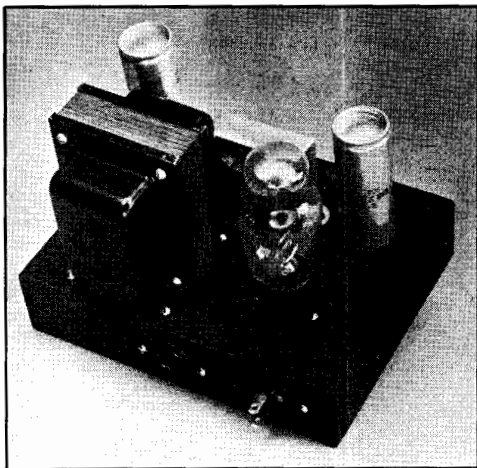

Fig. 1102 — This small unit delivers 480 volts at full-load current of 130 ma. with 0.3% ripple and measured regulation of 17%. By converting to choke-input filter by inserting a similar choke between rectifier and present filter, the output voltage would be reduced to about 300 volts. The chassis measures 7 in. by 9 in. by 2 in. All exposed component terminals are underneath the chassis. Filament and plate terminals are brought out to a 5-prong socket.

Refer to Circuit A, Fig. 1117

Tr — Combination transformer: High-voltage winding delivering 400 v. r.m.s. each side of center; Rectifier filament winding, 5v., 3 a.; R.F. filament winding, 6.3 v., 6 a. (Utah type Y616).

T — Type 83.

L — Filter choke, 10 hys., 175 ma., 100 ohms (Utah type 4667).

C₁ — 4 μ fds., 600 v., Electrolytic (Mallory HS691).

C₂ — 8 μ fds., 600 v., Electrolytic (Mallory HS693).

R — 15,000 ohms, 25 watts.

High-Vacuum Rectifier Tubes

The use of tubes of the high-vacuum type by amateurs is usually confined to power supplies for receivers and low-power transmitter stages. The voltage drop through a rectifier of this type varies with the load current and is higher than that through a mercury-vapor tube, although certain types of the former with closely-spaced elements also involve a low voltage drop at moderate currents. High-vacuum rectifiers are less critical as to operating temperature than the mercury-vapor types. All low-voltage high-vacuum types are designed to work at the specified ratings with either condenser- or choke-input filters. The relatively high internal resistance of tubes of this type make them less susceptible to serious damage from heavy overloads of short duration.

Mercury-Vapor Rectifiers

While either high-vacuum or mercury-vapor tubes may be used at low voltages, the mercury-vapor type is today the universal favorite for high voltages. The voltage drop in these tubes is practically constant at about 15 volts, regardless of the load current, which makes them more efficient and provides better voltage regulation than the high-vacuum types. They are more critical as to operating conditions, however, and more susceptible to permanent damage through overloads of short duration. In operation, tubes of this type may develop "hash"-type interference to near-by receivers unless suitable precautions are taken.

While the lower-voltage types are usually manufactured in the full-wave type and rated according to r.m.s. plate voltage impressed, regardless of the type of filter used, the higher-voltage types are half-wave rectifiers and are rated according to inverse peak voltage and peak plate current as well as average plate current, and the design of the filter must be taken into account in determining the safe maximum operating conditions.

With a properly designed choke-input filter, the peak plate current may not be much greater than the load current, while with a condenser-input filter the peak plate current may be many times the load current.

While both types of rectifier tubes should be operated at the rated filament voltage as measured right at the tube socket, the operating voltage of the mercury-vapor type is more critical if normal life is to be expected. When first installed, or after long periods of idleness, the filament should be turned on for a period of 10 minutes or so before applying plate voltage. If the filaments are turned off during stand-by periods in operating, the

Power Supply

filament voltage should be applied about 15 seconds before the plate voltage.

● FILTERS

In addition to the primary function of a filter, which is to smooth out the pulsations of voltage delivered to it by the rectifier, the design of the filter affects the regulation of the output voltage and the ratio of rectifier peak plate current to the load current. A low ratio of peak rectifier plate current to load current is desirable to assure normal tube life, especially when high-voltage rectifiers are being operated near maximum rated load currents. Good voltage regulation is desirable in most transmitter applications, especially in the cases of self-controlled oscillators and Class-B modulators, although it is of less importance in the case of crystal oscillators (unless keyed), low-power amplifier stages and circuits where the load upon the power supply is more or less constant. Poor voltage regulation is sometimes responsible for key clicks. A regulation of 10 per cent or less is considered excellent.

Experience has shown that a ripple percentage of 5 per cent or less will give "pure d.c." for c.w. telegraphy if the transmitter has high-frequency stability; for radiotelephony and self-controlled oscillators, the ripple percentage should be 0.25 per cent or less, while even a lower percentage of ripple is often found desirable in receiver and speech-amplifier service.

The Condenser-Input Filter

The circuit of the condenser-input filter is shown in Fig. 1103A. No simple formulas are available for computing the ripple with a filter of this type, but experience has shown that it will give excellent smoothing if each condenser is 4 to 8 μ fds. and if the choke has an inductance of 20 to 30 hys. Mercury-vapor tubes which are designed to operate at specified ratings with condenser input are indicated in the table of rectifier tubes. With tubes such as the 866, 866A and 872, the load current must be kept down to 25 per cent of the rated peak plate current of a single tube to prevent exceeding the peak-plate-current rating.

Voltage regulation is usually poorer with the condenser-input filter than with a choke-input filter, ranging from 15 per cent upwards. The output voltage with light loads will approach the peak transformer voltage (1.4 times the r.m.s. value), dropping to the r.m.s. value, or somewhat lower, with heavy loads. The comparative high voltage obtained with this system is its advantage over the choke-input system.

Filter condensers must be rated to withstand the peak transformer voltage.

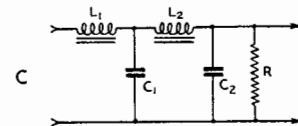
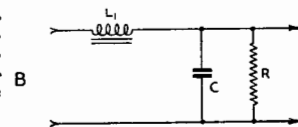
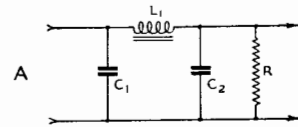

Fig. 1103 — A — Condenser-input filter. B — Choke-input filter, single section. C — Choke-input filter, double section.

Choke-Input Filters

The circuit of a single-section choke-input filter is shown in Fig. 1103B. A close approximation of the ripple to be expected at the output of the filter is given by the formula:

$$\left. \begin{array}{l} \text{Single} \\ \text{Section} \\ \text{Filter} \end{array} \right\} \% \text{ Ripple} = \frac{100}{LC}$$

where L is in henrys and C in μ fds. From this, it may be calculated that the product LC must be equal to or greater than 20 to reduce the ripple to 5 per cent or less. This figure represents, in most cases, the economical limit for the single-section filter. Smaller percentages of ripple are usually most economically obtained with the two-section filter of Fig. 1103C. The ripple percentage with this arrangement is given by the formula:

$$\left. \begin{array}{l} \text{Two} \\ \text{Section} \\ \text{Filter} \end{array} \right\} \% \text{ Ripple} = \frac{650}{L_1 L_2 (C_1 + C_2)^2}$$

For a ripple of 0.25 per cent or less, the denominator should be 2600 or greater.

The Input Choke

The maximum rectifier peak plate current, which in a correctly designed supply occurs simultaneously with maximum load current, may be prevented from rising above the peak rating by the use of a choke-input filter with an input choke of a certain minimum inductance called the *critical inductance*. This inductance in henrys is proportional to the load resistance in ohms and is given by:

$$L_{crit.} = \frac{\text{Load resistance,}}{1000}$$

the load resistance being the total including the bleeder resistance. This formula gives the

The Radio Amateur's Handbook

minimum inductance value which should be used. An increase in inductance will cause a further decrease in the ratio of peak-to-average plate current, especially up to a point where the inductance is twice the critical value. This second value is called the *optimum* value. The critical value is independent of the filter-circuit constants which follow, whose sole function is the further reduction of ripple.

A choke of critical inductance or greater also has the desirable effect of greatly improving the regulation of the output voltage. With less than the critical value, the filter tends to assume the characteristics of the condenser-input filter.

The Bleeder Resistance

It has been said that the critical value of inductance varies with the load resistance. The maintenance of the critical value for loads so light that the current does not approach the maximum rated average is not so important from the standpoint of rectifier-tube peak plate current, but it is important when the regulation of the supply is considered. If good regulation is to be maintained, the supply must always be connected to a minimum load which will permit the use of some reasonable value for critical inductance. This minimum load is usually provided by the selection of a suitable value of resistance for the bleeder which is so important in safeguarding against the danger of injury from undischarged filter condensers. The bleeder resistance in ohms should be not greater than 1000 times the inductance of the choke in henrys at maximum swing for best voltage regulation. Where best regulation is of less importance, the bleeder resistance may be increased to reduce the power consumed.

The Swinging Choke

A choke which would provide critical inductance for a reasonably high value of bleeder resistance and maintain this high inductance at maximum load would be an expensive item. In the swinging choke, advantage is taken of the fact that the critical value of inductance decreases in proportion to the decrease in load from the minimum bleeder load to maximum rated load to the supply. The swinging choke is designed to maintain the critical value, or a greater value, automatically over some specified range, the inductance falling as the load is increased.

Since the choice of choke inductance values is comparatively limited, a choke with a minimum inductance equal to, or greater than, the critical value for the maximum load is usually selected and the bleeder resistance selected so that the inductance of the choke at maximum swing is the critical value for the bleeder load.

Filter Output Condenser

If the power-supply unit is to be used to supply a plate-modulated amplifier the reactance of the power-supply output condenser should be low (not greater than about 20 per cent) in comparison to the load resistance at the lowest audio frequency to be transmitted. Since a low ripple usually requires a capacity of at least 4 μ ds. with available standard chokes, and since the reactance of a capacity of this value will be low for all but the lowest load resistances normally encountered, this value is usually recommended for the output condenser of a power-supply intended for all-around use. Low-voltage high-current supplies require a somewhat higher capacity, 8 μ fds. being a popular figure.

25- and 50-Cycle Supply

The filter design data just given are, as previously mentioned, applicable only to full-wave rectifiers working from a 60-cycle supply line. For lower frequencies, both inductance and capacity must be increased in proportion to the decrease in frequency to maintain the same reduction in ripple. After following through the design for 60 cycles, the inductance and capacity values obtained should both be multiplied by 2.4 to obtain the values necessary for 25 cycles; for 50 cycles the multiplying factor is 1.2. In practice, the 60-cycle design usually will be found to be usable for 50 cycles also.

● EXAMPLE OF POWER-SUPPLY DESIGN

As an example, we shall determine the design data for a supply for a pair of RK51's which, according to rating, require 1500 volts, 150 ma., each, or 300 ma. for the pair. The power supply must have good regulation and a ripple of less than 0.25 per cent.

1. Total Load Resistance

First, let us assume that the bleeder resistance will draw about 20 per cent of the external load of 300 ma. or 60 ma. This means that the maximum current for which the supply must be rated is 360 ma. This total represents a minimum load resistance of $\frac{1500}{0.36}$ or 4166 ohms.

Total load resistance: 4166 ohms.

2. Input Choke

The critical value of the input choke will, therefore, be $\frac{4166}{1000} = 4.16$ henrys, the minimum inductance permissible. We find that we can purchase a choke swinging from 5 to 25 henrys designed to carry a current of 400 ma. Its resistance is given as 60 ohms.

Input choke: 5-25 hys., 400 ma., 60 ohms.

Power Supply

Fig. 1104—This unit delivers either 450 or 560 volts at full-load current of 200 ma. with 0.3% ripple and measured regulation of 16%. Taps are provided on the transformer secondary for the lower voltage. The chassis is 8 in. by 17 in. by 2 in. and the panel 8¾ in. by 19 in. Only the terminals of the filament transformer and chokes appear above the chassis and these units are placed so that there is little danger of accidental contact. A rubber-tubing sleeve should be used to protect the exposed high-voltage terminal.

Refer to Circuit B, Fig. 1117

Tr₁—Secondary: 660 and 550 v. r.m.s. each side center, 250 ma. d.c. rating (Thoradson type T19P55).

Tr₂—5 v., 4 a., 1600 v. insulation (Thoradson type T63F99).

T—Type 83.

L₁—5–20 hys., 200 ma., 130 ohms (Thoradson type T19C35).

L₂—12 hys., 200 ma., 130 ohms (Thoradson type T19C42).

C₁—2 μfds., 1000 v. (Solar type XC-12).

R—8 μfds. Electrolytic, 600 v. (Solar ZV-278).

R—20,000 ohms, 25 watts.



$$C_1 + 4 = \text{square root of } 52 = 7.5$$

$$C_1 = 7.5 - 4 = 3.5$$

A second 4-μfd. condenser will be required for the first filter condenser and the filter design is complete.

First filter condenser: 4 μfds., 2000 v.

3. Bleeder Resistance

The bleeder resistance should be 1000×25 or 25,000 ohms to maintain the correct load resistance for the choke when the external load is removed. A 25,000-ohm bleeder draws exactly 60 ma. at 1500 volts, so our original estimate was correct. The bleeder power rating is determined by $1500 \times 0.06 = 90$ watts. Applying a safety factor we choose:

*Bleeder resistance: 25,000 ohms,
150 watts.*

4. Output Condenser

The output condenser should have a capacity of 4 μfds. Approximately 20 per cent should be added to the d.c. output voltage in determining the voltage rating of the condenser to include safety factor, rise in voltage within the limits of regulation, surges, accidental opening of bleeder, etc. The voltage rating should therefore be 1.2×1500 or 1800 volts. Since intermediate ratings are seldom found, the 2000-volt rating will be chosen.

Output condenser: 4 μfds., 2000 v.

5. Smoothing Choke

For a ripple of 0.25 per cent with a two-section filter, $L_1 L_2 (C_1 + C_2)^2$ must equal at least 2600 (see ripple formula). L_1 and C_2 are known. We can now select from the manufacturer's list a smoothing choke for 400 ma. A smoothing choke of 10 hys., rated at 400 ma., resistance 60 ohms, is obtainable, and we now have all but C_1 .

*Smoothing choke: 10 hys., 400 ma.,
60 ohms.*

6. First Filter Condenser

So, using the formula, we now have:

$$(5)(10)(C_1 + 4)^2 = 2600$$

$$(C_1 + 4)^2 = \frac{2600}{50} = 52$$

7. Transformer

We next take the transformer. We want an output terminal voltage of 1500 d.c. We have in series with the load 2 chokes with a total resistance of 120 ohms. At 360 ma., the voltage drop across these chokes will be 0.36×120 or 43 volts. Assuming the use of mercury-vapor rectifiers, the rectifier drop will be 15 volts (load being drawn through one tube at a time). The total drop is, therefore, 58 volts. This must be added to 1500 to give 1558 volts *average*. The r.m.s. value of the required transformer secondary voltage each side of center tap for a full-wave rectifier is 1558×1.11 or 1730 volts.

The transformer secondary volt-ampere rating may be determined from:

$$\text{Sec. V-A.} = \text{Total } E_{r.m.s.} \times I \times 0.75$$

where $E_{r.m.s.}$ is twice the r.m.s. voltage of each half of the secondary and I is the d.c. output or average current. In our case,

$$\text{Sec. V-A.} = 1730 \times 2 \times 0.36 \times 0.75 = 934 \text{ v-a.}$$

Transformer: 900 v-a., 1730 v., r.m.s. each side of center tap, 360 ma., d.c. or load current.

8. Rectifier Tubes

The peak inverse voltage will be $2 \times 1730 \times 1.4$ or 4850 volts which is well within the rating of the 866 type. The average current of 360 ma. is also well within the average-current rating of the 866. *Rectifier tubes: type 866*

9. Rectifier Filament Transformer

The rectifier filament transformer should have a secondary rated at 2.5 v., 10 a. and

The Radio Amateur's Handbook

should have a tap at the center. The secondary winding should be insulated for at least two or three times the output voltage.

Filter Condensers

Two types of filter condensers are commonly available: electrolytic condensers and condensers using paper as the dielectric. Electrolytic types have the advantage of high capacity and small physical size. They are relatively inexpensive, but in the present state of the art are unobtainable for voltages in excess of 600. "Wet" types of electrolytics will stand temporary overloads better than the "dry" type because the leakage, which is characteristic of all electrolytic condensers, will increase. Either type will be satisfactory for condenser-input filters with transformers delivering not over 350 volts each side of center tap. Electrolytic condensers can be obtained in various capacities; 8 μ fd. is a popular size.

If the maximum voltage of the power supply is greater than the rating of a single electrolytic condenser, two units may be placed in series to handle the higher voltage.

Electrolytic condensers are suitable for use only in d.c. circuits, and must be connected correctly. In the types having a metal container, the container usually is the negative terminal while the stud terminal is positive. A popular condenser for series connection is the double 8 μ fd. condenser having four leads — the can being insulated from the condenser, in this case, and the negative leads are usually black. In any event the polarities are always plainly marked. Reversing the polarity will ruin the condenser.

Condensers having a working-voltage rating equal to the highest output voltage of the power-supply system (see discussion on condenser-input filters) always should be purchased. Paper condensers can be purchased with voltage ratings up to 3000 volts and more. High-voltage condensers of modern design should be purchased from reputable dealers; it does not pay to "economize" by buying a cheap high-voltage condenser. Although the

first cost of a good condenser may be higher, it will last indefinitely if not abused. Poor condensers may work for a time, but eventually may "blow" and have to be replaced. Failure of a high-voltage condenser may also mean the destruction of the rectifier tubes.

Filter Chokes

The inductance of a choke will vary with the current through it and with the value of the ripple voltage impressed on it in the filter; inductance decreases with increasing direct current and with decreasing ripple voltage. In purchasing a choke information should be obtained as to its actual smoothing inductance at full d.c. load current.

Most of the small chokes obtainable from radio dealers are given a commercial rating of 20 or 30 henrys. This rating is meaningless unless the conditions under which the choke's inductance was measured are stated. Fortunately the smaller chokes are inexpensive and usually have enough inductance to work quite well in condenser-input filters; it is better, however, to buy a choke of good make than to trust to luck with a cheap, but unknown, product.

It must be realized that the design formulas given previously are based on *actual* inductance under load conditions; an over-rated choke will nullify the calculations and probably lead to an entirely different order of performance.

● SPECIAL ADAPTATIONS

Figs. 1105, 1106, 1107, 1108 and 1109 show special power-supply arrangements which may make it possible to economize in the cost of apparatus under certain circumstances.

In Fig. 1105 a bridge rectifier is used to obtain the full transformer voltage for a high-voltage stage, while a connection is also brought out from the center tap to obtain a second voltage corresponding to half the total transformer secondary voltage for a driver or some other purpose.

$2I_1$ plus I_2 , where I_1 is the current drawn from the high-voltage tap and I_2 that drawn from the low-voltage tap should not exceed

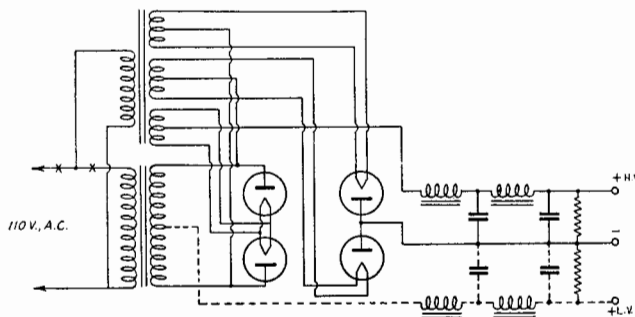

Fig. 1105 — High-power bridge rectifier circuit delivering two voltages provided the plate transformer is center-tapped. When the center-tap filter shown in dotted lines is used, a tap at half maximum voltage with good regulation is provided. The current drawn from both taps should not exceed 500 ma. if 866's are used or 2500 ma. if 872's are used. See text for transformer ratings, etc.

Power Supply

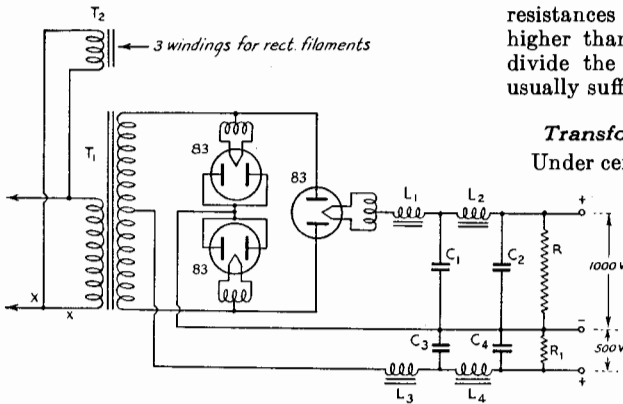

Fig. 1106 — Duplex plate supply using 83's. Filter values determined for load to be used across each set of terminals according to design procedure in text. Transformer must be rated to deliver total current drawn from both branches.

the d.c. current rating of the transformer. The sum of the currents drawn from the two taps should not exceed the d.c. rating of the rectifier tubes. Filter values for each tap should be computed separately as described previously.

Fig. 1106 shows a similar arrangement using three type 83 rectifiers.

Fig. 1107 shows how a transformer with multiple secondary taps may be used to obtain both high and low voltages simultaneously. A separate full-wave rectifier is used at each tap. The filter chokes are placed in the common negative lead, but separate filter condensers are required. Here the sum of the currents drawn from each tap must not exceed the transformer rating and the chokes must be rated to carry the total load current. Each bleeder resistance should have a value in ohms of 1000 times the maximum rated inductance in henrys of the swinging choke, L_1 for best regulation.

Fig. 1108 shows the connection of 866's in parallel in a full-wave rectifier for heavier currents than may be handled by single tubes. So far as the rectifier tubes are concerned, the current rating is doubled and the tubes will handle 1000 ma. with a choke-input filter or 500 ma. with a condenser-input filter. The

resistances in the plate circuits should be no higher than is necessary to make the tubes divide the load evenly; 50 to 100 ohms is usually sufficient.

Transformers and Rectifiers in Series

Under certain circumstances, it is sometimes possible to reduce the cost of a high voltage supply by connecting two similar lower voltage supplies or transformer-rectifier units in series. Such a circuit is shown in Fig. 1109. A pair of inexpensive 600 volt, 200 ma. transformers and type 83 rectifiers may be used in this manner to deliver a d.c. output voltage

through the filter of about 1000 volts. Since the winding of the transformer on the positive side is at a higher potential than normal, some care should be taken to select a transformer with good insulation. Most transformers of reliable manufacture will have sufficient insulation, at least those with output voltage ratings of 600 volts or less each side of center-tap.

Low-Percentage Voltage Regulation

For certain purposes, such as furnishing voltage to operate a self-controlled oscillator at low power in a transmitter or for the oscillator and mixer stages in a receiver, a power supply with voltage regulation as near zero as possible may be required for maximum frequency stability. One of the most satisfactory ways of obtaining this order of regulation is by the use of gaseous voltage-regulator tubes of the VR type.

These tubes, which are obtainable for several different voltages, are designed to maintain a constant voltage drop across the terminals when connected as shown in the diagrams of Fig. 1111. This constant voltage drop is maintained because a property of the tube causes its internal resistance to change in almost exact inverse proportion to the change in voltage across it. As the voltage across the tube tends to increase, its internal resistance decreases, more current is drawn through the limiting resistor, R_1 , and the voltage across the tube is maintained constant. Conversely, if the voltage across the tube tends to decrease, the

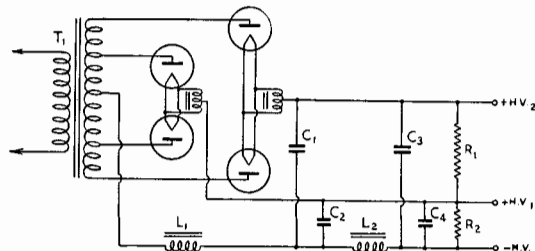

Fig. 1107 — A power-supply circuit in which a single transformer and set of chokes serve for different voltages. Chokes and transformer must be designed to handle total load.

The Radio Amateur's Handbook

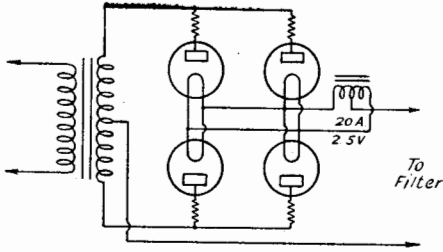

Fig. 1108 — Using 866's in parallel to double the current rating. In this arrangement 866's will deliver 1000 ma. provided the transformer and swinging choke used will handle the capacity. Note the low resistance equalizing resistors in the plate leads.

internal resistance increases, less current is drawn through R_1 and again the voltage across the tube remains constant.

The limiting factors involved are the starting voltage, which is the voltage at which the

Fig. 1110 — This supply delivers either 620 or 780 volts at full-load current of 260 ma. with 0.4% ripple and regulation of 22%. Voltage is changed by a tap on the plate-transformer primary winding. All exposed component terminals are underneath the chassis. The panel is $8\frac{3}{4}$ in. by 17 in. and the chassis 8 in. by 19 in. by 2 in. A rubber-tubing sleeve should be used to cover the exposed high-voltage terminal.

Refer to Circuit C in Fig. 1117

- Tr₁ — 925 or 740 v. r.m.s. each side center, 300 ma. d.c. (Kenyon T656).
- Tr₂ — 2.5 v., 10 a., 2000 v. insulation (Kenyon type T352).
- T — Taylor 866 jr.
- L₁ — 6-19 hys., 300 ma., 125 ohms (Kenyon T510).
- L₂ — 11 hys., 300 ma., 125 ohms (Kenyon T166).
- C₁ — 2 μ fds., 1000 v. (Sprague OT21).
- C₂ — 4 μ fds., 1000 v. (Sprague OT41).
- R — 20,000 ohms, 50 watts.

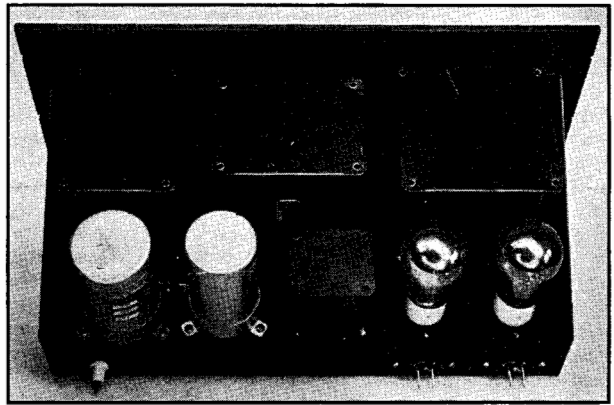

tube will start to conduct and which is somewhat higher than the operating voltage; the minimum current through the tube which will maintain the circuit through the tube and the maximum safe current which the tube will handle.

The voltage of the power supply across which the tube and limiting resistance are connected, must be as great or greater than the starting voltage. The minimum currents at which the tubes will operate satisfactorily

lie between 5 and 10 ma., depending upon the type, while the maximum-current rating is 30 ma. for most types. It is the purpose of R_1 to prevent the current from exceeding this rating. The resistance value to be used for R_1 will depend somewhat upon the nature of the load current to be drawn from the regulated tap as well as upon the voltage rating of the VR tube and the power supply.

In the first case, the regulated tap may be used to feed a load which varies from zero to some definite figure, such as the plate circuit of an e.c.o. which is keyed. With the key open, the load is zero and the VR tube will have to consume the entire load. Since this is limited to a maximum of 30 ma., R_1 will have to have such a value that the drop through it at 30 ma. will equal the difference between the supply voltage and the voltage rating of the VR tube. Since a minimum current of 5 to 10 ma. is required to maintain operation of the

VR tube, the plate current of the e.c.o. tube must not exceed 20 to 25 ma., otherwise, the VR tube will open-circuit and regulation will be lost. The VR tube will, in this case, provide constant voltage with a load current of from zero to 20 or 25 ma.

In a second case, we may have a continuous load, such as the screen voltage-divider resistance of the e.c.o. in addition to the intermittent load of the plate and screen currents. In calculating the value of resistance for

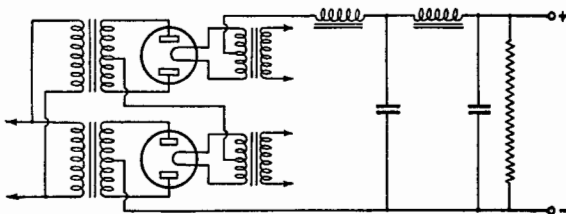

Fig. 1109 — Two transformers and rectifiers connected in series to give higher output voltage.

Power Supply

R_1 in this case, the voltage-divider current should be added to the 30 ma. In this case, the VR tube provides a constant voltage with a load-current range extending from the steady current drawn by the voltage divider to this value plus 20 or 25 ma. Similarly, R_1 should be calculated for any value of steady current which is to be drawn from the regulated tap plus the maximum rated current of the VR tube.

In a third case, we may have a load current which is more or less constant, but which may vary either up or down in value. This applies to the case of regulated supply for a receiver, unless the gain control may cause the load current to change more in one direction than the other. In cases such as this, and in the case of compensation for changes in line voltage, it is best to calculate the dropping resistance using the normal average current drawn by the receiver stages operating from the regulated tap plus one-half the rated current of the VR tube. This will allow more-limited compensation in one direction, but it will take care of both increases and decreases in load current from the average. Effects of the gain control may be taken care of by measuring the normal current to be drawn from the regulated tap with the gain in an intermediate position.

When the regulated voltage desired is higher than the voltage of one tube, a tube with a higher voltage rating may be used, or tubes may be connected in series as shown in Fig. 111B. The power-supply voltage must, of course, be equal to or greater than the combined starting voltages of the tubes in series. When the load-current variation exceeds that which a single tube will handle, tubes may be connected in parallel, or series-parallel for higher current and higher voltage as shown in

Fig. 111C and D. When connecting tubes in parallel, it may be necessary to connect equalizing resistances of 50 ohms or so in series with each tube to obtain even ignition.

When tubes are connected in series, or series-parallel, low-voltage taps may be taken off between the VR tubes, if desired, as shown in the diagrams.

In operation, these tubes exhibit a bluish or yellowish glow when the tube is conducting current, no light of any kind showing when the tube ceases to conduct.

Another type of regulated power supply is described in *QST* for August 1937. In this system a sharp cut-off pentode is used to control the drop through a low-resistance power triode. Those interested are referred to this article.

● FILAMENT SUPPLY

For medium- and high-power r.f. stages of transmitters, and for high-power audio stages, it is considered most desirable to use a separate filament transformer for each section of the transmitter, installing the transformer near the tube sockets and feeding the primary lines instead of the secondary lines through the interconnecting cables of the transmitter. In this way, necessity of abnormally large wires carrying filament power is avoided, and two small, well-insulated leads may be used to carry the total filament power for all stages without appreciable filament voltage drop. This is very important in large stages with heavy-current, low-voltage filaments, since a very small resistance in series with the filament of the stage may reduce the voltage applied to a value at which the tube is likely to be damaged. Loss of emission of power tubes is often caused by under-voltage filament operation, even for short periods of time.

Fig. 1111 — Circuits in which VR tubes are used to obtain essentially constant voltages. At B, two tubes are used in series for greater voltage, at C the tubes are connected in parallel for greater current variation. D shows four tubes connected in series-parallel for both higher voltage and higher current. The method of determining the value of the current-limiting resistor R_1 is described in the text. R_2 , a resistance of about 50 ohms, may be required when tubes are connected in parallel to equalize the ignition. When tubes are connected in series, taps may be taken off for lower voltage as shown in B and D, if desired.

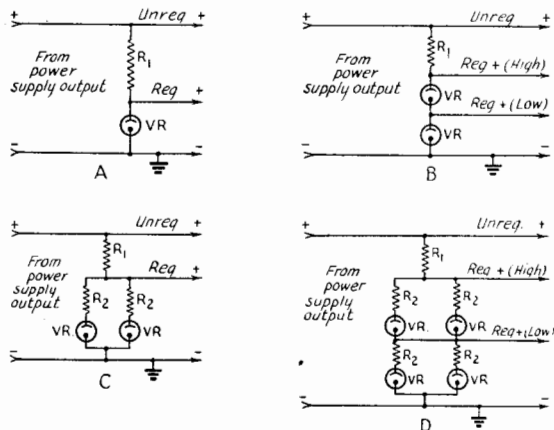

The Radio Amateur's Handbook

● TRANSMITTER BIAS SUPPLY

Low-voltage power packs make excellent substitutes for batteries for certain types of r.f. amplifiers. Not all power packs are suitable, for the purpose unless provided with an appropriate bleeder resistance. Those packs delivering some value of voltage between the cut-off biasing voltage and the value of bias required under operating conditions are most suitable since it is only required that the bleeder resistance be equal to that normally used for grid leak in the amplifier.

If the pack delivers a voltage greater than the required operating value of voltage, the bleeder must be tapped with the proportions discussed under Fig. 1112. In either case, no grid leak should be used in addition to the bleeder resistance.

Since the biasing voltage varies with grid current, a supply of the type discussed will be

Fig. 1113 — Circuit of the automatic vacuum-tube regulator as applied to a bias- or plate-supply power pack. R_1 is the regulator tube's bias resistor and R_2 is the power-pack output voltage divider. A separate filament winding should be used for the regulator. A type 45 tube will be satisfactory as the regulator tube.

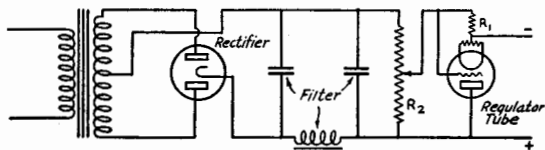

found somewhat unsatisfactory for biasing more than one stage because the grid current for all stages must flow through the same resistance, thus causing some or all stages to be over-biased. This can be avoided under certain circumstances by the use of one or more additional voltage-dividers or bleeders for additional stages. This is usually satisfactory only when the additional bleeders may be of comparatively high resistance and the current

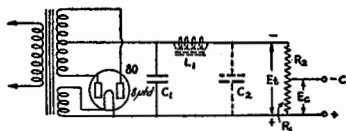

Fig. 1112 — A practical circuit for the "C" supply. A single 8- μ fd. condenser often will suffice for the filter but if trial shows that more is needed, a choke and second condenser, shown in dotted lines, may be added. The condensers should be rated at 500 volts, especially if the "C" supply is to be used on a high-power stage where the excitation is likely to be large.

The bias voltage, E_0 , should be approximately that value which will cut off the plate current of the tube at the plate voltage used (roughly the plate voltage divided by the voltage amplification factor of the tube). Resistor R_1 should be equal to the grid leak value ordinarily used with the tube. The required resistance for R_2 can be found by the formula

$$R_2 = \frac{E_1 - E_2}{E_0} \times R_1$$

where E is equal to the peak value of the transformer-rectifier output voltage (r.m.s. voltage of one side of secondary multiplied by 1.4).

flowing through them small in comparison to that in the first resistance.

This simple type of supply will be unsatisfactory in applications where the biasing voltage must not vary with excitation as in the cases of Class-B audio and r.f. amplifiers. For linear output from these types of amplifiers, it is essential that the bias remain constant under all degrees of excitation.

Bias-Voltage Regulation

To overcome these difficulties, methods have been devised to provide automatic voltage regulation so that the voltage of the bias pack will remain constant with varying grid currents.

A circuit which has been used successfully is shown in Fig. 1113. The stabilizer consists of a tube across the output of the power supply in a self-biasing arrangement. The resistor R_1 is on the order of several megohms, so that at no

load the tube is biased practically to cut-off. The output voltage is then the total voltage of the supply minus the voltage required to bias the regulator tube to zero plate current. When current flows back through the regulator tube, as would happen if the power supply were being used to bias the grid of a tube which was being driven positive and was drawing grid current, the voltage across the regulator tube will tend to increase. This will cause the voltage across the biasing resistor, R_1 , to decrease. Since the sum of the regulator tube drop and the drop through R_1 must equal the total supply voltage, as the voltage across R_1 decreases the bias on the regulator tube decreases, which causes the tube plate impedance to decrease so that the voltage across it tends to remain constant regardless of the current which is flowing back through it.

As the output voltage is lowered, it may be seen that it becomes necessary to increase the number of tubes in parallel to maintain good regulation, so that at low voltages it would be preferable to use batteries for bias, rather than an a.c. supply with this type of regulator.

The value of the resistor R_1 is not critical, so long as it is large enough to maintain the current drawn from the power supply at a very low value. Any value from a few hundred thousand ohms up to several megohms is satisfactory. The voltage divider R_2 can have practically any value, from a few thousand

Power Supply

Fig. 1114 — Circuit diagram of multiple-stage bias supply.

T₁ — Universal bias transformer — taps delivering 75 to 400 volts, 200 ma. (UTC S-52).

T₂ — 5 v., 2 a.

T₃ — 5 v., 4 a.

L₁ — 200-ma. choke, 15–20 hys.

C — 8 μfds., 600-volt electrolytic.

R₁ — 50,000 ohms.

R₂, R₃, R₄, R₅ — See text.

This pack is designed to take care of four transmitter stages.

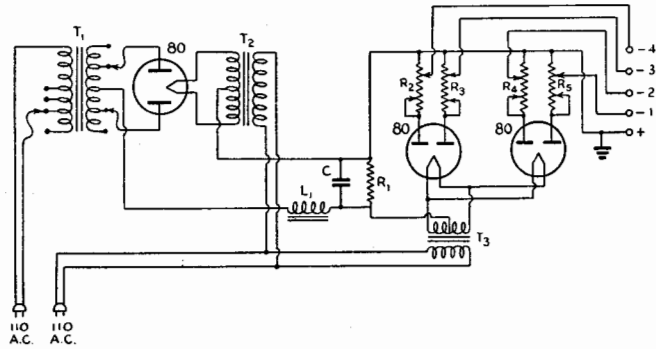

ohms up, as the current drawn is practically zero.

If additional taps are necessary, a regulator tube with its separate filament transformer will be required for each tap.

Multiple-Stage Bias Supply

Fig. 1114 shows the circuit diagram of a bias-pack system in which rectifiers are used to isolate the individual grid resistances for each transmitter stage. Normal bleeder current can flow through the rectifier in each branch and the rectified grid current of any particular stage flows in the normal manner through its own resistance but cannot flow through the other resistances since the other rectifiers are polarized to prevent any such action.

The resistance to be used between the biasing tap and the positive terminal should be equal to the recommended grid-leak resistance for the stage in question (no additional grid leak should be used in the stage). The total resistance in use between the regulating rectifier plate and the positive terminal may then be determined by the following formula:

$$\text{Total } R = \frac{E_o}{E_{\infty}} \times R_b$$

where E_o is the output voltage of the pack, E_{∞} the bias voltage required for plate-current cut off of the tube in question with no excitation and R_b is the recommended grid-leak resistance. E_{∞} is determined approximately by dividing the plate voltage at which the stage is to be operated by the amplification factor of the tube. The short-circuiting tap at the rectifier plate may be used to adjust for the desired total resistance.

In practice, the pack output voltage should be adjusted to a value slightly above that of the highest required cut-off value. This will result in the most economical operation of the pack.

Gaseous-Tube Regulated Bias Supply

A biasing system in which advantage is taken of the regulating properties of the VR-type gaseous tubes is shown in Fig. 1115. Two cases are shown. In the first case, A, the drop across the regulator tube or tubes in series equals or exceeds the maximum cut-off voltage required by any stage and yet does not exceed the minimum operating bias for any stage operating from the supply. In the second case, B, the maximum cut-off bias required for a certain stage or stages may exceed the oper-

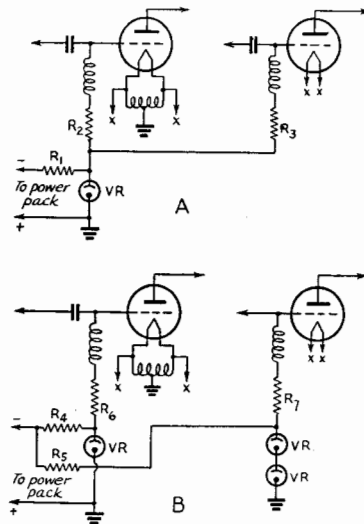

Fig. 1115 — Biasing system using VR tubes in which more than one stage may be operated from the same pack. At A is shown the circuit for use where the cut-off bias required by any stage does not exceed the operating bias of any stage. B shows the circuit where the cut-off bias required by one stage may exceed the operating bias of another stage operating from the same pack. R₁, R₄ and R₅ are the current limiting resistors, while R₂, R₃, R₆ and R₇ are additional grid leak resistances the values of which may be determined from the text. The pack supplying the voltage need have but a small current capacity and a single 2- or 4-μfd. condenser will usually serve as sufficient filter.

The Radio Amateur's Handbook

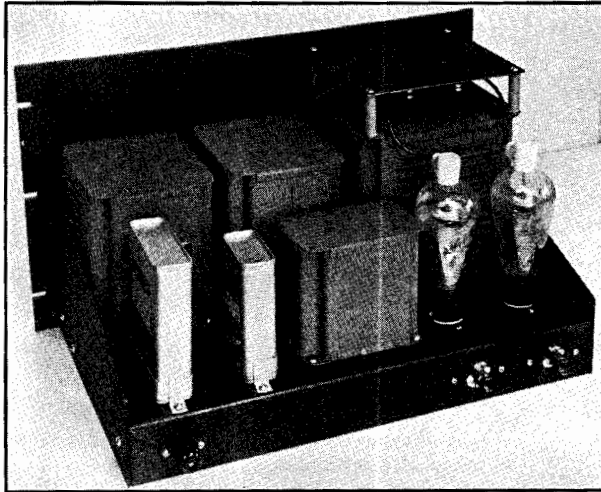

Fig. 1116—This unit delivers 830, 1060 or 1250 volts at full-load current of 250 ma. Voltages are selected by taps on the secondary. Ripple is reduced to 0.25% and regulation checked at 10%. All high-voltage terminals except those of the transformer secondary and tube caps are underneath the chassis. The transformer terminal board is covered with a section of $\frac{1}{8}$ -in. steel panel mounted on pillars at the four corners. Insulating caps are provided for the tube plate terminals. A special separable high-voltage safety terminal (Millen) protects the high-voltage connection. The chassis is 11 in. by 17 in. by 2 in. and the panel $10\frac{1}{2}$ in. by 19 in.

- Refer to Circuit C in Fig. 1117
 Tr₁ — 1500–1250–1000 v. r.m.s. each side center, 300 ma. d.c. (UTC type S47).
 Tr₂ — 2.5 v., 10 a., 10,000 v. insulation (UTC type S57).
 T — Type 866.
 L₁ — 5–25 hys., 300 ma., 90 ohms (UTC type S34).
 L₂ — 15 hys., 300 ma., 90 ohms (UTC type S33).
 C₁ — 2 μ fds., 1500 v. (Aerovox Hyvol).
 C₂ — 4 μ fds., 1500 v. (Aerovox Hyvol).
 R — 25,000 ohms, 100 watts.

ating bias of other stages operating from the supply.

In A, sufficient VR tubes in series should be used to take care of the maximum cut-off bias required, selecting the proper combination of VR types. Sufficient parallel tubes or series of

tubes in parallel should be used to handle the combined grid currents of all stages at the rate of 25 ma. per parallel branch. The output voltage of the supply should at least equal the total starting voltage required by the tubes in use. R_1 in ohms should be equal to the difference between the supply voltage and the regulator-tube drop divided by 0.005. The individual grid leaks for each stage, indicated by R_2 and R_3 , should each have such a value that the voltage drop across the leak due to grid current when added to the constant regulator-tube drop will equal the operating bias required.

In B the same procedure is followed, except that a separate branch with dropping resistor must be used for a stage or stages which require an operating bias less than the cut-off bias required for another stage in the transmitter.

The advantage of this system is that the bias supply is required to handle a very small amount of power — only the idling currents of the VR tubes. It becomes less feasible in cases where both high cut-off voltage and high grid current are required. However, the majority of cases may be handled with 2 to 4 tubes, while a single tube will suffice in many cases.

● POWER-SUPPLY CONSTRUCTION

The wide varieties of rectifying and filtering equipment available to amateurs, together

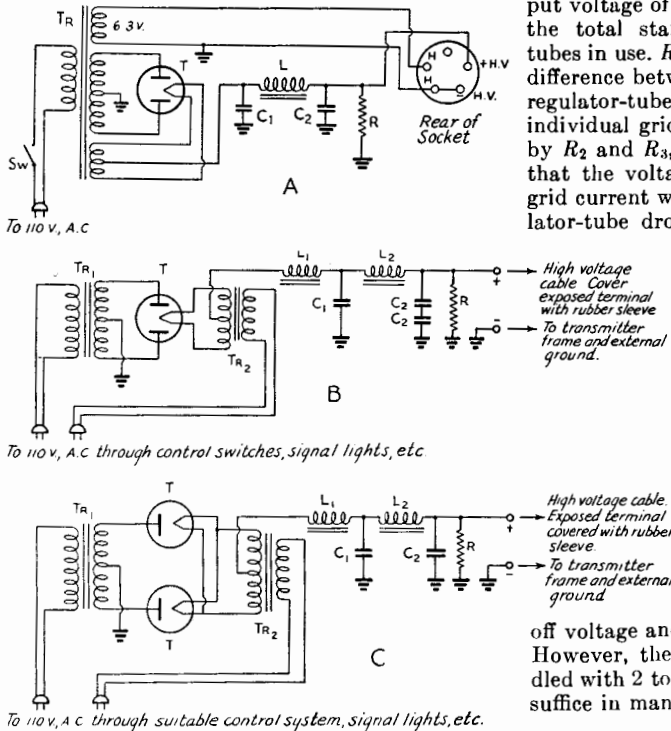

Fig. 1117 — Circuits for power-supply units shown in photographs. References will be found under each photograph where typical values will be found.

Power Supply

with the different classes of service for which power supplies may be used, make it impossible to show complete constructional details of supplies covering every possible need. Throughout this chapter will be found photographs, with lists of typical components, of supplies of the types most commonly used.

The placement of parts is of importance only insofar as it affects the angle of safety to the operator, except in the one or two instances where reference to placement is made.

Referring to the photographs, standard male plugs are set in the rear edges of the chassis for convenience in making connections with standard extension cords. This leaves no exposed live male prongs on the extension cord when disconnected.

In mounting the rectifier sockets, care should be taken to provide plenty of clearance between the filament prongs and grounded metal surfaces. The wiring on the positive side should always be done with specially insulated high-voltage cable. Where the cable must pass through the chassis, the holes should be lined with rubber grommets to prevent chafing. Remember that the rectifier filament wiring should be done with high-voltage cable. When using an exposed high-voltage terminal, such as a feed-through insulator, it should always be covered with a tight fitting rubber sleeve after connection has been made.

Rules for Safe Construction

The following rules, taken from the A.R.R.L. Safety Code should be observed in the construction and installation of power supplies:

Grounds—With chassis construction, all negative terminals of plate-voltage supplies and positive terminals of bias supplies should be connected to chassis *and to a good ground*. Chassis should be connected to-

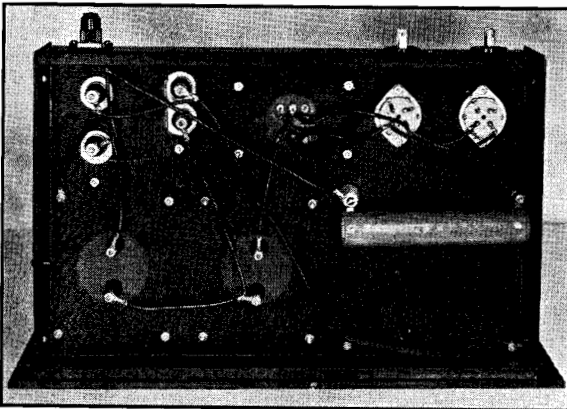

Fig. 1119 — Underneath view of the supply of Fig. 1116 showing cut-outs for sub-terminals.

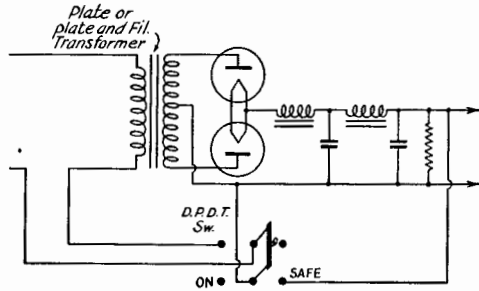

Fig. 1118 — Switch arrangement to discharge filter condensers to guard against possible open bleeder resistance.

gether and to the rack, frame or cabinet, if of metal.

With breadboard construction, negative terminals of plate-voltage supplies and positive terminals of bias supplies should be connected together and to a good ground.

Cases and Cores—Transformer and choke cores, cases and other metal work not normally a part of the electrical circuit should be grounded.

Power Supply Enclosures—Power supplies should be so enclosed or constructed, or so located, that accidental bodily contact with power circuits is impossible when adjustments are being made to r.f. or audio units.

Bleeders—A bleeder resistor should be connected across the d.c. output terminals of each rectified a.c. power supply.

To guard against the very real danger of shock from the discharge of filter condensers should the bleeder resistance burn out without the knowledge of the operator, special relays are now available which short-circuit the output of the filter whenever the primary power is turned off. A switch may be arranged to accomplish the same purpose as shown in Fig. 1118. Should neither of these devices be available, it is always a good idea to attach a metal prod with an insulated handle to the chassis with a wire or chain and run this prod over exposed high-voltage points before touching anything.

H. V. Leads—High-voltage leads should be a good grade of high-tension wire insulated for at least two to three times the peak operating voltage.

The Radio Amateur's Handbook

Terminals — Exposed terminals and tube caps should be protected by insulating coverings. Barriers should be placed over exposed transformer terminal boards

Voltage Dividers

A voltage divider is simply a resistance, connected across the output terminals of a power supply, which has one or more taps at appropriate points from which voltages lower than the power-supply terminal voltage may be obtained. Although quite an improvement over the simple series voltage-dropping resistor, the voltage regulation at the divider taps is, nevertheless, still poor unless its total resistance is made very low, consuming considerable power. It is advisable, therefore, to obtain lower voltages by this method only in cases when the voltage reduction is fairly small or in cases where the load drawn from the taps is fairly constant.

The resistance values required for a voltage divider may be calculated if the currents to be drawn from each tap are definitely known. An example of the calculations follows.

Suppose the voltages desired and the load currents for each tap have been determined as shown in Fig. 1120, i.e., 500 volts, 60 ma. and 350 volts, 30 ma.

To calculate the resistance required between taps, the voltage divider should be laid off in sections, as shown in Fig. 1120. Starting from the negative end, the voltage drop across the first section will be 350 volts. The drop across the second section will be 150 volts, bringing the total voltage between negative and the second tap to 500 volts. The last resistor section will have a drop of 500 volts across it. Then, knowing the current to be drawn at each tap and the idle current to be bled off through the lowest resistor section, it is an easy matter to calculate the resistances required at each section by applying Ohm's Law.

If desired, this voltage-divider may be used as the bleeder resistance. If previous calculations (see section on bleeder resistance) have shown that the required bleeder current is 40 ma., this current value should be used in de-

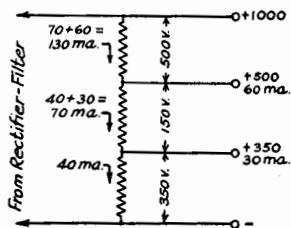

Fig. 1120 — Voltage divider computations can be made by plotting the voltage drops and current division in a diagram similar to this one.

DANGER — HIGH VOLTAGE

IT MUST be realized that the plate supply equipment of even a low-powered transmitter is a potential lethal machine. It is ever ready to deal out sudden death to the careless operator. A number of amateurs, indeed, have been killed by the output of their power supplies during the last few years. Many more have suffered severe injury. We cannot urge too strongly the observance of extreme care in the handling of power supplies and transmitters.

termining the resistance of the first section. The required resistance is, therefore, equal to:

$$\frac{350}{0.04} = 8750 \text{ ohms.}$$

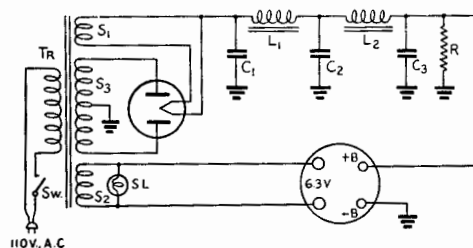

Fig. 1121 — Circuit diagram for receiver power supplies.

Components for 240-volt., 100-ma. unit:

- C₁ — 8- μ fd., 500-volt electrolytic (Mallory HD683)
 - C₂-C₃ — Dual-section 450-volt electrolytic, 40 μ fd. per section. One section used for each filter section. (Mallory FPD238).
 - L₁, L₂ — 15 hys., 100-ma. (UTC R19).
 - R — 15,000 ohms, 10-watt.
 - SL — 6.3-volt signal lamp.
 - Sw — S.p.s.t. toggle switch.
 - T — Type 80 rectifier.
 - Tr — Combination transformer (UTC R12): S₁ — 5 volts, 3 amp. S₂ — 6.3 volts, 4 amp. S₃ — 375 volts, r.m.s. each side of center tap, 100 ma.
- Components for 275-volt, 200-ma. unit:
- C₁ — 4- μ fd., 600-volt electrolytic (Mallory HS691).
 - C₂-C₃ — Dual-section 450-volt electrolytic, 40 μ fd. per section. One section used for each filter section. (Mallory FPD238).
 - L₁, L₂ — 20 hys., 200 ma. (Stancor C1646).
 - R — 20,000 ohms, 10-watt.
 - SL — 6.3-volt signal lamp.
 - Sw — S.p.s.t. toggle switch.
 - T — Type 5Z3 rectifier.
 - Tr — Combination transformer (Stancor P5059): S₁ — 5 volts, 3 amp. S₂ — 6.3 volts, 5 amp. S₃ — 340 volts r.m.s. each side of center tap, 200 ma.

The second section has the 30 ma. for the second tap in addition to the 40 ma. idle current flowing through it, therefore the resistance required is

$$\frac{150}{0.07} = 2150 \text{ ohms (app.).}$$

In the third (upper) section, the current becomes 60 ma. plus the 70 ma. already flowing

Power Supply

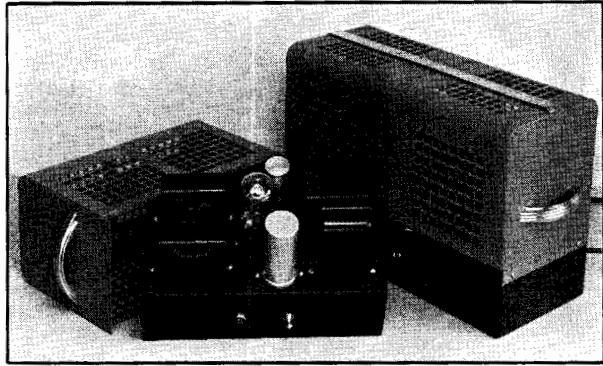

Fig. 1122—Two typical receiver power supplies. The small 100 ma. supply is assembled on a chassis 5 in. by 10 in. by 3 in., while the larger 200-ma. supply is built on a chassis 6 in. by 14 in. by 3 in. The covers protect the equipment against damage and add to the appearance.

through the section below, a total of 130 ma. The resistance value is

$$\frac{500}{0.13} = 3850 \text{ ohms.}$$

The total resistance of the divider is therefore 14,750 ohms, safely below the value necessary to maintain constant output voltage when the tubes are not drawing current from the power supply. This will increase the no-load bleeder current, but will not affect the operation of the power supply under full load. In the above example, the no-load resistor current will be

$$\frac{1000}{14,750} = 63.5 \text{ ma.}$$

Under no-load conditions the voltage across each resistor will be proportional to its individual resistance compared to the total resistance. The drop across the lower section would be

$$\frac{8750}{14,750} \times 1000 = 600 \text{ volts (app.).}$$

The drop across the middle section is

$$\frac{2150}{14,750} \times 1000 = 150 \text{ volts (app.).}$$

Across the upper section

$$\frac{3850}{14,750} \times 1000 = 250 \text{ volts (app.).}$$

The output voltages will be correct only when the load currents used in the calculations are drawn.

The power dissipated by each resistor may be calculated by multiplying the voltage drop across it by the current flowing through it. This should be done for both no-load and full-load conditions, and a resistor selected having a rating well above that of the higher of the two values. It may not be possible to get stock resistors of the exact resistance calculated, in which case the nearest available size usually will be satisfactory. Semi-variable resistors

Fig. 1123—This unit delivers 1500 or 1250 volts at full-load current of 425 ma., with 0.25% ripple and regulation of 10%. Voltages are selected by taps on the secondary. The secondary terminal board is covered with a section of steel panel supported by brackets fastened underneath the core clamps and insulating caps are provided for the tube plate terminals. A special safety terminal (Millen) is used for the positive high-voltage connection. The panel is 10½ in. by 19 in. and the chassis 13 in. by 17 in. by 2 in.

Refer to Circuit C in Fig. 1117

Tr₁—1820–1520 v. r.m.s. each side center, 500 ma. d.c. (Stancor type P6157).

Tr₂—2.5 v., 10 a., 10,000 v. insulation (Stancor type P3025).

T—Type 866.

L₁—5–20 hys., 500 ma., 75 ohms (Stancor C1405).

L₂—8 hys., 500 ma., 75 ohms (Stancor C1415).

C₁, C₂—4 μfds., 2000 v. (C-D type TJU20040).

R—20,000 ohms, 150 watts.

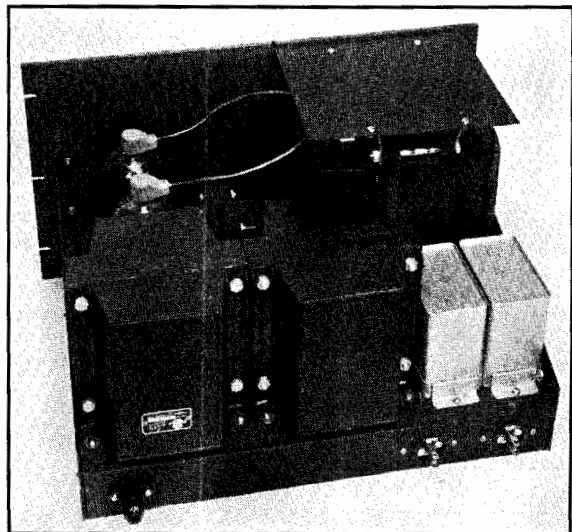

The Radio Amateur's Handbook

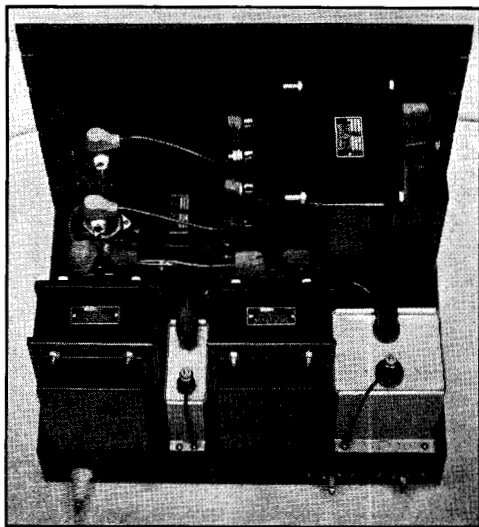

Fig. 1124 — This unit delivers 2025 and 2480 volts at full-load current of 450 ma. with a ripple of 0.5% and regulation of 19%. Voltages are selected by taps on the secondary. All exposed high-voltage terminals are covered with Sprague rubber safety terminal caps and the tube plate terminals with moulded caps. The rectifier tubes are spaced away from the plate transformer to avoid induction troubles. The panel is 14 in. by 19 in. and the chassis 13 in. by 17 in. by 2 in. The exposed high-voltage terminal should be covered with a rubber-tubing sleeve.

Refer to Circuit C, Fig. 1117

Tr₁ — 3000-2450 v. r.m.s. each side of center, 500 ma. d.c. (Thordarson type T19P68).

Tr₂ — 2.5 v., 10 a., 10,000 v. insulation (Thordarson type T64F33).

T — Type 866.

L₁ — 5-20 hys., 500 ma., 75 ohms (Thordarson type T19C38).

L₂ — 12 hys., 500 ma., 75 ohms (Thordarson type T19C45).

C₁ — 1 μ fd., 2500 v. (G.E. Pyranol).

C₂ — 4 μ fds., 2500 v. (G.E. Pyranol).

R — 50,000 ohms, 200 watts.

NOTE. — Regulation may be improved by use of lower bleeder resistance at some sacrifice in maximum load current.

having sliding contacts, so that any desired resistance value may be selected, can be used if more exact adjustment of voltage is required.

In case it is desired to have the bleeder resistance total to a predetermined value — for instance, if the bleeder in the illustration above is to total 25,000 ohms instead of the calculated value of 14,750 ohms — the same method of calculation may be followed, but different values of idle current should be tried until the correct result is found. An idle current of 20

instead of 40 ma., for instance, will work out to a total resistance of approximately 25,000 ohms in the illustration above.

The method may be extended to a greater number of taps, and is equally applicable to the calculation of voltage dividers for receivers.

Receiver Power Supplies

The design of power supplies for receivers is similar to that for transmitters, although the requirements differ somewhat. While the power output is small compared to that required for most transmitters, the degree of filtering required is greater if hum is to be avoided. The high degree of voltage regulation required for high-stability receivers is best obtained by special means, such as the use of voltage-regulator tubes which are usually incorporated in the receiver itself rather than in the power supply. (See Fig. 1111.)

A typical receiver power-supply diagram is shown in Fig. 1121 together with suitable values for 100- and 200-ma. supplies. These units are pictures in Fig. 1122.

Line-Voltage Adjustment

Since the voltage of the line from which the amateur operates his equipment is seldom constant from day to day or day to night, it is often difficult, particularly in small towns or poorly serviced areas, to maintain proper input voltage to the various transformers in the transmitter. While this is usually not of great consequence so far as the plate transformers are concerned, the variation is sometimes great enough to have a serious effect upon the filaments of the tubes, causing short life. Several manufacturers are now producing multi-tapped line transformers which are designed to be placed between the power line and the transformers. By means of the various taps, the secondary voltage of each individual transformer may be set at the proper value. Then, by adjusting the primary tap of the line transformer, all transformers may be corrected simultaneously whenever the line voltage varies appreciably. A small toy step-down transformer delivering 5 to 25 volts may be used for the same purpose by connecting its primary in parallel with the line and its secondary in series with the line. When the secondary is connected in one direction, the transformer voltage will buck the line voltage, while it will add to the line voltage when connected in the opposite direction.

Construction of Modulation Equipment

Speech Amplifiers — Grid and Cathode Modulators — Volume Compression — Class-B Modulators

ALTHOUGH the arrangement of components is less critical in audio than in r.f. equipment, certain principles must be observed to avoid difficulties.

The audio units for small transmitters can be built up bread-board style, but a metal chassis foundation is preferable for a permanent job. Present practice tends toward unit construction on metal chassis, with rack mounting. Shielding is important where high-gain audio systems are used, as it is especially important to keep r.f. from overloading the low-level grid circuits. When two or more stages of speech amplification are used, particular care must be taken to prevent motor-boating and distortion resulting from inter-stage feed-back. Coupling transformers should be isolated from each other or placed for minimum action between their magnetic fields. Proper positions can be determined by turning the transformers, one with respect to the others, until minimum hum or instability is obtained with the unit in operation at full gain. It is advisable to keep modulation chokes and transformers well away from other audio equipment because the strong magnetic field about the high-level audio unit is likely to cause trouble. Transformer cases should be grounded.

Microphone cables should be shielded and the shield should be connected to ground. It is

generally good practice to shield the high-gain input circuit separately and keep it away from the high-level audio and r.f. sections of the transmitter. A speech-input amplifier located some distance from the modulator it drives preferably should be coupled by a step-down transformer (tube-to-line) in its output, through a twisted-pair to a line-to-tube step-up transformer into the higher-level audio circuit. Such an impedance matching combination is especially recommended with high-impedance microphones which require short leads to the first audio stage or pre-amplifier. Interconnecting leads and cables should be thoroughly shielded and the shields grounded. Radio-frequency chokes may be necessary between modulator and modulated amplifier in supply leads.

The term "modulator" is generally reserved for the amplifier stage which actually causes the r.f. output of the modulated amplifier to be varied, and "speech amplifier" for the succession of stages preceding the last. However, the modulator for a low-power transmitter may be the last speech-amplifier stage for the high-power set. For instance, an amplifier may have an audio output of 20 watts; the output could be used to plate-modulate an r.f. amplifier with 40 watts input, or to cathode-modulate an r.f. input depending upon the operating conditions chosen, or to grid-modulate a high-power r.f. amplifier. In all these cases the last stage of the amplifier would be termed the modulator. Alternatively, the amplifier could be used to drive a Class-B audio amplifier for high-power plate modulation, in which case the same stage would be considered part of the speech amplifier. Thus any of the speech-amplifier units to be described may be used as modulators in the different types of service for which they have sufficient audio output, or as drivers for still higher-power Class-B modulators. The only difference in construction is that an output transformer suitable for the purpose must be used in each case.

The units shown in this chapter have been designed to obtain the required output as simply and economically as possible while observing good design principles.

● A SINGLE-TUBE MODULATOR

The modulator (and power supply) pictured in Figs. 1201 and 1203 is about as simple as one

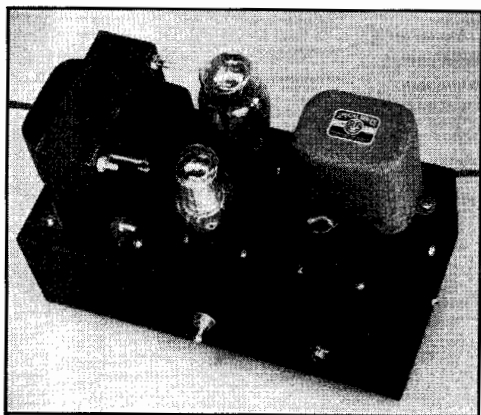

Fig. 1201 — A 4-watt modulator and power supply with provision for regulating the output voltage to be fed to the modulated stage. The switch turns on the plate power and the microphone battery, and the jack is for single-button microphone input.

The Radio Amateur's Handbook

can be made. It is designed especially for use with small u.h.f. transmitters and will deliver up to 4 watts of audio power, which is capable of modulating a transmitter with up to 8 watts input to the modulated stage. As can be seen from the circuit diagram, Fig. 1202, it uses a single-button microphone transformer for coupling the microphone to the grid of the 6F6 modulator tube, and a universal output transformer allows matching the tube to any reasonable load. The proper taps on the transformer can be found from the chart supplied with the output transformer, T_2 . The proper load for the 6F6 is 7000 ohms.

No provision is made for controlling the gain of the modulator, so it must be controlled by the voltage used in the microphone circuit. Usually $1\frac{1}{2}$ volts will be sufficient for up to $1\frac{1}{2}$ watts output with a good microphone, while 3 or $4\frac{1}{2}$ volts may be necessary for full output from the modulator. If the gain is to be decreased below that obtainable with $1\frac{1}{2}$ volts in the

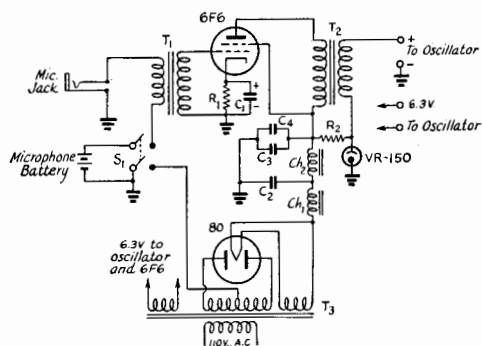

Fig. 1202—A 4-watt modulator and associated power supply.

- C_1 —25- μ fd. 25-volt electrolytic. (Not necessary if adequate gain can be obtained without it.)
- C_2, C_3, C_4 —8- μ fd. 450-volt tubular electrolytic.
- R_1 —350 ohms, $1\frac{1}{2}$ -watt.
- R_2 —3000 ohms, 10-watt wirewound.
- S_1 —D.p.s.t. toggle switch.
- T_1 —S.b. or d.b. microphone to single grid (T-23A57).
- T_2 —Universal modulation transformer, 12 watts (UTC S-18).
- T_3 —700-volt 90-ma. c.t. with 6.3- and 5-volt windings (T-13R13).
- Ch_1 —9-henry 85-ma. choke (T-13C29).
- Ch_2 —15-henry 85-ma. choke (T-68C07).

All transformers and chokes Thordarson except T_2 .

microphone circuit, the cathode condenser, C_1 , can be removed.

The power supply built with the modulator is convenient to use.

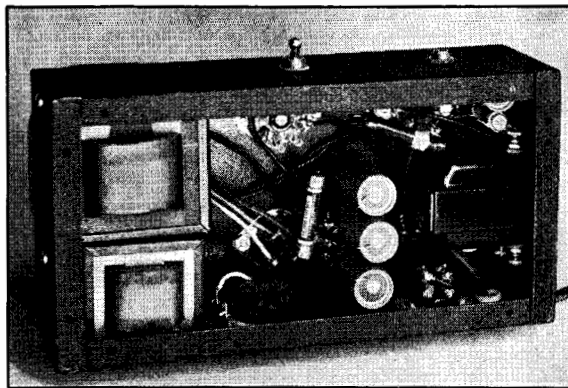

Fig. 1203—This view under the chassis of the modulator and power supply shows how the filter chokes are mounted under the plate transformer and the microphone transformer is mounted under the 6F6 and output transformer. The three filter condensers are mounted upright. A 75,000-ohm 2-watt bleeder resistor (not shown in the diagram) should be connected across the output of the filter (C_3, C_4) if the VR-150 is not used. Wires to the 110-volt line and to the microphone battery are brought out at the rear of the chassis through rubber grommets.

If the stage being modulated takes no more than 8 or 9 watts, its power can be supplied by this unit. If a self-excited oscillator is being used, such as the "pot" oscillator described in Chapter 29, the use of the VR-150 regulator tube gives more stable operation and a steadier carrier. However, its use limits the voltage to 150 on the oscillator, and if a non-regulated supply can be used, the VR-150 tube can be removed from its socket and the resistor R_2 can be shorted.

● ECONOMICAL SPEECH AMPLIFIER AND 3-WATT OUTPUT STAGE

The amplifier of Fig. 1204 is designed for use with crystal and velocity microphones or for carbon single- and double-button microphones, depending upon the circuit chosen. It may be used for grid-modulating r.f. amplifiers of 250 watts input or less. It is also suitable for driving a Class-B modulator whose grid driving power requirements are less than 3 watts.

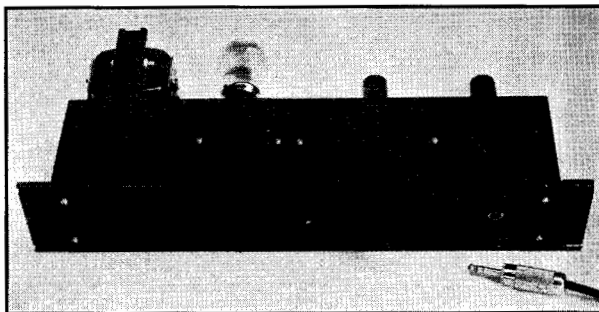

Fig. 1204—Relay-rack mounting amplifier with 3-watt output.

Construction of Modulation Equipment

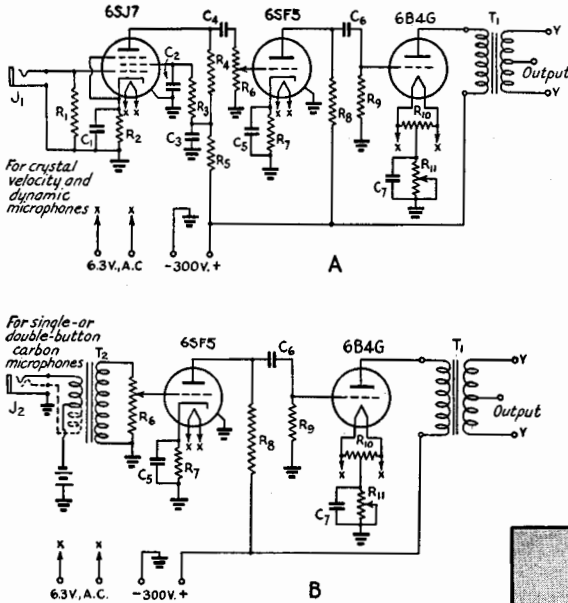

Fig. 1205 — Circuits of the 3-watt speech unit.

- C₁ — 5- μ d. electrolytic, 25-volt.
- C₂ — 0.05- μ d. paper, 600-volt.
- C₃ — 8- μ d. electrolytic, 425-volt.
- C₄ — 0.01- μ d. paper, 600-volt.
- C₅ — 5- μ d. electrolytic, 25-volt.
- C₆ — 0.01- μ d. paper, 600-volt.
- C₇ — 25- μ d. electrolytic, 50-volt wkg.
- R₁ — 5-megohm, 1-watt carbon.
- R₂ — 1700-ohm, 1-watt carbon.
- R₃ — 2.5-megohm, 1-watt carbon.
- R₄ — 0.5-megohm, 1-watt carbon.
- R₅ — 50,000-ohm, 1-watt carbon.
- R₆ — 0.5-megohm potentiometer.
- R₇ — 4500-ohm, 1-watt carbon.
- R₈, R₉ — 0.5-megohm, 1-watt carbon.
- R₁₀ — 50-ohm center-tapped.
- R₁₁ — 800-ohm, 10-watt adj.
- J₁ — 2-wire jack.
- J₂ — 2- or 3-wire jack for s.b. or d.b. mike.
- T₁ — Center-tapped output transformer (Thordarson T-67M74 with primary and secondary reversed, see text).
- T₂ — S.b. or d.b. carbon mike transformer.

The amplifier is constructed on a standard black-crackle chassis 17 inches long, 4 inches deep, and 3 inches high. Tubes and output transformer, instead of being placed in the conventional arrangement on top of the chassis, are mounted on the rear flange, while the front flange is screwed against the back of mounting panel as in ordinary chassis-panel units. With this layout, a 3½-inch relay-rack panel is adequate, and rack-space compactness results.

The grid-modulation output transformer shown is designed to couple the plates of push-pull 2A3 tubes to the grid bias circuit of an r.f. amplifier. In this application, the windings of the transformer are reversed, so that the two-terminal winding is connected in the plate circuit of the 6B4G amplifier tube, and the center-tapped winding is available as an output

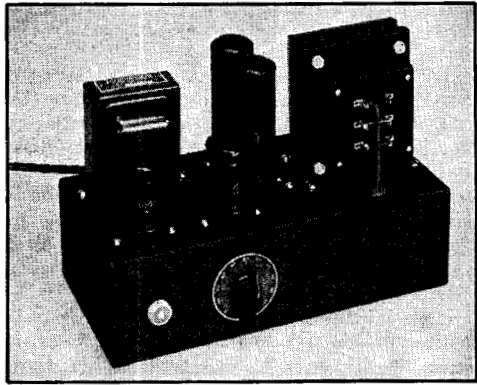

Fig. 1207 — A low-cost speech-amplifier or low-power modulator with a maximum audio output of 20 watts. The 6SJ7 is in the left near corner of the chassis, with the 6J5 to its right, just above the volume control.

winding. Half of this winding (the portion between either end and the center tap) may be connected in an r.f. amplifier grid- or suppressor-bias circuit for modulator use, or the full winding with center tap may be used as a Class-B input winding, with connection direct to the grids of tubes such as 809's or TZ20's.

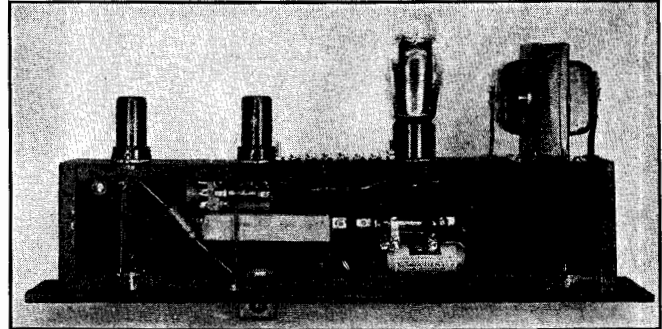

Fig. 1206 — The bottom view shows the tube- and transformer-mounting used in the 3-watt amplifier.

● A 20-WATT SPEECH AMPLIFIER OR MODULATOR

The amplifier shown in Figs. 1207-1209 will deliver audio power outputs up to 20 watts (from the output transformer secondary) with ample gain for ordinary com-

The Radio Amateur's Handbook

munications-type crystal microphones. Class-AB 6L6's are used in the output stage, preceded by a 6J5 and 6SJ7.

The unit is built on a 5 by 10 by 3 inch chassis, with the parts arranged as shown in the photographs. About the only constructional precaution necessary is to keep the lead from the microphone socket (a jack may be used instead of the screw-on type if desired) short, and to shield thoroughly the input circuit to the grid of the 6SJ7. This shielding is necessary to reduce hum. In this amplifier, the 6SJ7 grid resistor, R_1 , is enclosed with the microphone lead in a length of large-size spaghetti tubing which also covers the grid pin on the tube socket. A piece of grounded shield braid is slipped over the spaghetti.

To realize maximum power output, the "B" supply should be capable of delivering about 140 ma. at 360 volts. If an output of 12 or 13 watts will be sufficient, R_9 and R_{10} may be omitted and all tubes fed directly from a "B" supply giving 270 volts at approximately 175 ma.

The output transformer shown is a universal modulation type suitable for coupling into the plate circuit of a low-power r.f. amplifier (input 40 watts maximum for 100 per cent modulation) for plate modulation. For cathode modulation, the r.f. input power that can be modulated may be determined from the data in Chapter 6. The amplifier may also be used for grid-bias modulation with the transformer specified.

If the unit is to be used to drive a Class-B modulator it is recommended that the Class-B tubes be of the zero-bias type rather than types requiring fixed bias. A suitable output

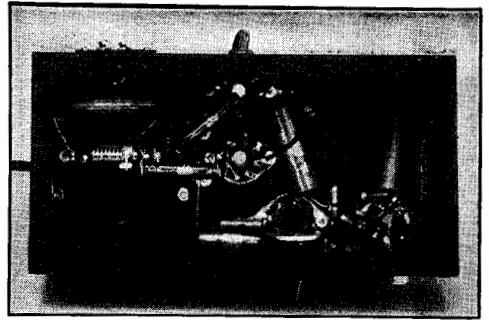

Fig. 1209 — Bottom view of the 20-watt amplifier. The most important constructional point is complete shielding of the microphone input circuit to the grid of the 6SJ7 first amplifier.

transformer must be substituted for this purpose; information may be found in transformer manufacturers' catalogs.

The frequency response of the amplifier is ample for the range of frequencies encountered in voice communication. It may be extended for reproduction of music by using higher-priced audio transformers.

● A 40-WATT OUTPUT SPEECH AMPLIFIER OR MODULATOR

The 40-watt amplifier shown in Figs. 1210–1212 resembles in many respects the 20-watt amplifier just described. To obtain the higher output, however, it is necessary to drive the 6L6's in the grid current region, so that a driver stage capable of furnishing sufficient power is required. A pair of 6J5's in push-pull is used for this purpose, inserted between the 6J5 single stage and the 6L6's. Decoupling is pro-

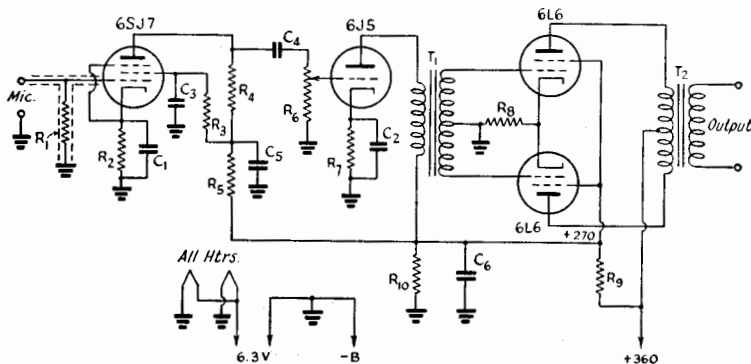

Fig. 1208 — Speech amplifier circuit for power outputs up to 20 watts.

C_1, C_2 — 20- μ fd. electrolytic, 50-volt.
 C_3 — 0.1- μ fd. paper.
 C_4 — 0.01- μ fd. paper.
 C_5, C_6 — 8- μ fd. electrolytic, 450-volt.
 R_1 — 5 megohms, $\frac{1}{2}$ -watt.
 R_2 — 1400 ohms, $\frac{1}{2}$ -watt.

R_3 — 2 megohms, $\frac{1}{2}$ -watt.
 R_4 — 0.5 megohms, $\frac{1}{2}$ -watt.
 R_5 — 50,000 ohms, $\frac{1}{2}$ -watt.
 R_6 — 1-megohm volume control.
 R_7 — 1500 ohms, 1-watt.
 R_8 — 250 ohms, 10-watt.
 R_9 — 2000 ohms, 10-watt.
 R_{10} — 20,000 ohms, 25-watt.

T_1 — Interstage audio, single plate to p.p. grids, ratio 3:1 (Thordarson T-57A41).
 T_2 — Output transformer, depending on requirements. A multi-tap modulation transformer (Thordarson T-19M14) is shown.

Construction of Modulation Equipment

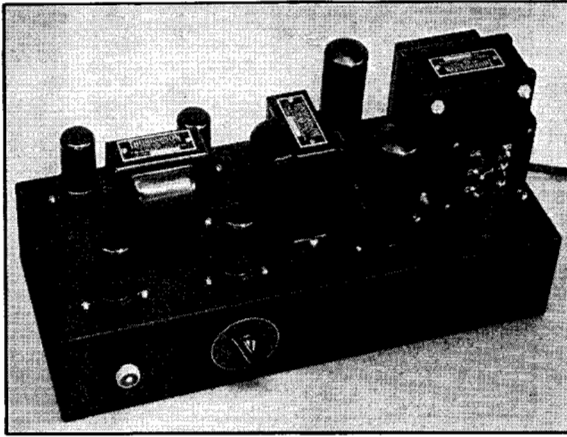

Fig. 1210 — A 40-watt speech amplifier or modulator of inexpensive construction. The 6SJ7 and first 6J5 are at the front, near the microphone socket and volume control, respectively. T₁ is just behind them, and the push-pull 6J5's are at the rear of the chassis behind T₁. T₂, the 6L6's, and T₃ follow in order to the right.

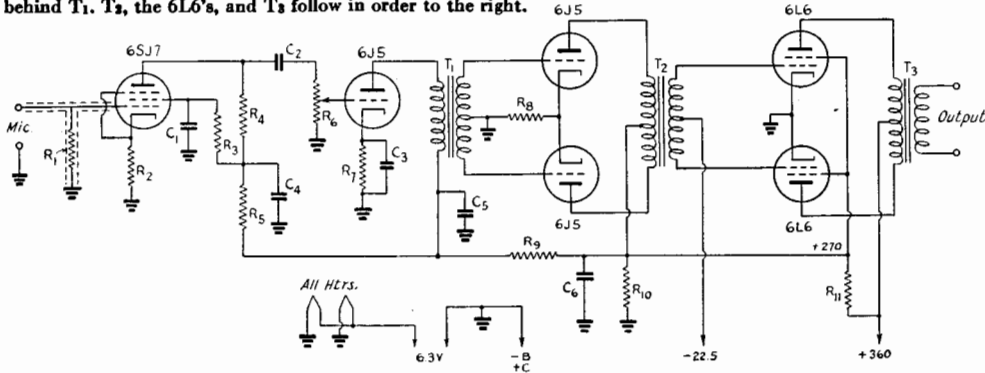

Fig. 1211 — Circuit diagram of the 40-watt speech amplifier-modulator.

- C₁ — 0.1- μ d. paper.
- C₂ — 0.01- μ d. paper.
- C₃ — 20- μ d. electrolytic, 50-volt.
- C₄, C₅, C₆ — 8- μ d. electrolytic, 450-volt.
- R₁ — 5 megohms, $\frac{1}{2}$ -watt.
- R₂ — 500 ohms, $\frac{1}{2}$ -watt.
- R₃ — 0.3 megohm, $\frac{1}{2}$ -watt.
- R₄ — 0.1 megohm, $\frac{1}{2}$ -watt.

- R₅ — 50,000 ohms, $\frac{1}{2}$ -watt.
- R₆ — 1-megohm volume control.
- R₇ — 1500 ohms, 1-watt.
- R₈ — 750 ohms, 1-watt.
- R₉ — 12,000 ohms, 1-watt.
- R₁₀ — 20,000 ohms, 25-watt.
- R₁₁ — 1500 ohms, 10-watt.
- T₁ — Interstage audio, single plate to p.p. grids, 3:1 ratio

- (Thordarson T57A41).
- T₂ — Driver, p.p. 6J5's to 6L6's Class AB2 (Thordarson T84D59).
- T₃ — Output transformer, depending on requirements. A multi-tap modulation transformer (Thordarson T19M15) is shown.

vided (R₉ and C₅) to prevent motorboating because of the higher gain.

A 6 by 14 by 3-inch chassis is used for the 40-watt amplifier. The photographs show the arrangement of parts. As in the case of the 20-watt unit, complete shielding of the microphone input circuit is essential. The am-

Fig. 1212 — Underneath the chassis of the 40-watt amplifier. Shielding of the input circuit is necessary to minimize hum.

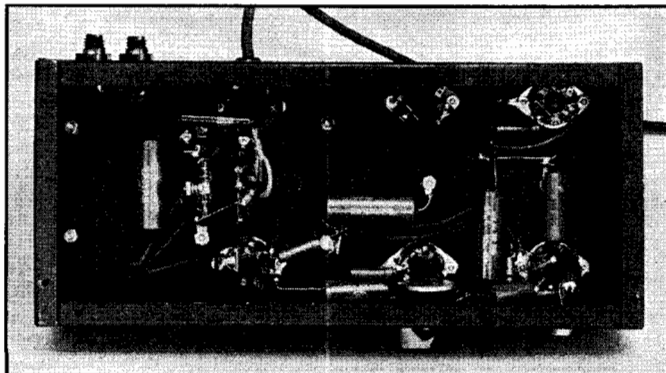

plifier has ample gain for crystal microphones.

This unit may be used to plate-modulate 80 watts input to an r.f. amplifier. For cathode modulation, the input which can be modulated will depend upon the type of operation chosen, as described in Chapter 6; with 55% plate efficiency in the r.f. stage, for instance, the input may be of the order of 200 watts, making an allowance for a small amount of audio power taken by the grid circuit.

A high-power Class-B modulator can be driven by the unit; data on suitable modulator tubes can be found in Chapter 6. Zero-bias tubes should be used because they present a more constant load to the 6L6's than do relatively-low amplification factor tubes which require fixed bias for Class-B

The Radio Amateur's Handbook

operation. A suitable Class-B driver transformer must be substituted for the universal modulation transformer shown.

● A 2A3 SPEECH AMPLIFIER WITH NEGATIVE FEEDBACK

Ideally, a Class-B modulator should be driven by an amplifier having exceptionally good voltage regulation to minimize distortion. The most suitable tubes for such an amplifier are power triodes with low plate resistance such as the 2A3, 6A3, 6B4G and 6A5G. Further reduction in effective plate resistance can be brought about by using negative feedback in the amplifier. For average amateur work the 6L6 amplifiers just described will give satisfactory results, when operated well within their capabilities, especially with zero bias Class-B

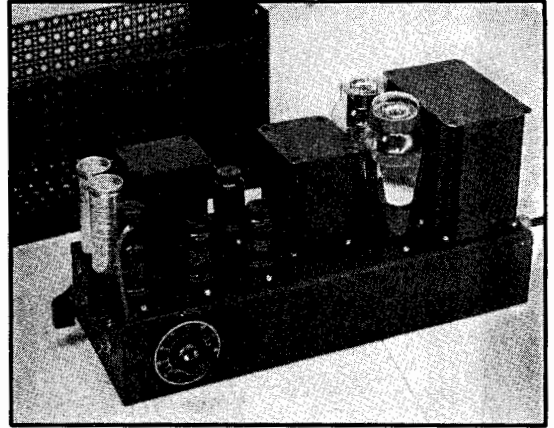

Fig. 1213 — Fifteen-watt speech-amplifier or driver for use with either crystal or double-button carbon microphones.

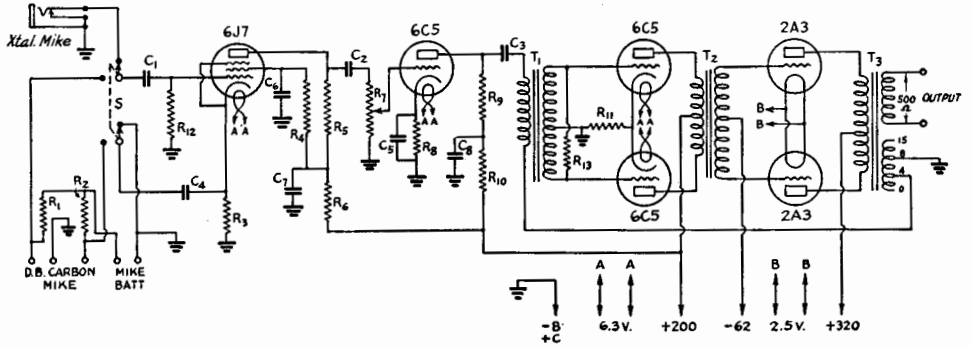

Fig. 1214 — Circuit diagram of the 15-watt speech amplifier.

- | | | |
|--|--|--|
| R_1, R_2 — 200 ohms, $\frac{1}{2}$ -watt. | R_{11} — 500 ohms, 1 watt. | C_7, C_8 — 8- μ fd. electrolytic, 450-volt. |
| R_3 — 1000 ohms, $\frac{1}{2}$ -watt. | R_{12} — 5 megohms, $\frac{1}{2}$ -watt. | T_1 — Interstage audio, single plate to push-pull grids (Kenyon T-52). |
| R_4 — 1 megohm, $\frac{1}{2}$ -watt. | R_{13} — 0.25 megohm, $\frac{1}{2}$ -watt. | T_2 — Interstage audio, p.p. plates to Class-AB grids (Kenyon T-256). |
| R_5 — 0.25 megohm, $\frac{1}{2}$ -watt. | C_1 — 0.1- μ fd. paper. | T_3 — Output, Class-AB plates to line (Kenyon T-301). |
| R_6 — 50,000 ohms, $\frac{1}{2}$ -watt. | C_2 — 0.01- μ fd. paper, 400-volt. | |
| R_7 — 0.25-megohm volume control. | C_3 — 0.1- μ fd. paper, 400-volt. | |
| R_8 — 2000 ohms, $\frac{1}{2}$ -watt. | C_4 — 15- μ fd. electrolytic, 25-volt. | |
| R_9 — 50,000 ohms, 1-watt. | C_5 — 5- μ fd., 25-volt electrolytic. | |
| R_{10} — 10,000 ohms, $\frac{1}{2}$ -watt. | C_6 — 0.1- μ fd. paper, 400-volt. | |

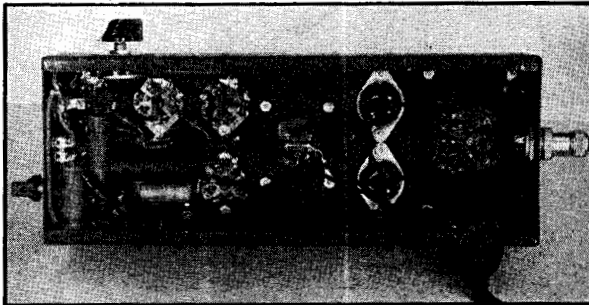

Fig. 1215 — A view underneath the chassis of the 15-watt speech unit.

tubes. However, somewhat lower distortion and higher fidelity can be secured by using an amplifier of the type illustrated in Figs. 1213-1215, which uses push-pull 2A3's in the output stage and incorporates negative feedback in the circuit.

The microphone input circuit is arranged so that either crystal or double-button carbon microphones can be used, and the gain is such that the full output is developed with a peak voltage of less than 0.002 volts applied to the first

Construction of Modulation Equipment

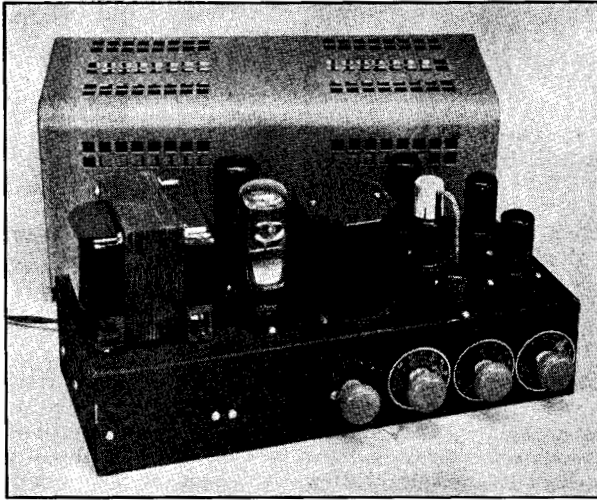

Fig. 1216 — Speech amplifier employing volume compression and audio filter. Controls, left to right, are filter response switch, time delay control, gain control, compressor control.

tube. The circuit diagram is given in Fig. 1214.

The amplifier is built on a standard chassis (with cover) measuring 5 by 13½ by 2½

inches. In Fig. 1213, the tube at the left along the front edge of the chassis is the 6J7, followed by the first 6C5. The single-tube to push-pull transformer, T_1 , is behind this tube; to its right are the push-pull 6C5's, then T_2 , the 2A3's, and the tube-to-line transformer, T_3 . The gain control, R_7 , is at the left end of the front edge of the chassis. On the left edge are the jack for a crystal microphone and the switch, S , to change the input from crystal to double-button carbon.

The general layout of parts underneath the speech-amplifier chassis is shown in Fig. 1215.

For carbon-microphone input, resistors are connected across the microphone as a load, rather than the customary transformer. The high gain of the amplifier permits dispensing with the voltage step-up provided by the microphone transformer. The microphone bat-

tery voltage should be adjusted to give the button current recommended by the manufacturer of the microphone.

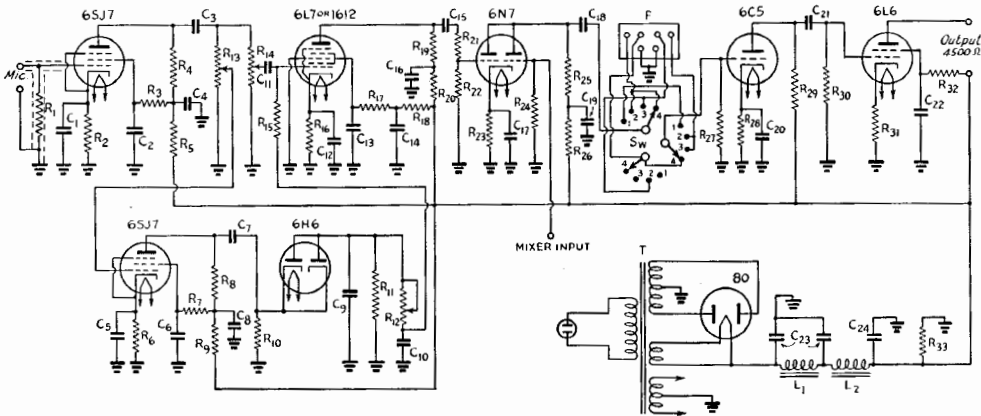

Fig. 1217 — Circuit diagram of speech amplifier with audio filter and compression.

- $C_1, C_6, C_{12}, C_{17}, C_{20}$ — 10- μ fd. 25-volt electrolytic.
- $C_2, C_3, C_5, C_8, C_{18}, C_{21}$ — 0.1- μ fd. 400-volt paper.
- $C_4, C_7, C_{14}, C_{16}, C_{19}, C_{22}$ — 4- μ fd. 350-volt electrolytic.
- C_7, C_{11}, C_{15} — 0.05- μ fd. 400-volt paper.
- C_{10}, C_{13} — 0.25- μ fd. 200-volt paper.
- C_{23} — Dual 8- μ fd. 450-volt electrolytic.
- C_{24} — 4- μ fd. 450-volt electrolytic.
- $R_1, R_7, R_{10}, R_{12}, R_{15}, R_{21}$ — 1-megohm, ½-watt.
- R_2, R_{16} — 1250 ohms, ½-watt.
- R_3 — 2-megohm, ½-watt.

- R_4 — 0.5-megohm, ½-watt.
- R_5, R_9, R_{20}, R_{24} — 40,000 ohms, ½-watt.
- R_6 — 1000 ohms, 1-watt.
- R_8, R_{11} — 0.3-megohm, ½-watt.
- R_{13}, R_{14} — 1.0-megohm potentiometer.
- R_{17}, R_{19} — 0.1-megohm, ½-watt.
- R_{18} — 20,000 ohms, ½-watt.
- R_{22} — 75,000 ohms, ½-watt.
- R_{23} — 1750 ohms, ½-watt.
- R_{25} — 12,000 ohms, 1-watt.
- R_{26} — 13,000 ohms, 1-watt.
- R_{27} — 15,000 ohms, ½-watt.
- R_{28} — 2000 ohms, ½-watt.
- R_{29}, R_{30} — 60,000 ohms, ½-watt.

- R_{31} — 200 ohms, 1-watt.
- R_{32} — 25,000 ohms, 1-watt.
- R_{33} — 60,000 ohms, 10-watt.
- SW — 3-circuit, 4-point switch (Mallory-Yaxley 3234J).
- F — Low-, high- and band-pass audio filter (UTC VT-10).
- T — 700-volt 120-ma. power transformer with 6.3-volt with 3.5 amp. heater winding (Thordarson T-13R14).
- L_1, L_2 — 10-henry, 110-ma. filter chokes (Thordarson T-57C53).

The Radio Amateur's Handbook

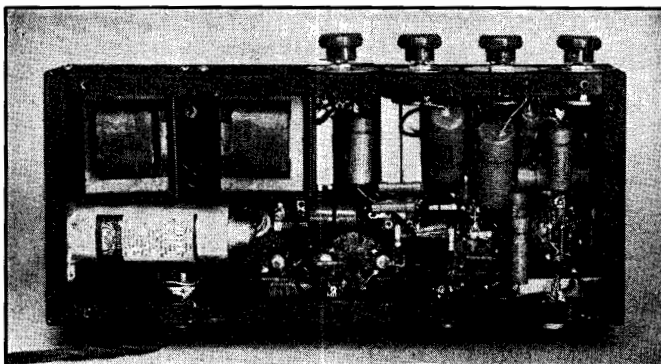

Fig. 1218—Bottom view of amplifier with compressor and filter. Although crowded, components most likely to require replacement or adjustment are reasonably accessible. Plug-in connectors are provided for a.c. supply, output, mixer input, and microphone.

● SIDE-BAND LIMITING AND COMPRESSION

In voice work it is not only necessary that the signal be reasonably strong at the receiving point, but its modulation must be intelligible. Maximum efficiency in terms of intelligibility can be achieved by a high *average* modulation level and by concentrating the speech energy in those frequencies which contribute most to articulation.

The average modulation level can be increased without objectionable overmodulation by giving the amplifier a gain characteristic such that the modulation percentage is higher than normal for low inputs and flattens off for peaks. This is accomplished by using a side amplifier and diode rectifier, the varying d.c. output of which is used to bias a remote cut-off pentagrid amplifier, thus changing its gain in inverse proportion to the input signal strength.

Concentration of speech energy for most efficient transmission can be accomplished by the use of low-, high- and band-pass a.f. filters. The frequencies below about 300 cycles have a larger proportionate energy content than those above, yet do not contribute appreciably to *intelligibility* (not to be confused with *naturalness*). Their elimination allows more energy to be used for the remaining frequencies before overmodulation occurs. Hum is also reduced. Elimination of frequencies above about 3000 cycles takes out hiss and sibilants, as well as improving the energy content somewhat, and reduces side-band splatter and general interference. Since these frequencies are seldom passed by the ordinary communications receiver, little is lost in the way of quality.

Actual tests indicate that, with the use of a suitable band-pass filter, it is possible to get good intelligibility under interference conditions such that less than 10 per cent intelligibility is reported when full frequency response is used.

Figs. 1216–1218 show a speech amplifier in which the use of a band-pass filter and compression circuit give a several-times increase

in the average effective power of the transmitter with which it is used.

The customary high-gain pentode input stage is followed by a 6L7 (or the non-microphonic 1612) which is used as the variable-gain amplifier. D.c. voltage from the 6SJ7-6H6 side amplifier and rectifier combination biases the 6L7 increasingly negative as the signal rises, reducing its gain. The degree of compression is controlled by R_{13} ; it is independent of the actual gain control, R_{14} .

The use of an oscilloscope in adjusting the compressor is strongly advised, in order to avoid operation in regions where distortion occurs. Gain and compression controls should be adjusted simultaneously until maximum limiting occurs at the 100 per cent modulation point with full input. The time-delay control, R_{12} , can then be adjusted to give the smallest delay possible without introducing distortion.

Following the 6L7 is a 6N7, which serves both as a mixer and as input to the audio filter. The mixer channel can be connected to the receiver output or other signal source for retransmission or separate pick-up, as desired. The filter is connected into the circuit by means of a 4-point switch, with the following positions: 1, low-pass; 2, high-pass; 3, band-pass; 4, full-pass. Thus the transmitter quality can be adjusted to the transmission conditions encountered.

As shown, a 6C5 is used to drive a single 6L6. The 6L6 cathode resistor is unby-passed to make the amplifier slightly degenerative. This arrangement provides a power output of about 6.5 watts with reasonably-low distortion, or enough to drive the average modulator of 100–250 audio watts capability. Alternatively, the 6C5 could be operated into a tube-to-line transformer to supply push-pull 2A3's or 6L6's as drivers in a separate driver-modulator combination.

● CLASS-B MODULATORS

Class-B modulator circuits are practically identical no matter what the power output of

Construction of Modulation Equipment

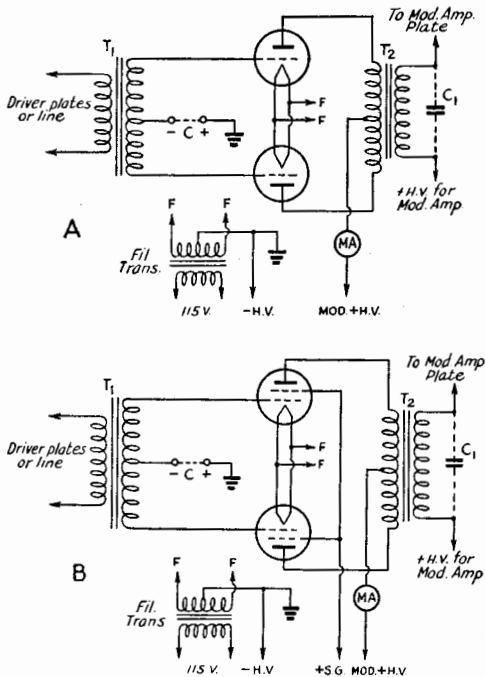

Fig. 1219 — Class-B modulator circuit diagrams. Circuit considerations are discussed in the text.

the modulator. The diagrams of Fig. 1219 therefore will serve for any modulator of this type that the amateur may elect to build. The triode circuit is given at A, and the circuit for tetrodes at B. When small tubes with in-

directly heated cathodes are used, the cathode should be connected to ground.

Design considerations for Class-B stages are discussed in Chapter 6, and data on the performance of various tubes suitable for the purpose also will be found in that chapter. Once the requisite audio power output has been determined, and the pair of tubes capable of giving that output selected, an output transformer may be secured which will permit matching the rated modulator load impedance to the modulating impedance of the r.f. amplifier, and similarly, a driver transformer selected which will couple the driver stage to the Class-B grids properly.

The plate power supply for the modulator should have good voltage regulation and should be well filtered. It is particularly important, in the case of a tetrode Class-B stage, that the screen supply have excellent regulation to prevent distortion. The screen voltage should be set as exactly as possible to the recommended value.

In estimating the output of the modulator, it should be remembered that the figures given in the tables of Chapter 6 are tube output only, and do not include output transformer losses. The efficiency of the output transformer will vary with its construction, and may be assumed to be in the vicinity of 80 per cent for the less expensive units and somewhat higher for higher-priced transformers. To be adequate for modulating the transmitter, therefore, the modulator should have a theoretical power capability about 25 per cent greater than the actual power needed for modulation.

Fig. 1220 — Chassis-less construction for a low-power Class-B modulator. Small tubes and transformers capable of an audio output of the order of 100 watts may be supported directly from the panel.

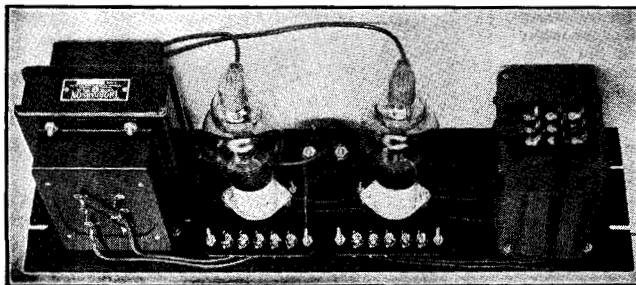
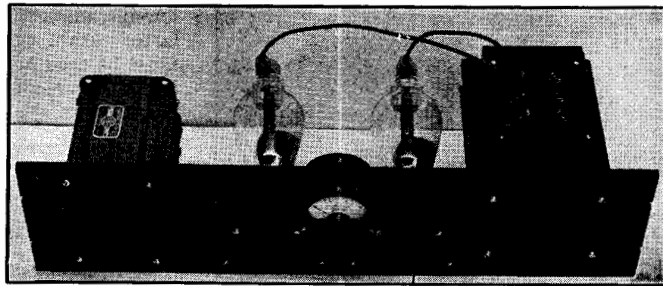

Fig. 1221 — A rear view of the modulator of Fig. 1220, showing how the components are supported. The panel is relay-rack size, $5\frac{1}{4}$ inches high.

The Radio Amateur's Handbook

Fig. 1222 — A conventional chassis arrangement for low and medium power Class-B modulators. The layout follows the circuit diagram. In building modulation equipment the safety considerations discussed in connection with transmitters and power supplies (Chapters 10 and 11) should be observed. Feed-through terminals such as those shown should be covered by a guard plate or by rubber sleeves when the modulator is installed in the rack so that no high-voltage parts are exposed. Safety screw-on terminals may be used instead.

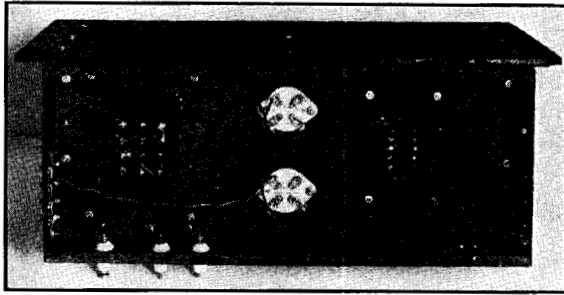
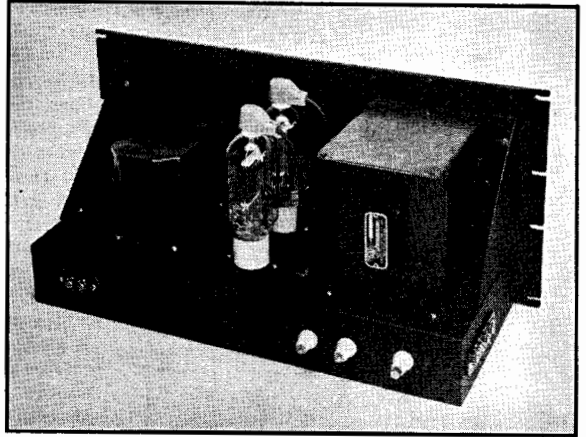

Fig. 1223 — The simplicity of modulator wiring is evident in this view of the bottom of the chassis of the modulator unit shown in *Fig. 1222*.

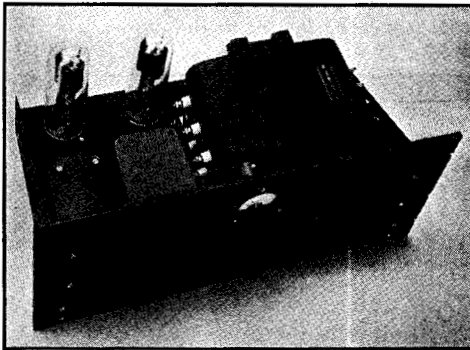

Fig. 1224 — A chassis arrangement for a higher-power Class-B modulator. This unit has a filament transformer for the tubes mounted on the chassis, as well as the input and output transformers. In cases where the input transformer is included with the speech amplifier, less chassis space is needed. The tubes are placed to the rear where ventilation is good.

The plate milliammeter is provided with a small plate over the adjusting screw to prevent touching the screw accidentally. A Presdwood panel was used for this modulator; with metal panels the meter should be mounted behind glass on a well-insulated mount (the meter insulation is not intended for voltages greater than a few hundred) or else should be connected in the filament center-tap rather than in the positive high-voltage lead.

The input transformer, T_1 , may couple directly between the driver tube and the modulator grids or may be designed to work from a low-impedance (200- or 500-ohm) line. In the latter case a tube-to-line output transformer must be used at the driver stage. This type of coupling is recommended only when the driver must be at a considerable distance from the

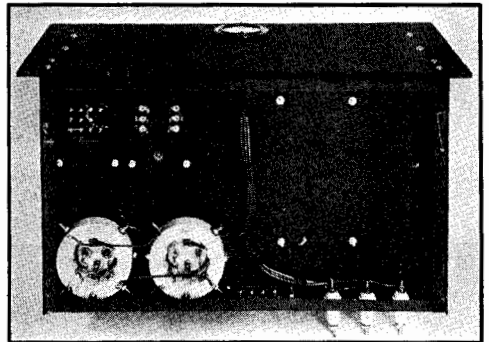

Fig. 1225 — Bottom view of the modulator of *Fig. 1224*. Mounting the sockets below the chassis saves panel height and conceals the wiring. The output terminals should be protected as described in connection with *Fig. 1222*.

Construction of Modulation Equipment

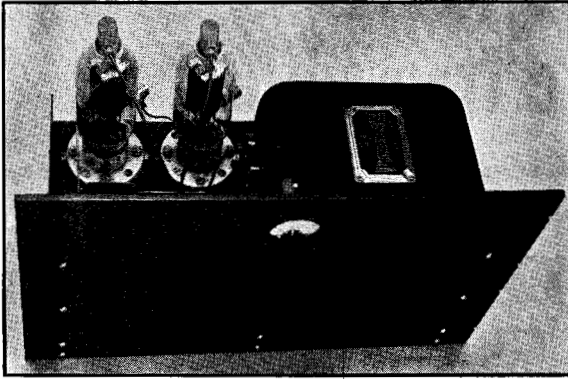

Fig. 1226 — With high-power modulators, components become so large that chassis space is at a premium in relay-rack construction. There is, however, room for either the input transformer or a filament transformer on the chassis. See Fig. 1224 for discussion of meter mounting.

modulator, however, because the second transformer not only introduces additional losses but also further impairs the voltage regulation.

When "C" bias is required for the modulator, the bias source must have very low resistance. Batteries are the most suitable source of bias. In cases where the voltage values are right, regulator tubes such as the VR-75, VR-105, etc., may be connected across a tap on an a.c. bias supply and will hold the bias voltage steady under grid-current conditions. Generally, however, zero-bias tubes are preferable not only because no bias supply is required but also because the loading on the driver stage is

less variable and driver distortion is consequently reduced.

Condenser C_1 in these diagrams will give a "tone-control" effect and filter off high-frequency side-bands (splatter) caused by distortion in the modulator or preceding speech-amplifier stages. Values in the neighborhood of 0.002 to 0.005 μ d. are suitable. The voltage rating should be adequate for the peak voltage across the transformer secondary. The plate by-pass condenser in the modulated amplifier will serve the same purpose.

The various photographs illustrate different types of construction which may be used for Class-B modulators of various power outputs. Placement of parts is not critical.

Complete Transmitters

Rack Construction — Metering — Assembly of Constructed Units to Form Complete Transmitters for 'Phone or C.W.

MOST of the units described in the constructional chapters of this handbook are designed for standard rack mounting and, therefore, the assembly of a selected group of units to form a complete transmitter is a relatively simple matter. While standard metal racks are available on the market, many amateurs prefer to build their own from less expensive wood stock. With a little care, an excellent substitute can be made.

The plan of a rack of standard dimensions is shown in Fig. 1301. The rack is constructed entirely of 1" X 2" stock of smooth pine, spruce or redwood, with the exception of the trimming strips, *M*, *N*, *O* and *P*. Since the actual size of standard 1" X 2" stock runs appreciably below these dimensions, a much sturdier job will result if pieces are obtained cut to the full dimensions.

The two main vertical supporting members are each comprised of two pieces (*A* and *B*, and *I* and *J*) fastened together at right angles. Each pair of pieces is fastened together by No. 8 flat head screws, countersunk.

Before fastening these pairs together, pieces *A* and *J* should be made exactly the same length and drilled in the proper places for the mounting screws using a No. 30 drill. The length of pieces *A*, *J*, *B* and *I* should equal the total height of all panels required for the

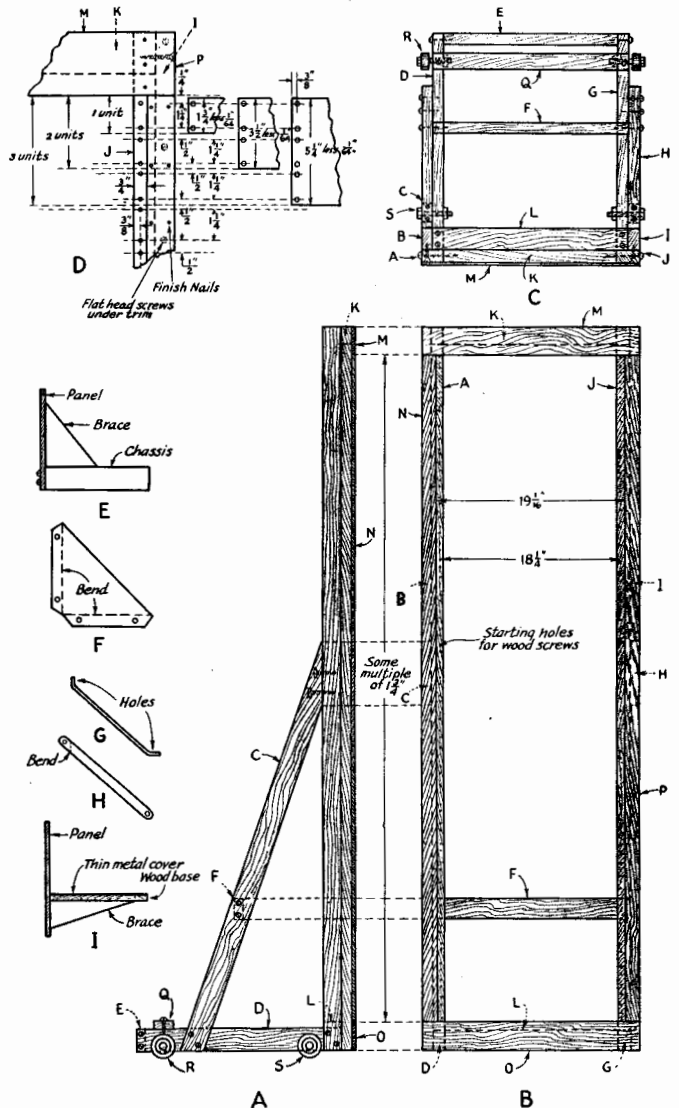

Fig. 1301 — The standard rack. A — Side view, B — front view, C — Top view, D — Upper right hand corner detail, E — Panel and chassis assembly, F, G, H — Various types of panel brackets, I — A substitute for the metal chassis.

Complete Transmitters

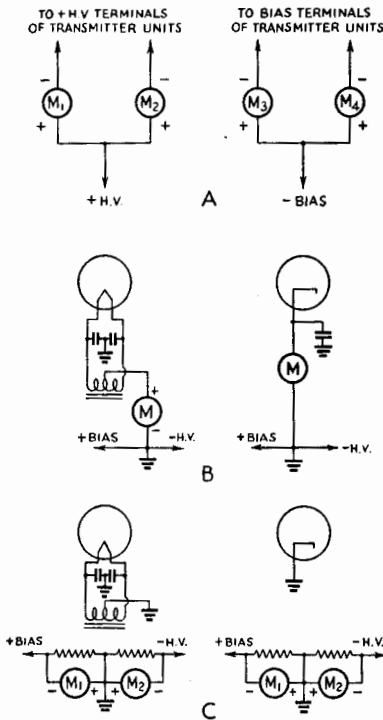

Fig. 1302 — Various methods of metering grid and plate currents. A — High-voltage metering. B — Cathode metering. C — Shunt metering.

transmitter plus *twice* the sum of the thickness and width of the material used. If the dimensions of the stock are exactly $1'' \times 2''$, then $6''$ must be added to the sum of the panel heights. An inspection of the top and bottom of the rack in the drawing will reveal the reason for this. The first mounting hole should come at a distance of $\frac{1}{4}''$ plus the sum of the thickness and width of the material from either end of pieces A and J. This distance will be $3\frac{1}{4}''$ for stock exactly $1'' \times 2''$. The second hole will

come $1\frac{1}{4}''$ from the first, the third $\frac{1}{2}''$ from the second, the fourth $1\frac{1}{4}''$ from the third and so on, alternating spacings between $\frac{1}{2}''$ and $1\frac{1}{4}''$ (see detail drawing D, Fig. 1301). All holes should be placed $\frac{3}{8}''$ from the inside edges of the vertical members.

The two vertical members are fastened together by cross-member K at the top and L at the bottom. These should be of such a length that the inside edges of A and J are exactly

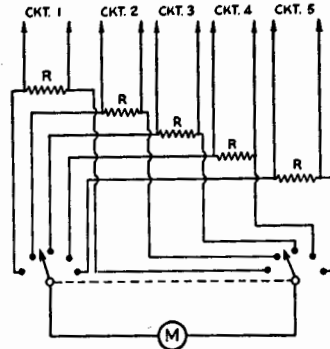

Fig. 1304 — Method of switching a milliammeter to various circuits with a two-gang switch. The control shaft should be well insulated from the contacts and grounded. The resistances should be ten to twenty times the resistance of the meter; 20 ohms will usually be satisfactory.

$17\frac{1}{2}''$ apart at all points. This will bring the lines of mounting holes $18\frac{1}{4}''$ center to center. Extending back from the bottoms of the vertical members are pieces G and D connected together by cross-members L, Q and E, forming the base. The length of the pieces D and G will depend upon space requirements of the largest power supply unit which will rest upon it. The vertical members are braced against the base by diagonal members C and H. Rear support for heavy units placed above the base may be provided by mounting angles on the in-

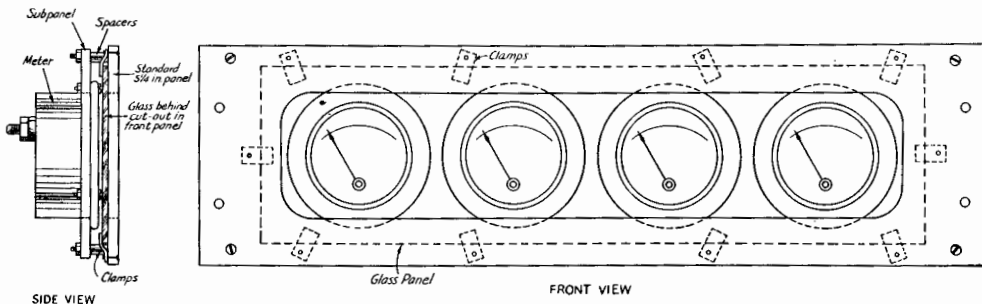

Fig. 1303 — Safety panel for meters. The meters are mounted in the usual manner on an insulating sub-panel spaced back of a glass-covered opening in the front panel. The glass is fastened in place with metal clamps or tabs fastened to the front panel with small screws or pins. The front panel is of standard size 19 in. by $5\frac{1}{4}''$.

The Radio Amateur's Handbook

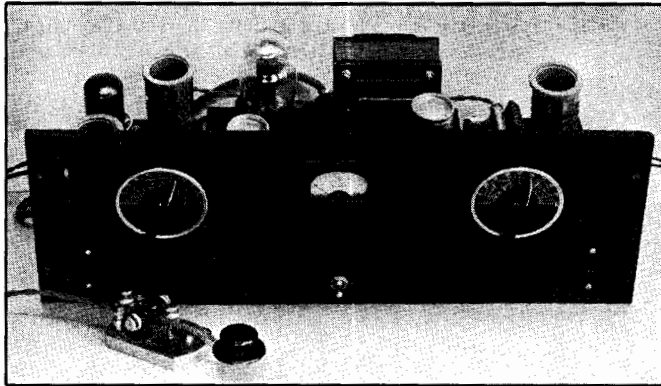

Fig. 1305 — Low-power c.w. transmitter made up from the units shown in Figs. 1003, 1046 and 1102. The panel is of standard rack size, 7 in. high by 19 in. long. The meter has a range of 200 ma. The three chassis are bolted together with machine screws and the two outside units are then fastened to the panel. Fig. 1306 shows the slight alterations which are required in the power supply. The link-output terminals of the oscillator are connected to the link-input terminals of the antenna-tuner unit by a pair of closely-spaced wires.

Fig. 1306 — Diagram showing alterations in connections in power-supply unit of Fig. 1102 for the low-power c.w. transmitter of Fig. 1305. A 50-watt, 15,000-ohm resistor, R_1 , with slider replaces R . The connection to the negative high-voltage prong is removed and the positive side of the meter connected to this prong. The negative side of the meter is connected to the chassis. The slider on the voltage divider connects to the vacant prong of the power output socket, thereby supplying screen voltage for the 6L6.

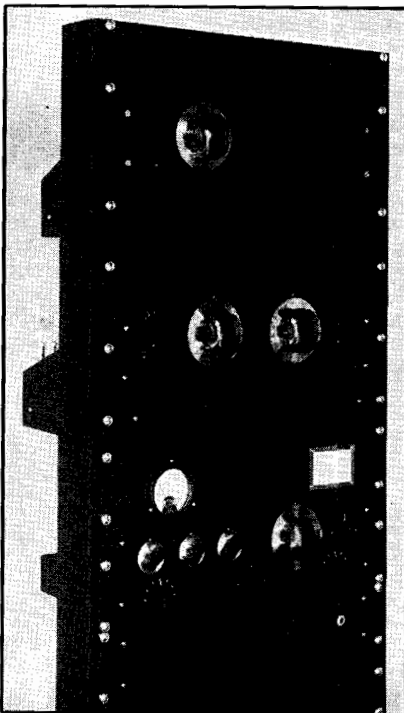
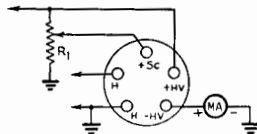

Fig. 1307 — A 450-watt hand-switching transmitter with grid modulator included for 150-watt 'phone. Complete layout shown in Fig. 1308.

sides of C and H , or by connecting them with cross-members at suitable heights as shown at F .

To finish off the front of the rack pieces of $\frac{1}{4}$ " oak strip (M, N, O, P) are fastened around the edges with small-head finishing nails. The heads are set below the surface and the holes plugged with putty or plastic wood. They should be of such a width that the top and bottom edges of O and P respectively should be $\frac{1}{4}$ " from the first mounting holes and the distance between the inside edges of the vertical strips, N and P , $19\frac{1}{6}$ ".

To prevent the screw holes from wearing out when panels are changed frequently, $\frac{1}{2}$ " \times $\frac{1}{16}$ " or $\frac{3}{32}$ " thick iron or brass strip may be used to back up the vertical members of the frame.

The outside surfaces should be sandpapered thoroughly and given one or two coats of flat black finish, sandpapering between coats. A finishing surface of two coats of glossy black "Duco" is then applied, again sandpapering between coats. It is important to allow each coat to dry thoroughly before applying the next, or sandpapering.

Since the combined weights of power supplies, modulator equipment, etc., may total to a surprising figure, the rack should be provided with rollers or wheels so that it may be moved about when necessary after the transmitter has been assembled. For this purpose, ball bearing roller-skate wheels are excellent.

Standard chassis are 17 inches wide. Standard panels are 19 inches wide and multiples of $1\frac{3}{4}$ inches high. Panel mounting holes start with the first one at $\frac{1}{4}$ -inch from the edge of the panel, the second $1\frac{1}{4}$ inches from the first, the third $\frac{1}{2}$ -inch from the second, the fourth $1\frac{1}{4}$ inches from the third and the distances between holes from there on alternate between $\frac{1}{2}$ -inch and $1\frac{1}{4}$ inches. (See detail D , Fig. 1301.) In a panel higher than two or three rack units ($1\frac{3}{4}$ in.), it is common practice to drill only sufficient holes to provide a secure mounting.

Complete Transmitters

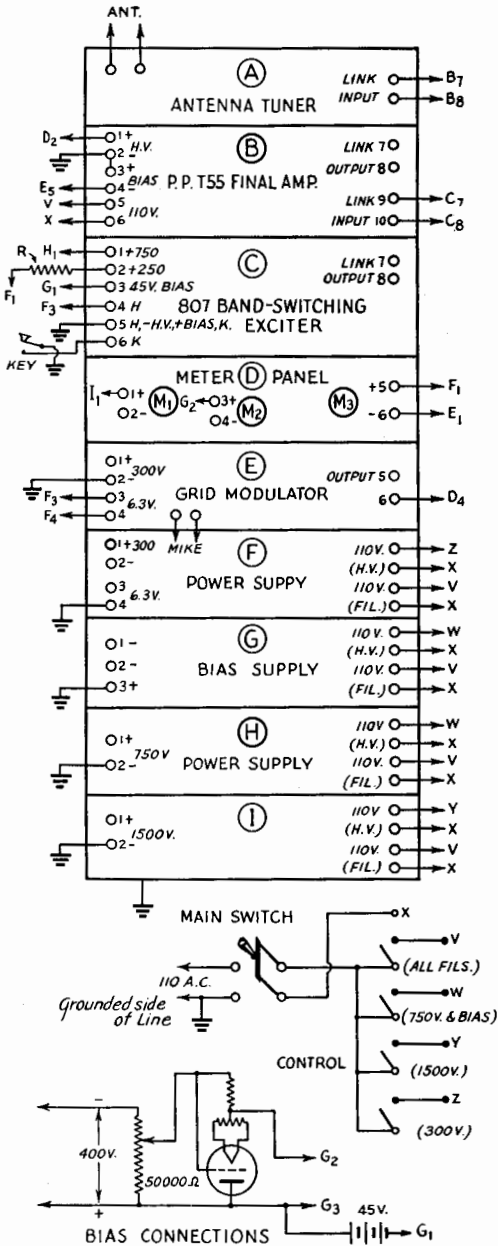

Fig. 1308 — Complete layout of grid-modulated phone-c.w. transmitter.

- A — Antenna tuner (Fig. 1052).
- B — Band-switching p.p. T55 final amplifier (Fig. 1039).
- C — Band-switching 807 exciter (Fig. 1022).
R — Adjustable dropping resistor to drop 300 volts to 250 volts for exciter.
- D — Meter panel. M₁ — for final-amplifier plate current, 0–500 ma.
M₂ — For final-amplifier grid current, 0–150 ma.
M₃ — For modulator plate current, 0–150 ma.
- E — Grid modulator (Fig. 1205). Half of output transformer output winding used (see text referring to Fig. 1205). For loading of final grid circuit see Chap. 16.
- F — Power-supply for modulator, 6.3-volt, 4-amp. filament transformer for modulator and exciter.

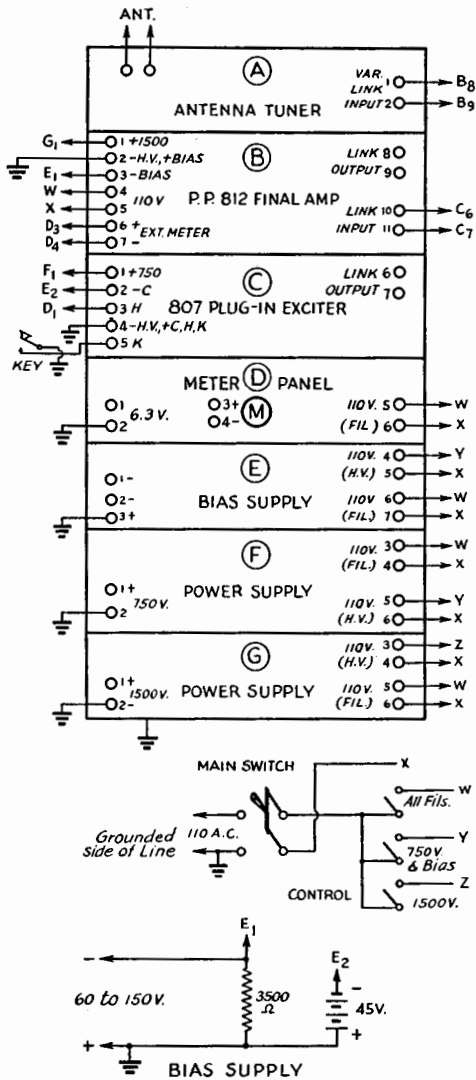

Fig. 1309 — Complete layout for 450-watt c.w. transmitter.

- A — Wide-range antenna coupler (Fig. 1052).
- B — P.p. 812 final amplifier (Fig. 1034). Remove grid leaks R and R₁.
- C — Plug-in 807 exciter unit (Fig. 1018).
- D — Meter panel, M — reading final-amplifier grid and plate currents, 0–100 ma. (See text referring to Fig. 1034 regarding shunts.) 6-volt, 3-amp. filament transformer mounted on sub-panel to supply exciter heaters.
- E — Bias supply (Fig. 1112). Adjustment shown in detail. This unit also contains 45-volt battery for 807 bias.
- F — 750-volt plate supply for exciter (Fig. 1110).
- G — 1500-volt plate supply for final amplifier (Fig. 1123).
- G — Bias supply for exciter and final amplifier (Fig. 1113). Connections shown in detail. Unit also contains 45-volt battery for 807 bias.
- H — 750-volt supply for exciter (Fig. 1110).
- I — 1500-volt supply for final amplifier (Fig. 1123).

The Radio Amateur's Handbook

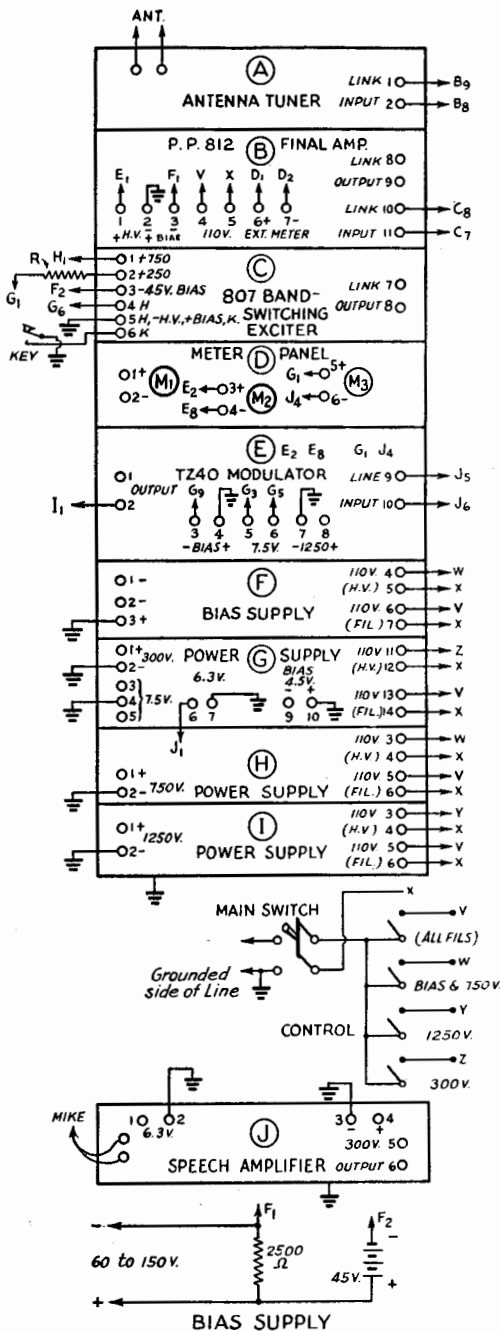

Fig. 1310 — Layout for 300-watt 'phone-c.w. transmitter.

- A — Antenna tuner (Fig. 1049).
- B — Push-pull final amplifier, 812's (Fig. 1034) operated at 1250 volts, 250 ma. Remove grid leaks R and R₁.
- C — Band-switching 807 exciter (Fig. 1018).
- D — Meter panel. M₁ — 0–100 ma. for final-amplifier

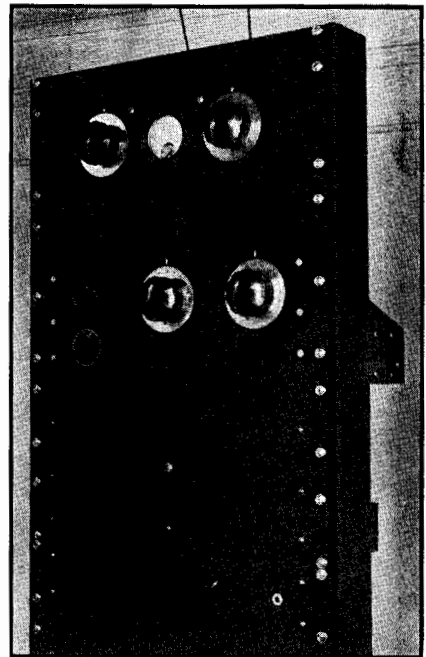

Fig. 1311 — 200–250-watt transmitter for c.w. or plate-modulated phone. Rear view shown in Fig. 1313 and complete layout in Fig. 1312.

All panel holes should come $\frac{3}{8}$ -inch from each edge.

Metering

Various methods of metering are shown in Fig. 1302. A shows the meters placed in the high-voltage plate and bias circuits. M₁ and M₂ are for plate current and M₃ and M₄ for grid current. When more than one stage operates from the same plate-voltage or bias-voltage supply, each stage may be metered as shown. If this system of metering is used, the meters should be mounted so that the meter dials are not accessible to accidental contact with the adjusting screw. One method of

- grid and plate currents. (See text referring to Fig. 1034 regarding shunts.)
- M₂ — 0–300 ma. for modulator plate current.
- M₃ — 0–100 ma. for speech amplifier.
- E — TZ40 modulator (Fig. 1222) operated at 1250 volts, 4.5-volts bias. Set output transformer for 14,000 to 5000 ohms.
- F — Bias supply (Fig. 1112). Adjustment shown in detail. This unit also contains 45-volt battery for 807 bias.
- G — Power-supply unit containing 300-volt, 200-ma. plate supply for speech amplifier and exciter; 6.3-volt, 4-amp. and 7.5-volt, 5-amp. filament transformers for speech-amplifier and modulator filaments.
- H — 750-volt plate supply for exciter (Fig. 1110).
- I — 1250-volt plate supply for final amplifier and modulator (Fig. 1116).
- J — Speech amplifier (Fig. 1204), 2500-ohm-to-line transformer substituted for T₁.

Complete Transmitters

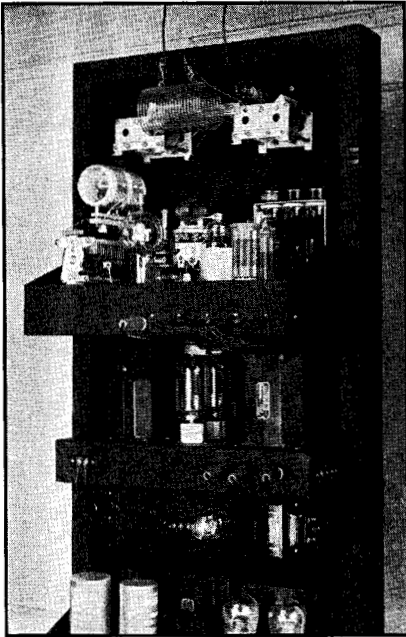

Fig. 1313 — Rear view of 200-watt plate-modulated transmitter showing antenna coupler, r.f. unit, modulator and speech amplifier.

mounting is shown in Fig. 1303 where the meters are mounted behind a glass panel.

When plate milliammeters are to be mounted on metal panels, care must be taken to see that the insulation is sufficient to withstand the plate voltage. Metal case instruments should not be mounted on a grounded metal panel if the difference in potential between the meter and panel is more than 300 volts; instruments with bakelite cases can be used under similar circumstances at voltages up to 1000. At higher voltages an insulating panel should be used.

The placing of meters at high-voltage points in the circuit may be overcome by the use of connections shown in Fig. 1302-A and -B. The disadvantage of the arrangements of B is that the meter reads total cathode current and grid and plate currents cannot be metered indi-

Fig. 1312 — Complete layout for 200- to 250-watt transmitter with plate modulation.

- A — Antenna coupler (Fig. 1049).
- B — R.F. unit, 6V6-807-75T (Fig. 1029). Final operated at 1250 v., 175 ma. Cathode keying of 807 shown.
- C — Meter panel. M_1 — 0-150 ma. on 3-pt., double-gang switch for exciter-cathode and final-grid currents. Shunt resistors in detail 20 ohms. M_2 — 0-400 or 500 ma. for final-amplifier cathode current. M_3 — 0-300 ma. on 2-pt., double-gang switch for modulator and speech-amplifier plate currents. Shunts 20 ohms. Switch must be insulated for high voltage.

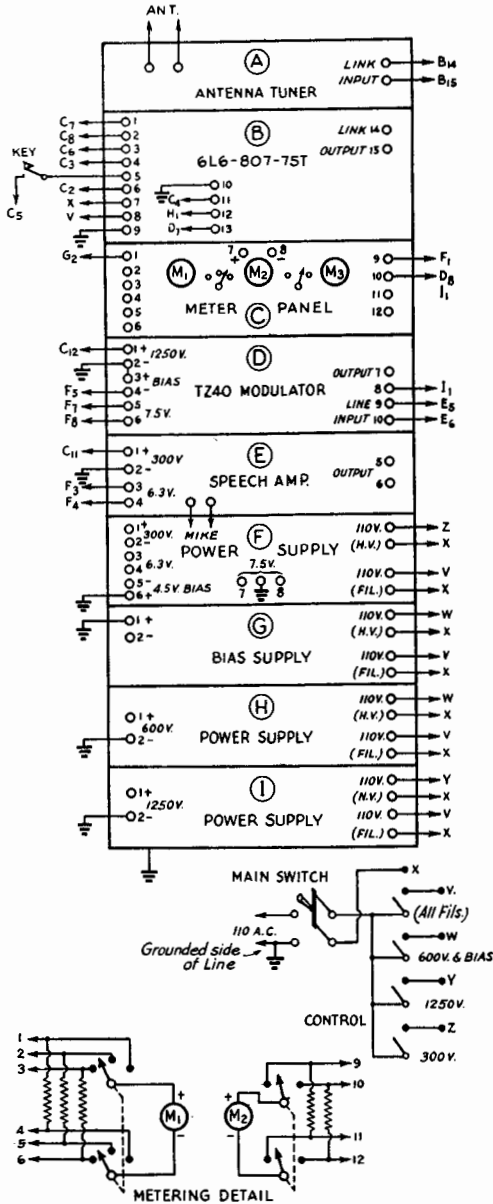

- D — Modulator (Fig. 1222). TZ40's operating at 1250 v. plate and 4.5 v. bias. Output transformer set for 14,000 to 7200 ohms.
- E — Speech amplifier (Fig. 1204) with 2500-ohm to line output transformer substituted for T_1 .
- F — Power-supply unit containing 300-v., 100-ma. plate supply for speech amplifier, 6.3-v., 3-a. and 7.5-v., 5-a. filament transformers for speech and modulator units and 4.5-v. battery for modulator bias.
- G — Bias supply for final amplifier. 150 to 300-v. supply with 10,000-ohm bleeder.
- H — 600-v. plate supply for 807 (Fig. 1110).
- I — 1250-v. plate supply for modulator and final amplifier (Fig. 1116).

The Radio Amateur's Handbook

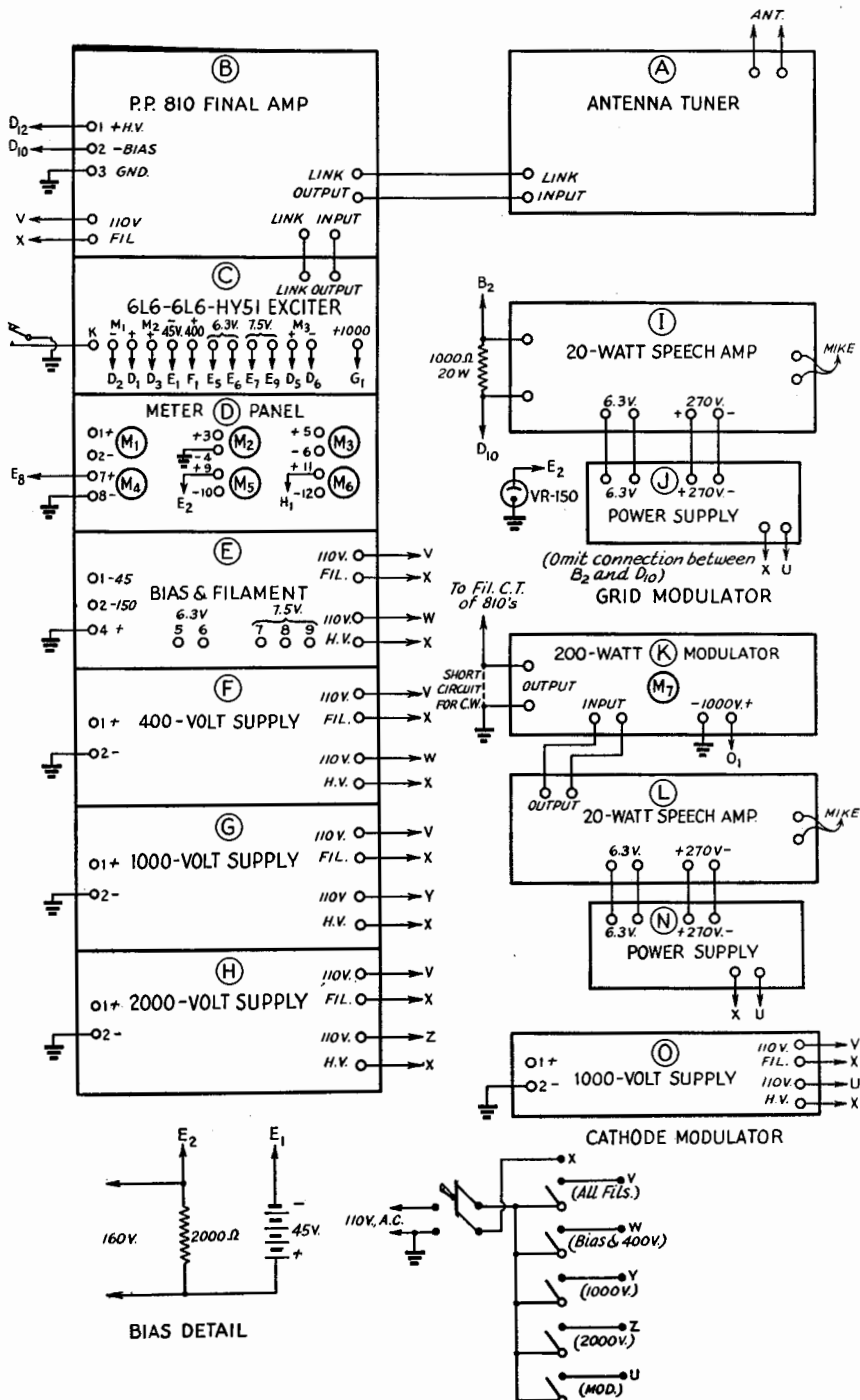

Fig. 1314 — Complete layout for 1-kw. transmitter, including optional modulation systems.

A — Antenna tuner. Circuit diagram same as Fig. 1051, layout Fig. 1050. Use condenser with 240 μ fd. per section, 0.1-in. spacing. (Cardwell

XE240KD.) Use B & W HDVL series or equivalent for coils.

B — Push-pull final amplifier, 810's (Fig. 1044) operated at 2000 volts, 500 ma. for telegraphy.

C — 6L6-6L6-HY51 exciter (Fig. 1025).

Complete Transmitters

vidually. This disadvantage is overcome in *C* where the meters are connected across low resistances in grid and plate return circuits. M_1 reads grid current and M_2 plate current. The resistance should be of a value of not more than 10 to 20 times the resistance of the meter and should be of sufficient power rating so that there will be no possibility of resistor burn-out. If desired, the resistance values may be adjusted to form a multiplier scale for the meter (see Chap. 17). The same principle is used in the meter switching system of Fig. 1304.

Meters may also be shifted from one stage to another by a plug and jack system, but this system should not be used unless it is possible to ground the frame of the jack or unless a suitable guard is provided around the meter jacks to make personal contact with high voltages impossible in normal use of the plug.

Complete Transmitters

Several examples of the correct combining of units described in Chapters 10, 11 and 12 are shown in the sketches of Figs. 1305 to 1314. They are complete from antenna tuners to control systems. Essential information is given under each sketch and references are made to descriptions of each individual unit used.

D — Meter panel.

- M_1 — Oscillator cathode meter (0–100 ma.).
- M_2 — Doubler cathode meter (0–150 ma.).
- M_3 — Buffer grid meter (0–100 ma.).
- M_4 — Buffer cathode meter (0–500 ma.).
- M_5 — Final grid meter (0–200 ma.).
- M_6 — Final plate meter (0–1000 ma.).

E — Bias and filament-supply unit, containing 160-volt bias pack and 45-volt battery. (See detail.)

Also 6.3-volt, 2-amp. transformer and 7.5-volt, 4-amp. transformer for exciter.

F — 400-volt, 200-ma. supply.

G — 1000-volt, 250-ma. supply (Fig. 1116).

H — 2000-volt, 500-ma. supply (Fig. 1124).

Grid modulator.

I — 20-watt speech amplifier (Fig. 1207). Output transformer set at turns ratio primary to secondary 3.14 to 1, with 1000-ohm loading resistance as shown and VR150 for regulating bias voltage. Operating conditions for final amplifier — grid current — 4 ma., plate current — 184 ma., driving power — 8 watts (load driver as described in Chap. 16). Power output 120 watts.

J — Power-supply unit delivering 270 volts, 200 ma. and 6.3 volts, 4-amp. for modulator.

Cathode modulator.

K — 200-watt modulator, similar to Fig. 1224 with

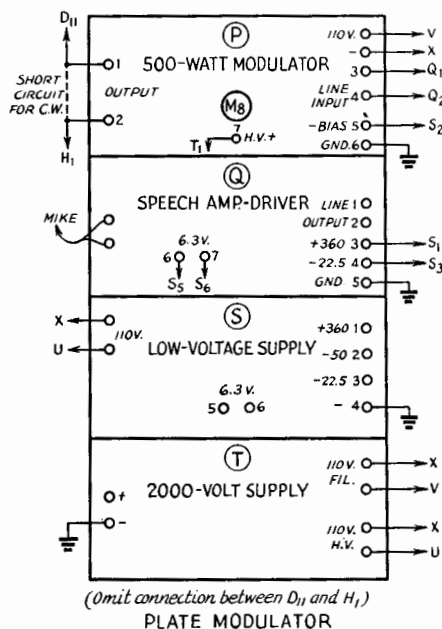

Fig. 1314A — Plate modulator for 1-kw. transmitter.

P — 500-watt modulator, similar to Fig. 1226 with 810 tubes operating at 2000 volts plate, 50 volts bias, or other tubes adjusted for 500-watt output, with line-to-grid input transformer. Output transformer set for 11,000 ohms primary to 3600 ohms secondary (M_8 —0–1000 ma.).

Q — 30-watt speech-amplifier-driver (Fig. 1210). Plate-to-line output transformer.

S — Power-supply unit for speech-amplifier-driver. 360-volts, 250 ma. and 6.3 volts, 4 amp. Also contains 50-volt biasing battery for modulator and 22.5-volt biasing battery for driver.

T — 2000-volt, 500-ma. supply for modulator (Fig. 1124).

Operating conditions for final amplifier-plate — 1800 volts, 500 ma., grid — 200 volts, 100 ma.

Input 900 watts, output 670 watts.

203-A tubes operating at 1000 volts, 35-volt bias, or other tubes adjusted for 200-watt output. Output transformer set for 6900 ohms primary to 2200 ohms secondary (M_7 —0–500 ma.).

L — 20-watt speech amplifier-driver. (See I.) Plate-to-line output transformer.

N — 270-volt and 6.3-volt power supply for speech-amplifier-driver. (See J.)

O — 1000-volt, 250-ma. supply for modulator. (See G.) Operating conditions for final amplifier-plate — 1800 volts, plate current 325 ma., power input 585 watts, power output 315 watts.

Transmitter Adjustment

Tuning Crystal Oscillators, Frequency Multipliers and Power Amplifiers — Neutralizing — Adjustment of Coupling and Excitation — Trouble-Shooting

Tuning Triode, Tetrode or Pentode Crystal Oscillators

THE tuning characteristics and procedure to be followed in tuning are essentially the same for a triode, tetrode or pentode crystal oscillator. In each case, tuning is chiefly a matter of obtaining the greatest amount of power output consistent with safe input and reliable crystal operation.

Using a plate milliammeter as an indicator of oscillation (a 0–100 ma. d.c. meter will have ample range for all low-power oscillators), the plate current will be found to be steady when the circuit is in the non-oscillating state, but will dip when the plate condenser is tuned through resonance at the crystal frequency. Fig. 1401 is typical of the behavior of plate current as the tank condenser capacity is varied. As the capacity is increased from minimum, there will be a rather gradual decrease in plate current after oscillations commence. This continues until the point *A* is reached, when there will be a sharp rise in plate current, followed by cessation of oscillations. An r.f. indicator, such as a small neon bulb touched to the plate end of the tank coil, will show maximum at point *A*. However, when the oscillator is delivering power to a load it is best to operate in the region *B-C*, since the oscillator will be more stable and there is less likelihood that a slight change in loading will throw the circuit out of oscillation. This is likely to happen when operation is too near the critical point, *A*. Also, the crystal current is lower in the *B-C* region.

When power is taken from the oscillator, the dip in plate current is less pronounced, as indicated by the dotted curve. The greater the power output the less is the dip in plate current. If the load is made too great, oscillations will

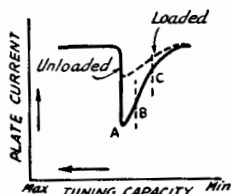

Fig. 1401 — D.C. plate current vs. plate tuning capacity with the triode, tetrode or pentode crystal oscillator.

not start. Loading is adjusted by varying the coupling to the load circuit which may be the antenna or a following stage.

The greater the loading, the smaller the voltage fed back to the grid circuit for excitation purposes. This means that the r.f. voltage across the crystal also will be reduced, hence there is less crystal heating when the oscillator is delivering power than when operating unloaded. For this reason it is possible to operate a loaded oscillator at higher plate voltage than is possible with an unloaded oscillator for the same crystal heating.

Special care should be exercised, particularly with triodes to prevent dangerously high crystal currents by running the oscillator unloaded for extended periods or using high plate and screen voltages.

Tuning the Tri-tet

The tuning procedure for this circuit is as follows: With the cathode tank condenser at about three-quarters scale, turn the plate tank condenser until there is a sharp dip in plate current, indicating that the plate circuit is in resonance. The crystal should be oscillating

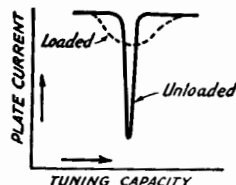

Fig. 1402 — D.C. plate current vs. plate tuning capacity with the Tri-tet oscillator.

continuously regardless of the setting of the plate condenser. Set the plate condenser so that plate current is minimum. The load circuit may then be coupled and adjusted so that the oscillator delivers power. The minimum plate current will rise; it may be necessary to retune the plate condenser when the load is coupled to bring the plate current to a new minimum. Fig. 1402 shows the typical behavior of plate current with plate-condenser tuning.

After the plate circuit is adjusted and the oscillator is delivering power, the cathode condenser should be readjusted to obtain

Transmitter Adjustment

optimum power output. The setting of this condenser should be as far toward the low-capacity end of the scale as is consistent with good output; it may, in fact, be desirable to sacrifice a little output if so doing reduces the current through the crystal and thus reduces heating.

In obtaining harmonic output, it is merely a matter of tuning the plate tank circuit to the harmonic rather than the fundamental of the crystal frequency. A plate-current dip will be found at the harmonic also. If the cathode condenser is adjusted for maximum output at the harmonic, this adjustment will usually serve for the fundamental as well. The crystal should be checked for evidence of excessive heating. The most satisfactory remedy is to lower plate or screen voltages of both or by reducing the load. It should be noted that with this circuit maximum r.f. voltage across the crystal is developed at maximum load in contrast to the triode-pentode circuit and crystal heating should be checked with the load coupled.

The Grid-Plate Oscillator

The tuning characteristics of the grid-plate oscillator are very similar to that of the Tri-tet with the difference that the tuning of the cathode circuit is often fixed as described in Chap. 5. The output at even harmonics is less than that obtainable with the Tri-tet but greater at odd harmonics. Trouble is often experienced in obtaining second-harmonic output from 1.7-Mc. crystals, although this difficulty is not usually experienced with crystals of higher frequency.

Oscillator Efficiency

The efficiency of the triode oscillator will be somewhat less than that of the others mentioned when the latter are operated at the crystal fundamental because of the greater excitation requirements of the triode. The other circuits should show efficiencies at the fundamental of 50 to 60 per cent, so that they should deliver an output of 50 to 60 per cent of the plate power input. At the second harmonic, the efficiency of the Tri-tet, when correctly adjusted, will run about 40 per cent.

Oscillator Troubles

Excessive r.f. voltage across the crystal will cause heating with resulting "creep" in frequency if not fracture of the crystal. To prevent this, the r.f. current through the crystal should never exceed the crystal manufacturer's rating. This current may be estimated by connecting a flashlight bulb of proper current rating in series with the crystal. The size of the lamp should be chosen so that it glows when the current rating of the crystal is exceeded.

Failure of a crystal circuit to oscillate may be caused by any of the following:

1. Dirty, chipped or fractured crystal
2. Imperfect or unclean holder surfaces
3. Overloading
4. Plate or cathode tank circuit not tuning correctly
5. Insufficient feedback with the pentode circuit

The last trouble should be suspected only when well screened tubes, such as the receiver-type r.f. pentodes and the types RK23-25, 802, 807 or similar types are concerned. This may be remedied by introducing a *small* capacity externally between grid and plate. This should be no larger than is necessary to maintain oscillation with a reasonable load. Usually a short piece of insulated wire connected to each of the plate and grid prongs of the socket and the two insulated free ends twisted together will be sufficient.

In regard to item (4), make certain that the plate tank coil tunes to resonance at the desired frequency. Remember that capacity coupling to the load will increase the capacity across the plate tank coil so that resonance will occur at a lower-capacity setting of the condenser — possibly lower than will regain resonance without a reduction in the size of the plate coil. This applies particularly when pentodes or tetrodes are capacity-coupled.

The remedies for the remainder are obvious. Don't overlook the great possibility of a mistake in wiring, especially the connections to a multi-element tube.

Parasitic Oscillations

One effect most likely with beam tubes is a tendency for apparently strong parasitic oscillation, as indicated by high r.f. crystal current when the plate tank is tuned lower than the crystal frequency. This is more marked with these tubes in a simple tetrode circuit than in the Tri-tet but occurs in both. Since it is not generally an oscillation of crystal frequency, but is a parasitic phenomenon resulting from the high mutual of these tubes, it does not excite the crystal and is likely to cause damage only to the tube if allowed to persist.

● AMPLIFIER ADJUSTMENT

Adjustment of Bias

The first step in adjusting an r.f. amplifier for the first time is that of setting the bias for the conditions under which it is desired to operate. A wide range of conditions is possible and the matter is discussed in Chap. 5.

All transmitting tubes, except those designed primarily for Class-B audio service with zero bias will draw excessive plate current when

The Radio Amateur's Handbook

excitation is removed unless provided with a certain minimum fixed bias of sufficient value to hold the plate current to a safe value. The value of fixed biasing voltage which will reduce plate current to zero when excitation is removed is known as the cut-off voltage and is very nearly equal to the plate voltage at which the tube is operating divided by the amplification factor of the tube.

While simple grid-leak biasing is the simplest, most economical, and most desirable in the operation of a Class-C amplifier, it does not provide the protection required on failure or removal of excitation. Therefore, it is common practice to provide cut-off bias from a fixed source, such as a battery or power pack of proper design (see Chap. 11) and obtain the remainder of the operating bias from a grid leak.

Recommended operating voltages and currents will always be found in the sheet which manufacturers furnish with each power tube. These include a value of biasing voltage and often a value of grid-leak resistance. In most cases, the value of grid-leak resistance recommended does not take any fixed bias into consideration. To determine the grid-leak resistance which should be used when a combination of batteries for fixed bias and grid leak is to be used, the battery voltage, which should be as near to the required cut-off value as possible, should be subtracted from the recommended operating bias to obtain the voltage required from the grid leak. The grid-leak resistance required is then computed by dividing the additional biasing voltage required by the recommended d.c. grid current in decimal parts of an ampere. For example, the recommended conditions for Class-C operation of the RCA 203A for telephony are: plate voltage, 1000; grid bias, 135; d.c. grid current, 50 ma. (0.05 amp.). The amplification factor is given as 25 so that cut-off bias for 1000 volts is $\frac{1000}{25}$ or 40 volts. Assuming the use of a

25

45-volt battery, the remaining voltage required from the grid leak is 135-45 or 90 volts. The grid-leak resistance is equal to $\frac{90}{0.05}$ or 1800 ohms.

0.05

If a bias pack is to be used, the bleeder or voltage-divider resistance should be adjusted as described in Chap. 11.

Amplifier Tuning

The general method of tuning applies to any type of amplifier of circuit. Triodes, of course, have to be neutralized, while screen-grid tubes do not. Aside from neutralization, the tuning process consists of adjusting the input circuit for maximum excitation, and the output circuit for optimum power output and efficiency.

When triode amplifiers are used, it is essential that the tube or tubes be carefully neutralized before attempting to take power output from the circuit or adjusting for maximum excitation. Neutralization is therefore the next step in the tuning process.

Neutralizing Adjustments

The procedure in neutralizing is the same for all tubes and circuits. The filament of the tube should be lighted and the excitation from the preceding stage should be fed to the grid circuit, *but the plate voltage should be off of the amplifier.*

The grid-circuit milliammeter is one of the best and safest neutralizing indicators because it does not require placing the hands close to apparatus which may carry high voltages. If the circuit is not completely neutralized, tuning of the plate tank circuit through resonance will change the tuning of the grid circuit and affect its loading, causing a change in the d.c. grid current. With push-pull amplifiers, or single-ended amplifiers using a tap on the tank coil for neutralization, the setting of the neutralizing condenser which leaves the grid current unaffected as the plate tank is tuned through resonance is the correct one. If the circuit is out of neutralization, the grid meter needle will give a noticeable dip. As the point of neutralization is approached, by adjusting the neutralizing capacity bit by bit, the dip in grid current as the plate condenser is swung through resonance will become less and less pronounced until, at exact neutralization, no dip at all will be found. Further adjustment of the neutralizing condenser in the same direction will bring the grid-current dip back. The neutralizing condenser should always be adjusted with a screwdriver of insulating material. Screwdrivers with metal shafts will affect the adjustments.

Adjustment of the neutralizing condenser may affect the tuning of the grid tank or driver plate tank, so they should be retuned each time a change is made in neutralizing capacity. In neutralizing a push-pull amplifier, the neutralizing condensers should be adjusted together, step by step, keeping their capacities as equal as possible.

The adjustment of neutralizing condensers of the usual multi-plate type will be more critical than with the low-capacity types which consist of a stationary plate and a second plate mounted on a threaded shaft. The change in capacity of the latter type is relatively slow until the plates are close together.

With single-ended circuits having split-stator neutralizing, the behavior of the grid meter will depend somewhat upon the type of tube used. If the tube's output capacity is not great enough to upset the balance, the action

Transmitter Adjustment

of the meter will be the same as in other circuits. With high-capacity tubes, however, the meter usually will show a gradual rise and fall as the plate tank is tuned through resonance, reaching a maximum right at resonance when the circuit is properly neutralized.

If a grid meter is not available, the amplifier may be neutralized by checking in a similar manner with the driver plate-current meter.

Other Neutralizing Indicators

When an amplifier is not neutralized, a neon bulb touched to the plate of the amplifier tube or to the plate side of the tuning condenser will glow when the tank circuit is tuned through resonance, providing the driver has sufficient power. The glow at resonance will disappear when the amplifier is neutralized.

A flashlight bulb connected in series with a single loop of wire $2\frac{1}{2}$ or 3 inches in diameter with the loop coupled to the tank coil will, in a similar manner, serve as a neutralizing indicator.

Aside from the angle of safety which makes the grid meter preferable as an indicator, touching the neon bulb to a high-potential point of the circuit may introduce enough stray capacity to unbalance the circuit slightly, thus upsetting the neutralizing in a circuit using a split-stator condenser. This is particularly noticeable with high-power amplifiers where the excitation voltage is considerable and a slight unbalance gives a noticeable indication. This capacitive unbalance is usually less pronounced with the flashlight bulb and loop, especially if it is possible to couple to the low-potential point of the tank circuit.

Neutralizing Difficulties

If trouble is experienced in getting a triode amplifier completely neutralized, the circuit should be checked over carefully to make sure that all connections are good and that there are no shorted turns in the inductances. Different sizes of neutralizing condensers may also be tried, since circuit conditions vary considerably with different physical layouts. If a setting of the neutralizing condenser can be found which gives minimum r.f. in the plate tank circuit without completely eliminating it, the chances are that there is some magnetic or capacity coupling between the input and output circuits external to the tube itself. Short leads in neutralizing circuits are highly desirable, and the input and output inductances should be so placed with respect to each other that magnetic coupling is minimized. Usually this means that the axes of the coils should be at right angles to each other. In some cases it may be necessary to shield the input and output circuits from each other. Magnetic coupling can be checked for quite readily by disconnecting the tank from the remainder of the

circuit and testing for r.f. in the plate tank circuit as the tank condenser is swung through resonance. The preceding stage must be running, of course.

Particularly with single-ended amplifiers there are many stray capacities left uncompensated for in the neutralizing process. The tube, for example, has capacity from grid to filament as well as from grid to plate; likewise there is capacity between plate and filament. Similarly, capacities existing between parts of the socket enter into the picture with tubes having all three elements brought out to the same base. With large tubes, especially those having relatively high interelectrode capacities, these commonly neglected stray capacities can prevent perfect neutralization. Symmetrical arrangement of a push-pull amplifier is about the only way to obtain a practically perfect balance throughout the amplifier.

When employing a split-stator tank condenser with a tube having a fairly high output capacity, it may be impossible to maintain exact neutralization except at exact resonance, especially if the circuit tunes to resonance near minimum capacity of the tank condenser when the stray circuit capacities may have more to do with determining the capacity balance than the capacity of the tank condenser itself. The percentage of variation between the capacities of the two condenser sections may also be much higher near minimum capacity. It is, therefore, desirable to have the coil proportioned so that resonance occurs with the condenser set at a fair percentage of its total capacity.

Sometimes, it may be necessary to connect a small variable capacity across one half of the circuit, as shown in Fig. 1403 to compensate for the output capacity of the tube across the other half.

The neutralization of tubes with extremely low grid-plate capacity, such as the 6L6, is often very difficult. It often happens that the wiring itself will introduce sufficient capacity between the right points to "over-neutralize" the grid-plate capacity. The use of a neutralizing condenser only aggravates the condition. Inductive or link neutralization as shown in Fig. 1404 has been used successfully with tubes such as the 6L6.

Adjustment of Excitation

The desirability of having a fully adequate source of excitation cannot be over-emphasized. This applies particularly to a triode which is to be operated at high efficiency as a Class-C plate-modulated amplifier. Upon this one factor more than anything else may depend the success or failure of the amplifier in operating properly. It is always better to err on the side of excessive available excitation. An amplifier driven by an exciter with barely

The Radio Amateur's Handbook

enough power to do the job will require precise tuning and adjustments of coupling each time frequency is changed appreciably and, more often than not, it will be found necessary to depend upon regeneration, with its attendant uncertainty, to maintain adequate excitation.

In adjusting amplifier excitation, the grid-current meter is again the best indicator. With the bias and grid-leak requirements determined and set, the object is to adjust the driver and the coupling for maximum grid current consistent with the driver loading. The preliminary adjustments are made with no plate voltage applied to the amplifier.

In capacity-coupled systems, the principal adjustment for maximum excitation is that of tuning the driver plate circuit to resonance after the grid of the amplifier has been coupled to it. Because of the added shunt capacity, driver resonance will occur at a lower-capacity setting of the driver tank condenser than without the amplifier coupled. As the load of the amplifier grid circuit is coupled, the driver plate current at resonance will rise, the dip becoming less pronounced. This should be accompanied with a rise in grid current coinciding with the dip in driver plate current.

If excitation is taken directly from the end of the driver tank coil, the only remaining adjustment possible is a variation in the capacity of the coupling condenser, larger values usually resulting in heavier loading of the driver and increased excitation. In certain instances, however, a smaller capacity may result in increased grid current. If the driver is an oscillator, the coupling should not be so tight as to prevent ready starting of crystal oscillations.

In cases where the preceding adjustments do not load the driver up to its rating and it is evident that the amplifier requires more excitation, the only recourse may be to tapping the driver plate coil. This is sometimes necessary when the plate impedance of the driver differs considerably from the grid impedance of the amplifier. When the grid impedance is much higher than the plate impedance, it will be necessary to tap the plate of the driver down

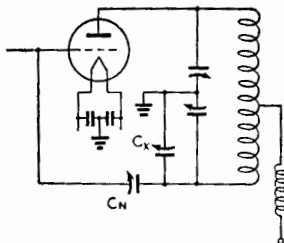

Fig. 1403 — Connection of condenser to balance output capacity of tube for accurate neutralization. C_x is the balancing condenser, C_n the neutralizing condenser.

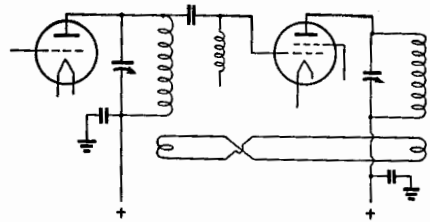

Fig. 1404 — Link neutralizing for tetrodes and pentodes, such as 6L6, 6V6 and other tubes sometimes difficult to neutralize by other methods. The link coils should have one or two turns and should be coupled to the "cold" ends of the tank coils. Neutralization is adjusted by moving the link coils in relation to the tank coil. Reversal of connections to one of the coils may be required.

on the tank coil, while if the reverse is true, the amplifier grid must be tapped down. If the tank condenser has sufficient capacity range, a decrease in the $L-C$ ratio in the driver tank may improve conditions as a substitute for tapping.

Link-Coupling Adjustments

In the adjustment of excitation with link coupling, the same principles apply. Here, both the driver plate and amplifier grid tank circuits must be adjusted simultaneously for maximum grid current. The tuning of the two circuits invariably interlocks so that it may be necessary to "juggle" the tuning of the two circuits for maximum excitation. Coupling is adjusted by either changing the number of turns in each link coil or by increasing or decreasing the coupling between the link windings and their associated tank coils. Both are often required.

If the grid impedance is high, the $L-C$ ratio in the grid tank circuit may be high, while a low ratio is desirable in coupling to a low-impedance grid circuit. In certain instances, it may be necessary to tap the grid or plate connections as described under adjustments with capacity-coupled systems.

Excitation Troubles

Under recommended conditions of bias, the grid current value obtained before plate voltage or load is applied to the amplifier should run 25 to 30 percent higher than the value given for typical operating conditions. If this value is not obtained, and the driver input is running up to rated value, the most common reason is that the ability of the driver has been overestimated. Driver operating voltages should be checked to assure they are up to rated values, however. If batteries are used for biasing and are not strictly fresh, they should be replaced, for batteries which have been in use for some time often develop high internal resistance which effectively adds to the grid-leak resistance. This may be true even though a check

Transmitter Adjustment

shows the battery voltage to be normal. If a pack is used, the bleeder or voltage-divider resistances should be checked to make certain that low grid current is not due to greater grid-circuit resistance than is recommended. There is also the possibility of loss of filament emission either from prolonged service or from operating the filament under or over the rated voltage. It is important that the filament be operated as close as possible to rated voltage measured at the tube socket.

Amplifier Plate Tuning

After adjustments to the input circuit have been completed, plate voltage may be applied to the amplifier. In preliminary tuning, it is desirable to use low plate voltage to avoid possible damage to the tube. With excitation and plate voltage applied, rotate the plate tank condenser until the plate current dips; set the condenser at the minimum plate-current point which is resonance. When the resonance point has been found, the plate voltage may be increased to its normal value.

With adequate excitation, the off-resonance plate current of a triode amplifier may run two to three or more times the normal operating value. With screen-grid tubes, the off-resonance plate current may not be much higher than the normal operating value because of screen action.

With reasonably efficient operating conditions, the minimum plate current with the amplifier unloaded will be a small fraction of the rated plate current for the tube, usually a fifth or less. If the excitation is low, the "dip" will not be very marked, but with adequate excitation the plate current at resonance without loading is just high enough so that the d.c. plate power input supplies all the losses in the tube and circuit. The higher the unloaded tank impedance, the lower the minimum plate current. For this reason, large $L-C$ ratios give very low values of plate current; conversely, a fairly high- C tank will give somewhat larger values. As an indication of probable efficiency, the minimum plate current value should not be taken too seriously, however, especially when a fair amount of tank capacity is in use, because in the unloaded condition the circulating r.f. current in a high- C tank is large and, since the losses vary with the current squared, the losses under no-load conditions may be rather high compared to those in a very low- C tank. When the amplifier is delivering power to a load, the circulating current drops considerably and the tank losses correspondingly decrease, so that under load conditions the actual efficiency is about the same with a tank of optimum $L-C$ ratio as with one having extremely low C .

The condition of high minimum unloaded

plate current is most often encountered at the very high frequencies where low-loss tank circuits with high $L-C$ ratios are difficult to obtain. It is particularly noticeable with screen-grid tubes of high output capacity which make a high $L-C$ ratio impossible. It will be found, however, that fairly good efficiencies are usually obtained when the load is coupled.

Loading the Amplifier

With the load — antenna or following amplifier grid circuit — connected, the coupling between plate tank and load should be adjusted to make the tube take rated plate current, keeping the tank always in resonance.

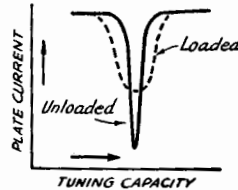

Fig. 1405 — Typical behavior of d.c. plate current with tuning of an amplifier.

As the output coupling is increased, the minimum plate current will also increase about as shown in Fig. 1405. Simultaneously, the tuning becomes less sharp, because of the increase in effective resistance of the tank. If the load circuit simulates a resistance, the resonance setting of the tank condenser will be practically unchanged with loading; this is generally the case since the load circuit itself usually is also tuned to resonance. A reactive load (such as an antenna or feeder system which is not tuned exactly to resonance) may cause the tank condenser setting to change appreciably with loading.

As the plate loading is increased, with its accompanying increase in plate current, the grid current usually will fall off somewhat, because as more electrons are drawn from the cathode by the plate, less are available for the grid if the exciting voltage remains constant. The decrease in grid current depends upon a number of factors: the value of plate current, the type of tube, the voltage regulation of the driver, the amount of excitation power available, and to some extent upon the circuit used. This last is particularly true of single-ended amplifiers, as was discussed in the section on neutralizing circuits.

The significant value of grid current is that which flows when the amplifier is loaded to rated plate current and tuned to resonance. As the plate tank circuit is tuned through resonance, the grid current will normally rise somewhat at resonance as the plate current dips, tending to keep the total space current constant. The grid-current figures given in the tube tables of Chap. 20 are for loaded condi-

The Radio Amateur's Handbook

tions at the recommended bias. Under load conditions, the grid current should never exceed the maximum rated value. If higher grid currents are experienced, driver coupling or power should be reduced.

Checking Power Output — Dummy Antennas

As a check on the operation of an amplifier, its output may be measured to a close approximation by the use of an artificial load of known rating coupled to the amplifier output as shown in Fig. 1406. At *A* and *B*, a thermo-

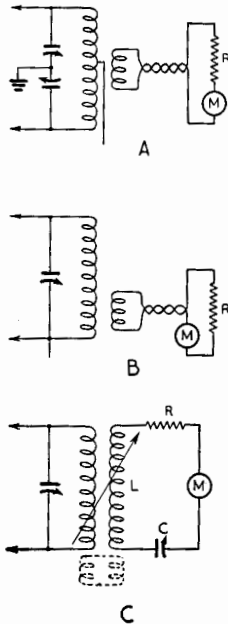

Fig. 1406 — Dummy-load circuits for measuring power output and preliminary tuning. *A* — For balanced tank circuits. *B* — For single-end tank circuits. *C* — For high-resistance loads where sufficient coupling cannot be obtained by the methods of *A* and *B*. *M* is an r.f. thermo-ammeter, *R* a non-inductive resistance of proper rating. In *C*, *L* and *C* should tune to the output frequency of the amplifier. Coupling may be adjusted by the physical separation between the two tank circuits or by adjusting a link line between the two as shown in dotted lines.

When less accurate measurement will suffice, ordinary 110-volt lamp bulbs may be used to replace the meter and resistance.

ammeter *M* and non-inductive resistance *R* are connected across a link coupled to the amplifier tank coil. If the tank coil is fitted with a swinging link or adjustable coupling coil, the amplifier loading may readily be adjusted so that the amplifier draws rated plate current when tuned to resonance. Otherwise, a link winding of good high-voltage wire may be wrapped around the low-potential section of the tank coil and the turns varied until proper loading is obtained. The power output is then calculated from Ohm's Law:

$$P \text{ (watts)} = I^2 R$$

where *I* is the current indicated by the thermo-ammeter and *R* is the resistance of the non-inductive resistor. Special resistance units are available for this purpose ranging from 73 to 600 ohms at power ratings up to 100 watts. For higher powers, the units may be connected in series-parallel. The 73-ohm size is often used because it approximates the impedance at the

center of a half-wave antenna and that of certain types of low-impedance transmission lines. The size of meter required for any expected value of power output may also be determined from Ohm's Law given above:

$$I = \text{square root of } \frac{W}{R}$$

If higher values of dummy load resistance are used, it may be necessary to place the dummy resistor and meter in series with a tank circuit tuned to the frequency of the amplifier. Otherwise, it may be difficult to obtain sufficient coupling to load the amplifier properly.

An excellent, although somewhat less accurate, dummy load may consist of an ordinary 110-volt incandescent lamp of wattage rating equal to the power output to be expected from the amplifier as a substitute for the non-inductive resistor and meter. The lamp coupled to the amplifier in the same manner will indicate power by its degree of illumination. By selecting a lamp of power rating close to that to be expected from the amplifier, the power output may be estimated quite closely by comparing the brilliance of the lamp used as the dummy load with that of a duplicate lamp operating in the 110-volt line. Lamps may be connected in series, parallel or series-parallel to handle high power output.

Amplifier Efficiency

The over-all efficiency of a Class-C amplifier will vary considerably depending upon the conditions of bias, excitation and loading under which it is operated as well as the efficiency of the tank circuit. With high bias and high excitation over-all efficiencies up to 75 per cent may be expected at medium frequencies, with the possibility of the figure dropping to as low as 50 per cent at frequencies as high as 28 Mc. with average tank-circuit efficiency. When the operating values are chosen for maximum power gain (see Chap. 5), efficiencies will run somewhat lower.

A rough estimate of the overall efficiency of an amplifier is obtained by determining the ratio of power output as estimated with the dummy load to the power input (the product of the plate voltage and plate current).

Tuning of Frequency Doublers

Frequency multipliers are tuned in much the same way as straight amplifiers. Once the bias or grid-leak values are chosen, the input or grid circuit should be adjusted for maximum grid current just as with the straight amplifier. Then the plate voltage may be applied and the plate tank circuit tuned to the second harmonic, which will be indicated by the dip in plate current. The dip usually will not be as pronounced as with straight amplifiers, how-

Transmitter Adjustment

ever. Once these adjustments have been made the load may be connected and adjusted for maximum output consistent with the plate current rating of the tube. Since the efficiency is lower, it may be necessary to use lower than rated plate current, especially if the plate of the tube shows color.

After the adjustments have been completed it is a good plan to change the bias voltage or the resistance of the grid leak to find the value which gives greatest output. Highest efficiency will result when the grid bias or grid leak are as high in value as is possible with the grid excitation available. Under optimum operating conditions, the plate efficiency of a doubler runs about 40%.

● TRANSMITTER TROUBLES

Inexact neutralization or stray coupling between plate and grid circuits often result in regeneration when the plate tank circuit is tuned slightly to the high-frequency side of resonance. This effect is most evident when excitation is low when the amplifier will show a sudden increase in output when tuned slightly off resonance. This may be accompanied by a pronounced increase in grid current.

If the feedback caused by inaccurate neutralization or stray coupling is sufficient, the amplifier may self-oscillate at or near the operating frequency. This is quite obvious when the amplifier shows evidence of output near the operating frequency with the excitation removed. The remedies for both regeneration and oscillation are more exact neutralization and better isolation of input and output circuits. In some cases, shielding between the two will help.

Self-oscillation is quite apt to occur with tubes of high power sensitivity such as the r.f. pentodes and tetrodes. In event of either regeneration or oscillation, circuit components should be arranged so that those in the plate circuit are well isolated from those of the grid circuit. Plate and grid leads should be made as short as possible and the screen should be well by-passed as close to the socket terminal as possible. A cylindrical shield surrounding the lower portion of the tube up to a point even with the lower edge of the plate is sometimes required. In one popular type of shielded construction, the tube base and grid-circuit components are placed beneath the chassis, while the plate-circuit components are placed above.

Double-Resonance

A peculiar case of unorthodox amplifier operation occasionally encountered with triodes but more often with beam tetrodes is one in which the maximum power output occurs not at resonance as indicated by plate-current dip,

but at a point which may be appreciably removed. It may be remedied by moving the plate connection down on the tank coil until it disappears or by decreasing the $L-C$ ratio of the tank circuit.

Secondary Emission

The most serious cases of secondary emission usually occur in tubes of smaller sizes which are being operated at above normal voltages. The emission usually takes place from the grid which becomes sufficiently hot to start emitting electrons. The emission increases the heat and the result is a gradual increase in plate current to abnormal value which can be stopped only by removing plate voltage and allowing the tube to cool off. If allowed to persist for any length of time, the tube will be ruined.

● PARASITIC OSCILLATIONS

If the circuit conditions in an oscillator or amplifier are such that self-oscillations at some frequency other than that desired exist, the spurious oscillation is termed *parasitic*. The energy required to maintain a parasitic oscillation is wasted so far as useful output is concerned, hence an oscillator or amplifier having parasitics will operate at reduced efficiency. In addition, the behavior of plate current often will be erratic.

Parasitic oscillations may be higher or lower in frequency than the nominal frequency of the amplifier.

On occasion, the parasitic oscillation may take place the instant plate voltage is applied or, when the amplifier is biased beyond cut-off, at the instant excitation is applied. Frequently the oscillation will be sustained after the excitation has been removed. Under these circumstances, the presence of parasitics is quite apparent because the amplifier continues to draw abnormal plate current. If oscillations are of the u.h.f. type, they may be so violent as to ruin the tube in short order if allowed to persist. In cases such as these, plate voltage should be reduced to the minimum which will sustain the oscillation so that it can be investigated. A resistance in the positive high-voltage line or a lamp in series with the plate-transformer primary will limit the plate current.

At other times, when the amplifier is biased beyond cut-off, the oscillation may not be self-sustaining. It may become active only in the presence of excitation and may be apparent only by the production of abnormal key clicks at intervals over a wide frequency range or splatter with modulation.

A test for parasitics should always be made before placing an amplifier in operation for the first time. This can be done by removing the

The Radio Amateur's Handbook

excitation, applying plate voltage and lowering the bias until the tube draws a fair amount of plate current. If on tuning the plate tank circuit, the plate current remains steady and a neon-bulb test shows no r.f. energy, it is quite probable that the amplifier will be free from parasitics.

Low-Frequency Parasitics

Low-frequency parasitic oscillations are usually caused by tuned grid and plate circuits formed by r.f. chokes tuned to nearly the same frequency by associated coupling and by-pass condensers. The usual tank coils represent negligible inductance at low frequencies and they may be short-circuited without affecting the oscillations. Sometimes the tank condenser may assist in the tuning. A neon bulb touched to the plate of the amplifier tube usually exhibits a glow more on the yellowish-orange side than normally. If search is made on a receiver with a wide tuning range while the amplifier is excited, signals usually of rough character will be found spaced at regular intervals, depending upon the frequency of the parasitic, over a wide range.

Low-frequency parasitics can almost always be avoided by observing two simple rules in the design of the amplifier. These are as follows:

1. In series-fed plate circuits, never use r.f. chokes except when a split-stator tank condenser is used.
2. If the split-stator condenser is used, always use a grid leak in series with the grid-circuit r.f. choke and do not by-pass the lower end of the grid choke.

High-Frequency Parasitics

In circuits in which some point on the plate tank coil is grounded for neutralizing, a circuit for high-frequency parasitic oscillations is formed if the grid or driver plate are tapped down on the driver plate tank coil. This circuit is not formed when split-stator neutralizing is used.

Ultra-High Frequency Parasitics

U.h.f. parasitic oscillations are caused by resonance in grid and plate connecting leads of a neutralized amplifier. (See Fig. 1407.) A neon bulb touched to the plate of the amplifier tube usually glows with a predominantly violet light. This type of oscillation may or may not produce extraneous signals at frequencies lower than that of the oscillation if the amplifier is excited. They usually produce pronounced clicks or splatter about the carrier frequency if the amplifier is keyed or modulated.

The frequency may be determined by connecting a tuned circuit in series with the grid lead to the tube. A variable condenser of 100

$\mu\text{mfd.}$ or so may be used in conjunction with three or four self-supporting turns of heavy wire an inch or so in diameter. With the amplifier oscillating at the parasitic frequency,

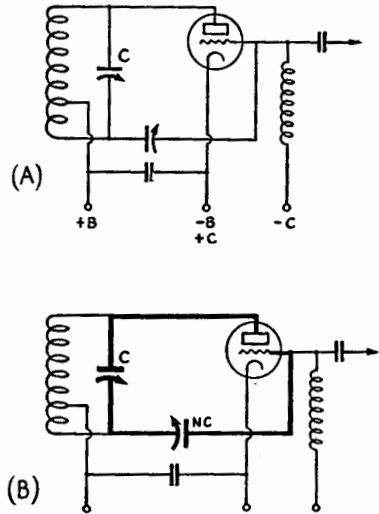

Fig. 1407 — The most common u.h.f. parasitic circuit. The leads are long enough to form the ultraudion oscillating circuit. This form may be identified by removing the tank coil and touching the h.v. lead to the tank-condenser stator. The oscillation will persist. This type is less apt to occur with split-stator neutralizing.

the condenser is slowly tuned through its range until oscillations cease. In case this point is not found on first trial, the turns of the coil may be spread apart or a turn removed and the process repeated. While this may not be the simplest cure in all cases, the use of such a tuned circuit as a trap is an almost certain remedy, if the frequency can be located, and introduces little if any loss at the operating frequency. Once the values of L and C for the trap have been determined, it may be possible to replace the experimental trap with components of smaller physical size. A rearrangement of parts in which shorter leads may be used is the alternative remedy.

● HARMONIC SUPPRESSION

Unless certain precautions are taken a transmitter may feed energy to the antenna system at harmonics of the fundamental frequency as well as at the fundamental frequency. If the antenna system is suitable for these harmonic frequencies, the amount of power radiated at these frequencies may be appreciable. This is a matter to be considered seriously, especially if the harmonic frequency falls outside any of the bands assigned to amateurs.

The harmonics which are most often radiated are the second from transmitters employing single-tube output stages and the third from

Transmitter Adjustment

those employing push-pull output stages, although the fifth and higher harmonic frequencies have been known to cause trouble. Harmonic output is apt to be particularly high from output amplifiers using less than optimum values of tank-condenser capacity (See Chap. 5), driven with high excitation and feeding long-wire antennas which readily radiate harmonics.

Several measures may be taken to prevent the radiation of harmonics. Decreasing the $L-C$ ratio in the tank circuit of the driver when the driver is operating as a straight amplifier (not doubling) will reduce the harmonic con-

ductors are insulated, while at the other they are connected together. (Bib. 1).

R.F. Feedback Troubles

Occasionally it will be found on test with a neon bulb, or by other indication, that points, such as the chassis or transmitter frame, which should be at ground potential show considerable r.f. voltage. This usually occurs only with the antenna connected. One reason for this is that the antenna is not exactly the right dimensions for the frequency used, or the system is not tuned correctly and the antenna is attempting to "extend itself" to the correct length by adding in a portion of the power wiring etc. This condition is often responsible for abnormal interference with broadcast reception in the neighborhood. It is difficult to prevent this by grounding unless a very short ground wire is possible. The trouble is encountered more frequently with direct-coupled systems than with those using forms of inductive coupling. End-fed antennas are more susceptible to this form of trouble than symmetrical center-fed systems. Transmitters employing link antenna coupling or electrostatic shielding seldom exhibit this trouble. A line filter connected at the point where the power line enters the transmitter room will sometimes reduce the interference effects.

Sometimes it will be found that certain lights in the house will glow, even though switched off, when the carrier is turned on. This occurs most frequently when the building in which the transmitter is located is in the immediate inductive field of the antenna and where open unshielded wiring is used. If the effect is caused by resonance in some branch

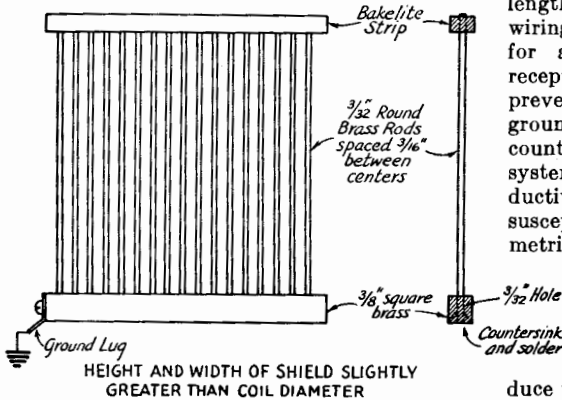

Fig. 1408 — Construction of the Faraday-type shield using brass or copper rods. The upper ends of the rods may be fixed to the bakelite strip with Duco cement.

tent of the excitation voltage and thereby reduce the harmonic output of the amplifier. Likewise, decreasing the $L-C$ ratio in the output amplifier tank circuit will reduce harmonic generation in this circuit.

Half-wave antennas fed by correctly adjusted low-impedance lines do not easily radiate harmonic energy.

Any form of inductive coupling between the output amplifier and the antenna system will discriminate against harmonics. Link coupling between the output-amplifier tank circuit and the antenna tuner is especially effective.

The capacity between a large antenna coupling coil and the tank coil of the output amplifier may be sufficient to provide a ready path for harmonic energy to the antenna system. This capacity may be nullified by the use of electrostatic shielding between the two coils. Fig. 1408 shows the construction of such a shield, while Figs. 1409 and 1410 illustrate the manner in which it is installed. The screen may also be made up using stiff wire instead of brass rod. The important point in the construction is that at one end the

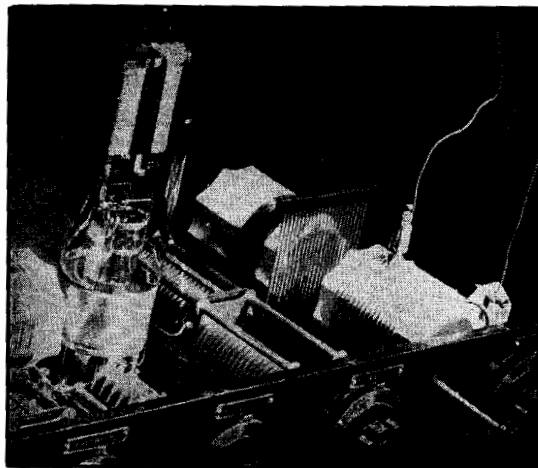

Fig. 1409 — Showing the manner in which the electrostatic shield is mounted between final tank and antenna coupling coils.

The Radio Amateur's Handbook

of the house-wiring, it is sometimes possible to detune the circuit with 0.01- μ fd. by-pass condensers across the affected lamps or by placing inductances in the line. If, as is more

usual, the effect is one of induction, the only remedy is to move the antenna.

Tuning Procedure

When all irregularities in a transmitting system have been ironed out, the tuning of a multi-stage transmitter is not at all difficult. The process should be started with the antenna disconnected or decoupled. Starting with the oscillator, each plate circuit is tuned for the characteristic dip in plate current and grid tanks, if used, tuned for maximum grid current. When different sections of the transmitter operate from separate power supplies, each power supply should be turned off until the stages operating from it are ready to be tuned. High-voltage stages should be tuned up at reduced plate voltage. Care should be taken in tuning doubler stages to pick the second harmonic of the driving frequency rather than the third harmonic which may also be within the tuning range of the tank condenser. When the final amplifier has been tuned to resonance, the antenna is coupled and tuned for maximum plate current. Tuning of the antenna may detune the output amplifier circuit and, therefore, retuning of the final tank should follow each adjustment of antenna tuning or coupling adjustment. If the plate current of the amplifier is higher than rated after retuning, the coupling should be reduced. If the plate current is not up to rating, the antenna coupling may be increased. Each adjustment of coupling should be followed with a check on the tuning of the final amplifier tank and the antenna tuner.

Coupling untuned lines will have less detuning effect than tuned lines if the system is correctly adjusted. Coupling adjustment in this case consists chiefly of increasing the coupling until the final amplifier draws rated plate current, although a final check should be made on the tuning of the output amplifier.

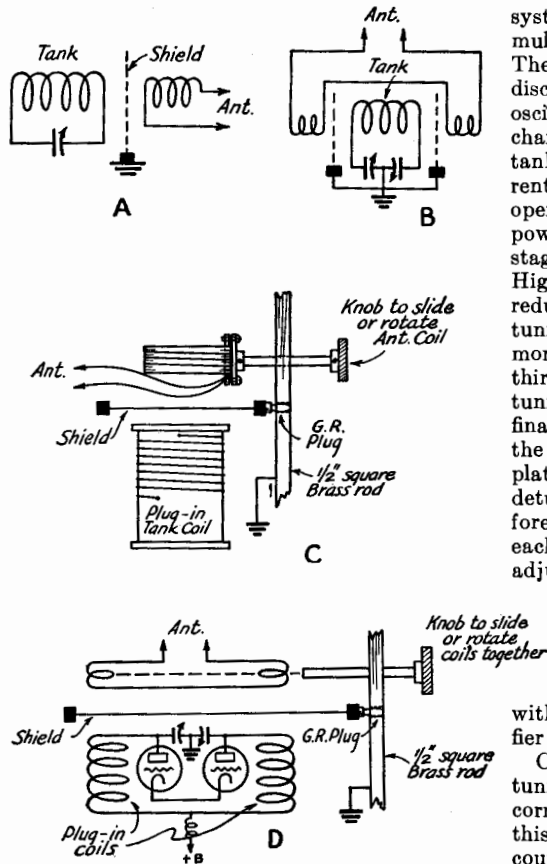

Fig. 1410 — Arrangements for using the shields with single-ended and push-pull circuits.

Bibliography

¹"About This Harmonic Radiation Problem," Woodward, *QST*, Feb. 1937; "Electrostatic Shielding in Transmitter. Output Circuits," Long, Priest, *QST*, March 1937.

Keying the Transmitter

Keying Systems — Key-Click Filters — Break In — Monitoring — Broadcast Interference

SATISFACTORY keying, from the standpoint of code-character formation, results if the keying method employed reduces the power output to zero when the key is "open" and permits full power to reach the antenna when the key is "closed." Furthermore, it should do this without causing keying transients or "clicks," which cause interference with other amateur stations and with local broadcast reception; and it should not affect the stability of the transmitter.

Back-Wave

From various causes some energy may get through to the antenna during keying spaces. The effect then is as though the dots and dashes were simply louder portions of a continuous carrier; in some cases, in fact, the *back-wave*, or signal heard during the keying spaces, may seem to be almost as loud as the keyed signal. Under these conditions the keying is hard to read. A pronounced back-wave often results when the amplifier stage feeding the antenna is keyed; it may be present because of incomplete neutralization of the final stage, allowing some energy to get to the antenna through the grid-plate capacity of the tube, or because of magnetic pickup between antenna coupling coils and one of the low-power stages.

A back-wave also may be radiated if the keying system does not reduce the input to the keyed stage to zero during keying spaces. This trouble will not occur in keying systems which cut off the plate voltage when the key is open, but may be present in grid-blocking systems if the blocking voltage is not great enough and, in power supply primary-keyed systems, if only the final stage power supply primary is keyed.

Choosing the Stage to Key

Radiation of a back-wave often can be prevented by keying a stage preceding the final amplifier.

If one of the early stages in the transmitter is keyed, the following stages must be provided with fixed bias sufficient to cut off plate current, or at least to limit the current to a safe value. Complete cut-off is preferable, since the possibility of back-wave radiation is reduced when no plate current at all is drawn by the

tubes following the keyed stage. The stability of the transmitter can be adversely affected by keying if the keyed stage directly follows the oscillator. Practically all oscillators, including crystal-controlled types, will exhibit some frequency change with changes in load. In a multi-stage transmitter the load on the oscillator is of course the input circuit of the following tube; for this reason it is good practice to have a buffer stage between the oscillator and the keyed stage. Electron-coupled or Tri-tet oscillators are less subject to this difficulty than straight self-controlled or crystal oscillators because of the buffering action of the separate output circuit used in these oscillators.

If the oscillator itself is keyed for break-in work, chirpy keying will nearly always result, especially on the higher-frequency bands. On 14 Mc. and above, therefore, it is normally advisable to forego oscillator keying (and break-in) for the distinctly better keying that will result from keying a buffer and/or final stage.

Plate Keying

A stage keyed in the power supply ahead of the filter is often advantageous, because the filter acts as a *lag* circuit, giving a desirable form to the keying characteristic. However, if much filter is used it will be found that the lag becomes too great for high-speed keying.

A simple method of plate keying, adaptable mainly in small portable transmitters where the voltage is not high, is that shown in Fig. 1501. The condenser C_1 should be varied to give just enough lag to overcome any tendency towards clicks. It is not advisable to use this system with high voltages unless a keying relay is employed.

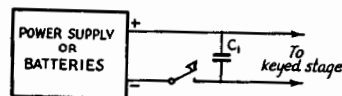

Fig. 1501 — Simple negative-lead keying, applicable to low-voltage stages. The condenser C_1 should be the minimum that will prevent any clicks. Between 0.25 and 1.0 μ fd. will be about right.

The Radio Amateur's Handbook

Primary Keying

Keying the primary of one or more plate transformers will result in excellent keying with no clicks or thumps on the signal, and only a small local click due to the spark at the key. This click is easily reduced by means of an r.f. filter (see Fig. 1515). However, if adequate filter is used on the power supply the keying will be too "soft" and the lag too great, and for this reason primary keying should be done in a driver stage, and *never* in the output stage. A driver stage, if it is *fully exciting* the driven stage, can have the filter reduced to a point where the keying will not be too soft and yet the excitation will not introduce much ripple on the signal.

Two methods of primary keying are shown in Fig. 1502. Each method requires a bias pack capable of delivering cut-off bias for the final stage. In the second method, since the final stage is biased to cut-off, the filter condensers of the final stage power supply will remain charged between characters, and care should be taken to see that these condensers are discharged when the station is shut down or coils are being changed. A high-resistance bleeder (R_2) of $\frac{1}{4}$ -megohm or so will discharge the condensers to a low point after a period of time without impairing the keying.

Controlled Rectifier Keying

The advantages of primary keying, with the additional advantage of not having to break a heavy current with the key or keying relay, can be obtained with the controlled rectifier tubes recently made available to amateurs. These tubes can be obtained with either grid-control or external magnetic control. They can be used for power-supply keying in the same fashion as primary keying (Fig. 1502) with the modification that where a primary was shown keyed, the rectifier tubes are keyed.

Representative grid-control keying circuits are shown in Fig. 1503, and a magnetic-control diagram is shown in Fig. 1504. (Bib. 1, 2)

Controlled-rectifier tubes cannot be used as keyer tubes in d.c. circuits but only in a.c. applications.

Since the current flowing from the rectifier into a condenser-input filter is pulsating d.c. that reduces to zero during each half of the cycle, a grid-controlled rectifier tube can be used to key between the rectifier and the first condenser of the filter. Such a system is shown in Fig. 1505. Here a single grid-controlled rectifier is used to key two stages, and the type of keying is quite similar to the lower system shown in Fig. 1502, and has the same general characteristics. (Bib. 3)

Grid Keying

Grid keying methods operate on the principle of controlling plate current flow through application of proper bias values with the key opened and closed. Two representative arrangements are shown in Fig. 1506. The upper drawing shows the key inserted in series with the grid leak or grid return circuit. With the key closed, the amplifier or oscillator operates normally; with the key open, there is no d.c. path between grid and filament, consequently the electrons drawn to the grid by the exciting voltage remain trapped on the grid causing it to assume a highly negative charge. The system works best with high- μ tubes: it may be found impossible to completely cut off low- μ tubes.

Another method of accomplishing the same result, in this case through supplying additional fixed bias of sufficient value to cut off plate current flow despite exciting, is shown in the lower drawing of Fig. 1506. Grid-leak bias for normal operation is shown, although a

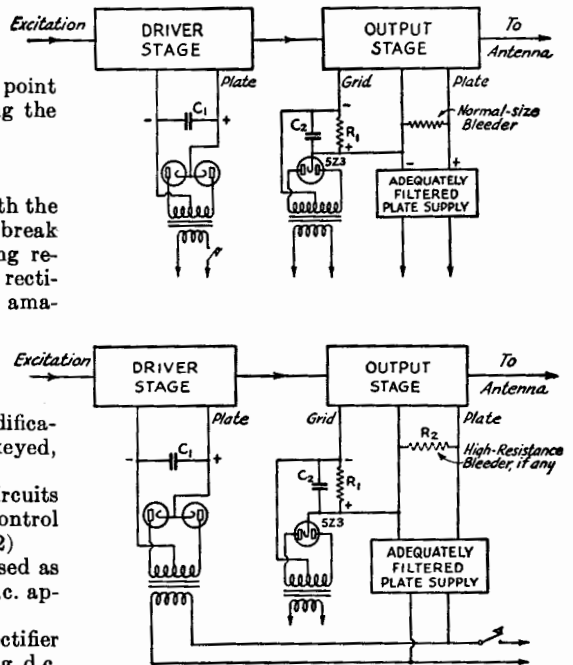

Fig. 1502 — Primary keying methods. The upper diagram shows only the driver stage keyed; the lower diagram shows keying of both driver and final stages. C_1 can usually be on the order of $1 \mu\text{fd.}$; higher values will introduce "tails." C_2 should have a voltage rating capable of withstanding the bias developed across R_1 , and should have a capacity of $4 \mu\text{fd.}$ or more. R_1 is the usual size of grid leak resistor for the tube or tubes used in the final stage, with a slightly greater-than-normal rating to withstand the extra current introduced by the bias supply.

Keying the Transmitter

battery or other bias source could be substituted for the leak. With the key closed, the lower end of the leak is connected to the filament center tap. When the key is opened, additional bias from the blocking-voltage source is connected in series with the leak through the resistor R . The chief function of R is to limit the flow of current when the key is closed, since without R the key would be a direct short circuit. The value of R is not critical but should be quite high — at least 5000 ohms for every 45 volts — to limit the current to a safe value. The additional bias voltage required to cut off plate current (or "block" the grid) will depend upon the amplification factor of the tube and the amplitude of the excitation voltage; it must at least be equal to the peak positive grid swing plus the bias required to cut off plate current without excitation. If the amplifier or oscillator is operating Class-C, the keying bias required probably will be two or three times the normal

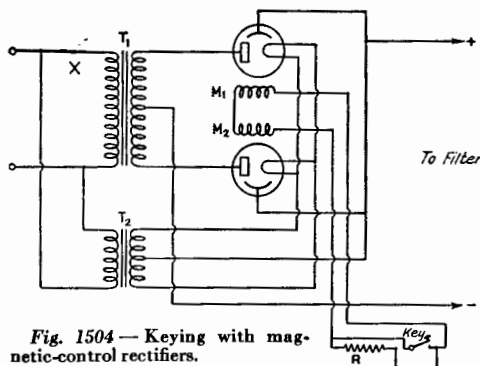

Fig. 1504 — Keying with magnetic-control rectifiers.
 R — 4000 ohms, 75-watt.
 T_1 — Plate transformer.
 T_2 — Rectifier filament transformer.
 X — Switch to allow preheating filaments.
 M_1, M_2 — Magnet coils, wound on U-shaped cores the ends of which are placed on either side of the tube. 5000 turns of No. 34 or 36 wire on a half-inch square silicon steel laminated core, approximately $1\frac{1}{2}$ " long on each side of the U (Raytheon U3372).

operating bias (twice cut-off). Smaller bias would serve for an amplifier with less excitation.

Grid-block keying systems are best adapted to stages using high amplification-factor tubes working without too much excitation.

Center-Tap Keying

A combination of both grid and plate circuit keying is shown in Fig. 1507. This method, known as center-tap keying, has attained wide popularity. In center-tap keying, one side of the key is connected to the midpoint of the filament center-tap resistor or to the center-tap of the filament transformer; the grid and plate returns connect to the other side of the key.

Center-tap or cathode keying gives an excellent keying characteristic but it has the disadvantage that considerable voltage can appear across the key, and a keying relay should normally be used.

Suppressor-Grid Keying

Keying the suppressor grid of a pentode-type tube usually will be found to be quite satisfactory. The plate current can be completely cut off by placing a small negative voltage on the suppressor grid — 100 to 200 volts is adequate in most cases. Fig. 1508 illustrates one method, using a separate power pack which supplies keying bias, that has been used in a number of stations with excellent results. With the key open, the suppressor receives negative bias through the 50,000-ohm resistor, the value of bias being adjusted to cut off plate current. When the key is closed, the suppressor bias is brought to zero through return to the cathode. The 50,000-ohm resistor pre-

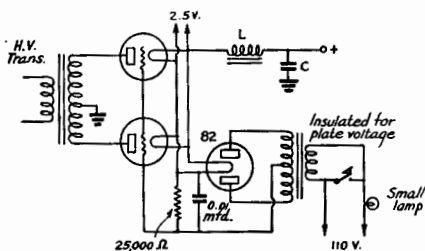
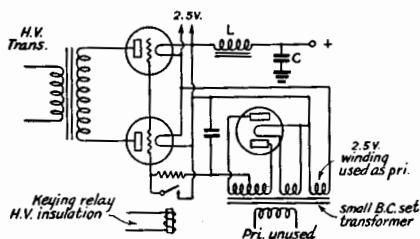
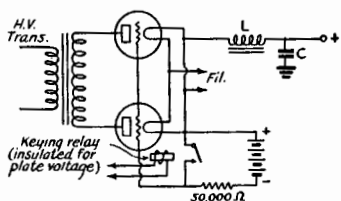

Fig. 1503 — Keying with grid-control rectifiers. The two upper systems require high-voltage-insulated relays for keying. These can be made easily from old trickle-charger automatic switches, with the contacts placed on bakelite outriggers. The contacts can be small because the current is negligible. The lower diagram shows a system requiring no relay but necessitating a well-insulated transformer. The voltage from the keying transformer should be 300 or more volts each side of center tap.

The Radio Amateur's Handbook

vents short-circuiting the bias supply. The combination of R_1 and C_1 forms a lag circuit for the elimination of clicks. The resistor and condenser can have practically any value, so long as their product (ohms times microfarads) is around 5000. It is not wise to have the value

zero, however, so screen keying is seldom used, although it has some application in oscillator keying, as will be described later.

Keyer Tubes

Vacuum-tube lag-circuit keying arrangements are shown in Fig. 1509. They may be used in the plate, screen-grid, or center-tap circuits of any amplifier which is to be keyed.

The time-constant of the resistance and capacity in the grid circuit of the keyer tube provides the slow build-up of power output which prevents clicks. The keyer tube has some resistance even though the grid is connected to the filament when the key is closed, so the plate voltage on the keyed stage will be lower than with other keying systems. To overcome this, several tubes may be connected in parallel. The 2A3 or 45 type tubes are excellent for low-power transmitters because their plate resistance is low. One tube can be used for each 50 ma. of plate current required by the tube being keyed.

The filament transformer for the keyer tubes need not be center-tapped: in fact, the tubes may be connected in series if desired.

Tube keying is used in a large number of commercial high-speed transmitters and is well worth investigating by the serious amateur interested in good keying.

Sources of Bias

If a multi-stage transmitter is keyed in one of the low-power stages, it is necessary to bias the following stages so that they will not

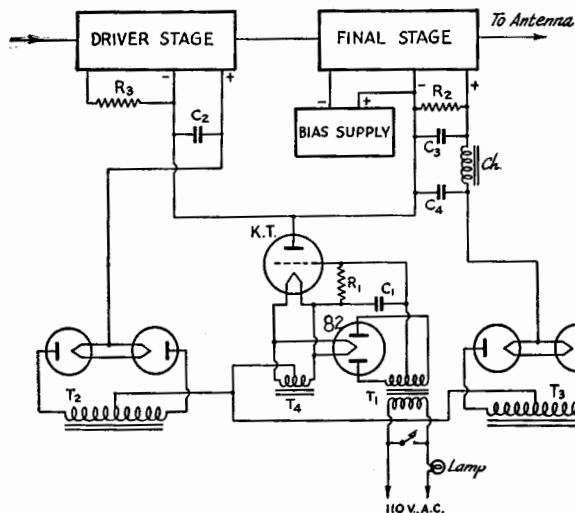

Fig. 1505 — A method of applying a single controlled-rectifier to multi-stage keying.

T₁ — Bias transformer, 300-volt each side, low current, insulated for total plate voltage.

T₂ — Driver plate transformer.

T₃ — Final plate transformer.

T₄ — Keyed-rectifier filament transformer. 2½-volt, 10,000-volt insulation.

KT — Controlled rectifier tube. (Eimac KY-21 or Sheldon KY-866.)

C₁ — .25 μfd., 600-volt paper.

C₂ — 1 μfd. if driver uses high voltage and low current; 2 μfd. if driver takes low voltage and high current.

C₃, C₄, Ch — Final amplifier filter.

R₁ — 50,000-ohm, 2-watt carbon.

R₂ — 1-3 megohm, or high-voltage voltmeter.

R₃ — Driver stage grid leak.

of resistance too high, however. From 5000 to 10,000 ohms is about right. The power pack can also be used to supply bias voltage for the following stages.

Screen-Grid Keying

Screen-grid tubes often can be keyed by inserting the key in the positive screen lead, especially when the screen voltage is obtained from a supply separate from that furnishing the plate power. If the screen voltage is obtained from the plate supply through a dropping resistor, this method of keying is unsafe with high-voltage tubes unless a keying relay is used, because the potential on one side of the key rises to the full plate potential when the screen current is cut off. Opening the screen circuit does not always reduce the output to

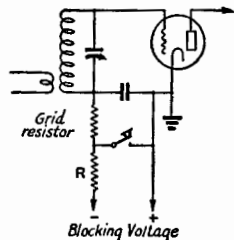
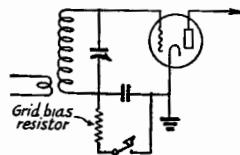

Fig. 1506 — Methods of blocked-grid keying. These systems are normally suitable only for high-μ tubes.

Keying the Transmitter

draw plate current with the key up. A simple a.c. power supply is ordinarily used for this purpose, although batteries can be substituted. The grid leak resistor will be placed across the output of the bias supply and, in cases where large amounts of grid current are drawn at fairly low voltages (low resistance grid leak), the bias supply must run at fairly heavy current. For example, if the final amplifier is to run with 400 volts bias at 100 ma., a grid leak of about 4000 ohms will be used. But if the cut-off bias is 200 volts, the grid resistor will draw 50 ma. from the bias supply. This relatively heavy drain must always be considered when building a bias supply. Also, the grid leak resistor must be heavy enough to stand the current and the filter condensers

ment circuits of the tubes working from the two supplies cannot be connected together. The condenser *C* serves to put all cathodes at the same r.f. potential without direct connection between them. Resistor *R* limits the current when the key is closed, as already explained. A value of 50,000 ohms will suffice for a low-voltage supply of 400 volts or so. It should have a rating of about 5 watts.

Oscillator Keying

Experience with keyed oscillators has shown that the use of a voltage divider instead of a simple series resistor for the screen of the oscillator tube helps materially in eliminating chirps. Cathode keying of the oscillator is simple and usually effective. Two methods of keying in the cathode circuit are shown in Fig. 1511, and screen-grid keying is shown in Fig. 1512. The suppressor-grid of a Tri-tet oscillator may be keyed, as in Fig. 1508, but the crystal will oscillate weakly all of the time, as in the case of screen-grid keying, resulting in a signal in the receiver on the crystal frequency even with the key in the "open" position. For this reason, screen-grid and suppressor-grid oscillator keying are not recommended for net-frequency operation unless the transmitter is well-removed from the receiving location.

Crystal keying can also be used to advantage, and two typical circuits are shown in Fig. 1513.

If it is found difficult to key an oscillator without a chirp, loosening the loading on the oscillator may cure it. If it is a pentode-type oscillator, the capacity of the tuning condenser should be decreased slightly instead of running the tube at its maximum output point. Decreasing the capacity of the cathode condenser will help in the case of a Tri-tet oscillator.

If an electron-coupled oscillator chirps under keying, it may be that the grid-circuit tank utilizes too low-*C* a circuit, and taking turns off the coil and increasing the condenser size will help. Detuning the plate circuit will also contribute to the stability, as will careful proportioning of the screen and plate voltages. A major cause of poor e.c.o. stability is incomplete shielding from the high-powered portion of the transmitter, and it is advisable to remove the e.c.o. from the transmitter proper and place it in a well-shielded box on the operating table if any chirp persists. Link coupling, with one side of the link-line grounded, can be used between the e.c.o. and the transmitter.

Key Clicks and Thumps

When power is applied or removed from the transmitter very suddenly, as in the

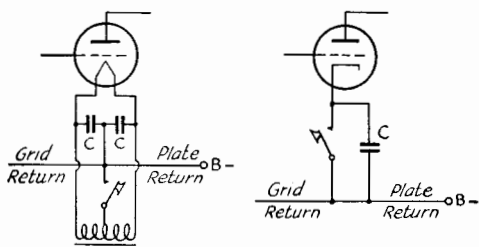

Fig. 1507 — Center-tap keying. Keying for filament type tubes is shown at the left and for cathode types at the right. The by-pass condensers, *C*, should be about 0.001 μ f. and capable of withstanding full plate voltage. They are necessary to furnish an r.f. return to ground. Full plate voltage appears across the key, so a relay should be substituted for the key if high voltages are used.

must have a high-enough voltage rating to stand the full bias voltage.

If the bias supply is to be used only for keying, as in the case of grid-block or suppressor-grid keying, a very small b.c. transformer may be used, its only requirement being that it furnish sufficient voltage. (Bib. 4)

It is possible to obtain keying bias without extra cost from the power supply used for low-power stages in multi-stage transmitters, when the keyed stage has its own separate supply. This can be done as illustrated in Fig. 1510. Since this entails connecting the positive terminal of the low-voltage supply to the negative terminal of the high-voltage supply, the fila-

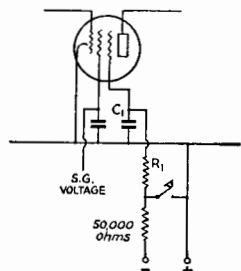

Fig. 1508 — Suppressor-grid keying. The condenser *C*₁ can be the usual 0.01- μ f. by-pass shunted by a larger condenser to give the proper time-constant.

The Radio Amateur's Handbook

case of keying, it is the same as though the transmitter were being modulated by a signal which contains a great number of different frequencies, with the result that the sidebands can extend for many kc. either side of the transmitter frequency, at the instant that the power is applied or removed. The signal that

frequencies within a few kilocycles of the transmitting frequency. In other words, key clicks are likely to be observed on only those broadcast receivers located within a hundred yards or so of the transmitter, but may cause interference to amateur stations hundreds of miles away working in the same portion of the same band. Obviously it is to the interests of the amateur himself to prevent key clicks, not only because of a possible unfavorable reaction on the part of nearby broadcast listeners but also to prevent unnecessary interference in the amateur bands.

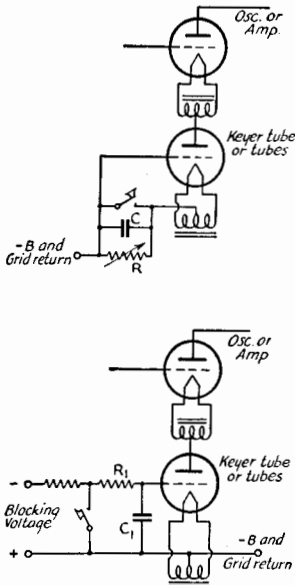

Fig. 1509 — Vacuum-tube keying. The series method is simple but does not completely cut off the current flow. It may be used in some applications where the following stage is heavily biased. C may be between 0.25 and 1.0 μfd . Resistor R should be adjusted to cause the plate current to drop to a minimum when the key is open. A variable resistor of 50,000 ohms should give enough range.

The system with external bias is very effective. R_1 and C_1 give the variable time-constant, and should be proportioned as described under suppressor-grid keying, except that the resistance can be a much higher value, with the capacity correspondingly lower.

is heard off the main frequency is the familiar "key click" or "key thump" that many stations are guilty of. It is caused by the steepness of the wave-front of the applied power.

Another type of click that can only be heard locally and does not necessarily appear on the transmitted signal is caused by the spark at the key, where the spark acts as a miniature spark transmitter. With some types of keying, the r.f. generated at the key can get back to the transmitter and modulate the transmitter. This type of trouble can easily be eliminated by means of a small r.f. filter at the key.

Because the amount of energy involved is small and is distributed over a wide band of frequencies, the interference-producing effects of keying transients usually are confined to an area quite close to the transmitter except on

Prevention of Key Clicks

There are two general methods of attack in preventing keying transients. The first is by feeding the power to the transmitter at a comparatively slow rate on closing the key and shutting it off gradually instead of suddenly on opening the key. The second is by the use of radio-frequency filters which absorb the transient before it can get to a part of the circuit from which radiation is possible. Both methods have been very successful.

Lag Circuits

Three representative lag circuits are shown in Fig. 1514. The one shown at B is a more complex version of the one shown at A , and can be tried in hard-to-cure cases. That at C is a novel system that has worked well in several cases.

Lag circuits should be used in keying when it is found that the signal itself has a thump or click on it, as reported by other amateurs. A click in local b.c. receivers may often be caused by only the spark at the key and can be cured by a simple r.f. filter.

R.F. Filters

With an r.f. key filter the transient oscillations set up at the key are prevented from reaching the transmitter and being radiated. To be most effective, this type of filter must be installed right at the key, since connecting

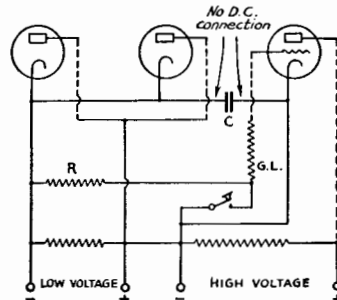

Fig. 1510 — Utilizing the low-voltage power supply for blocking bias in blocked-grid keying. C should be 0.002 μfd . or so.

Keying the Transmitter

leads of even a few feet between key and filter are long enough to permit radiation of clicks and consequent interference to nearby receivers.

An r.f. key filter usually consists of a pair of r.f. choke coils having an inductance of ten millihenrys or so, connected in series with each of the key contacts and shunted by a condenser as shown in Fig. 1511. The condenser ordinarily will have a capacity of 0.1 to 0.5 μ f. As with the lag circuit, some experimenting with different inductance and capacity values probably will be required for effective elimination of clicks in individual transmitters.

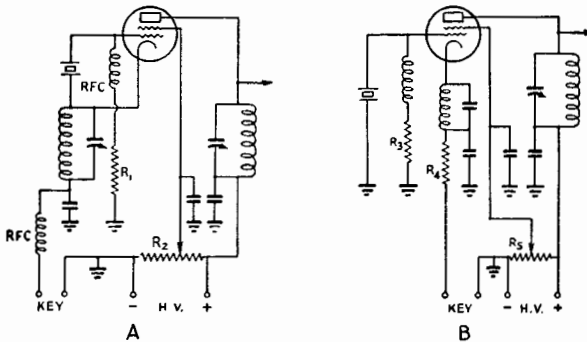

Fig. 1511 — Cathode keying for tri-tet oscillator. Typical values for 6L6: R_1 — 50,000 ohms; R_2 — 20,000 ohms. B — Cathode keying for grid-plate oscillator. Typical values for 6L6: R_3 — 50,000 ohms; R_4 — 400 ohms; R_5 — 20,000 ohms.

Parasitics and Key Clicks

If it is found that the use of standard key click filters has little or no effect upon clicks, an investigation should be made to determine if parasitic oscillations are taking place in any of the transmitter circuits. In any case, it should be possible to adjust the bias of any amplifier so that some plate current is drawn without the amplifier going into oscillation.

Self-oscillations have a tendency to start each time the key is closed, resulting in bad key clicks even though the oscillation is immediately killed off by excitation.

Other Considerations in Key Click Prevention

Less trouble will be encountered in eliminating key clicks if the power supply for the keyed stages has good voltage regulation (see Chapter Eleven). If the voltage regulation is poor, the plate voltage with the key open may be 50% to 100% higher than with the key closed; hence, at the instant of closing the key there is an impact at much higher than normal voltage. This intensifies the key click.

Key clicks are less likely to be radiated if the antenna or feeder system is inductively coupled to the transmitter rather than directly or capacitively coupled. A considerable reduction in key clicks often can be secured simply by changing a non-inductively coupled system to an inductively coupled one with little stray capacitive coupling.

It is always desirable and in some cases may be necessary to run the 110-volt leads to the transmitter in BX cable, grounding the outer shield. Shielding of the keying leads also may be helpful, especially if a long line is run between the transmitter and the key. Whenever shielded wire is used the shield should be connected to a good ground.

To prevent keying transients from being carried over house wiring and power lines from the transmitter to nearby receivers, a filter may be installed in the 110-volt line which feeds the power transformers. Such a filter is shown in Fig. 1516. It consists of a pair of radio-frequency choke coils, one in each leg of the line, and a pair of condensers in series

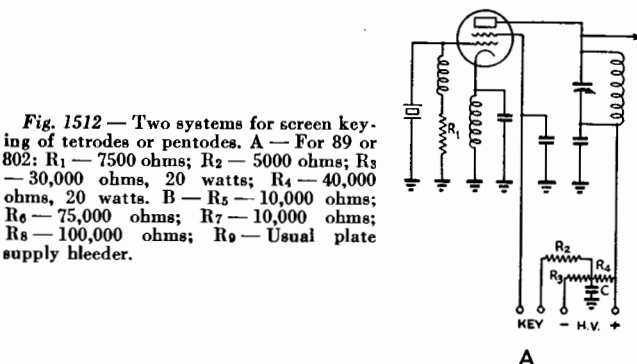

Fig. 1512 — Two systems for screen keying of tetrodes or pentodes. A — For 89 or 802: R_1 — 7500 ohms; R_2 — 5000 ohms; R_3 — 30,000 ohms, 20 watts; R_4 — 40,000 ohms, 20 watts. B — R_5 — 10,000 ohms; R_6 — 75,000 ohms; R_7 — 10,000 ohms; R_8 — 100,000 ohms; R_9 — Usual plate supply bleeder.

The Radio Amateur's Handbook

across the line with their mid-connection grounded. These filters are commercially available in most radio stores, but can easily be assembled in the home workshop.

The wire of which the chokes are wound must be heavy enough to carry the current taken by the power-supply system. No. 14 or No. 16 will be sufficient in most cases. Mailing tubes or pieces of broomstick make good

series if not too much grid current is run through them, or a bias supply can be built for the purpose. The grid-block system for keying an entire transmitter, shown in Fig. 1517, has the merit that all stages are blocked when the key is up, and a low-current bias supply can be used. The voltage obtained from the supply must be at least equal to the cut-off voltage of any tube in the transmitter.

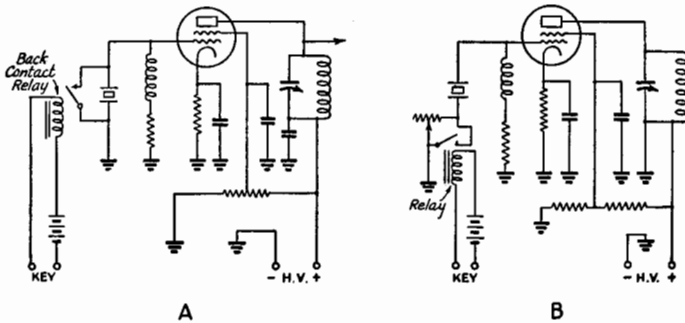

Fig. 1513 — Crystal keying circuits.

winding forms for these chokes. Between 100 and 300 turns will be required. The condensers may be 0.1- μ fd. units rated at 200 volts or more.

Break-in Keying

The possession of a transmitter that can be used for break-in operation is practically a necessity in traffic and contest work and is a great convenience in everyday operating and rag-chewing. Break-in operation requires that there be no local signal from the exciter stages when the key is up, and therefore oscillator keying followed by biased stages is dictated, except in the few instances where it is possible to locate the transmitter a mile or more from the receiving location. Any of the keying systems described can be used to key a crystal or electron-coupled oscillator, but care must be taken to see that the stability of the signal is not affected. The bias for the stages following the oscillator can be obtained from bat-

Monitoring

It is a distinct advantage to be able to listen to one's own sending during transmission periods, particularly when a "bug" key is used at high speeds, because it is easy to get into careless habits of running letters together and getting too many dots in some of the letters. A *signal monitor* checks both keying and note by giving an accurate representation of the signal, while a *keying monitor* works in conjunction with the key and shows only how the characters are being sent. A signal monitor must be stable and insensitive to line-voltage changes, otherwise it will not give an accurate picture of the signal if keying the transmitter fluctuates the line voltage. Signal monitors are described in Chapter Seventeen. Often the station receiver can be used as a signal monitor, by shorting or disconnecting the antenna, backing down the gain and tuning to the signal, but this is often inconvenient and a separate monitor is more practical.

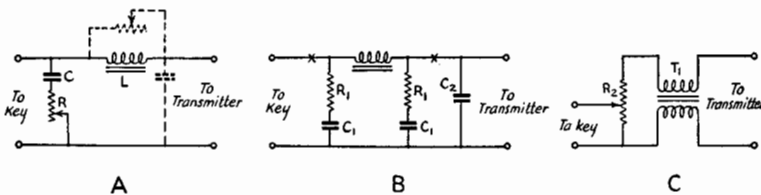

Fig. 1514 — Lag circuits for eliminating thumps and clicks. The primary of a bell-ringing transformer will usually serve at L in low-powered transmitters.

C — 0.25 to 1.0 μ fd. C₂ — 0.006 μ fd. R₂ — 500-25,000 ohms.
 C₁ — 0.5 μ fd. R — 50-200 ohms. T₁ — Bell-ringing transformer.
 R₁ — 100 ohms.

Radio-frequency chokes may be necessary at "x" in B.

Keying the Transmitter

Keying monitors can be any simple audio oscillators which obtain their plate voltage from the drop across a resistor in one of the power leads of the transmitter. Since no current flows from the power supply to the transmitter during "key up" periods, plate voltage will be silent until the key is pressed, at which time the voltage drop across the resistor will

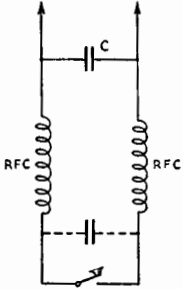

Fig. 1515 — An r.f. filter for the absorption of keying transients. It is ordinarily used without a condenser directly across the key. However, an improvement sometimes results when a condenser of about .002 μ fd. is connected as shown by the dotted lines.

actuate the monitor. An audio oscillator suitable for use as a keying monitor is diagrammed in Fig. 1518. It is more convenient and safe to use battery supply for the filaments and a loud speaker for listening than it is to try to feed the signals into the headphones. The resistor R_1 will control the pitch of the signal; R_3 should be adjusted so that the drop across it is approximately 30 volts. If the current through the lead is known, the value of the resistor will be given by

$$R = \frac{30,000}{I}$$

where I is the current in milliamperes. For example, if the current is 100 milliamperes, the resistor should be 300 ohms.

Interference to Broadcast Reception

Key clicks and thumps are not only a source of annoyance to other amateurs working in the same frequency band and a mark of a careless amateur, but they can also be responsible for considerable interference to nearby broadcast receivers. A second type of interference, called "blanketing" because it causes the program to disappear or come in at reduced strength whenever the key is closed, also is common. This type of interference can be minimized by moving the broadcast antenna away from the transmitting antenna or by changing its direction. The pick-up will be least if the two antennas are at right angles to each other.

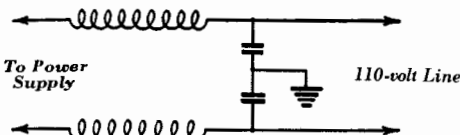

Fig. 1516 — R.f. filter for the power line.

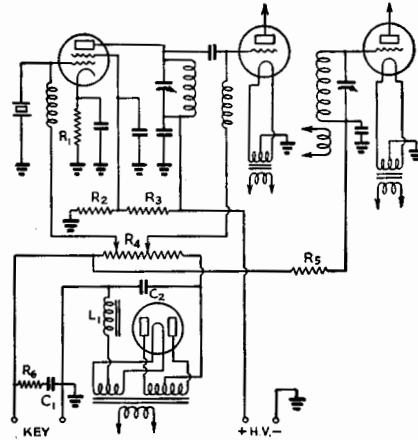

Fig. 1517 — Blocked-grid keying system for break-in. R_1, R_2, R_3 — Usual values; R_4 — 20,000 ohms, 50 watts; R_5 — Final stage grid leak.

In severe cases it may be necessary to install a wave-trap at the receiver to prevent blanketing. A wave-trap consists simply of a coil and condenser connected as shown in Fig. 1519. The condenser may be an old one with about 250 or 360 μ fd. maximum capacity and need not be especially efficient. Most amateurs have "junk boxes" with several such condensers in them. The size of the coil will depend upon the frequency on which the transmitter is working. Representative values are given in the table.

Frequency of Interfering Signal	Coil (3" dia.)
1715-2000 kc.	20 turns
3500-4000 kc.	8-10 "
7000-7300 kc.	4-5 "
14000-14400 kc.	3 "

Bell wire (No. 18) or a size near to it may be used. When the trap is installed the trans-

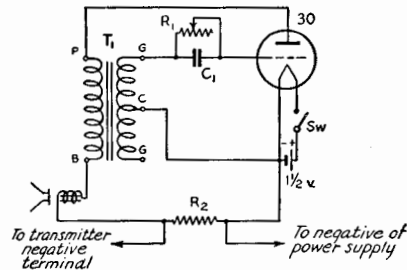

Fig. 1518 — An audio-oscillator keying monitor.

- C_1 — 0.01 μ fd., 600-volt paper.
- R_1 — 5-megohm variable.
- R_2 — 300 ohms for 100-ma. plate current; 600 ohms for 50-ma. plate current, etc., 2-watt. (See text.)
- T_1 — Midget audio transformer (Thordarson T-14A92).
- S_w — S.p.s.t. toggle.
- Speaker can be small permanent-magnet speaker, 3" or so.

The Radio Amateur's Handbook

mitter should be started up and the condenser in the trap adjusted to the point where the interference is eliminated. This trap will not affect the operation of the broadcast receiver.

Blanketing may be and generally is accompanied by key clicks. The wave trap may help to eliminate the clicks but usually a key click filter will be needed as well.

Low-Pass Filters for Blanketing

The chief disadvantage of the wave-trap is that it has to be retuned if the transmitting frequency is changed from one band to another,

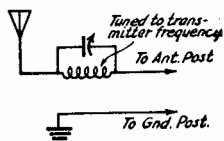

Fig. 1519—How a wave-trap can be installed to prevent certain types of interference.

and sometimes also if the frequency change is only from one end to the other of the same band. In such cases a better arrangement is the low-pass filter, designed to reject all received frequencies except those below a certain critical frequency. If the critical frequency is chosen just below the lowest amateur frequency used, the transmitter can be shifted from one band to another without the necessity for readjustment of a wave trap. A typical low-pass filter is shown in Fig. 1520. The constants given are for a cut-off frequency of 1600

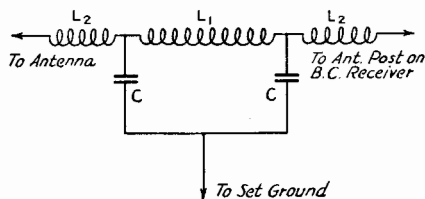

Fig. 1520—A low-pass filter for reduction of interference with broadcast reception. It should be installed at the receiver. Constants are as follows: L_1 , 54 turns of No. 24 d.s.c. on $1\frac{3}{8}$ -inch diameter form; L_2 , 33 turns same; C , 500 $\mu\text{fd.}$ fixed. Cut-off frequency is approximately 1600 kc.

kilocycles. The filter is designed for terminating impedances of 400 ohms.

Another type of filter which has a sharper cut-off than the one just described is shown in Fig. 1521. This is of particular advantage for 'phone stations operating in the 1800- and 3900-kc. bands, since maximum attenuation is in the middle of those bands, the nominal cut-off being somewhat lower. The type A filter has greatest attenuation at 1930 kc., with cut-off beginning at 1670 kc. Type B has greatest attenuation at 3950 kc., with cut-off beginning at 2470 kc. The type A is recommended for work in several bands.

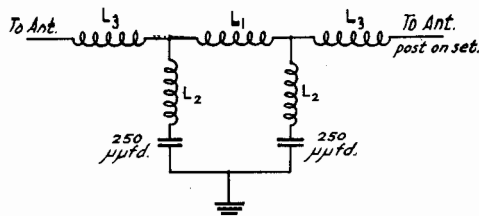

Fig. 1521—Circuit diagram of sharp cut-off low-pass filter.

Type	Inductance in Microhenries		
	L_1	L_2	L_3
A	38	28	19
B	40	6	20

Coil Specifications		
Microhenries	Turns	
6	10	No. 28 d.s.c. wire
19	18	" " "
20	19	" " "
28	24	" " "
38	29	" " "
40	30	" " "

Coils wound on $1\frac{3}{8}$ "-diameter form.

Superheterodyne Harmonics

A third type of interference is peculiar to superheterodyne broadcast receivers. A strong signal from the transmitter will be heard at three or four points on the dial, while over the rest of the tuning range there may be no sign of interference. The explanation lies in the fact that the transmitted signal is picked up by beating with harmonics of the superheterodyne oscillator and amplified by the i.f. stages in the receiver. If the receiver is properly shielded and the oscillator is isolated from the antenna circuit, the signal cannot get into the oscillator circuit to be mixed with its harmonics and this type of interference cannot occur. When it *does* occur the fault does not lie with the transmitter but with the broadcast receiver. A wave-trap may help if the transmitter signal is brought into the receiver through the antenna, but in some cases the pick-up is direct and the interference is just as strong whether the antenna is connected to the receiver or not.

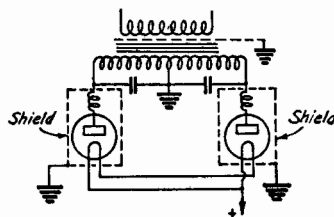

Fig. 1522—Devices for eliminating noise from mercury-vapor rectifier tubes. The r.f. chokes in series with each plate should be placed inside the shields enclosing the rectifiers. The chokes should have an inductance of about 10 millihenrys each. Small honeycomb-type windings are suitable. Condensers of 0.002 $\mu\text{fd.}$ and 150% voltage rating should be used.

Keying the Transmitter

Often interference of this type with a nearby receiver can be eliminated by changing the operating frequency of the transmitter. (Bib. 5).

Rectifier Noise

Mercury-vapor rectifiers often are the source of a peculiar type of interference which takes the form of a raspy buzz with a characteristic 120-cycle tone (100 cycles on 50-cycle power lines and 50 cycles on 25-cycle lines) often broadly tunable in spots on the broadcast receiver dial. At the instant the mercury vapor ignites on each half cycle of the power frequency an oscillation is set up, the frequency depending upon the characteristics of the power supply apparatus. Unless suitable precautions are taken the oscillations will be radiated or will travel back over the power line.

The line filter shown in Fig. 1516 usually will suppress this type of noise. Sometimes the condensers alone will do it, no chokes being necessary. Transformers with electrostatic shields between primary and secondary are not likely to transmit the oscillations to the line. Other ways of curing this type of interference are shown in Fig. 1522. Sometimes making the plate leads to the rectifiers extremely short will be sufficient.

Checking for Interference

One's own broadcast receiver, if of modern design, is a good "subject" for experimenting with key click filters and other interference-prevention methods. If interference can be eliminated in a receiver in the same house, operating from the same power line and with an antenna close to the transmitting antenna, the chances are good that there will be no general interference in the neighborhood. The amateur should ascertain, however, whether or not interference is caused in nearby broadcast receivers. If your neighbors appreciate that you are as much interested in preventing interference to their enjoyment of broadcast programs as they are, much more can be accomplished than by acrimonious disputes. It is better to settle the interference problem right at the beginning than to trust to luck with the possibility of an unfavorable reaction towards amateur radio in general and yourself in particular by nearby broadcast listeners.

In searching for causes of interference, it is a good idea to have someone operate your transmitter while you listen on the affected receiver. Remove the antenna from the receiver, and if

the interference disappears it is certain that it is coming into the set through the antenna. The various types of interference prevention already described should work under these conditions. If the interference persists when the antenna is removed, it is probably getting in through the power lines. This happens occasionally with a.c. operated receivers.

House wiring may pick up r.f. either directly from the antenna or through the power-supply system of the transmitter. If the 110-volt line is found to be picking up energy directly from the antenna it is advisable to change the location of the antenna, if possible, or run it in a different direction. This is particularly important when, as often happens, electric lamps in different parts of the house are found to glow when the key is pressed. The energy used in lighting the lamps is wasted.

If r.f. is found to be getting into the line through the power-supply, a line filter such as is shown in Fig. 1516 should be used, together with power leads in grounded BX.

Radiotelephone Interference

Key-click filters are naturally of no value on transmitters used exclusively for 'phone transmission, since clicks do not occur. A phenomenon similar to key clicks can take place if the transmitter suffers from frequency modulation or from over-modulation, because both these defects cause the radiation of side-bands often far removed from the band of frequencies normally required for the transmission of speech. These abnormal side-bands can and frequently do cause interference in the broadcast band, often just as a series of unintelligible noises when the transmitter is modulated. The obvious remedy is to use a radio frequency system in the transmitter whose frequency does not vary when modulation is taking place, and to adjust the transmitter so that over-modulation or "lop-sided" modulation does not occur. Chapter Sixteen covers this subject.

Blanketing and other forms of interference caused by r.f. pickup can be treated in exactly the same way as described previously. Wave-traps or low-pass filters in the receiving antenna lead-in and r.f. filters in the power lines will prove effective in eliminating this type of interference.

Bibliography

¹ *QST*, February, 1938, page 34. ² *QST*, September, 1938, page 42. ³ *QST*, January, 1939, page 31. ⁴ *QST*, September, 1938, page 30. ⁵ *QST*, September, 1937, page 12.

Adjustment of 'Phone Transmitters

Procedure for Various Modulation Systems — Checking Modulation Percentages and Linearity — Use of Oscilloscope — Trouble Shooting — Eliminating Broadcast Interference

A 'PHONE TRANSMITTER built of the best parts obtainable, combined according to good design practice, may emit badly distorted interference, creating hardly intelligible signals if operated with improper adjustment. If the quality of the modulation of a 'phone station is a factor in the number of contacts and the results obtained — and there is no doubt that this is true — an inexpensive low-power transmitter combining good design with proper adjustment is far more effective and satisfactory than one of much higher power but poor adjustment and consequent high distortion.

The general requirements for proper adjustment are common to 'phone transmitters employing the different methods of amplitude modulation discussed in Chapter 6. These requirements include:

1. Impedance match of modulator to modulated amplifier.
2. Linearity of modulated amplifier.
3. Avoidance of over-modulation.
4. Prevention or elimination of r.f. feedback into audio amplifier.

In addition to meeting these considerations, the transmitter must be capable of modulation without any change of carrier frequency. Design of the r.f. section for freedom from unintended frequency modulation is discussed in Chapter 5.

● ADJUSTMENT OF PLATE-MODULATED TRANSMITTERS

For simplicity of adjustment to proper operating conditions, the plate-modulated 'phone transmitter is unexcelled. In the most usual case, a c.w. transmitter is provided with a Class B or Class AB modulator capable of sine-wave audio output equal to half the power input at which the modulated amplifier is to be operated. The only circuit change of the r.f. portion of the transmitter is insertion of the secondary winding (or a portion of the secondary in the case of a multi-impedance trans-

former) of the modulation transformer in series with the plate supply connection of the final amplifier. The impedance which the modulation transformer must match is the value obtained by dividing modulated amplifier plate voltage (volts) by mod. amp. plate current (ma.) and multiplying by 1000, as explained in Chapter 6.

Correct grid bias voltage for the modulated amplifier may be as much as three multiplied by the correct bias for the same stage and same plate voltage with c.w. operation, as specified in the manufacturers' tube tables. The latter source, or the tube tables given elsewhere in this book, should be consulted for correct operating bias with plate modulation. An 809, for instance, should be given 160 volts negative bias for 'phone operation at 500 or 600 volts plate, while the same tube requires only 50 volts and 60 volts, respectively, negative bias for telegraph operation at 500 and 750 volts.

Correct r.f. excitation power for a modulated amplifier, also, may be as great as three times enough grid driving power for c.w. operation. Some c.w. transmitters, however, are normally operated with much higher excitation than the minimum required value, so that in some cases no increase of driving power is necessary. If the excitation power is sufficient to cause a grid current value equal to or slightly greater than the value specified by the tube tables for plate-modulated operation at the specified grid bias, no increase of r.f. grid driving power need be made for a good 'phone.

One other factor in the capability of an r.f. amplifier to be plate modulated properly is the necessity for complete neutralization, in the case of triode amplifiers. An imperfectly-neutralized amplifier is likely to be non-linear.

If the transmitter meets the requirements given in the three above paragraphs, and if variations of plate voltage in the amplifier to be modulated do not affect the frequency of the r.f. oscillator, the amplifier is properly suited for plate modulation. Of course, plate tank condenser spacing and circuit insulation

Adjustment of 'Phone Transmitters

must be adequate for the high peak voltages applied to the amplifier.

Modulation Limit

With amplifier operating conditions correct for 'phone, and with the modulator output matched as closely as possible to the modulating impedance of the r.f. amplifier as described in Chapter 6, the next step is to determine the actual percentage of modulation under normal operating conditions. The amateur regulations require that the transmitter not be modulated more than 100%, or in excess of its modulation capability. The modulation capability depends upon the linearity of the modulated r.f. amplifier and the amount of audio power available from the modulator, and will be 100% for properly designed and adjusted transmitters.

For amplitude-modulated transmitters (considered exclusively in this chapter) the most satisfactory modulation indicator is a cathode-ray oscilloscope. Continuous checking by means of an oscilloscope is a highly-desirable way of making certain that modulation peaks are being kept within the 100% limit. However, in case an oscilloscope is not available simpler means may be used. For example, the plate-current meter of a Class-B modulator can be used as a modulation indicator, once the average meter reading with 100% voice modulation has been determined. Making this measurement usually will require an oscilloscope, which may be borrowed for the purpose from an amateur or serviceman friend, but the check need be made only once so long as the operating conditions (r.f. amplifier plate voltage and current, modulator plate voltage) remain unchanged. The speech amplifier gain should be set to keep the modulator plate current within the reading so found.

Negative-Peak Overmodulation Indicators

With perfect 100-per cent plate modulation, the alternating output voltage of the modulator, in series with the r.f. amplifier plate supply d.c. output, reduces the r.f. amplifier plate voltage to zero on negative peaks and increases it to twice the amplifier d.c. supply voltage on positive peaks. If the audio output voltage is further increased (causing overmodulation) the voltage applied to the r.f. amplifier plate circuit becomes slightly negative on negative peaks, and more than twice the d.c. supply voltage on positive peaks. If a meter or other current indicating device is placed in series with a rectifier which allows current to flow through the indicator only when the voltage applied to the modulated amplifier plate circuit is negative with respect to ground, negative overmodulation peaks will be indicated. Such a device may be made to indicate peaks at 80 or 90 per cent modulation rather than above 100 per cent, if desired, by making the positive connection of the negative-peak indicator to a voltage-divider point a few volts positive with respect to ground.

A diagram of a negative-peak modulation per cent or overmodulation indicator combining advantages of simplicity, completeness, effectiveness, and economy, is given in Fig. 1601. This unit may be set to indicate modulation up to 100 per cent; in other words, to give a warning signal when a peak of a predetermined amplitude up to 100 per cent is reached in the modulation.

In Fig. 1601, R_1 is the bleeder across the power supply of the modulated amplifier, while R_2 is a potentiometer in parallel with the portion of R_1 between ground and the adjustable tap. R_2 serves two purposes — that of a vernier control on the portion of R_1 used, and that of a convenient method of adjusting from the front of panel the tap from the audio transformer primary for the proper voltage above ground on the modulated amplifier plate supply. T_3 is an audio transformer with primary connected in series with a rectifier between the modulated amplifier B + connection and the adjustable tap on R_2 . The polarity of the rectifier tube connections is such that the voltage at the B + connection of the amplifier must be negative with respect to the voltage of the R_2 tap to cause a warning flash of the modulation indicator. This indicator, a simple neon bulb with resistor removed from the base, is shown connected across the secondary of the audio transformer.

If the tap on R_1 is set at a point one-fourth the distance from the ground end, the control R_2 may be used to set the modulation percentage for indications at any value between

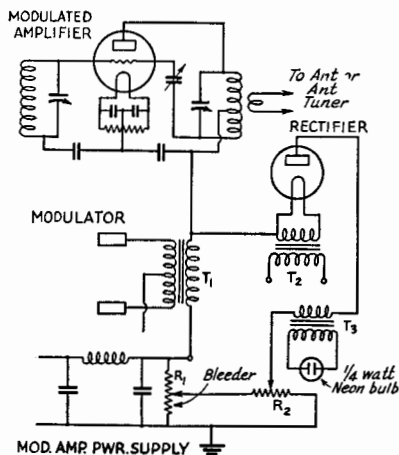

Fig. 1601 — A negative-peak modulation-per cent and overmodulation indicator.

The Radio Amateur's Handbook

75 and 100 per cent. However, on many 'phone transmitters, the plate voltage used for the modulated amplifier limits this range, since the voltage across R_2 , if the tap on R_1 is set at one-fourth the voltage in a transmitter with 2000-volt supply, may be as high as 500 volts. Unless a well-insulated potentiometer with front-panel knob (or a slider-type resistor mounted on the back of the control panel) is used, care must be taken to limit the voltage across R_2 to a value safe for the operator.

A suitable rectifier for use in this indicator is an '81 tube, with filament supplied by a 7.5-volt transformer having insulation to stand more than double the plate supply voltage. Although the inverse peak voltage on the rectifier tube will be higher than rated value, the current through the tube is so limited as to prevent rectifier overload trouble. An excellent 2.5-volt rectifier which may alternatively be used is the 2X2/879.

Modulated Amplifier Plate Current

If the transmitter is operating properly with sine-wave modulation up to 100 per cent, the d.c. plate current of the modulated amplifier should remain absolutely constant. The antenna ammeter should show increases up to 5 per cent with 100-per cent speech modulation, or increases up to 20 per cent with continuous sinusoidal input.

Movement of the r.f. amplifier plate current meter needle downward with plate modulation may indicate one or more of the following:

1. Insufficient excitation to the modulated r.f. amplifier — this is probably the most common cause of "downward modulation."
2. Insufficient grid bias on the modulated stage.
3. Wrong load resistance for Class-C r.f. amplifier.
4. Insufficient output capacity in filter of modulated amplifier plate supply (at least a 2-microfarad condenser should be used at this point).
5. Heavy overloading of Class-C r.f. amplifier tube or tubes (or insufficient filament voltage).

Movement of the modulated amplifier plate current needle upward may indicate one or more of the following:

1. Overmodulation (excessive audio power, audio gain too great).
2. Incomplete neutralization of the modulated amplifier.
3. Parasitic oscillation in the modulated amplifier.

When a common plate supply is used for both Class-B (or Class AB) modulator and

modulated r.f. amplifier, the plate current of the latter may "kick" downward with modulation even though the operating conditions are correct. This is traceable to comparatively-high power-supply voltage regulation; the varying additional load of the modulator stage may cause a drop in amplifier plate voltage, and similarly in amplifier plate current, of as much as 15 per cent with a power supply of very poor regulation, while the voltage and current variation of the modulated amplifier should not exceed 5 per cent if a high-quality power supply is used (one with regulation of the order of 10 to 15 per cent, no-load to full-load). Even more downward variation of the modulated amplifier usually accompanies modulation when a Class-B or Class-AB modulator and the r.f. buffer stage are operated from the same power supply.

Downward movement of the modulated amplifier plate current meter with modulation may be caused in high-power transmitters by poor regulation of the a.c. supply mains, even when a separate power supply unit is used for the modulator. This cause of plate-current variation may be detected by a similar kick of the filament voltmeters or of an a.c. voltmeter connected across the a.c. supply wires.

Use of Cathode-Ray Oscilloscope

The cathode-ray oscilloscope — even a small, inexpensive one — is invaluable to the 'phone amateur for determining modulation percentages with speech or constant sine-wave input, for observing the degree of linearity obtained with modulation of an r.f. amplifier, and for finding what audio-power output is available from a modulator without overdriving to distortion. A unit offering valuable test means at low cost is shown in Chapter 17.

While the oscilloscope may, in giving a single pattern, tell numerous facts about the operation of a transmitter, and point (for the experienced operator) directly to any source of trouble, the instrument may, unless applied to the transmitter with certain precautions carefully taken, give a pattern of grotesque proportions for which the transmitter is really not to be blamed. It sometimes happens that quite unusual patterns appear on the screen, and therefore the amateur must learn not only to analyze the modulation characteristics represented by correctly obtained patterns, but also to recognize the clues which show whether the cause of an unusual figure lies within the transmitter itself, or whether it is the result of improper application or adjustment of the oscilloscope.

Trapezoid vs. Wave Envelope

In general, patterns of two types — wave-envelope and trapezoidal — are used for

Adjustment of 'Phone Transmitters

checking the performance of 'phone transmitters. Each of the two patterns tells much about the characteristics of the modulated output of the transmitter, and the two together give an even more complete report of the operation. One large difference in the two patterns is the fact that the wave envelope picture is changed by a change of the speech amplifier input wave, while the trapezoidal

figure remains essentially constant if the modulation percentage is constant. Thus, if an audio-frequency oscillator with constant sine-wave output is used to feed a signal into the audio system of the transmitter, the output pattern, with proper operation of the transmitter and best adjustment of the oscilloscope, should resemble one of the two patterns of Fig. 1603-D. A change in either frequency or waveform of the audio oscillator output makes a change in the wave-envelope pattern (shown at left in Fig. 1603-D), while the trapezoidal pattern (at right in Fig. 1603-D) is practically unaffected by the change. With the modulation level remaining at 100 per cent, a change in sine-wave frequency makes no change at all and a change in wave shape causes only a slight change within the light area of the triangular figure. Because of this difference in the two patterns, the wave-envelope figure gives at once a picture of the over-all performance of the audio amplifier stages, the modulator, and the modulated amplifier, since any distortion contributed by an audio amplifier stage changes the wave shape of the modulating signal, and thus of the envelope of the oscilloscope pattern. If the envelope obtained with a sine-wave input is not sinusoidal, it may be because of distortion in the audio amplifier or non-linearity of the distortions. The trapezoidal figure, on the other hand, is used to indicate only the modulation percentage and linearity of the modulated r.f. amplifier.

Oscilloscope patterns which show the conditions of zero r.f. output, and a carrier with zero, 50-per cent, 100-per cent, and 125-per cent modulation, respectively, for each of the two systems are given in Fig. 1. Before application of the carrier, the oscilloscope connected for a wave-envelope pattern has horizontal sweep voltage applied, making a line across the middle of the tube. When the carrier is on, r.f. voltage applied to the vertical plates sweeps the spot up and down the screen as it moves across, so that a rectangular light area is formed. The height of this light area should be approximately $\frac{1}{3}$ of the screen diameter. Now, with a sine-wave input of 1000 cycles and sweep frequency of 500 cycles, patterns similar to the sketches at left of Fig. 1603-C and 1603-D should be obtained with 50- and 100-per cent modulation. With a change of the audio-frequency signal to 2000 cycles, or with a change of the sweep frequency to 250 cycles, four narrower cycles should replace the two broad ones shown in the sketch. For most critical examination, however, the proportions shown here usually prove best.

With the settings mentioned in the above paragraph — 500-cycle horizontal sweep and 1000-cycle signal — a.c. hum of 60 cycles will

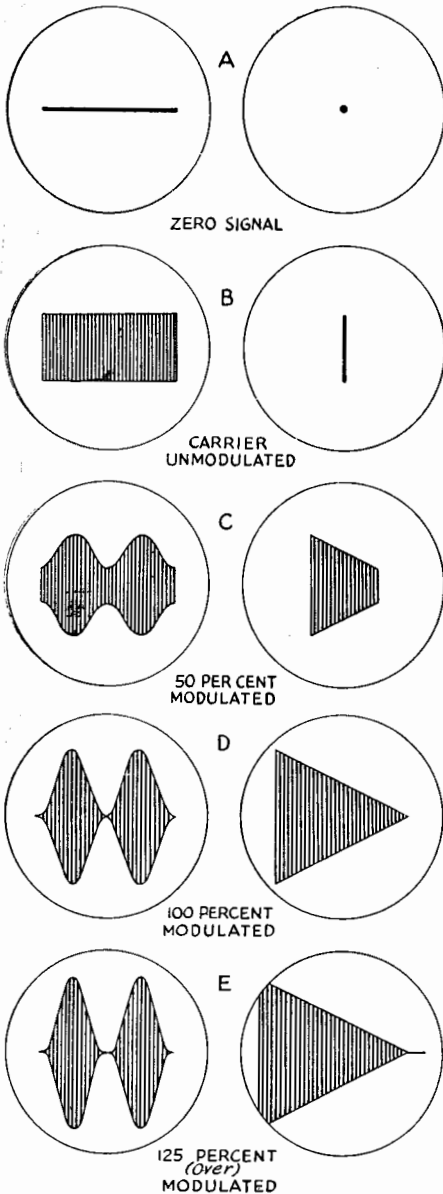

Fig. 1603 — Wave-envelope (left) and trapezoidal (right) oscilloscope patterns.

The Radio Amateur's Handbook

not be shown noticeably in the oscilloscope pattern, and 120-cycle power supply ripple will hardly be detected. Thus, a wave-form closely approaching that at the left in Fig. 1603-D may be obtained from a carrier having quite noticeable 60-cycle modulation in addition to the higher-frequency audio signal modulation. If the operator whistles before the microphone to provide a brief and fairly sinusoidal input signal, and sets the horizontal sweep frequency to make only two or three cycles in the pattern, he may be overlooking low-frequency hum modulation. Thus, to make a more complete test of the transmitter performance, he should set the horizontal sweep oscillator of the 'scope to give it a sweep frequency of 20 or 30 cycles and observe the pattern resulting with the gain control at normal setting and no signal applied to the input of the speech amplifier. If the oscilloscope pattern is then that of the sketch at left in Fig. 1603-B, the hum level of the transmitted signal is likely to be satisfactorily low. If the number of cycles (the number of full humps at the top of the pattern) is three, for 20-cycle sweep, or two for 30-cycle sweep, the hum present is 60-cycle hum and may be found to result from an ungrounded chassis, a poorly located tap on filament resistor, a bad tube, or induction from power lines. If the number of cycles is six for 20-cycle or four for 30-cycle sweep, the hum is probably the result of insufficient power-supply filter in one of the plate or grid power supplies for a.f. or r.f. stages.

Since the trapezoidal pattern depends on audio voltage output of the modulator stage for horizontal sweep, as well as on r.f. output voltage for vertical deflection, the beam of the cathode-ray tube is stationary when the transmitter plate switches are open, and an intense spot on the center of the screen results. The sketch at the right of Fig. 1603-A represents this condition. When the r.f. portion of the transmitter is running, unmodulated, the vertical line of Fig. 1603-B (right) is formed. As in the case of the wave-envelope pattern, the height of the unmodulated figure should be approximately $\frac{1}{8}$ the screen diameter. With 100-per cent modulation the width of the pattern should become roughly $\frac{3}{8}$ screen diameter, and the shape should become a true triangle, as sketched in Fig. 1603-D. With 50-per cent modulation, the width should be half of the 100-per cent modulation width, and the shape should be the trapezoid of Fig. 1603-C.

In contrast to the wave-envelope pattern, the trapezoidal figure shows immediately whether there is appreciable hum or noise modulation of the carrier before a signal is applied to the speech amplifier input. Further-

more, since the figure retains one general shape, speech input to the audio system results in a clear and meaningful pattern. Herein lies the most important advantage of the trapezoidal figure, for it gives a constant and easily interpreted indication of the modulation percentage. As the operator talks, the figure should expand and contract horizontally, reaching a point on the highest peaks of modulation. During the greater part of the time with speech, the wave-envelope pattern is an almost meaningless jumble, with occasional brief moments of appearance as the form for sine modulation. Bright, sharp dashes occurring in a horizontal line across the middle of the screen usually indicate modulation at or above 100 per cent, depending on their length. Experience indicates that usually when these bright dashes become noticeable, the carrier is already heavily overmodulated. Some relief of this jumbled pattern of the wave-envelope system on speech may be provided by use of either very low-frequency sweep (with only a small portion of the sweep voltage cycle carrying the spot completely across the screen), or a strong synchronizing voltage applied to the oscilloscope to control partially the frequency of the horizontal sweep oscillator. Nevertheless, purely from the standpoint of a convenient constant speech indicator, the trapezoidal figure is much to be preferred to the wave-envelope pattern.

Methods of Connection

The oscilloscope connections for the wave-envelope are usually simpler than those for the trapezoidal figure, if the oscilloscope is already provided with a sweep oscillator or an a.c. transformer winding and sweep control. The vertical deflection plates are coupled to the amplifier tank coil or an antenna coil by means of a 1-, 2-, or 3-turn pickup coil connected to the oscilloscope through a twisted-pair line, and the position of the pickup coil is varied until the proper height of the vertical deflection is obtained with the transmitter in normal operating condition, unmodulated. This completes the installation for an oscilloscope provided with 60-cycle transformer horizontal sweep supply. This connection is independent of the application of the modulating voltages — it applies for plate, grid, screen, plate-and-screen, or suppressor-modulation of the final amplifier. If a Class-B linear r.f. amplifier is used following the modulated stage, provision for r.f. pickup from both the modulated stage output and the output of the final amplifier should be made — the pattern from the output of the final r.f. amplifier must be regarded as the criterion of operation of the transmitter, since the modulation percentage of this stage is not necessarily that of the modulated stage.

Adjustment of 'Phone Transmitters

If the oscilloscope is provided with a sweep oscillator and a terminal for synchronizing voltage, a connection should be made between the synchronizing terminal and a grid of one of the first audio power amplifier tubes in the speech amplifier system. To insure against upsetting a d.c. circuit, a 0.01- μ f. tubular paper condenser should be connected in series with this lead. Since both the transmitter and the oscilloscope should be grounded, the return path for the synchronizing circuit is automatically completed.

If a trapezoidal pattern is desired rather than the wave-envelope, the r.f. input must be connected and adjusted just as outlined in the above paragraphs. In addition, a voltage divider must be connected across the voltage being used to modulate the final amplifier—that is, between ground and the modulation connection of the r.f. amplifier; and a small fraction of the modulator audio output voltage must be obtained from a tap on this divider.

In Fig. 1604-B and 1604-C connections are given for obtaining trapezoidal patterns from grid- and plate-modulated r.f. amplifiers, respectively. These two circuit diagrams merely

illustrate the connection of the horizontal sweep voltage divider between the modulated terminal of the r.f. stage and ground. For oscilloscopes equipped with internal amplifiers for the horizontal sweep, it is desirable to get a voltage divider arranged to supply only about 5 audio volts between ground and the tap, and to feed this low voltage to the input of the horizontal amplifier. This simply makes possible use of the gain control on the horizontal deflection amplifier for adjusting the width of the trapezoidal pattern. If such an amplifier is not available in the oscilloscope, the voltage divider should be made conveniently variable so the pattern width may be made satisfactory. For grid, suppressor, or screen modulation, resistor R_1 of Fig. 1604-B (the resistor between the modulated post and the tap for the horizontal sweep voltage) should be a 0.5-megohm, 1-watt carbon resistor. For amplification of the horizontal sweep voltage, resistor R_2 should be approximately 50,000 ohms for low- and medium-power transmitters, and approximately 10,000 ohms for high-power transmitters. Not more than two trials should be required to determine a value of R_2 suited for the oscillo-

scope used. For audio voltage to apply directly to the horizontal deflection plates, R_2 should be a potentiometer between R_1 and ground, with the connection from the oscilloscope through C_1 attached to the moving tap of R_2 . For high power transmitters, the resistance of this potentiometer should be roughly 0.2 megohm, for medium-power transmitters it should be 0.5 megohm, and for low-power transmitters it should be 0.5 megohm with resistor R_1 shorted from the circuit (R_2 connected between ground and the modulated terminal), with the oscilloscope voltage taken from the tap of the potentiometer, through C_1 . The potentiometer referred to above for all three of the cases may be a carbon-element volume control resistor.

The voltage divider for horizontal sweep voltage from a plate-modulated amplifier presents a slightly different problem from those just mentioned, since the importance of safety here should be given full regard. To begin with, resistor R_4 of Fig. 1604-C should be a 0.5-megohm, 1-watt carbon resistor for low-power transmitters; and

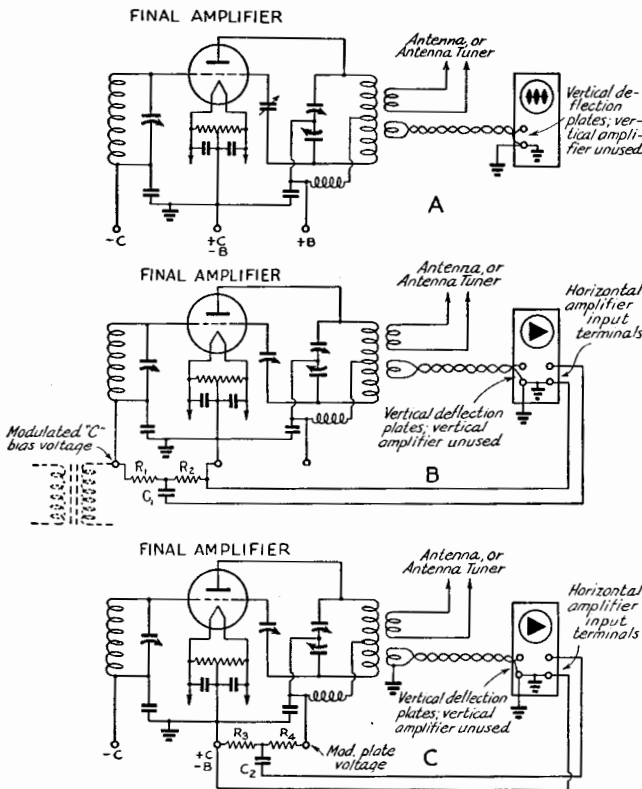

Fig. 1604—Oscilloscope connections for wave-envelope (A) and Trapezoidal (B and C) modulation patterns.

The Radio Amateur's Handbook

for medium- and high-power modulated amplifiers, should consist of a group of series-connected 0.5-megohm, 1-watt carbon resistors — one resistor for every 500 volts of the d.c. potential applied to the modulated amplifier. Thus, an amplifier operating with 1500-volt d.c. plate supply would require three series resistors, each having the specifications given above, connected in series. In any case, R_4 should be located within the modulator unit, so that the voltage carried to the oscilloscope will be isolated from the plate terminal of the modulated amplifier by this high resistance. For amplified horizontal sweep, the values of R_3 , all applying to 1-watt carbon resistors, should be roughly 25,000 ohms, 10,000 ohms, and 3000 ohms for low-, medium-, and high-power modulated amplifiers, respectively. For directly supplying the deflection voltage to the horizontal plates, resistor R_3 should be a carbon-element volume control potentiometer having a 0.5-megohm, 0.1-megohm, or 50,000-ohm resistance value, for low-, medium-, or high-power transmitters, respectively. The connection of C_2 should be removed from the junction of R_3 and R_4 when R_3 is a variable resistor, and then should be replaced on the variable tap of R_3 .

Troubles in Obtaining Patterns

Although many common faults in oscilloscope use are avoided by careful attention to the proper connections for use in obtaining a desired type of pattern, the figure appearing on the screen of the cathode-ray tube may be confusing to the operator because of its unusual shape.

When the wave-envelope pattern is used, compression of each cycle into too narrow proportions (with four or six audio cycles visible on the screen when the height of the unmodulated r.f. signal is $\frac{1}{2}$ screen diameter as recommended above) causes the outlines of the pattern to become noticeably non-sinusoidal though the modulation of the r.f. carrier is in reality perfectly sinusoidal. In order to understand this fact, it must be remembered that the apparent diameter of the spot on the screen is appreciable compared to the length of a cycle horizontally across the screen. This meaning is better explained by the sketch of Fig. 1605. One audio modulating cycle is shown in this sketch, and the envelope is first drawn as it would be if the spot on the screen were only a fine point of light. Then, allowance for a noticeable spot diameter is made for the positions at which the spot travel stops and reverses, and the outline of these spots is drawn on the figure, increasing the area of the modulation pattern, and more important, making the crests of the wave broader and the troughs narrower. It will be seen from the

above that the cycles of the wave envelope should be spread out so that if the height of the modulated pattern nearly fills the screen, not more than two or three audio cycles occupy the length of the screen area.

A point given much emphasis in most references on oscilloscope modulation checking — and justifiably so — is the importance of obtaining sweep voltage for a trapezoidal pattern

Fig. 1605 — Effect of spot area on outline of wave-envelope pattern.

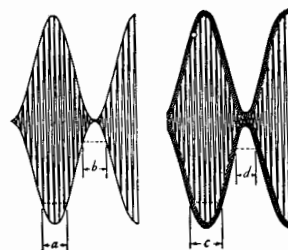

from the output of the modulator rather than from a preceding stage of the audio system. Fig. 1606 is a photograph of the pattern which resulted when the sweep voltage for a trapezoidal pattern was obtained from the output of the audio driver stage instead of the output of the modulator.

Figs. 1607 and 1608 are photographs of a wave-envelope pattern and corresponding trapezoidal pattern which might bring to the

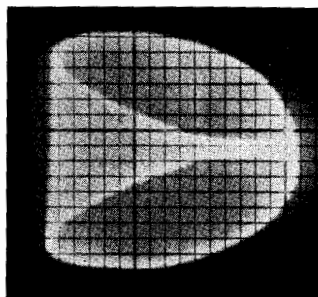

Fig. 1606 — Pattern showing effect of phase shift which results when sweep voltage for trapezoid is obtained from intermediate speech amplifier.

operator's mind doubts about the operation of the audio system and the modulated amplifier. Actually, though, the leaning of these patterns is produced by coupling between the horizontal sweep circuit and vertical deflection circuit of the oscilloscope. An r.f. voltage thus results across the horizontal plates, and this voltage acts to carry the spot a short distance across the screen at the same time that the higher r.f. voltage moves it vertically. The result is a diagonal travel of the spot with the r.f. signal, rather than vertical travel. This trouble is most common with carrier frequencies of the 14-, 28- and 56-Mc. bands. Experiment with

Adjustment of 'Phone Transmitters

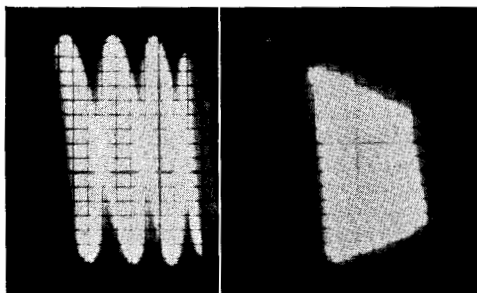

Fig. 1607 and Fig. 1608 — Wave-envelope and trapezoidal patterns which lean because of r.f. coupling between vertical and horizontal deflection circuits.

some of the more popular factory-built 'scopes indicates that a satisfactory cure for this trouble results from insertion of an r.f. choke (one of the popular pigtail connection pie-wound receiving chokes rated at 2.5-mh. inductance, 125 ma.) in series with the ungrounded horizontal deflection plate at the base of the cathode-ray tube. Some manufactured models have external deflection plate terminals located near the socket for the cathode-ray tube; apparently these work satisfactorily when provided with an r.f. choke external of the 'scope case, mounted by the pig-tail connections to the terminals.

Another source of confusing patterns is r.f. vertical deflection shown on the screen of the tube when the plate voltage is removed from the final r.f. amplifier. This may result from lack of neutralization of the final r.f. amplifier; in this respect, the oscilloscope may be used as a convenient and fairly sensitive neutralization indicator. If the final amplifier is properly neutralized, the vertical deflection may indicate r.f. pickup by the line connecting the pickup coil to the vertical plates of the oscilloscope. To minimize this undesired pickup, some type of compact twisted-pair or parallel-pair line should be used for bringing the r.f. signal voltage to the 'scope. A third cause of the zero-plate-voltage r.f. signal on the oscilloscope is often troublesome on the 10- and 5-meter bands, where it is difficult to use the oscilloscope at an operating position removed from the transmitter and keep the ground circuits of the two at the same potential. This difficulty simply requires experimentation to remove the r.f. signal from the 'scope when the plate voltage is off the final amplifier. Figs. 1609 and 1610 show the wave-envelope and trapezoidal pattern of an unneutralized modulated r.f. amplifier — very similar results are obtained when r.f. voltage is found across the vertical plates of the oscilloscope for reasons other than improper neutralization adjustment.

With the above difficulties removed from the oscilloscope picture of the transmitter modula-

tion, the patterns of Figs. 1611 and 1612 are obtained. While these pictures do not show ideal patterns, they do give a picture of the actual transmitter operation. From pictures such as these, an intelligent start may be made toward obtaining the best possible performance of the equipment at hand.

● GRID-MODULATED TRANSMITTERS

For best results with grid-bias modulation, a few simple requirements must be observed. Grid bias should be obtained only from B batteries, or a bias supply equipped with a low-resistance bleeder and provided with a high-capacity (4- to 8- μ fd.) condenser across the portion of the bleeder included in the grid circuit of the amplifier.

Some means of conveniently varying the bias voltage, continuously or in steps, should preferably be provided. It is desirable that the plate voltage be the maximum rated voltage for the tube. The r.f. driving power which gives best operation with grid modulation at the maximum rated plate voltage of the tube is usually one-fourth to one-half that required for normal telegraphy (Class C, unmodulated) operation. The r.f. grid circuit of the modulated amplifier should be loaded with a dissipative load, for which purpose either a non-inductive resistor may be connected across the grid tank circuit of the modulated amplifier (across the plate tank circuit of the preceding stage if capacity coupling is used), or a lamp bulb may be connected to a one- to three-turn loop and coupled to the grid coil of the amplifier (to driver plate coil with capacity coupling). Some means should be provided for conveniently varying the amount of r.f. excitation given to the grid of the modulated amplifier, for this is an important step in the process of adjustment of the system for proper modulation.

The first move in the tuning-up process is application of the maximum plate supply voltage available (within the rating of the tube for Class C telegraph operation), and loading and exciting the amplifier to the maximum obtainable r.f. output with the grid-bias voltage set for cutoff value at the plate voltage used.

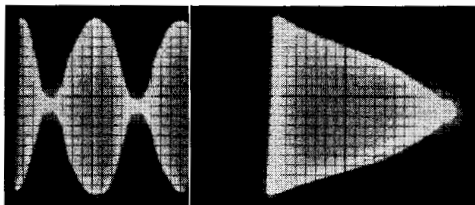

Fig. 1609 and 1610 — Wave-envelope and trapezoidal patterns obtained from modulated r.f. amplifier which was not properly neutralized.

The Radio Amateur's Handbook

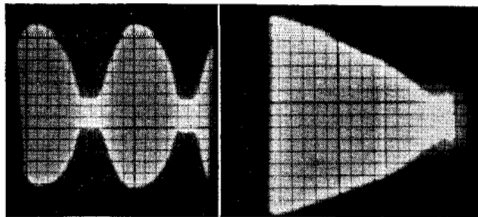

Fig. 1611 and 1612 — Patterns obtained from modulated r.f. amplifier with properly coupled oscilloscope — these patterns actually show the nature of the modulated r.f. output of the transmitter.

If this process is to be applied to a pair of 809 tubes in a push-pull or parallel r.f. amplifier, for instance, the full Class-C telegraph plate-voltage rating, 750 volts, should be applied to the plates. The grid bias voltage should be set at or near the value which produces plate-current cutoff at 750 volts plate supply; this bias value is found by division of the plate supply voltage by the amplification factor, 50, of the triode tubes ($\frac{750}{50} = 15$ volts grid bias for cutoff). The plate current of the tubes may be cut off by gradual increase of bias voltage from a bias power pack until the plate current falls to zero (with no excitation applied), or if 45-volt battery units are used for bias supply, the tap nearest - 15 volts, - $22\frac{1}{2}$, should be used.

With these plate and bias voltage settings, and with normal r.f. excitation applied to the grids, loading of the tubes *by means of a dummy load* should be applied and increased in small steps until further loading results in no further increase of r.f. output, and the plate current of the r.f. amplifier should be noted at this point. While making this first adjustment, care should be used to operate the key only for short dashes rather than to leave the transmitter running for an appreciable length of time, since this type of operation would greatly overload the tube or tubes of the modulated amplifier.

Half the total plate dissipation rating of the tube or tubes used in the r.f. amplifier to be modulated should then be divided by the value of plate voltage available when the power supply is lightly loaded, and the value obtained should be multiplied by three for finding the current (in amperes) at which the stage should operate with grid modulation. Thus, if the above-mentioned pair of 809 tubes is used in a grid-modulated r.f. amplifier, and the full rated voltage of 750 is available from the plate supply when lightly loaded (with current drain of 75 to 150 ma.), then the total dissipation of the tubes, 50 watts (25 watts rated dissipation per tube), divided by 750 (plate voltage) yields approximately 0.067 ampere, or 67 ma. Three-halves this value is

0.100 ampere, approx., or 100 ma. This is the proper operating current for a pair of 809 tubes grid-modulated at 750 volts.

Now, if the plate current which accompanied greatest obtainable output is greater than double the above figure — that is, greater than 200 ma. for a pair of 809 tubes — the excitation to the modulated r.f. amplifier should be reduced, and the process of finding the d.c. plate current at greatest obtainable output should be repeated. In this way, the excitation is adjusted to give maximum output of the transmitter at double the operating plate current (with cut-off bias still applied to the r.f. amplifier). It is highly desirable that the tuned grid circuit of the r.f. amplifier, or the tuned plate circuit of a preceding capacity-coupled stage, be heavily loaded by a simple dissipative load. The most convenient way of meeting this requirement is to provide a 110-volt lamp bulb connected to one or more turns of wire, coupled to the above-mentioned tuned circuit. This method may also provide excitation control of the modulated amplifier, since this excitation may readily be decreased by increase of the lamploading, and the stability of the r.f. excitation is simultaneously increased.

The final adjustment for modulation is increase of the grid bias voltage on the r.f. amplifier, from the cutoff bias value at which adjustments are made, to the bias voltage at which plate current (with transmitter running) is reduced to the operating value as obtained above. For the pair of 809 tubes used as an example, this final adjustment would be increase of the bias voltage from approximately 15 volts (or $22\frac{1}{2}$ if 45-volt batteries are used for bias) to some voltage at which the plate current is reduced from 200 ma. to 100 ma., the operating current for the stage. This proper operating bias value for grid-modulated 809's usually is in the range between 65 and 135 volts (all bias voltages mentioned in this paragraph are values of negative grid bias).

High-Power Grid-Modulated 'Phone

The adjustment procedure outlined above, and applied for illustration to a low-power transmitter with two type 809 tubes in the r.f. output stage, applies quite as well to high-power grid-modulated transmitters.

For example the plate voltage for 250TH tubes need not exceed 2000 volts d.c. for plate-modulated 'phone operation up to 1 kw. input, or 2000 to 2500 volts for efficient c.w. telegraph operation, but the plate supply voltage for grid modulation should be near the maximum rated plate voltage for the tubes used — in the case of 250TH's, 2500 to 3000 volts — for obtaining greatest grid-modulated output. The lower value, 2500 volts, frequently used

Adjustment of 'Phone Transmitters

with this type of high-power tube, is therefore quite satisfactory for high-power grid-modulation of the 250TH's.

First step in adjustment, using 250TH tubes as an example is provision of cutoff grid bias voltage. The plate voltage, 2500, divided by the amplification factor, 32, sets the needed bias voltage at approximately 78 volts (any

is therefore the proper operating current for the grid-modulated pair of 250TH's with 2500 volts plate supply.

If the output of the transmitter in the above adjustment process reached a maximum value at 600 ma. (double the proper operating current), the excitation applied is approximately correct for grid modulation of the amplifier. This should be the stabilized value of the grid excitation — in other words, a lamp-and-loop or other stabilizing dissipative load should be coupled to the grid tank circuit of the final r.f. amplifier during the test to determine the correct amount of r.f. excitation. If the maximum output is reached at a loading accompanied by much greater plate current than 600 ma., the excitation to the r.f. amplifier should be reduced, either by increase of the power dissipated in the excitation-stabilizing lamp or by decrease of the buffer loading.

With correct excitation applied to the final r.f. amplifier, the grid bias is then increased until the plate current reaches the operating value, 300 ma. Since the operating bias of the r.f. amplifier may be as high as 400 volts, rectifier-filter power supply should be used rather than battery bias.

Oscilloscope patterns representing different conditions in the grid-modulated amplifier are shown in Fig. 1613. The cathode-ray oscilloscope, a very useful instrument for use with a plate-modulated transmitter, is an even more useful and desirable instrument for adjustment and operation of a grid-modulated 'phone.

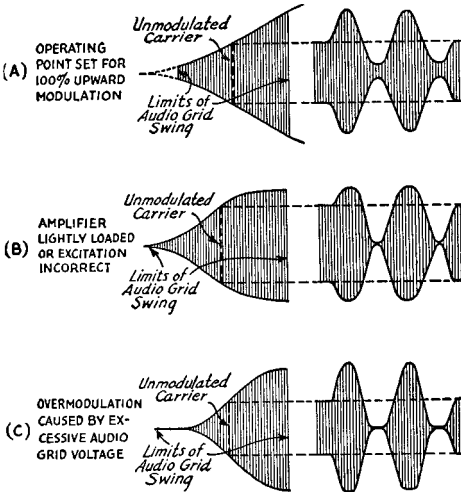

Fig. 1613 — Oscilloscope patterns representing proper and improper grid-bias or suppressor-grid modulation. The pattern obtained with a correctly adjusted grid-bias modulated amplifier is shown at A. The other two drawings indicate non-linear modulation, accompanied by distortion and a broad signal.

value between 67 and 90 should therefore be satisfactory).

With the tubes biased to no-excitation plate-current cutoff, light excitation is applied and the amplifier stage is more and more heavily loaded until increase of loading fails to result in increased output. Loading of the amplifier during these adjustments should be by means of a dummy load rather than an antenna. The output of the transmitter into the dummy load may reach or slightly exceed one kilowatt of r.f. power, and accordingly the load linked to the r.f. amplifier may be composed of two parallel- or series-connected 500-watt lamps. Again it must be warned that the tubes will be overheated by this type of operation if prolonged. The operator is therefore compelled to use caution in finding the plate current at which maximum output is reached, not to operate the transmitter longer than brief dashes — just long enough to make meter readings.

The rated plate dissipation of a 250TH tube is 250 watts — of a pair, 500. Division of the total dissipation of the two tubes by the operating plate voltage, 2500, gives 0.2 ampere. Three-halves this value, 0.3 ampere or 300 ma.,

Correct Grid Modulation

With no audio signal applied, the efficiency of the grid-modulated amplifier, properly adjusted, is approximately 30 per cent. On positive modulation peaks, the efficiency becomes approximately 60 per cent and the instantaneous value of peak plate supply current is approximately double the no-signal value. Hence, with the plate supply voltage remaining constant through an audio cycle, the peak power output of the modulated amplifier is approximately four times the normal carrier, as required for proper modulation. On the opposite (negative) peak of the audio cycle, the instantaneous value of plate current becomes zero (provided proper adjustment with stable excitation is used) and the output falls to zero. The average efficiency of the grid-modulated amplifier is lowest with no modulation, and rises noticeably with 100-per cent modulation. The limit of the power input to 3/2 times the total plate dissipation of the stage is based on the no-modulation efficiency.

When tone modulation is applied, it should be possible to cause the antenna current to increase and the plate current to rise simultaneously. This is not the operating condi-

The Radio Amateur's Handbook

tion for speech modulation, however. With speech modulation the antenna current should show rise of not more than 5 per cent on peaks, while the plate current of the amplifier should do no more than flicker. Inability to obtain antenna current rise with test modulation shows that the positive peaks are being flattened off as shown in 1613-B. This figure shows oscillograph patterns for both audio-frequency a.c. sweep (left) and synchronized linear sweep (right). If the antenna current cannot be made to rise, either there is insufficient audio modulation available, or the modulation characteristic is flattening equally on positive and negative peaks, as shown in Fig. 1613-C. The latter should be corrected by adjustment of coupling to the antenna and variation of the r.f. excitation. *The amplifier should not be adjusted for maximum carrier efficiency.* In fact, for proper modulation the antenna loading will be somewhat greater than is ordinarily the case, the efficiency being necessarily reduced to obtain linear modulation.

The plate current should be practically steady at a fixed value either with or without modulation, although a slight upward kick (not more than 5 per cent) is permissible on modulation peaks. If there is a downward kick in plate current or a pronounced upward kick, one or more of the following may be the cause, in addition to improper neutralization and the possibility of parasitic oscillations:

Downward kick: Too much r.f. excitation; insufficient operating bias; distortion in modulator or speech amplifier; too-high resistance in bias supply; insufficient output capacity in plate-supply filter to modulated amplifier; amplifier plate circuit not loaded heavily enough; plate-circuit efficiency too high under carrier conditions.

Upward kick: Overmodulation (excessive audio voltage); distortion in audio system; regeneration because of incomplete neutralization; operating grid bias too high.

A downward kick in plate current will accompany an oscilloscope pattern like that of Fig. 1613-B; the pattern with an upward kick will look like Fig. 1613-A with the shaded portion extending farther to the right and above the carrier, for the "wedge" pattern.

The source of grid bias should have low internal resistance so that when the grid current varies with modulation there will not be an appreciable shift in the operating grid bias. A regulated bias supply of the type shown in Chapter 11 is recommended for grid-modulated amplifiers.

● ADJUSTMENT OF SUPPRESSOR-MODULATED AMPLIFIERS

The operating principles in suppressor-modulation of a pentode r.f. amplifier are identical

with those described for grid-bias modulation. Adjustments are somewhat simpler, however, because the bias on the suppressor grid can be adjusted independently of bias and excitation to the control grid. Except for suppressor bias, the tube should be operated under the same conditions as for c.w. telegraph service, although it is sometimes beneficial to supply somewhat more excitation when suppressor modulation is to be applied.

To set the operating conditions, adjust the amplifier for maximum output at rated maximum input, using the maximum positive recommended suppressor bias. Then apply negative bias to the suppressor, adjusting its value until the antenna current drops to half the figure obtained under maximum conditions. Simultaneously, the plate current also should drop to half its maximum value. The amplifier is then ready for modulation. Should the plate current not follow the antenna current in the same proportion when the suppressor bias is made negative, the loading and excitation should be readjusted to make them coincide.

The oscilloscope patterns of Fig. 1613 are typical of suppressor modulation.

● ADJUSTMENT OF CATHODE-MODULATED AMPLIFIERS

As explained in Chapter 6, cathode modulation is a combination of grid-bias and plate modulation. In most respects the adjustment procedure is similar to that for grid-bias modulation; that is, the critical adjustments are those of antenna loading, grid bias, and excitation. The proportion of grid-bias to plate modulation will determine the operating conditions; obviously no completely definite procedure can be given when these quantities are variable.

The operating conditions are best set with the aid of an oscilloscope. With proper antenna loading and excitation, the normal wedge-shaped pattern will be obtained at 100% modulation. As in the case of grid-bias modulation too-light antenna loading will cause flattening of the up-peaks of modulation (downward modulation), as will also too-high excitation. The antenna loading should be adjusted to the point where a further increase in loading causes a decrease in antenna current. The cathode current will be practically constant under 100% modulation when the proper operating conditions are reached.

The cathode circuit of the modulated stage must be independent of other stages in the transmitter; that is, when filament-type tubes are modulated they must be supplied from a separate filament transformer. The filament by-pass condensers should not be larger than about 0.002 μ fd., to avoid by-passing the audio.

Adjustment of 'Phone Transmitters

● 'PHONE BROADCAST INTERFERENCE

Ordinarily, broadcast interference by a 'phone station may be attributed to one or more of five causes, as listed below:

1. Overmodulation, or lack of neutralization of modulated amplifier. Such operation is illegal to begin with, even in absence of reported b.c. interference. It is readily detected by monitoring the transmissions, and by effects on the instruments in the station.

2. Direct image interference. This type of interference, nearly always accompanying medium- or high-power 160-meter 'phone operation, and capable of long distance reception, is one of the most common types. Small 4-, 5-, and 6-tube superheterodynes — particularly those without tuned r.f. amplifier preceding first detector — are nearly always susceptible to this type of interference, and some of the larger sets are similarly troubled because of inadequate shielding.

3. Reception by superheterodyne receivers because of mixing of signal input with second, third, and higher harmonics as well as the fundamental output of the receiver high-frequency oscillator. Like the trouble mentioned in the paragraph above, this type of interference lies within the function of the broadcast receiver, and correction properly should be made there. This type of interference occurs with 160- and 80-meter operation, and sometimes even with 20-meter signals.

4. Whereas the second and third listed types of interference often accompany operation in the two low-frequency amateur bands, a fourth interference cause — direct rectification of the transmitted signal in the receiver second detector (or the detector of a t.r.f. set) — most frequently results from 10- and 5-meter 'phone operation, with occasional cases of 20-, 80-, and 160-meter interference in addition. Broadcast receiver tuning usually has little effect on reception of the amateur station in this manner. Cure of this interference is almost entirely limited to additional shielding of exposed grid-caps, grid wires, coils, chassis bottoms, or other exposed points in the receiver.

5. A cause of broadcast interference which becomes less common as receiver design technique advances is known as "cross modulation." This interference results when the operating point of the input tube of a receiver is varied with the modulation of the strong r.f. field produced at the receiver by the amateur 'phone transmitter. This cause of interference is recognized at once when modulation of the amateur station appears each time a broadcast station is tuned in (there is usually no interference of this type between stations). For removal of this trouble from broadcast re-

ceivers, some type of filter — a wave-trap if the amateur transmitter interferes when operated on one frequency only; a small r.f. choke in series with the b.c. receiving antenna lead-in, if the latter does not result in too much decrease of b.c. reception; or a low-pass filter (as described in Chapter 15) in series with the antenna — is almost always the best cure.

Since interference of the types listed second and third above are quite common, largely due to the present predominance of very low quality, cheap, small broadcast receivers, a table showing the broadcast frequencies to which such a set with standard 455-kc. intermediate frequency may be tuned when interference of these types occurs is given below. If attempts to remove such interference by shielding the receivers affected are unsuccessful, it is sometimes helpful to choose a nearby frequency which does not produce interference of these types at frequencies of the vicinity's more popular broadcast stations.

In all cases of broadcast interference, it is the duty of the radio amateur to be as helpful as possible to the broadcast listener in at-

Broadcast Band Frequency to which BC Receiver Is Tuned	Superheterodyne Oscillator Freq. of BC Receiver (455-kc. I.F.)	BC Receiver Osc. Harmonic Resulting in Reception of Amateur 'phone	Image Freq. of Reception (if within amateur band)	Reception Frequency Due to BC Receiver Osc. Harmonics
890 kc.	1345 kc.		1800 kc.	
1090	1545		2000	
672.5	1127.5	2nd Harmonic		1800 kc.
772.5	1227.5	2455		2000
1267.5	1722.5	2nd Harmonic		3900
1317.5	1772.5	3545		4000
693	1148	3rd Harmonic		3900
727	1182	3546		4000
997	1452	3rd Harmonic		3900
1030	1485	4455		4000
1257	1712	8th Harmonic		14150
1269	1724	13696		14250
1371	1826	13792		14150
1383	1838	14608		14250
		14704		

tempting to eliminate or reduce the interference, even though the b.c. receiver be at fault, Some explanation of the cause of trouble, together with helpful suggestions and willingness to cooperate, often go far in maintaining peaceful relations with neighbors.

● MODULATION TROUBLES

Most of the common troubles in obtaining proper modulation have already been described. There are also a few which are not directly tied up with adjustment of the r.f. amplifier and modulator, but have to do with equipment operation. A common one — prob-

The Radio Amateur's Handbook

ably because plate modulation, usually by means of a Class-B modulator and often by a Class-AB modulator, is used by many more amateurs than are other forms of modulation — is an entirely unnecessary but nevertheless disastrous occurrence in high-power modulators. This trouble — destruction of a modulator output transformer, modulator tube, or wiring of the modulator output circuit — *is the result of applying speech input to the modulator system with no load on the modulator.*

Four precautions against this trouble make it a totally unwarranted loss of oftentimes expensive amateur transmitting gear. The first of these, obviously, is the exercise of caution to note that the modulated amplifier is working properly at normal d.c. plate current before the modulator is operated. The second is provision, in elaborate and expensive transmitters, of an underload relay whose contacts, in series with the primary circuit of the modulator plate supply, are held closed during 'phone operation by adequate operating current of the modulated amplifier, and thus, a normal modulator load. Third, a simple and inexpensive precaution is provision of a spark gap across the secondary output terminals of the modulation transformer. Such a gap may be made of two pieces of stiff wire attached rigidly to the output connections, with ends failing to meet by a gap of a small fraction of an inch, dependent on the modulator output voltage. The gap spacing is determined by a trial and error process. If the modulator output modulates an r.f. amplifier input power of one-half to one kilowatt, a gap of the order of $\frac{1}{4}$ inch should be used for the first test. If the heaviest modulation ordinarily used fails to break down this gap, it should be shortened until it just breaks with 100-per cent modulation. The spacing of the gap should then be approximately doubled. An eighth-inch or smaller gap may be used at the outset of the spacing test with medium and lower power transmitters. Spacing of the gap is of course varied by light bending of the wires forming it.

The fourth precaution is a very practical and simple rule to remember: Downward movement of the plate current meter of a Class B or Class AB modulator with application of speech usually indicates that the load has been removed from the transformer secondary. Less often, downward modulation of the modulator plate current indicates that the modulator d.c. grid circuit is open or high-resistance. Thus, if application of speech input to a modulation system causes the modulator plate current to decrease, seek the source of trouble before further attempting to modulate.

R.F. Feedback into Speech Amplifier

In the great majority of cases where high-

gain speech amplifier and modulator systems are coupled to medium- and high-power transmitters, feedback, and an audio "whistle" result when the gain control is advanced. This is usually due to detection by the first speech amplifier tube of r.f. voltage at the grid of this tube because of the strong transmitter field in which the speech amplifier is operated. Of several steps which may be taken to avoid or minimize this rectified r.f. feedback, a few of great importance are listed below:

1. Preferably, the input stage may be balanced (push-pull), as the two grids are about equally exposed to the r.f. field, and the detected r.f. signals from the two cancel.

2. Whether the input stage is single-tube or push-pull, the grid circuit should be thoroughly shielded. A box which completely encloses microphone jack, grid circuit resistors and condensers, and input tube is advantageous; though separate shields for mike jack, resistors and condensers, and tube or tubes may be used. The latter may consist simply of the grounded metal shell of such a tube as a 6J7 or 6SJ7. The latter of these types is greatly preferred for metal chassis construction since the grid connection may be kept within the shield formed by the chassis.

3. Placement of the speech amplifier — particularly of the first two stages — is very important. The worst conceivable position for this portion of the speech amplifier is in the immediate vicinity of a final r.f. amplifier plate tank coil. Also undesirable, especially when a transformer is used for microphone or first-to-second stage coupling, is location of the speech amplifier too near transmitter power supplies. Indeed, it is desirable to have the small power supply for the speech amplifier itself located as far from any microphone or other low-level audio-coupling transformer as conveniently possible. If very high gain is desired from the audio system, it will be found advantageous to build the speech amplifier stages into a metal cabinet and place this unit at a distance of several feet from the remaining transmitter units. A 500- or 200-ohm line may be used with appropriate transformers for coupling with this arrangement.

If hum or r.f.-audio feedback is found difficult to eliminate, points of importance may be found by operating the transmitter carrier first, monitoring it to be certain that the hum or noise doesn't originate with the r.f. stages and power supplies. When the operator has found that the r.f. system itself is well behaved, he may apply plate voltage to the modulator, the audio driver, and to the speech amplifier stages in turn from the driver to the first amplifier. In this way, stages responsible for undesired noise in the transmitter modulation readily may be found.

Measurements and Measuring Equipment

Instruments for Checking Frequency and Modulation — Monitors for Code and 'Phone Transmission — Audio and R.F. Signal Generators — Field-Strength Meters — D.C., A.C., and R.F. Voltmeters — Oscilloscopes

THE proper operation of all but the very simplest of transmitters and receivers calls for the use of a certain number of instruments of various types. While the amateur station can be operated successfully with nothing more than a means for checking transmitter plate input and frequency — and for proper modulation, in the case of a 'phone transmitter — the progressive amateur is interested in instruments and measurements as an aid to better performance. The measure of the perfection of an amateur station, once a satisfactory transmitter and receiver have been provided, is the extent and utility of the auxiliary measuring and checking apparatus provided.

● THE AMATEUR'S LABORATORY

The following is a list of instruments which every amateur might well include in his equipment:

- Absorption frequency meter.
- Heterodyne frequency meter and signal generator.
- 100-kc. standard.
- Field-strength meter.
- Audio oscillator.
- Cathode-ray oscilloscope.
- Multi-range voltmeter.
- Ohmmeter.
- Vacuum-tube voltmeter.

An assortment of milliammeters is desirable, as are neon bulbs and flashlight bulbs with pick-up coils, for transmitter adjustment. Ordinary light bulbs of various sizes with attached flexible leads should be at hand to make power output comparisons.

Representative instruments from the above list will be described in this chapter. Some can profitably be combined into multi-purpose instruments; the manner and extent to which this is done is left to the ingenuity of the individual amateur. It should be realized, however, that multi-purpose equipment is never as useful as its equivalent in separate instruments, and the latter are nearly always to be preferred.

● FREQUENCY MEASUREMENTS

Dependable frequency-measuring gear is desirable in the amateur station for several closely-related purposes:

- To insure that the transmitter is operated in the desired frequency band;
- To set the transmitter to a desired frequency (if a self-controlled oscillator is used);
- To determine the frequency of a received station, or to calibrate a receiver;
- To determine the harmonic at which a frequency multiplier stage operates;
- To determine whether the harmonic output of a transmitter is objectionably strong.

Section 12.135 of the F.C.C. Regulations states: "The licensee of an amateur station shall provide for measurement of the transmit-

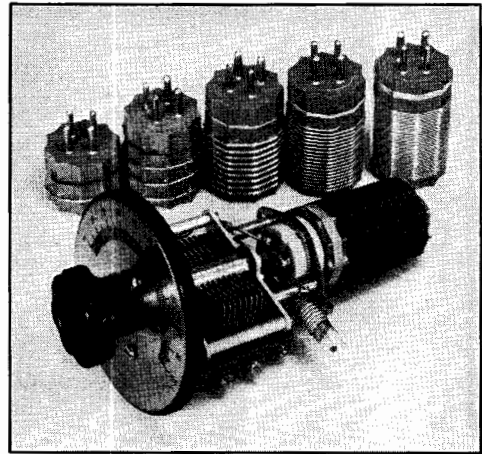

Fig. 1701 — Simple absorption frequency meter. A coil socket — a condenser — a dial plate mounted on an insulating disc which also serves as a handle — a flashlight bulb on a bracket — and a set of coils. Indispensable for identifying harmonics, locating parasitics, checking oscillators.

Coil forms are cut down close to the winding to facilitate tight coupling when necessary.

The Radio Amateur's Handbook

ter frequency and establish procedure for checking it regularly. The measurement of the transmitter frequency shall be made by means independent of the frequency control of the transmitter and shall be of sufficient accuracy to assure operation within the frequency band used."

In the absence of more elaborate frequency-measuring equipment, the receiver (with antenna disconnected) may be used to give at least some idea of transmitter frequency. To do this it is necessary to calibrate the receiver dial settings in terms of frequency if it is not already so calibrated. Some idea of band limits can be obtained by listening to other amateur stations, noting where amateur activity stops at each end of the band.

If operation near a band edge is contemplated, however, the above quoted amateur regulation requires a more precise frequency checking method. If the receiver is well made and has good inherent stability, a band-spread dial calibration may be relied on to within perhaps 0.2 or 0.3 per cent. Some manufactured models having factory calibration may be used to even closer limits.

The transmitter frequency can be checked by listening in the receiver to the oscillator alone, with r.f. power amplifier turned off, if the signal is too strong and blocks the receiver.

In one respect the transmitter frequency check provided by a calibrated receiver is in-

adequate. Usually, even the oscillator stage of a multi-stage transmitter will be heard with the receiver tuned not only to the fundamental output frequency, but to a harmonic as well. Often a sensitive superheterodyne receiver will receive three or four harmonics of a transmitter, all with noticeably high signal strength. In order to determine which is the fundamental output frequency of the transmitter, and on what harmonics the frequency multiplier stages are operated, an absorption frequency meter should be used.

● ABSORPTION FREQUENCY METERS

The simplest type of frequency meter consists of a coil and condenser, tunable over the frequency range desired. A frequency meter of this type, when tuned to the frequency of the transmitter and loosely coupled to the tank coil, will extract a small amount of energy from the tank. The energy thus extracted can be used to light a small flashlight lamp. Maximum current will flow in the lamp when the frequency meter is tuned exactly to the transmitter frequency, hence the brightness of the lamp indicates resonance. A more accurate indication may be obtained by substitution of a thermo-galvanometer for the lamp. Better yet, a vacuum-tube voltmeter can be used as the indicator. Although this type of frequency meter is not well adapted to precise measurement of frequency, it is useful in a variety of ways.

Figs. 1701-02 show a simple absorption frequency meter with a link-coupled flashlight bulb as resonance indicator. Commercial coils can be used for the lower frequency ranges, simplifying construction. Overlapping tuning ranges cover the entire scale from broadcast band to ultra-high frequencies.

Figs. 1703-04 show an absorption-type frequency meter equipped with a diode-rectifier vacuum-tube voltmeter as an indicator. The sensitivity of the indicator depends on the range of the meter. Any instrument from 0-200 microamperes up may be used, with 0-1 ma. a good range for average amateur work.

Calibration of the absorption frequency meter calls for a receiver of the regenerative type to which the coil in the meter can be coupled. With the detector oscillating weakly, the frequency meter should be brought near the detector coil and tuned over its range until a setting is found which causes the detector to stop oscillating. The coupling between meter and receiver should then be loosened until the stoppage of oscillations occurs at only one spot on the meter tuning dial. The meter is then tuned to the frequency at which the receiver is set. If the receiver is set on several stations of known frequency, a number of points for a calibration curve can be obtained for each frequency-meter coil.

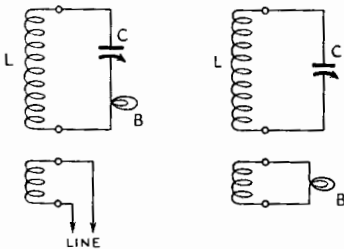

Fig. 1702 — Simple absorption frequency meter circuit at left is used chiefly in transmitter work, with link line to circuit being checked.

Circuit at right has bulb indicator loosely coupled to tuned circuit, giving sharper resonance point for frequency checking, etc.

B — 1.4-volt 50-ma. dial light.

C — 150- μ fd. variable (Cardwell MR-150-BS).

L — Coils covering high-frequency spectrum with overlapping ranges, wound on 1½-inch dia. forms.

Freq. Range	Wire Size	No. of Turns	Length of Winding	Link ¹
1.1-3.0 Mc.	No. 28 e.	81¾	1½"	17 t.
2.5-6.0 Mc.	No. 24 t.	37¾	1½"	11 t.
4.5-12 Mc.	No. 20 t.	17¾	1½"	6 t.
7.5-20 Mc.	No. 16 t.	8¾	1½"	4 t.

(The above coils are available in commercial form, completely wound: Hammarlund SWK-4.)

25-70 Mc. No. 16 t. 2¾ 1" 2 t.

40-100 Mc. No. 16 t. ¾ — ¾ t.

¹ Closewound, No. 30 d.s.c., ¼-inch from bottom end of primary winding.

Measurements and Measuring Equipment

Fig. 1703 — Absorption frequency meter with vacuum-tube voltmeter resonance indicator. Plug-in coils cover the range of approximately 170 kc. to 60 Mc. A dial reading to 1 part in 1000 affords over-all calibration precision of about 0.25 per cent.

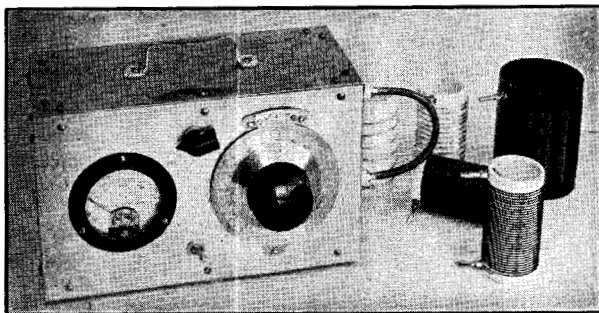

The absorption frequency meter is particularly useful for checking the tuning of a transmitter stage (to insure that the stage is not tuned to a harmonic instead of the desired frequency, for instance), for determining the frequency of parasitic oscillations in the transmitter, and for finding the frequency range covered by various oscillators.

For transmitter checking, a flashlight lamp or other indicator is not entirely necessary, since resonance will be indicated by a flicker in plate current of the stage being checked as the meter is tuned through resonance.

The absorption frequency meter can also be used for comparative measurements of transmitter harmonic output under various adjustments. The vacuum-tube voltmeter indicator is especially useful in this connection, since the meter readings will be approximately proportional to voltage, if distance is held constant.

Heterodyne Frequency Meter

For more accurate measurement of transmitter frequency, a heterodyne frequency

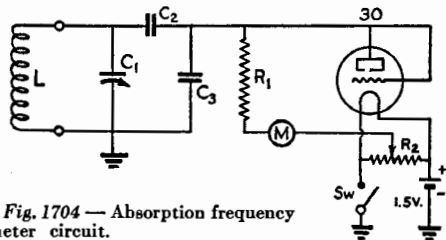

Fig. 1704 — Absorption frequency meter circuit.

C_1 — 500- μ fd. variable (National EMC-500).

C_2, C_3 — 50- μ fd. midget mica.

R_1 — 40,000-ohm, $\frac{1}{2}$ -watt.

R_2 — 100-ohm potentiometer (Centralal WW).

L — Plug-in inductances, wound (except L_1 and L_6) on $1\frac{3}{4}$ -inch National XR-13 forms. L_1 on 3-inch hakelite form. Winding length app. $2\frac{3}{4}$ inches.

Coils	Approx. Range	No. Turns	Wire Size
L_1	170-500 kc.	180	No. 28 e.
L_2	500-1500 kc.	100	No. 24 d.c.c.
L_3	1.5-4.5 Mc.	33	No. 14 tinned
L_4	3-9 Mc.	15	No. 14
L_5	8-25 Mc.	6	No. 14
L_6	20-60 Mc.	$\frac{1}{2}$	$\frac{1}{4}$ " c.t.

1.5-volt dry cell (Burgess 4FA).

meter should be provided. The heterodyne frequency meter is a small oscillator, completely shielded. It must be so designed and constructed that it can be accurately calibrated and will retain its calibration over long periods of time. The oscillator used in the frequency meter must be very stable; that is, the frequency of oscillation at a given dial setting must be practically the same under any conditions. Plug-in coils or switches are not ordinarily used in the frequency meter; instead, a solidly built and firmly mounted tuned circuit should be permanently installed, and the oscillator panel and chassis reinforced for rigidity. The oscillator ordinarily covers one band only, harmonics being used on the higher frequencies.

The frequency meter must possess a dial which can be read precisely to a fraction of a division. To obtain accuracy it is necessary to read the scale to at least one part in 500; ordinary dials such as are used for transmitters and inexpensive receivers are not capable of such precision, but laboratory-type dials which meet this requirement are available. Care should be taken to select one which has fine lines for division marks, and which has an indicator very close to the dial scale so that the readings will not appear different when the dial is viewed from different angles.

The Electron-Coupled Frequency Meter

One of the most stable oscillator circuits, and therefore most suitable for the frequency meter, is the electron-coupled circuit. The oscillation frequency is practically independent of moderate variations in supply voltages, provided the plate and screen voltages applied to the screen-grid tube used are properly proportioned. Furthermore, because of the nature of the circuit it is possible to take output from the plate with but negligible effect on the frequency of the oscillator. A third feature is that strong harmonics are generated in the plate circuit so that the meter is useful over an extremely wide range of frequencies.

A typical diagram for a simple form of electron-coupled frequency meter is given in Fig. 1705.

The Radio Amateur's Handbook

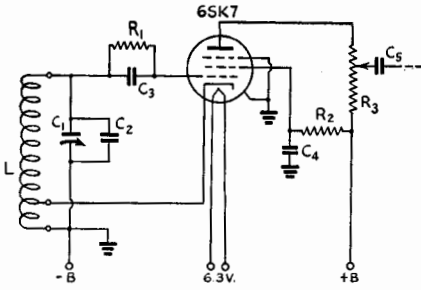

Fig. 1705 — General utility electron-coupled oscillator circuit. As Heterodyne Frequency Meter (1750-2050 kc.):

- C₁ — 100- μ fd. variable.
- C₂ — 200- μ fd. zero drift fixed mica.
- C₃ — 100- μ fd. midget mica.
- C₄ — 0.01- μ fd. 400-volt paper.
- C₅ — 0.002- μ fd. midget mica.
- R₁ — 50,000-ohms, $\frac{1}{2}$ -watt.
- R₂ — 75,000-ohms, $\frac{1}{2}$ -watt.
- R₃ — 20,000-ohm potentiometer. (May be replaced by 2.5-mh. r.f. choke.)
- L — 33 turns No. 22 on $1\frac{1}{2}$ -inch form, winding length $1\frac{1}{2}$ inch. Cathode tap 8 turns above ground end.

As 100-kc. Calibrating Oscillator:

- C₁ — 100- μ fd. variable.
- C₂ — 0.0011- μ fd. zero drift fixed mica.
- C₃ — 250- μ fd. midget mica.
- C₄ — 0.1- μ fd. 200-volt paper.
- C₅ — 0.002- μ fd. midget mica.
- R₁ — 0.25 megohm, $\frac{1}{2}$ -watt.
- R₂ — 0.1-megohm, $\frac{1}{2}$ -watt.
- R₃ — Replace with 2.5-mh. r.f. choke.
- L — 2.1 (2.5) mh. r.f. choke (cathode tap between 1st and 2nd pies above ground).

As I. F. Test Signal Source:

- Same as frequency meter above, except L:
- 440-510 kc.: 140 turns No. 30, close-wound on $1\frac{1}{2}$ -inch form. Cathode tap 35 turns from ground end.
- 1400-1650 kc.: 42 turns No. 20 d.s.c., close-wound on $1\frac{1}{2}$ -inch form. Cathode tap 10 turns from ground end.

Mechanical considerations are most important in the construction of a frequency meter. No matter how good the instrument may be electrically, its accuracy cannot be depended upon if it is flimsily built. Mount everything solidly; make connections with stiff wire and place all leads so they cannot be moved in the course of ordinary handling.

Inherent frequency stability can be appreciably improved by avoiding the use of phenolic compounds and plastics (bakelite, polystyrene, etc.) in the oscillator circuit, employing only high-grade ceramics for insulation. Even ordinary ceramics can usually be improved in this respect by impregnating in high-melting point wax or Victron dope after baking.

It is desirable to design the frequency meter so that the oscillator operates in the 1715-2000-kc. band, with a "spread" such that almost the entire dial scale is used to cover the band. For the higher-frequency bands, harmonics of the oscillator are used.

The signal from the frequency meter can be fed into the receiver by connecting a wire from the output post on the meter to the antenna post on the receiver. If the signal should be too loud, the wire from the output post can be disconnected from the receiver but left in the vicinity of the receiving lead-in.

When the frequency meter is first turned on some little time is required for the tube to reach its final operating temperature; during this period the frequency of oscillation will drift slightly. Although the drift will not amount to more than two or three kilocycles on the 3500-kc. band and proportionate amounts on the other bands, it is desirable to allow the frequency meter to "warm up" for about a half hour before calibrating, or before making measurements in which the utmost accuracy is desired. Better still, the frequency meter can be left on permanently. The power consumption is negligible, and the long-time stability will be vastly improved.

The more elaborate frequency meter shown in Figs. 1706-1708 utilizes a triode oscillator electron-coupled to a pentode multiplier. A high order of frequency stability is attained by keeping the plate and grid coupling to the tuned circuit as small as will permit steady oscillations. Further improvement is had by operating in

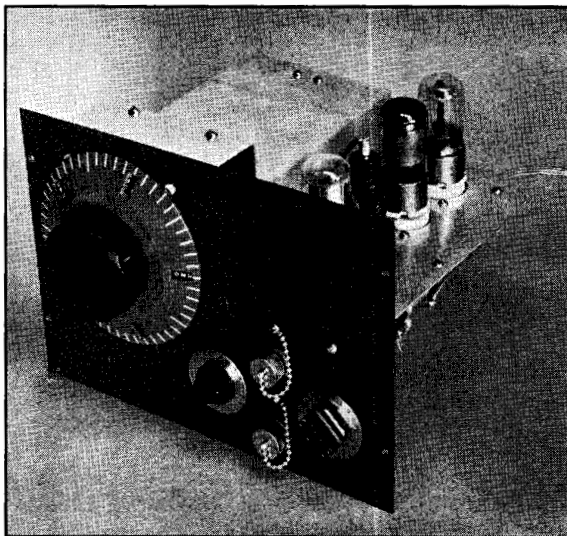
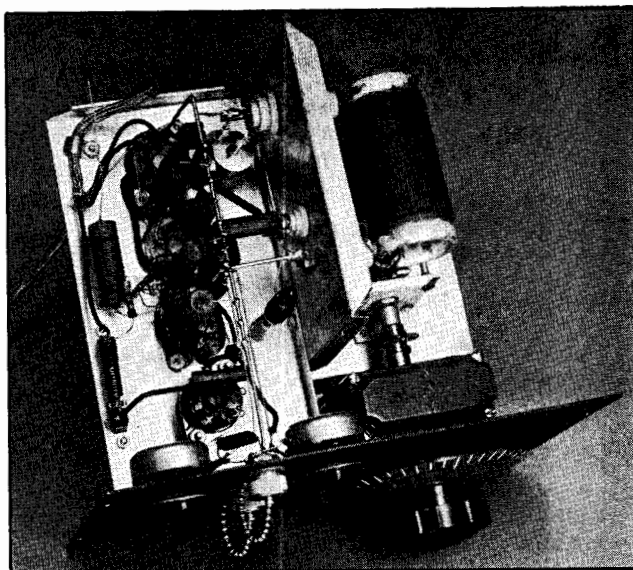

Fig. 1706 — A stable heterodyne frequency meter with separate oscillator and harmonic multiplier. A precision dial, rigid mechanical construction and well-isolated tuned circuit are essentials of the stable heterodyne frequency meter. R.f. output and mixer input terminals, with their respective attenuators, are located on the front panel.

Measurements and Measuring Equipment

Fig. 1708 — Underneath the stable heterodyne frequency meter. The coil and main tuning condenser are in a separate compartment well removed from tube heat. Grid and plate connections to tuned circuit are made through feed-thru insulators, eliminating shaky wire leads. Oscillator tube at rear, followed by multiplier, mixer and regulator (the latter socket is suspended on pillars because of its extra height). All grounds are made to a single bus, reducing stray currents through chassis and limiting radiated output except through panel terminals. Shielded battery cable completes the shielding. Condenser lead at top left goes to headphone jack on rear wall of cabinet.



the frequency band 875–1025 kc., giving both a relatively better tuned circuit and a lower ratio of tube capacitance change to transconductance. Thus variations in the tube conditions have negligible effect, and the ultimate

stability is practically that of the tuned circuit alone.

Temperature effects are minimized by a mechanical arrangement isolating the tuned circuit from tube heat. Humidity effects can be

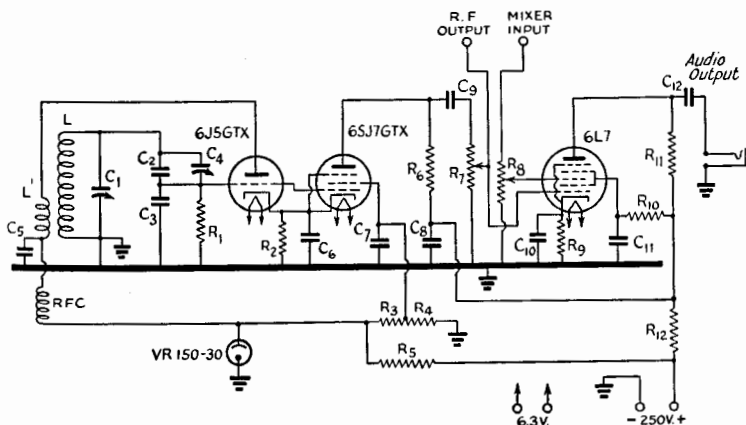

Fig. 1707 — Circuit diagram of the stable frequency meter.

- | | | |
|--|---|---|
| C ₁ — 100- μ fd. double-spaced variable (Hammarlund HFB-100-E). | C ₁₁ — 0.01- μ fd. 400-volt paper. | R ₁₂ — 5000 ohms, $\frac{1}{2}$ -watt. |
| C ₂ — 200- μ fd. zero-drift fixed mica (Centralab 8142). | C ₁₂ — 250- μ fd. midget mica. | RFC — 2.5-millihenry r.f. choke. |
| C ₃ — 0.001- μ fd. zero-drift fixed mica (Sickles Silver-Cap). | R ₁ — 50,000 ohms, $\frac{1}{2}$ -watt (IRC Type F). | L — 72 turns No. 22 d.c.c., close-wound (30 turns per inch) on $\frac{1}{4}$ -inch diameter form (National XR-13) and thoroughly impregnated. |
| C ₄ — 50- μ fd. midget padder (Millen 26050). | R ₂ — 1000 ohms, $\frac{1}{2}$ -watt. | L' — 16 turns No. 22 d.c.c. close-wound on $\frac{1}{4}$ -inch diameter. Winding is placed inside XR-13 form and allowed to spring open, fitting tightly inside form. It is then cemented in place. |
| C ₅ — 0.01- μ fd. 400-volt paper. | R ₃ — 5000 ohms, 1-watt. | Dial — National NPW-0. |
| C ₆ — 0.1- μ fd. 400-volt paper. | R ₄ — 10,000 ohms, 1-watt. | |
| C ₇ — 0.01- μ fd. 400-volt paper. | R ₅ — 10,000 ohms, 10-watt (for 250-volt supply). | |
| C ₈ — 0.05- μ fd. 400-volt paper. | R ₆ — 0.25-megohm, $\frac{1}{2}$ -watt. | |
| C ₉ — 0.001- μ fd. midget mica. | R ₇ — 250,000-ohm potentiometer. | |
| C ₁₀ — 0.1- μ fd. 400-volt paper. | R ₈ — 250,000-ohm potentiometer. | |
| | R ₉ — 500 ohms, $\frac{1}{2}$ -watt. | |
| | R ₁₀ — 75,000 ohms, $\frac{1}{2}$ -watt. | |
| | R ₁₁ — 20,000 ohms, $\frac{1}{2}$ -watt. | |

The Radio Amateur's Handbook

largely eliminated by impregnating the coil with high melting point wax or (after thorough baking) by coating the winding with Victron coil dope.

Ceramic insulation is used throughout the oscillator circuit, even to the tube bases. The construction is made extremely rigid mechanically. When the lips on all faces of the sub-chassis are attached to the walls and bottom of the 8 × 10 × 7-inch metal cabinet, torsional twisting is practically eliminated and vibratory effects are minimized.

Frequency shift through line-voltage changes is eliminated by the use of a VR-150-30 regulator tube.

The oscillator and multiplier receive a common initial bias through R_2 . This bias is such as to approximate cut-off for the 6SJ7, in which condition it serves as an effective doubler without introduction of grid current so long as the r.f. grid swing is properly limited. There is no perceptible reaction upon the oscillator from the multiplier plate circuit.

The output of the multiplier goes first to a shielded output terminal, to be conducted through a shielded line to the receiver or monitor input, with an attenuator to regulate output level. It also goes to the grid of a mixer tube and audio detector which delivers to headphones the audio response resulting from the heterodyne between the frequency meter oscillator and the signal from the transmitter being checked. The transmitter signal is coupled into the mixer through a second shielded terminal.

No on-off switch is provided, since the preferred practice is to keep the meter running constantly.

While the dial shown can be read with good

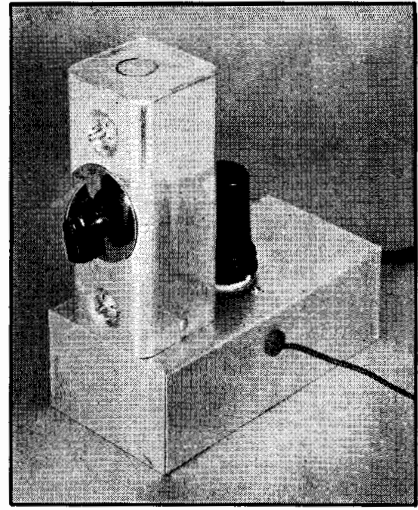

Fig. 1710 — 100-1000-kc. e.c. oscillator.

accuracy to about 1 part in 1000, even greater precision can be had by constructing a vernier scale the length of nine dial divisions but subdivided into ten parts (as on the National Type "N" dial, etc.). With such a vernier, readings can be made at 28 Mc. to within about + or - 1 kc.

100-1000-Kc. E.C. Frequency Standard

Figs. 1709-10 show a simple and easily-constructed electron-coupled oscillator which can be used as a standard with output on 100 or 1000 kc. A complete grid tank circuit for 100 kc. and another for 1000 kc. are provided in a shielded commercial unit, with switch provision for selecting either output frequency. With this arrangement, little remains of assembly and wiring of the frequency standard. Alternatively, an ordinary tuned circuit can be made up as shown under Fig. 1705. An outline of adjustment procedure is given below for convenience:

1. Tune in WWV (see page 262) on a receiver operating on 5 Mc.
2. With the oscillator operating, rotate the tuning control until an audible note is heard in the receiver; adjust carefully for zero beat.
3. To determine whether the harmonic beating with WWV may be some other than the desired harmonic, tune in a station operating on an even multiple of 100 or 1000 kc. (700 kc., 800 kc., 900 kc., etc.). If the broadcast station gives a very low-pitched beat note, the beat of the 100-kc. oscillator's 50th harmonic with WWV is assured. If a high-pitched note is heard, on the other hand, the oscillator should be readjusted

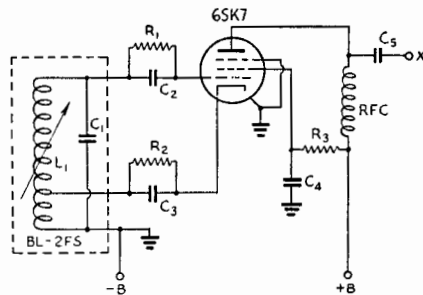

Fig. 1709 — Circuit of the e.c. band-setting oscillator.
 C_1, L_1 — Tank circuits and switch for 100- and 1000-kc. operation, with trimmer adjusting screws for tuning (Browning BL-2FS).
 C_2 — 100- μ fd. fixed mica.
 C_3 — 0.1- μ fd. 200-volt paper.
 C_4 — 0.1- μ fd. 200-volt paper.
 C_5 — 100- μ fd. fixed mica.
 R_1 — 50,000 ohms, $\frac{1}{2}$ -watt.
 R_2 — 300 ohms, 1-watt.
 R_3 — 75,000 ohms, 1-watt.
 RFC — 2.5-mh., 125-ma. r.f. choke.

Measurements and Measuring Equipment

and the process of WWV zero beat and b.c. check should be repeated.

A crystal-controlled version of the 100-1000 kc. oscillator can be built according to Figs. 1711-13. A special X-cut crystal is used which will oscillate at either of two frequencies, one determined by its thickness (1000 kc.) and the other by its length along the mechanical axis (100 kc.), depending on the frequency to which the plate circuit is tuned.

In the unit pictured, a d.p.d.t. toggle switch selects the frequency desired. In the 100 kc. position this switch also connects a small trimmer condenser in parallel with the crystal.

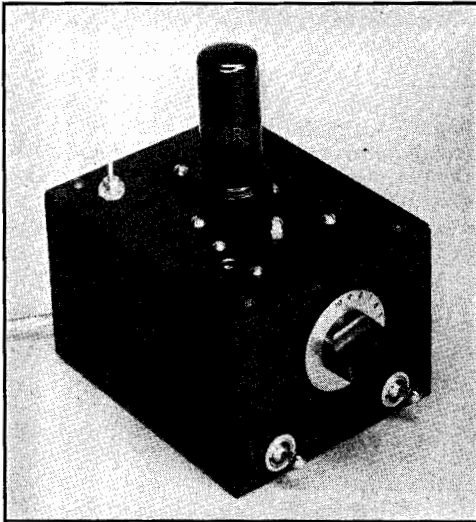

Fig. 1711 — 100-1000-kc. crystal calibrator. Output is taken through the insulated terminal bushing at left rear.

By adjustment of this condenser the frequency of the crystal can be varied in a positive direction, and set to precisely 100 kc. (In purchasing the crystal specify that any error be on the high-frequency side of 100 kc.) An accuracy of but a few parts in a million can thus be attained.

The 1000-kc. frequency has an accuracy of 0.05 per cent. However, since it is used only to indicate approximate 1000 kc. points, its absolute frequency is not important.

The oscillator output is taken through an insulated bushing, from which a connecting lead can be run to the receiver input. *SW*₂ opens the plate supply lead when no signal is wanted; the heater is ordinarily left on continuously to keep the tube at operating temperature.

100-Kc. Secondary Frequency Standard

For highest accuracy in frequency checking and calibration, the most suitable device for

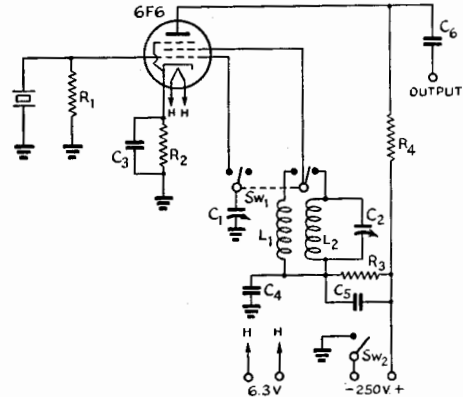

Fig. 1712 — Crystal calibrator circuit diagram.

- C*₁ — 35- μ fd. midget variable (Hammarlund HF-35).
- C*₂ — 100- μ fd. mica trimmer (Hammarlund CTS-85).
- C*₃, *C*₄, *C*₅ — 0.1- μ fd. 400-volt paper.
- C*₆ — 0.001- μ fd. midget mica.
- R*₁ — 5 megohms, $\frac{1}{2}$ -watt.
- R*₂ — 500 ohms, $\frac{1}{2}$ -watt.
- R*₃ — 25,000 ohms, 1-watt.
- R*₄ — 0.25 megohm, $\frac{1}{2}$ -watt.
- L*₁ — 8-mh. r.f. choke (Meissner 19-2078).
- L*₂ — 2.5-mh. r.f. choke (all but one pie removed).
- SW*₁ — D.p.d.t. toggle switch.
- SW*₂ — S.p.s.t. toggle switch.
- Crystal — Bliley SMC-100.

amateur work is a precision crystal-controlled secondary standard, provided with a multi-vibrator for frequency division. Such a standard can be constructed at reasonable cost, and will mark 10-kc. intervals throughout the communications spectrum with a degree of accuracy more than sufficient for all amateur purposes.

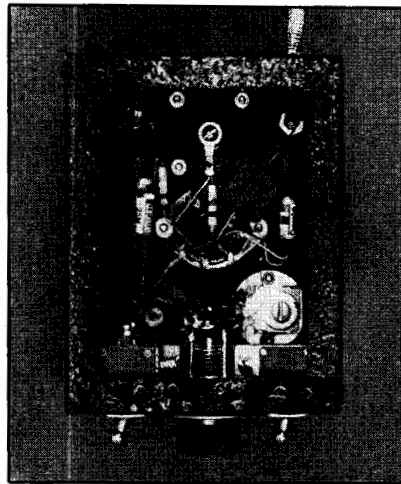

Fig. 1713 — Interior of 100-1000-kc. crystal calibrator. The crystal is mounted at top center, above the socket. Trimmer for 1000-kc. plate circuit at lower right, 8 mh. choke for 100-kc. at lower left.

The Radio Amateur's Handbook

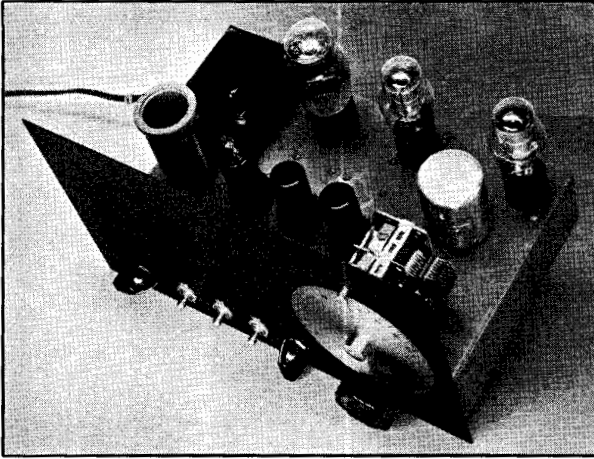

Fig. 1714 — Secondary frequency standard, incorporating a 100-kc. low-drift crystal, 10-kc. multivibrator, and harmonic amplifier-modulator. The vernier dial is used for precise setting of the crystal frequency. Controls along the bottom are, from left to right: output tuning, C_{14} ; on-off switch, S_1 ; "B" switch, S_2 ; multivibrator switch, S_3 , and multivibrator control, R_8 . Power transformer, rectifier and regulator tubes are along the rear edge of the 7-by-12-inch chassis. The crystal oscillator is at the right, multivibrator tube in the center, and output circuit at the left.

A standard of this type is illustrated in Figs. 1714 and 1716. The circuit diagram is given in Fig. 1715. The frequency control is a Bliley SOC-100 unit, consisting of a low-drift 100-kc. bar with an oscillator coil in the same mount-

ing. The oscillator tube is a 6SJ7, used in the circuit recommended for this crystal unit by the manufacturer. The output of the oscillator is coupled to a 6K8 harmonic amplifier through C_8 , and also to the 6SC7 multivibrator (a

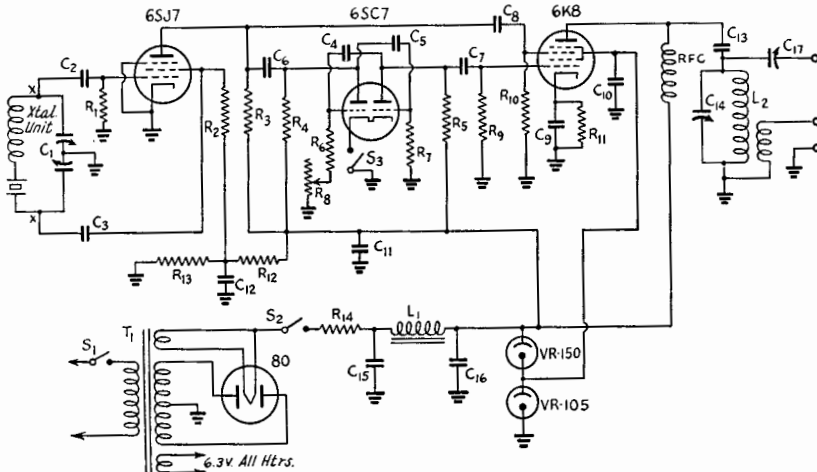

Fig. 1715 — Circuit diagram of the frequency standard.

- | | | |
|--|--|---|
| C_1 — Dual 365- μ fd. variable, compact broadcast type (Meissner 21-5214). | C_{15}, C_{16} — 8- μ fd. 450-volt electrolytic. | R_{11} — 800 ohms, $\frac{1}{2}$ -watt. |
| C_2, C_3 — 0.01- μ fd. 400-volt paper. | C_{17} — 30- μ fd. trimmer (National M-30). | R_{12} — 25,000 ohms, 1-watt. |
| C_4, C_5 — 0.001- μ fd. midget mica. | R_1 — 1 megohm, $\frac{1}{2}$ -watt. | R_{13} — 50,000 ohms, 1-watt. |
| C_6, C_7 — 10- μ fd. midget mica. | R_2, R_3 — 0.5 megohm, 1-watt. | R_{14} — 1500 ohms, 10-watt. |
| C_8 — 50- μ fd. midget mica. | R_4, R_5 — 50,000 ohms, 1-watt. | RFC — 2.5 mh. r.f. choke. |
| $C_9, C_{10}, C_{11}, C_{12}$ — 0.1- μ fd. 400-volt paper. | R_6, R_7 — 20,000 ohms, $\frac{1}{2}$ -watt. | S_1, S_2, S_3 — S.p.s.t. toggle. |
| C_{13} — 0.002- μ fd. midget mica. | R_8 — 15,000-ohm potentiometer. | T_1 — Power transformer, 250 v. d.c. at 40 ma. (Thordarson T13R11). |
| C_{14} — 140- μ fd. variable (Hammarlund HF-140). | R_9 — 0.3 megohm, $\frac{1}{2}$ -watt. | L_1 — 7-henry, 40-ma. filter choke (Thordarson T13C26). |
| L_3 — 550-1200 kc. — 130 turns No. 30 enameled. | R_{10} — 0.1 megohm, $\frac{1}{2}$ -watt. | 32-13.5 Mc. — 5 turns No. 22 enameled, length 1 inch. |
| 1200-3300 kc. — 70 turns No. 22 enameled. | | 56 Mc. — 2 or 3 spaced turns on 1-inch form, or air wound. Adjust for optimum output. |
| 7500-3300 kc. — 22 turns No. 22 enameled, length 1 inch. | | All except 56-Mc. coil wound on $\frac{1}{2}$ -inch forms. |
| 15-6.8 Mc. — 11 turns No. 22 enameled, length 1 inch. | | Output links may be adjusted to give desired signal strength in receiver. |

Measurements and Measuring Equipment

resistance-capacity oscillator of the "relaxation" type) through C_6 . The multivibrator is an unstable oscillator which possesses the property of being readily "locked" in frequency by r.f. energy from a stable source; this locking will occur even when the controlling frequency is a fairly high-order harmonic of the fundamental multivibrator oscillation. In the present case, the multivibrator fundamental is 10 kc. and it is locked by the 100-kc. output of the crystal oscillator. In Fig. 1715, the output of the multivibrator, which consists of 10 kc. plus a series of harmonics, is used to modulate the 6K8 output by coupling to the injection grid, thus giving a series of 10-kc. signals between each pair of 100-kc. harmonics. The oscillator plate in the 6K8 is not used.

The output circuit of the 6K8 is tuned to the particular frequency on which checking is to be done in order to increase the harmonic output at that frequency. Plug-in coils are provided to cover the complete spectrum. The output may be taken either through the small condenser, C_{17} , or a suitable link winding on the coil.

A power supply is incorporated in the unit, with its output voltage regulated by means of the VR-150-30 and VR-105-30 tubes. Voltage regulation prevents changes in oscillator frequency with varying line voltage.

The crystal frequency can be adjusted to precisely 100 kc. by means of C_1 . This adjustment should be made by beating the output on 5000 kc. against the continuous transmissions on this frequency from WWV. After a warm-up period of 15 minutes or so, the frequency should stay within a few cycles of WWV over considerable periods of time. The multivibrator can be cut out of the circuit by means of S_3 when

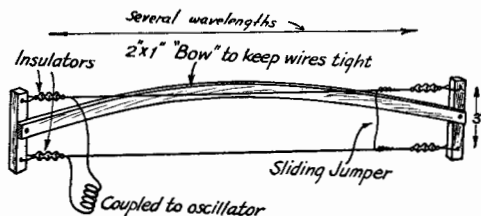

Fig. 1717 — Lecher wire system.

only 100-kc. points are wanted. Switching the multivibrator on or off will cause a frequency change of less than one part in a million.

A "B" switch, S_2 , is provided so that the unit may be made inoperative without cutting off the heater voltage.

For checking 1000-kc. points, a coil of about 150 microhenrys (a $1\frac{1}{2}$ -inch winding of No. 30 d.c.c. on a $1\frac{1}{2}$ -inch form) may be substituted for the crystal unit, connected between points X-X in the diagram. With C_1 near maximum capacity, the circuit will tune to 1000 kc. The exact frequency may be set by adjusting so that the 5th harmonic coincides with WWV, or so that the fundamental is at zero-beat with a broadcast station on 1000 kc.

● U. H. F. FREQUENCY CHECKING BY LECHER WIRES

The methods described for checking transmitter frequency on the lower frequency bands are often unsuited for use on the ultra-high frequencies. The methods that are simplest and most satisfactory in this region are based on direct measurement of the physical characteristics of resonant linear circuits.

The simplest method is to cut the antenna wire to 95 per cent of the actual wavelength desired, then tuning the transmitter until the antenna is operating most effectively. This is, of course, extremely approximate and would serve only as a preliminary measure.

The next simplest scheme is to compare the frequency of one's own transmitter by listening to it on the receiver and comparing the setting with other stations of known wavelength. This is readily possible in districts where plenty of signals are available for the purpose. The problem is readily solved if a linear type oscillator is used. With this type of oscillator (described in Chapter 29) the wavelength can be measured approximately from the rods which constitute the tuning circuit.

For the very short waves, probably the most practical method in-

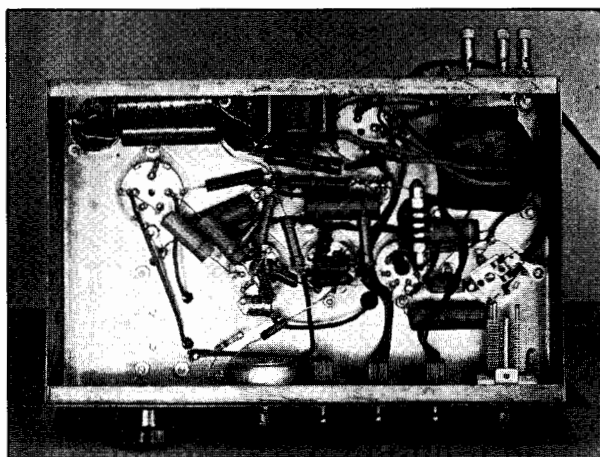

Fig. 1716 — Bottom view of the frequency standard. Reasonable care should be used to keep the circuits separated and leads short, but there are no critical wiring points. The filter choke is mounted on the rear edge of the chassis.

The Radio Amateur's Handbook

volves the use of two parallel wires — known as Lecher wires — on which standing waves may be measured directly. Such a Lecher system may be set up readily. It forms a valuable addition to the ultra-high frequency worker's equipment.

A typical Lecher system (Fig. 1717) consists of two No. 18 bare copper wires spaced about three inches and mounted on stand-off insulators on a length of board. The wires should be several wavelengths long. The wires are left free at one end while at the other they are connected to a one- or two-turn coupling coil of about the diameter of the tank coil of the transmitter. This coupling coil is placed near the transmitter coil. In operation, a sliding bridge — consisting of a piece of stiff bare wire on the end of a two-foot wooden dowel — is run slowly down the length of the wires until a point is reached where the oscillator plate current makes a sudden fluctuation. The point is marked. The bridge is then moved farther down the wires until a second node is located. This also is marked. The same procedure is then followed to locate a third node. At this stage, the distance between each pair of marks is measured. If the Lecher system is operating correctly and if it is mounted well clear of surrounding objects, the distances will all be the same and will represent quite accurately one half of the wavelength being measured. An alternative sliding bridge — useful when the oscillator has plenty of output — is a flash-lamp bulb with wires soldered to its contacts. These wires are hooked over the wires of the Lecher system and the lamp moved along until the various points are located at which the

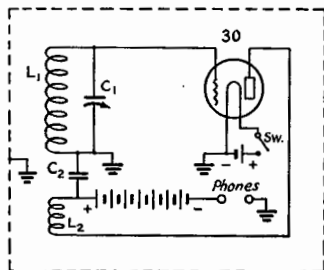

Fig. 1718 — Simple monitor.

- C_1 — 50- μ fd. midget variable condenser.
 C_2 — .002- μ fd. midget mica condenser.
 Sw — Single-pole toggle switch.
 L_1, L_2 — Wound on 1½-inch 4-pin forms with No. 30 d.s.c. wire. The number of turns is given in this table:

Band	L_1	L_2
1750 kc.	70	20
3500 kc.	35	10
7000 kc.	15	6
14,000 kc.	5	4

The monitor can be built in any metal container large enough to hold it, a small-size 22½-volt "B" battery, and a flashlight cell.

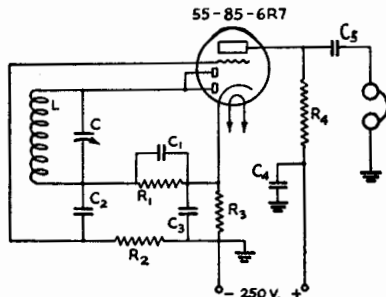

Fig. 1719 — Simple 'phone monitor.

- C_1 — 250- μ fd. mica. R_1 — .5 megohm ½-watt.
 C_2 — 0.01- μ fd. 200-volt. R_2 — 2-megohm ½-watt.
 C_3 — 0.1- μ fd. 200-volt. R_3 — 3500-ohm ½-watt.
 C_4 — 0.002- μ fd. 400-volt. R_4 — .1-megohm ½-watt.
 C_5 — 1- μ fd. 400-volt.

lamp lights brightest. The points will be extremely critical.

The same general procedure may be used to calibrate a receiver — the indication in this case being obtained by the receiver going out of oscillation as the bridge passes over the various nodes.

Once the approximate calibration has been obtained in this way, it can be checked by comparing harmonics produced by oscillators on harmonically-related lower frequency bands.

● MONITORS FOR C.W.

Aside from current-indicating instruments, one of the most useful instruments the station can have is a monitor, used for checking the quality of the emitted signal.

A monitor is a miniature receiver, usually having only a single tube, enclosed with its batteries in some sort of metal box which acts as a shield. It need not be a costly or elaborate affair. The circuit shown in Fig. 1718 illustrates the simplicity of a typical monitor.

The requirements for a satisfactory monitor for checking c.w. signals are not difficult to satisfy. It should oscillate steadily over the bands on which the station is to be active; the tuning should not be excessively critical, although the degree of band-spreading ordinarily considered desirable for receivers is not essential; the shielding should be complete enough to permit the monitor to be set near the transmitter and still give a good beat note when tuned to the fundamental frequency of the transmitter (this is often impossible with the receiver because the pick-up is so great); and it should be constructed solidly enough so that it can be moved around the station without necessity for retuning when listening to a signal.

Monitors for 'Phone

Any type of simple detector circuit with a means for picking up a small amount of r.f.

Measurements and Measuring Equipment

from the transmitter can be used as a 'phone monitor. The pickup coil need not even be tuned, although the monitor will be considerably more sensitive when tuned.

A satisfactory type of 'phone monitor, using a duo-diode-triode tube as a diode detector and audio amplifier, is shown in Fig. 1719. The circuit LC is tuned to the transmitter frequency; any constants which satisfy this requirement can be used.

Because of the tuned pickup and audio amplification, a monitor of this type will be quite sensitive. Besides its primary use for audio quality checks, it can be used for checking hum and other carrier noises.

The 'phone monitor usually must be used with a headset, since a loud-speaker will cause audio feed-back through the microphone.

● D.C. INSTRUMENTS

Throughout this *Handbook* reference has been made to the use of direct-current instruments for measurement of current and voltage. Voltmeters and ammeters are basically

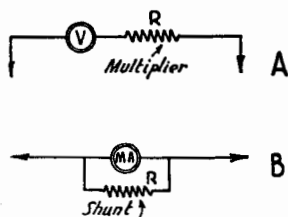

Fig. 1720 — How voltmeter multipliers (A) and milliammeter shunts (B) are connected.

identical instruments, the difference being in the method of connection. A voltmeter is an ammeter which measures the current through a high resistance connected across the source to be measured; its calibration is in terms of voltage drop in the resistance, or *multiplier*. An ammeter is connected in series with the circuit and measures the current flow. The ranges of both voltmeters and ammeters can be extended by the use of external resistors, connected in series with the instrument in the case of a voltmeter or in shunt in the case of an ammeter. Most ammeters used in radio work measure in thousandths of amperes, and are called milliammeters.

Shunt and series multipliers for meters are usually highly accurate precision resistors, so that they will not contribute error to the meter reading. Ordinary carbon resistors, selected for accuracy, can also be used when economy is a consideration.

The ways in which multipliers and shunts are connected to voltmeters and milliammeters are shown in Fig. 1720. To calculate the value of multiplier or shunt it is necessary to know the

resistance of the meter; this information can be obtained from the maker. If it is desired to extend the range of a voltmeter, the value of resistance which must be added in series is given by the formula:

$$R = R_m (n - 1)$$

where R is the multiplier resistance, R_m the resistance of the voltmeter, and n the scale multiplication factor. For example, if the range of a 10-volt meter is to be extended to 1000 volts, n is equal to $1000/10$ or 100.

If a milliammeter is to be used as a voltmeter, the value of series resistance can be found by Ohm's law, or

$$R = \frac{1000 E}{I}$$

Where E is the desired full-scale voltage and I the full-scale current reading of the instrument in milliamperes.

To increase the current range of a milliammeter, the resistance of the shunt, Fig. 1720-B, can be found from the formula:

$$R = \frac{R_m}{n - 1}$$

where the letters have the same significance as before.

Homemade milliammeter shunts can be constructed from any of the various special kinds of resistance wire, or from ordinary copper magnet wire if no resistance wire is available. Reference to the Copper Wire Table in Chapter 20 will give the resistance per 1000

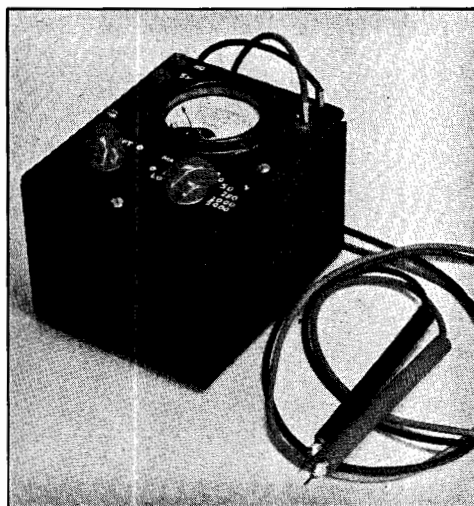

Fig. 1721 — The inexpensive multi-range volt-ohm-milliammeter is housed in a standard 3 x 4 x 5 metal cabinet. Ranges are marked with number dies, the impressions being filled with white ink. High-voltage test leads are available for use on the 5000-volt range.

The Radio Amateur's Handbook

feet of various sizes of wire. After determining the resistance required by the formula above, measure off enough wire (pulled tight but not stretched) to provide the required resistance. Accuracy can be checked by causing a current flow through the meter that makes it read full-scale *without* the shunt; connecting the shunt should then give the correct reading based on the new full-scale range.

Multi-Range Voltmeters and Ohmmeters

A combination voltmeter-milliammeter having various ranges is extremely useful for experimental purposes and for trouble-shooting in receivers and transmitters. As a voltmeter such an instrument should have high resistance

cuit. For such purposes a 1000-ohms-per-volt instrument is customarily used; a 0-1 milliammeter or 0-500 microammeter (0-0.5 ma.) is the basis of most multi-range meters of this type. Microammeters having a range of 0-50 μ a., giving a sensitivity of 20,000 ohms per-volt, are also used.

The various current ranges on a multi-range instrument can be obtained by using a number of shunts individually switched in parallel with the meter. Great care should be taken to minimize contact resistance.

It is often necessary to check the value of a resistor or to find the value of an unknown resistance, particularly in receiver servicing. For this purpose an "ohmmeter" is used. An

Fig. 1722 — Circuit of the low-cost V-O-M.

- R₁ — 2000-ohm wire-wound variable resistor.
- R₂ — 3000 ohms, ½-watt.
- R₃ — 100-ma. shunt, 0.33 ohms (see text).
- R₄ — 10-ma. shunt, 3.6 ohms (see text).
- R₅ — 40,000 ohms, ½-watt.
- R₆ — 4 megohms, 4 watts (four 1-megohm 1-watt resistors in series).
- R₇ — 0.75 megohm, 1-watt (two ½-watt resistors in series, 0.5 megohm and 0.25 megohm).
- R₈ — 0.2 megohm, ½-watt.
- R₉ — 40,000 ohms, ½-watt.
- R₁₀ — 10,000 ohms, ½-watt.
- SW — 9-point 2-pole switch (Mallory-Yaxley 3109).
- B — 4.5 volts (Burgess 5360).
- MA — Triplett 0-1 ma., type 221.

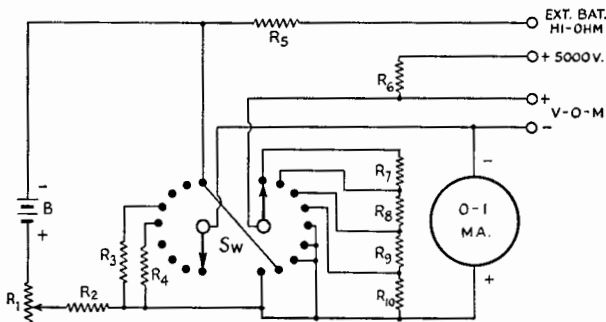

so that very little current will be drawn in making voltage measurements. A voltmeter taking considerable current will give inaccurate readings when connected across a high-resistance source, as is often the case in checking voltages at various parts of a receiver cir-

cuit. An ohmmeter is simply a low-current d.c. voltmeter provided with a source of voltage (usually dry cells), connected in series with the unknown resistance. If a full-scale deflection of the meter is obtained with the connections to the external resistance shorted, insertion of the resistance under measurement will cause the reading to decrease with the amount of resistance inserted. The scale can therefore be calibrated in ohms. If a voltmeter not calibrated directly in resistance values is used, the following formula can be applied:

$$R = \frac{eR_m}{E} - R_m$$

where R is the resistance under measurement, E is the voltage read on the meter, e is the series voltage applied, and R_m is the internal resistance of the meter (full-scale reading in volts \times ohms-per-volt).

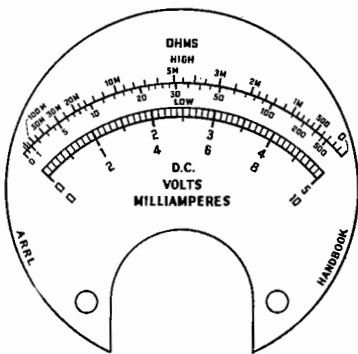

Instrument scale for inexpensive volt-ohm-milliammeter, to be cut out and pasted over existing scale of Triplett No. 221 0-1 ma. milliammeter or any equivalent 2-inch meter with 33 ohms internal resistance. Calibration should be checked with standard of moderate accuracy after assembly, to allow for variations in individual meters, inaccuracies in multipliers, resistance of test leads, paper shrinkage, etc.

A number of excellent commercial kits for the construction of multi-range meters of the type used largely by service men are on the market. There are also excellent but not expensive combination meters available designed particularly for amateur work. A good, versa-

Measurements and Measuring Equipment

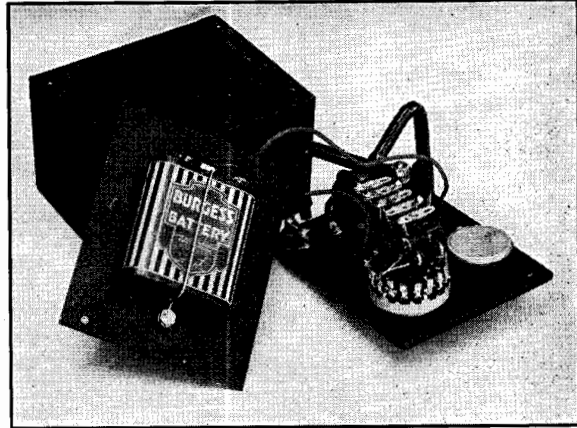

Fig. 1723 — Interior of low-cost volt-ohm-milliammeter. All parts except the internal ohmmeter battery are mounted on the 4 x 5-inch bakelite panel. The battery is attached to the bottom plate. Voltmeter multiplier is first assembled on insulated tie strip, then wired into circuit. M-shaped object in rear is 5000-volt multiplier — four 1-watt resistors covered with varnished cambric tubing. Milliammeter multipliers can be seen in front center.

tile instrument of this sort will prove its worth many times over in the amateur station.

A combination multi-range volt-ohm-milliammeter, reduced to its simplest and least expensive terms, is shown in Figs. 1721-23. Using a 0-1 ma. meter, the voltmeter has five ranges at 1000 ohms per volt: 0-10, 50, 250, 1000 and 5000 volts. In addition to the basic 0-1 ma., current ranges of 0-10 and 100 ma. are provided. There are two resistance measurement ranges (three with external battery): a series range of 0-250,000 ohms, and a shunt range of 0-500 ohms. The high-ohms scale can be multiplied by 10 if the plus terminal of a 45-volt battery is connected to the terminal provided (the unknown resistance being connected between the negative battery terminal and ohmmeter).

For reasons of economy, ordinary carbon resistors are used as voltmeter multipliers. These can be obtained with an accuracy of 5 per cent or better; many dealers will allow a selection from stock if maximum accuracy is desired.

The 5000-volt multiplier is made up of four 1-watt resistors, encased in heavy varnished cambric tubing to protect against flashovers. The tubing extends down over the positive "5M" terminal, which is further insulated by a liberal wrapping of friction tape.

The 10-ma. and 100-ma. shunts are made by using ordinary copper magnet wire wound on short lengths of $\frac{1}{4}$ -inch bakelite rod, with pig-tail leads.

● VACUUM-TUBE VOLTMETERS

In the measurement of audio-frequency and radio-frequency voltages, where the use of a power-consuming measuring device is unsatisfactory because of the small power in the circuit, the vacuum-tube voltmeter finds wide application. Most vacuum-tube voltmeters used by amateurs measure peak voltages. The voltmeter tube, which may be a triode or

screen-grid type, is biased nearly to plate current cut-off, a current of a fraction of a milliampere being taken as a reference, called the "false zero." When a voltage is applied between grid and cathode the plate current will rise; the grid bias voltage is then increased until the plate current returns to the false zero. The additional bias voltage required to bring the plate current back to the reference value will be equal to the peak value of the signal being measured. Because the measurements of the peak voltmeter are substantially independent of wave-form, this type of voltmeter is useful in audio and radio-frequency measurements since the capacities of vacuum tubes are determined by the peak voltages and currents which must be handled. A simple but entirely practical voltmeter of this type is shown in Fig. 1724. It is known as the "slide-back" type. In operation, R_1 is turned all the way to the right, with zero reading on the voltmeter V . R_2 is then adjusted until the desired "false zero" point is read on the milliammeter N . The voltage to be measured is then applied, causing the milliammeter reading to increase. R_1 is then adjusted until false zero again is read on M , whereupon the voltmeter will read the voltage being measured. If the voltage to be measured is greater than 9 volts, additional bias can be placed at the point marked X , the exact value being read by an auxiliary voltmeter.

Another common form of simple vacuum-tube voltmeter is the r.m.s. type, utilizing a diode rectifier. The indicator portion of the absorption frequency meter shown in Fig. 1704 is of this type. If R_1 is increased to 0.25-megohm, any a.c. or r.f. voltage can be read without appreciable circuit loading or frequency error. The meter can be calibrated from 60-cycle a.c. if desired. It should be remembered that the readings are r.m.s., or 0.707 times peak values in the case of a sine wave.

The Radio Amateur's Handbook

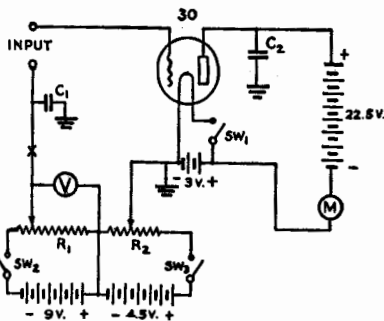

Fig. 1724—Simple peak-type slide-back vacuum-tube voltmeter.

- C₁—500- μ fd. mica fixed condenser.
- C₂—0.01- μ fd. mica fixed condenser.
- R₁—2000-ohm wire-wound potentiometer.
- R₂—1000-ohm wire-wound potentiometer.
- SW_{1,2,3}—Battery on-off switches; may be ganged.
- M—0-1 milliammeter (any low-range milliammeter or microammeter may be used).
- V—0-10 voltmeter, 1000 ohms per volt.

A diode-rectifier voltmeter of this type is especially useful as a neutralization indicator, since it is much more sensitive to r.f. than neon bulbs, etc.

● FIELD-STRENGTH METERS

A useful item in the equipment of the advanced radio amateur is the field-strength meter. Its uses are numerous, the more important being the ability it lends correctly to adjust antenna and transmitter characteristics under actual radiating conditions. This facility is of particularly great importance on the ultra-high frequencies, where an effective field-strength meter represents about the only reliable method of adjustment, especially on low-power equipment or with directive antennas.

The absorption frequency meter with diode-voltmeter indicator shown in Figs. 1703-04 can be used as a field strength meter, if it is provided with a pick-up antenna. An inexpensive collapsible automotive-type antenna, working against ground (chassis), can be used. A few turns of wire wound around the proper coil for the frequency in use will serve to couple the antenna to the tuned circuit. The microammeter scale will read approximately linearly with voltage, a characteristic that is advantageous in making certain types of comparative measurements. Radiated power variations will, of course, be as the square of the field voltage indication. Readings should always be made at distances of several wavelengths from the antenna.

A simple field strength meter particularly suitable for work in the ultra-high frequency region is shown in Fig. 1725. Essentially, the meter consists of an acorn triode operated with very low plate voltage and biased

to cut-off, constituting a linear detector. When the signal under observation is tuned in, rectification occurs, and the plate current increment is read on the microammeter. Among the uses to which this meter can be put are: (1) Measuring comparative transmitter outputs under different adjustments. (2) Neutralizing amplifiers (using only a pick-up coil, without the antenna). (3) Measuring comparative antenna radiation under different adjustments. (4) Deriving field-strength patterns of, and adjusting, u.h.f. beam antennas.

A more sensitive field-strength meter of use in examining the field-strength patterns of lower-frequency antenna systems is shown in Figs. 1726-27. It consists of a diode rectifier and d.c. amplifier in the same envelope. The initial plate current reading is in the neighborhood of 1.4 milliamperes; with signal input, the current dips downward. The scale reading is linear with signal voltage. With a 1.5-milliamperere meter, field strengths of fractional millivolts register on the meter, if a copper-rod antenna two or three feet long is used.

● INTERMEDIATE FREQUENCY TEST OSCILLATOR

An oscillator built according to Fig. 1705 can be used to provide a means of obtaining a strong and steady signal for alignment of the i.f. amplifier stages of low- and high-frequency superheterodynes. Without an oscillator, such alignment becomes a slow and difficult task,

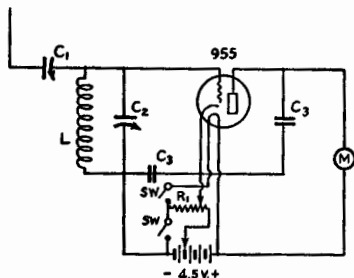

Fig. 1725—Simple field-strength meter.

- C₁—30- μ fd. adjustable mica trimmer condenser.
- C₂—35- μ fd. midget air trimmer condenser.
- C₃—250- μ fd. midget mica fixed condenser.
- R₁—1000-ohm midget potentiometer.
- L—50-80 Mc.: 7 turns No. 14 tinned wire, $\frac{1}{2}$ -inch dia. 1-inch long.
- 25-40 Mc.: 10 turns No. 14 tinned wire, $\frac{3}{4}$ -inch dia. 1-inch long.
- 12-20 Mc.: 20 turns No. 16 enamel wire, close-wound on $\frac{3}{4}$ -inch diameter bakelite tubing.
- 6-10 Mc.: 37 turns No. 22 enamel wire, close-wound on $\frac{3}{4}$ -inch tube.
- 3-5 Mc.: 75 turns No. 30 d.s.c. wire, close-wound on $\frac{3}{4}$ -inch tube.
- 1.5-2.5 Mc.: 75 turns No. 30 d.s.c. wire, close-wound on 2-inch tube.
- M—0-200 microamperes (a higher-range meter, although not as satisfactory, can be used).

Measurements and Measuring Equipment

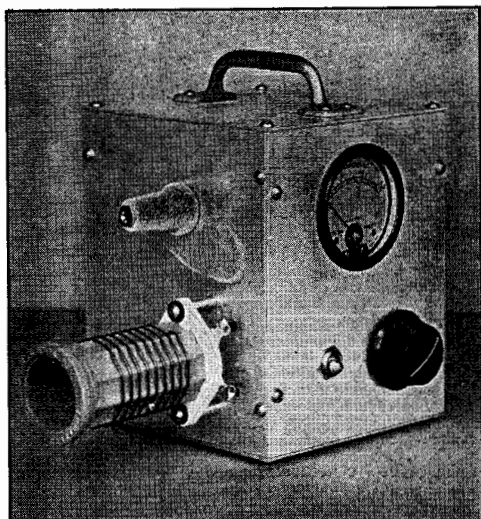

Fig. 1726 — Sensitive field-strength meter. This meter is particularly useful on the lower-frequency amateur bands; it can be used for both transmitter and antenna adjustment, and in making field-strength patterns.

and is often left at an unfinished and unsatisfactory state.

The test oscillator should be shielded rather carefully so that direct pickup from the coil is eliminated. Ordinarily, there is no requirement for calibration of the oscillator, since most

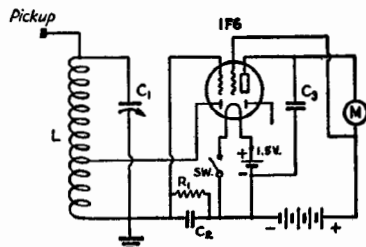

Fig. 1727 — The two-stage field-strength meter circuit diagram.

- C₁ — 50- μ fd. midget variable condenser.
- C₂ — 250- μ fd. midget mica fixed condenser.
- C₃ — 0.002- μ fd. midget mica fixed condenser.
- R₁ — 1-megohm $\frac{1}{2}$ -watt fixed resistor.
- L — Wound on $1\frac{1}{2}$ -inch coil forms, winding length $1\frac{1}{2}$ inches, diode tap in center of coil:
 - 1.5–3 Mc.: 58 turns No. 28 d.s.c. wire, close-wound.
 - 3–6 Mc.: 29 turns No. 20 enamel wire, close-wound.
 - 6–12 Mc.: 15 turns No. 20 enamel wire, spaced.
 - 11–22 Mc.: 8 turns No. 20 enamel wire, spaced.
 - 20–40 Mc.: 4 turns No. 20 enamel wire, spaced.
 - (Above ranges are approximate only.)
- M — 0–1.5 milliamperes.

The filament battery consists of two flashlight cells wired in parallel. The plate battery is a small portable "B" battery, Burgess type Z30P.

Care should be taken to connect the diode plate on the negative filament leg, otherwise an initial bias will be placed on the rectifier and it will not function properly.

superheterodynes are equipped with a crystal filter, so that the crystal of the receiver will determine the frequency at which the oscillator will be operated.

Essentially, this i.f. test oscillator consists of a simple e.c.o. unit with two plug-in coils and a high-*C* padded tuning circuit. Only relatively narrow ranges are provided by the tuning condenser used, since the intermediate frequencies of communication receivers are fairly uniformly fixed in the neighborhoods of 460 kc. and 1600 kc.

If a modulated signal is desired from the oscillator, the positive plate supply connection may be made to the power supply at the output of the rectifier rather than at the usual filter output terminal.

For alignment of the r.f. and oscillator circuits, the same oscillator can be made to serve, with plug-in coils covering the various amateur bands. Alternatively, harmonics from the frequency meter can be used; an isolating amplifier and attenuator in the frequency meter are desirable for this application.

● AUDIO TEST OSCILLATOR

For most adjustments on 'phone transmitters it is desirable to have some form of constant-voltage, adjustable-frequency sine-wave source of a.f. voltage.

A simple and inexpensive device fulfilling these requirements is shown in Figs. 1728 and 1729. A dual triode is used as a simple sine-wave audio oscillator of the capacity-feedback type. Six frequencies are provided — roughly 100, 400, 1000, 3000, 5000 and 10,000 cycles — with standard capacities and inductances. An output control varies the level from zero to the maximum (depending on loading and plate voltage) of several volts.

● CATHODE-RAY OSCILLOSCOPES

Perhaps the most useful of all measuring and testing devices is the cathode-ray oscilloscope.

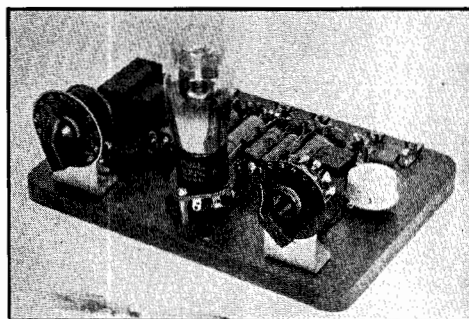

Fig. 1728 — Twin-triode audio oscillator for adjusting 'phone transmitters and audio systems. Construction is simplified by attaching all condensers and resistors to tie strips and wiring between terminal lugs.

The Radio Amateur's Handbook

Although relatively expensive, its applications are so numerous that it can be used to replace a number of other less satisfactory types of measuring equipment. It is particularly suited to r.f. and a.f. voltage measurements because it does not consume power from the source being measured.

The circuit diagram of a simple cathode-ray oscilloscope is given in Fig. 1731. In building such a unit one precaution, in particular, must be observed: the tube must be placed so that the alternating magnetic field from the transformer has no effect on the electron beam. Fig. 1732 shows the placement of the power transformer and cathode-ray tube used in this 'scope to prevent electro-magnetic coupling between transformer and electron beam of tube. The transformer is directly behind the base of the c.-r. tube with axis of transformer winding and axis of tube common.

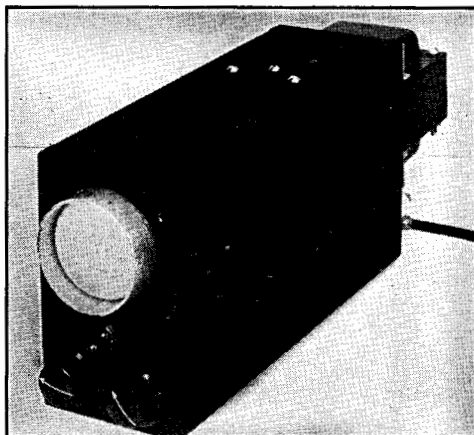

Fig. 1730 — Oscilloscope using 902 2-inch tube, housed in a 5 x 10 x 3-inch chassis with bottom plate.

Fig. 1731 — Circuit of the simple 2-inch oscilloscope.

- C — 2- μ fd., 900-volt working electrolytic (Cornell-Dublier JR-544 with sections series-connected).
- R₁ — 100,000-ohm potentiometer (Centralab Midget).
- R₂ — 50,000-ohm, 1-watt carbon.
- R₃ — 200,000-ohm, 2-watt carbon.
- R₄ — 100,000-ohm, potentiometer with switch (Centralab Midget).
- RFC — 2.5-mh., 125-ma. r.f. choke, optional (for correcting leaning patterns due to r.f. coupling).
- SW₁ — S.p.d.t. toggle switch, 250-volt, 1-amp. rating.
- SW₂ — Potentiometer switch (s.p.s.t.) on R₄.
- T — Receiver-type power transformer delivering 325-0-325 v.a.c. at 40 ma., 5 volts at 3 amp., 6.3 volts at 2 amp. (Thorndarson T-13R11).

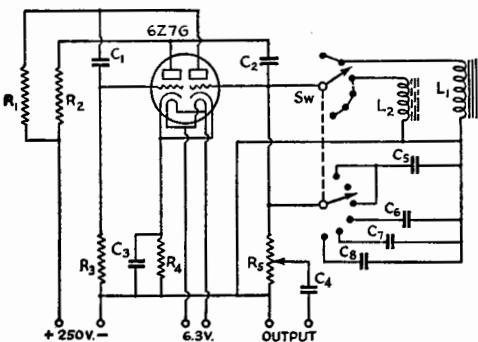
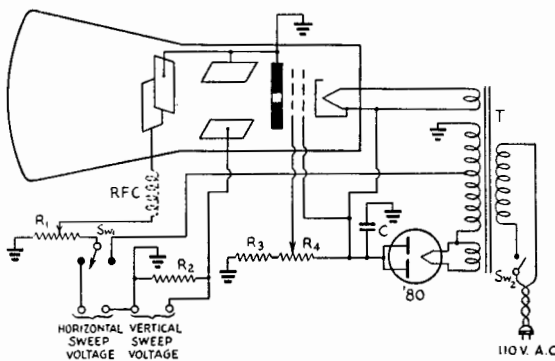

Fig. 1729 — Audio signal generator circuit diagram.

- C₁, C₂, C₄, C₅ — 0.1- μ fd. 400-volt tubular paper.
- C₃ — 10- μ fd. 25-volt tubular electrolytic.
- C₆ — 0.01- μ fd. 400-volt tubular paper.
- C₇ — 0.002- μ fd. midget mica.
- C₈ — 0.0005- μ fd. midget mica.
- R₁, R₂ — 50,000-ohm, $\frac{1}{2}$ -watt.
- R₃ — 0.3-megohm, $\frac{1}{2}$ -watt.
- R₄ — 1000-ohm, $\frac{1}{2}$ -watt.
- R₅ — 50,000-ohm potentiometer.
- L₁ — 7-henry iron-core reactor (Thorndarson T-13C26).
- L₂ — 125-mh. iron-core r.f. choke.

No intensity control provision is made in this oscilloscope — it is operated at maximum at all times. Accordingly, it is quite important that some provision be included for switching off the electron beam, reducing the spot intensity, or swinging the beam to one side of the scope with d.c. bias during periods of no transmission, when the pattern would be confined to a thin, bright line or a small spot of high intensity. This must be done to prevent "burning" the screen of the c.-r. tube.

If trouble is experienced in getting a pattern from a high-power transmitter because of r.f. voltage on the 110-volt supply line, two blocking condensers, 0.01- to 0.1-microfarad, may be connected in series across the primary of the power transformer in the 'scope with their common tap grounded to the metal case.

The cabinet is in reality a 3- by 5- by 10-inch crackle-finished steel chassis with bottom cover plate — all turned up on one edge for greater compactness and improved appearance. The shielding provided by this box is highly desirable for prevention of stray-field interference in the patterns obtained.

Measurements and Measuring Equipment

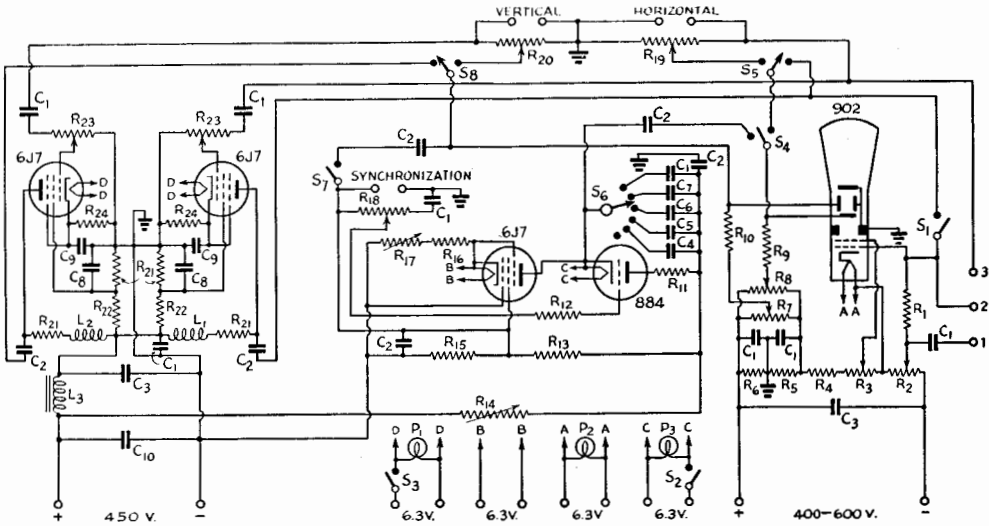

Fig. 1733 — Complete circuit diagram of sweep-circuit oscilloscope.

- C₁ — 0.1- μ fd. 600-volt paper.
- C₂ — 0.25- μ fd. 600-volt paper.
- C₃ — 8- μ fd. 500-volt electrolytic.
- C₄ — 0.0001- μ fd. 400-volt paper.
- C₅ — 0.001- μ fd. 400-volt paper.
- C₆ — 0.005- μ fd. 400-volt paper.
- C₇ — 0.025- μ fd. 400-volt paper.
- C₈ — 0.01- μ fd. 400-volt paper.
- C₉ — 5- μ fd. 25-volt (electrolytic).
- C₁₀ — 16- μ fd. (8-8 parallel) 500-volt electrolytic.
- R₁ — 300,000 ohms, $\frac{1}{2}$ -watt.
- R₂ — 25,000 ohms, 1-watt.

- R₃ — 50,000 ohms, 1-watt.
- R₄ — 75,000 ohms, 1-watt.
- R₅, R₆ — 30,000 ohms, 1-watt.
- R₇, R₈ — 1-meg. potentiometer.
- R₉, R₁₀ — 5-meg. $\frac{1}{2}$ -watt.
- R₁₁ — 1000 ohms, 1-watt.
- R₁₂ — 300,000 ohms, 1-watt.
- R₁₃ — 40,000 ohms, 1-watt.
- R₁₄ — 50,000-ohm wire-wound rheostat.
- R₁₅ — 6000 ohms, 2-watt.
- R₁₆ — 1500 ohms, 1-watt.
- R₁₇ — 50,000-ohm rheostat.

- R₁₈ — 500,000-ohm potentiometer.
- R₁₉, R₂₀ — 5-megohm potentiometer.
- R₂₁ — 100,000 ohms, 1-watt.
- R₂₂ — 150,000 ohms, 1-watt.
- R₂₃ — 500,000-ohm potentiometer.
- R₂₄ — 1000 ohms, $\frac{1}{2}$ -watt.
- S₁, S₂, S₃ — S.p.s.t. toggle.
- S₄, S₅, S₆ — S.p.d.t. toggle.
- S₇ — Snap switch mounted on R18.
- L₁, L₂ — 25-mh. choke.
- L₃ — 30-henry 15 ma. choke.
- P₁, P₂, P₃ — Jeweled pilot lamps.

In this oscilloscope the horizontal sweep voltage can be obtained either from an audio-frequency source (such as the modulator stage of a transmitter) or from the 60-cycle line. Using an a.f. horizontal sweep, the pattern appearing on the screen will be in the form of a trapezoid or triangle (depending on the percentage of modulation) when checking transmitter performance. Practical application of this method is outlined in Chapter 16.

Although for many amateur applications the use of a sweep circuit having a linear time base

is not essential, for actual studies of wave form the linear time axis is necessary. The sweep circuit proper usually employs a grid-controlled gaseous discharge tube, the 884 (especially designed for this purpose), operating as a relaxation oscillator. In operation, the sweep circuit is connected to the horizontal-deflection plates of the existing oscilloscope. The voltage under observation is connected to the vertical-deflection plates, and the resulting picture is an accurate representation of the wave shape of the voltage being examined.

Fig. 1732 — Side view of the 2-inch 'scope with cover removed. In this view can be seen the mounting of the cathode-ray tube, and rectifier for easy connection to the flexible leads of the power transformer. Two small feed-through insulators serve as terminals for external horizontal- and vertical-sweep connection, while a machine screw through the rear of the chassis serves as the common ground terminal. Note the location of the power transformer not only outside the steel shield chassis but also directly behind the c.-r. tube, with the axis of the transformer winding along the axis line of the tube.

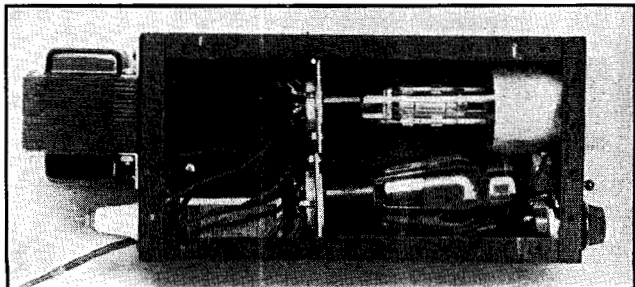

The Radio Amateur's Handbook

WWV SCHEDULES

5000 kc.: Continuously, with 440-cycle tone modulation, except during special broadcast periods noted below.

SPECIAL BROADCASTS

5000 kc.: Tuesday, Wednesday and Friday, 10:00 A.M. to 11:30 A.M., E.S.T.

10,000 kc.: Tuesday, Wednesday and Friday, Noon to 1:30 P.M., E.S.T.

20,000 kc.: Tuesday, Wednesday and Friday, 2:00 to 3:30 P.M., E.S.T.

The Tuesday and Friday special broadcasts are unmodulated c.w. except for 1-second standard-time intervals consisting of short pulses with 1000-cycle modulation. On Wednesday special broadcasts the carrier is modulated with 1000-cycle tone.

Accuracy of all frequencies, including audio modulating frequencies, is better than 1 part in 5,000,000.

External amplifiers, usually of the resistance-coupled type to provide high gain with wide frequency range and low distortion, are useful in most applications. Cathode-ray tubes, with sensitivity of perhaps 100 volts

per inch, are not suitable for use with potentials of less than several volts.

An example of a linear sweep circuit applied to a 2-inch cathode-ray tube is shown in Fig. 1733. The circuit elements in the center of the diagram comprise the sweep circuit. The 884 generates the saw-tooth sweep voltages, while the 6J7 acts as a current-limiting pentode to ensure linearity. A resistance synchronization control (R_{18}) is used.

High-gain vertical and horizontal amplifiers using 6J7's are provided, with inductance compensation in the plate circuits to extend the frequency range. Alternatively, inputs can be applied directly to the deflection plates to avoid any amplifier distortion if desired. In that case R_{19} and R_{20} serve as input level controls.

The remaining controls are: intensity control, R_2 ; focussing control, R_3 ; horizontal and vertical spot positioning controls, R_7 and R_8 ; sweep amplitude control, R_{14} ; sweep frequency vernier, R_{17} ; amplifier input level controls, R_{23} . Numerous switches control all circuits independently.

Constructional precautions include the placement of parts so the 902 is not affected by transformer fields. Amplifier input and output leads should be direct and placed well clear of other components to avoid frequency distortion and unwanted pick-up.

Properly built and used, a versatile oscilloscope such as this makes an instrument capable of handling many measurement and testing problems.

Emergency and Portable

Emergency, Portable and Rural Applications—Power and Supply Systems—Transmitting and Receiving Apparatus

EMERGENCY self-powered equipment is no longer a nice toy to play with when regular amateur activities pall; it has become the moral obligation of every amateur to be prepared in case of any communications emergency. Large-scale disasters during the past few years have demonstrated the tremendous value of amateur emergency stations in relaying relief messages when all other communication channels are closed. Aside from the all-important emergency phase, the use of portable equipment has lately been extended through organized activity in the annual "Field Days," and the problem of providing equipment suitable for use in rural districts, where commercial power is not available, has always been with us. Recent developments have furnished approaches to the solutions of some of the problems, and it is the purpose of this chapter to analyze and summarize the general considerations involved in the self-powered field, and to offer certain suggestions.

The most vital need for self-powered equipment occurs in connection with emergency activity, and the basic design of all such equipment should be predicated on emergency use. Every amateur, no matter where he may be located, can reasonably expect that sometime he may be called upon to perform emergency communications duty, and it is his responsibility to the public welfare, to himself, and to amateur radio as a whole to see that he is in some measure prepared.

It is not to be expected that every amateur will prepare himself for an emergency by having available a complete and separate self-powered station, although a large number of individuals and club groups do so. There is, however, no reason why every amateur cannot prepare his station for an emergency by having an emergency power supply ready and a quick means for utilizing all or part of his regular station equipment as an emergency-powered station. The emergency power supply can be anything from a small vibrator supply and/or batteries to a large gasoline-driven generator. It is the purpose of this chapter to present data on available types of self-powered supplies and to show how regular station equipment can be prepared for emergency applications.

If it is considered desirable to build separate portable/emergency equipment, the small re-

ceivers and transmitters described in Chapters Eight and Ten are recommended.

Choice of Power Supply

There is a comparatively wide variety of self-generating power sources from which to choose. An analysis of the numerous available types should disclose which is the most suitable in the light of specific requirements, based on the criteria of utility, efficiency, performance and cost.

Dry batteries: Dry-cell batteries are the standard primary electrical energy source. They are ideal for receiver and low-power transmitter supplies because they provide steady, pure direct current with almost zero regulation. Their disadvantages are weight, high cost and limited current capability. In addition, they will lose their power even when not in use if allowed to stand for periods of a year or more. This makes them uneconomical if not used more or less continuously.

Table 1 shows the life to be expected from representative types of batteries under various current drains, based on intermittent service simulating typical operation. Continuous service life will be somewhat greater at very low current drains and from one-half to two-thirds the intermittent life at the higher current values.

The life figures given in the table are based on an end-point of 34 volts. This is considered to be the normal limit in average equipment. With suitable design of the apparatus to enable it to operate satisfactorily on about half voltage, the end-point can be extended to 24 volts, adding approximately 50% to the life of the battery in average use.

The secret of long battery life at normal current drains lies in intermittent operation. The duration of "on" periods should be reduced to a minimum. The more frequent the rests given a dry-cell battery, the longer it will last. As an example, one standard type will last 50% longer if it is operated for intervals of one minute with five minutes' rest in 24-hour intermittent operation than if it is operated continuously for four hours per day, although the actual wattage consumption in the 24-hour period is the same.

Storage batteries: The most universally acceptable self-contained power source is the storage battery. It has high initial capacity and

The Radio Amateur's Handbook

can be recharged, so that its effective life is practically indefinite. It can be used to provide filament or heater power directly, and plate power through associated devices such as vibrator-transformers, dynamotors and generators, and a.c. converters. For emergency work a storage battery is a particularly successful power source since practically no matter what the circumstances such batteries are available. In a serious emergency it would be possible to obtain 6-volt storage batteries as long as there were automobiles to borrow them from and, for this reason, the 6-volt storage battery makes an excellent unit around which to design the low-powered p/e station.

For maximum efficiency and usefulness the power drain on the storage battery should be limited to 15 or 20 amperes from the ordinary 100- or 120-ampere-hour 6-volt battery. This should provide a carrier power when transmitting of 20 to 30 watts, which is usually adequate. In connecting the battery, heavy leads

of the automotive cable type should be used, to minimize the voltage drop; ordinary car-receiver leads are definitely not satisfactory. Similarly, heavy-duty low-resistance switches are required.

Vibrator-Transformers: The vibrator-transformer consists of a specially-designed transformer combined with a vibrating interrupter. When the unit is connected to a storage battery the circuit is made and broken rapidly by the vibrator contacts and the pulsating d.c. which flows in the primary of the transformer causes an alternating voltage to be developed in the secondary. This high-voltage a.c. is in turn rectified, either by a vacuum-tube rectifier or by an additional synchronized pair of vibrator contacts, and filtered, providing outputs as high as 400 volts at 200 ma. Tube rectifiers are ordinarily used only when the negative side of the circuit cannot be grounded, a requirement with the self-rectifying type. The high-voltage filter circuit is usually identical with that of an

TABLE I—BATTERY SERVICE HOURS

Estimated to 34-volt end point per nominal 45-volt section
Based on intermittent use of 3 to 4 hours daily
(For batteries manufactured in U. S. A. only)

Manufacturer's Type No.	Weight		Current Drain in Ma.											
	Lb.	Oz.	5	10	15	20	25	30	40	50	60	75	100	150
Eveready														
386	14	—	2000	1100	690	510	400	320	200	170	130	100	50	30
486	13	5	1700	880	550	395	300	240	165	125	100	70	45	20
586	12	2	1400	800	530	380	260	185	130	85	60	40	30	14
485	9	3	1000	525	375	250	200	135	100	60	40	20	15	7.5
585	8	13	900	450	290	210	130	100	60	45	25	20	11	5
762	3	3	320	140	81	54	37	27	—	—	—	—	—	—
482	2	—	320	140	81	54	37	27	—	—	—	—	—	—
738	1	2	160	70	30	20	10	7	—	—	—	—	—	—
733	—	10	50	20	11	7	5.2	—	—	—	—	—	—	—
455 ¹	—	8.6	70	20	11	7	5.2	—	—	—	—	—	—	—

¹ Same life figures apply to 467, 67½-volt, 10.5 oz.

Estimated to 1-volt end-point per 1.5-volt unit
Based on intermittent use of 3 to 4 hours daily
(For batteries manufactured in U. S. A. only)

Manufacturer's Type No.	Weight		Voltage	Current Drain in Ma.										
	Lbs.	Oz.		50	60	120	150	175	180	200	240	250	300	350
Eveready														
A-1300	8	4	1.25				2000	1715	1500	1333	1250	1200	1000	854
740	6	12	1.5				1400	1200		1050			775	625
741 ¹	2	14	1.5		1100	750				375	300	275	215	175
743	2	1	1.5		750	325				245		180	135	110
7111	2	2	1.5		700	320			200		120		90	
742	1	6	1.5		500	325			155	135	100	95	85	50
A-2300	15	8	2.5				2000	1715	1500	1333	1250	1200	1000	854
723	1	—	3.0		240	100			70		40		30	
746	1	3	4.5	200										
718 ²	3		6.0	375										

¹ Same life figures apply to 745, wt. 3 lbs.

² Same life figures apply to 747, wt. 3 lbs.

Emergency and Portable

TABLE II—VIBRATOR SUPPLIES

Manufacturer's Type No.				Output		Rectifier	Output Filter
Am. Television and Radio Co.	Electronic Labs	Mallory	Radiart	Volts	Ma.		
		VP-551 ¹		125-150-175-200	100 max.	Syn.	None
			4204 ²	100-150-250	35-40-60	Syn.	None
	605			150-200-250-275	35-40-50-65	Syn.	None
	604 ³	VP-552 ⁴	4203 ⁵	225-250-275-300	50-65-80-100	Syn.	None
	251 ⁶			300	100	Tube	Yes
		VP-555		300	200	Tube	Yes
VPM-6 ⁷	311 ⁸			250-275-300-325	50-75-100-125	Tube	Yes
		VP-557		400	150	Tube	Input condenser only
	606 ⁹			325-350-375-400 and 110 a.c. 60 cycle	125-150-175-200 20 watts	Tube	8 μ f.

All inputs 6 volts d.c. unless otherwise noted.

¹ VP-553 same with tube rectifier.

² 4204F same with filter.

³ 601 same with tube rectifier; 602 same except 12 v. d.c. input and tube rectifier; 603 same except 32 v. d.c. input and tube rectifier.

⁴ VP-554 same with tube rectifier; VP-G556 same except 12 v. d.c. input; VP-F558 same except 32 v. d.c. input.

⁷ Also available without filter.

⁸ 511 same except 12 v. d.c. input.

⁹ Input 6 v. d.c. or 110 v. a.c.; 607 same except 12 v. d.c. or 110 v. a.c. input; 608 same except 32 v. d.c. or 110 v. a.c. input; 609 same except 110 v. d.c. or 110 v. a.c. input.

TABLE III—DYNAMOTORS

Manufacturer's Type No.			Input		Output		Weight
Center	Eicor	Pioneer	Volts	Amps.	Volts	Ma.	Lbs.
135A			6	1.8	135	30	6½
180A			6	2.2	180	30	6½
240A			6	3.3	200	40	6½
210A			6	6.3	200	100	6½
220A			6	13	200	200	6½
250A	102 ¹	E1W272 ²	6	5	250	50	6½
251A		E1W339 ³	6	9	250	100	6½
277A			6	6	275	75	6½
301A	106 ⁴	E2W351 ⁵	6	9.7	300	100	6½
315A	158 ⁶	E2W243 ⁷	6	15	300	150	7½
320A		RAOW158 ⁷	6	19	300	200	9½
351A			6	10	350	100	6½
355A	108	E2W256 ⁸	6	15	350	150	7½
352A			6	22	350	200	9½
401A			6	13	400	100	7½
		E2W438	6	14.2	400	125	9¼
415A	109 ⁹		6	20	400	150	7½
420A			6	25	400	200	9½
425A		RA1W201 ⁹	6	30	400	225	9½
450A	110 ¹⁰		6	33	400	250	9½
		E3W413	6	15	500	100	11
515A	111 ¹¹		6	24	500	150	9½
520AR		RA1W189 ¹²	6	33	500	200	—

¹ Input current 4.6 amp., wt. 4½ lbs.

² Wt. 7½ lbs.

³ Input current 7.5 amp., wt. 7½ lbs.

⁴ Wt. 5 lbs.

⁵ Wt. 9¼ lbs.

⁶ Input current 14 amp., wt. 5¾ lbs.

⁷ Wt. 16 lbs., input current 18 amp.

⁸ Input current 17 amp.

⁹ Wt. 17½ lbs., input current 25 amp.

¹⁰ Input current 27.5 amp., wt. 7½ lbs.

¹¹ Input current 21.5 amp., wt. 7½ lbs.

¹² Input current 27 amp., wt. 17½ lbs.

The Radio Amateur's Handbook

equivalent power source operating from the a.c. line. Noise suppression equipment, serving to minimize r.f. disturbances, is usually incorporated in the manufactured unit.

Although vibrator-transformers are ordinarily used with 6-volt tubes, their use with 2-volt tubes is quite possible provided additional filament filtration is incorporated. This filter can consist of a small low-resistance iron-core choke, or the voice-coil winding of a speaker transformer. The field coil of a speaker designed to operate on 4 volts at the total filament current of the receiver may be used. The filaments are then connected in parallel, as usual, and placed in series with this winding across the 6-volt battery. On both 6- and 2-volt receivers "hash" can be reduced by heavily by-passing the battery at the vibrator supply terminals, using 0.25 to 1 μ f. or more. Noise will be minimized if a single ground, consisting of a short, heavy copper strap, is used.

Table II shows some of the available vibrator packs that can be used for the emergency or portable power supply. Some of the commercial units include a hum filter and some do not, but the design of this filter is, for the most part, conventional. The vibrator supplies used with automobile receivers are satisfactory for receiver application but usually are not desirable for use with a transmitter except where the power requirements are slight. The efficiency of vibrator packs is normally in excess of 60%.

Dynamotors and Genemotors: A dynamotor is a double-armature high-voltage generator, the additional winding operating as a driving motor. It is usually operated from a 6-, 12- or 32-volt battery, and may deliver voltages from

300 to 1000 or more. Dynamotors have been widely used in military work and many of those in amateur use derive from such origins.

The genemotor is a refinement of the dynamotor designed especially for automobile receiver, sound truck and similar applications. It has found wide acceptance among amateurs as a source of transmitting power, having good regulation and efficiency combined with economy of operation. It is also used in connection with portable receiver installations, although a rather high inherent noise level limits this application in sensitive amateur high-frequency receivers.

Genemotors are made to fill almost every need. Their cost, at amateur net prices, runs from about eight to twenty-four dollars. Standard models range from 135 volts at 30 ma. to 300 volts at 200 ma. or 500 volts at 200 ma. as can be seen in Table III. Parallel and series operation of identical units to provide higher capacity is entirely practical. The normal efficiency averages around 40%, increasing to better than 50% in the higher-power units. The regulation is comparable to well-designed a.c. supplies; it is largely a result of external IR drops.

Successful operation of dynamotors and genemotors implies heavy, direct leads, mechanical isolation to reduce vibration, and thorough r.f. and ripple filtration (the purchase of manufactured filter units is recommended). The shafts and bearings should be thoroughly "run in" before regular operation is attempted, and the tension of the bearings should be checked occasionally.

A.c.-d.c. converters: In some cases it may be

TABLE IV—GASOLINE ENGINE DRIVEN GENERATORS, AIR-COOLED

Manufacturer					Output		Weight	Starter
Ecor	Janette	Kato	Onan	Pioneer	Volts	Watts	Lbs.	
3AP6 ¹		JR-35 ² JRA-3 ²		BD-6 ¹	110 a.c. or 6 d.c.	300 200	100	Push-button
					110 a.c.	300	65	Push-button
					110 a.c.	350	65	Rope crank
		19A			110 a.c. or 6 d.c.	350 200	95	Push-button
					115 a.c.	350	91	Manual
					110 a.c.	400	—	Rope crank
ALBCA ¹		5L ³			110 a.c.	500	135	Manual
					110 a.c. or 6 d.c.	500 200	105	Push-button
		JR-55 ²			110 a.c.	550	90	Rope crank
		14A ³			110 a.c.	600	135	Push-button
6AP1	ALJKA ¹			BA-60 ¹	110 a.c.	750	195	Manual
10AP1				110 a.c.	1000	170	Push-button	
ALDEA ¹				BA-100 ¹	120 a.c.	1250	425	Manual
					110 a.c.	1500	275	Push-button

¹ Also available in remote-control models.

² Intermittent-duty model.

³ Weight, 165 lbs.

⁴ 115-volt output.

⁵ 115-volt output, weight, 200 lbs.

Emergency and Portable

desirable to utilize existing equipment built for 115-volt a.c. operation in portable applications. To operate such equipment with any of the power sources outlined in the foregoing would require a considerable amount of rebuilding. This can be obviated by using a rotary converter capable of changing the d.c. from 6-, 12- or 32-volt batteries or 110 d.c. lines to 110-volt 60-cycle a.c. Such converter units are available from several manufacturers, with output ratings from 40 to 300 watts. Their cost runs from fifteen to fifty dollars at amateur prices.

The conversion efficiency of these units averages about 50%. In appearance and operation they are similar to genemotors of equivalent ratings, while the prices are approximately the same. The overall efficiency of the converter system will be lower because of the losses in the a.c. rectifier-filter circuits and the necessity for converting heater as well as plate power.

Generators: The plate supply systems outlined in the foregoing are, with the exception of the dry-cell batteries, designed to utilize the electrical energy stored in a storage battery. The problem then arises of securing the energy to be stored in the battery. If access to a.c.-operated chargers is not possible at times between actual use, some form of self-powered charging system is essential.

This need is ordinarily best met by a gasoline- or wind-driven generator. Water-power generators have been used, but their dependence on special circumstances is obvious, and they are not available in small sizes.

The windcharger consists of a small generator driven by a suitable impeller, mounted to take advantage of the free energy offered by the wind. The standard type costing in the

neighborhood of twenty dollars will supply up to 16 amperes to a 6-volt battery. It will ordinarily keep fully charged a battery used to power a typical receiver and small transmitter operated from vibrator or genemotor supply in intermittent operation. (*Bib. 1*).

Gasoline-driven generators are also available for use in charging 6-volt or larger batteries. These ordinarily are rated at 150 or 200 watts and cost in the neighborhood of forty dollars. A $\frac{1}{2}$ - or $\frac{3}{4}$ -h.p. single-cylinder four-cycle engine is used, which will operate for twelve or fifteen hours on a gallon of gasoline.

In higher-powered installations the use of intermediate storage batteries may be dispensed with, and a gasoline-driven generator supplying 110-volt a.c. directly may be employed. Such generators are ordinarily rated at a minimum of 250 or 300 watts, and cost fifty or sixty dollars. They are available up to two kilowatts, or big enough to handle the highest-power amateur rig, at a cost of between three and four hundred dollars. Most are arranged to charge automatically an auxiliary 6- or 12-volt battery used in starting. Fitted with self-starters and adequate mufflers and filters, they represent a high order of performance and efficiency.

A variant on the generator idea is the use of fan-belt drive. The disadvantage of requiring that the automobile must be running throughout the operating period has not led to general popularity of this idea amongst amateurs, although in San Francisco and Oakland an amateur emergency unit relies on it heavily. Such generators are similar in construction and capacity to the small gas-driven units.

The home construction of generators of all the above types has been successfully at-

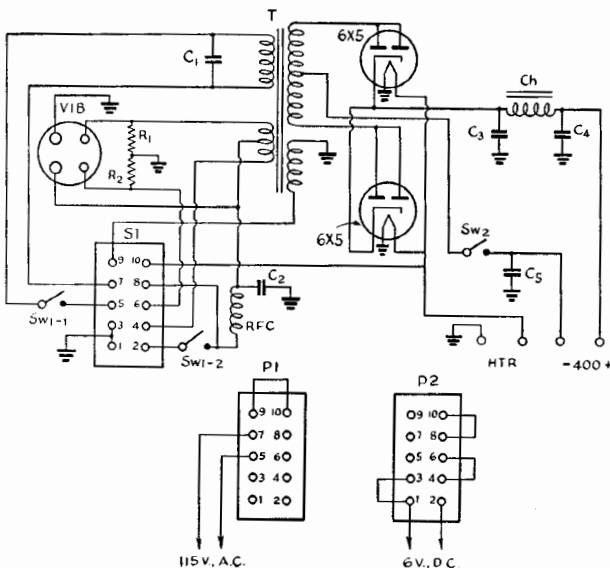

Fig. 1801 — Combination 6- and 115-volt power supply.

- Ch — 120-ma. 4-henry filter choke (Thordarson T-49C91).
- C₁ — 0.06- μ fd. paper, 400-volt.
- C₂ — 0.5- μ fd. paper 200-volt.
- C₃ — 8- μ fd. electrolytic, 600-volt.
- C₄ — 12- μ fd. electrolytic, 450-volt.
- C₅ — 10- μ fd. electrolytic, 25-volt.
- R₁, R₂ — 100 ohms, $\frac{1}{2}$ -watt.
- T — 375-volt 135-ma. power transformer with 115-volt and 6-volt primaries (Thordarson T-14R40).
- SW₁ — D.p.s.t. heavy duty toggle switch.
- SW₂ — S.p.s.t. toggle switch.
- S₁ — 10-contact male socket (Jones P-310-AB).
- P₁, P₂ — 10-contact male plugs (Jones S-310-FHT).
- RFC — 40 turns No. 14 enamelled wire, wound in two layers, $\frac{5}{8}$ " i.d.
- Vib. — Mallory 825 or 294. 825 will handle more current.

The Radio Amateur's Handbook

tempted by amateurs at times, although the possession of a considerable knowledge of electric motor design is essential. One especially useful possibility is the re-winding of old automobile charging generators, several hundred watts capacity being obtainable from the largest sizes. Those originally used on the old 4-cylinder Dodge cars have been successfully adapted by amateurs. Trade schools will often have their students rewind these generators for only the cost of the material, and this possibility is worth investigating. (*Bib. 2*).

An example of portable/emergency power supply design capable of operation from either 115-volt a.c. or vibrator-interrupted 6-volt storage battery d.c. is shown in Figs. 1801 and 1802. It is built around a dual-primary transformer. Two power cables are provided, one ending in a standard a.c. male plug and the other in battery clips. Miniature multiple plugs connect these cables to the appropriate primary, open or close the vibrator circuit as required, and connect the heater circuit either to a 6.3-volt winding or to the storage battery.

A simple hash filter in the form of a fixed wound of ordinary antenna wire and a fixed condenser minimizes vibrator interference sufficiently to make break-in operation satisfactory.

The circuit shows the negative high-voltage terminal ungrounded, permitting inclusion of a bias or microphone voltage dropping resistor if desired.

Portable Equipment — The Receiver

The weakest link in the portable or emergency communications chain usually is the receiver. An inadequate receiver, with poor selectivity, low sensitivity and insufficient stability, can ruin a QSO even under favorable conditions. When it is remembered that conditions in portable or emergency operation are often more severe than those at home, with poor antenna facilities, high noise levels, severe interference, etc., the fallacy of attempting to use an inferior portable receiver is apparent.

The best procedure of all is to use the home station receiver for portable work. Headphones should be used and the output tube removed, but this is no hardship. Headphones are far more satisfactory in such applications than the speaker in any event. This procedure not only ensures the availability of the high-performance receiver so vitally necessary, but the practice that has been obtained by using the receiver at home is invaluable in the specialized operating techniques of portable or emergency work. It takes as much experience to learn to run a receiver properly as it does to drive a car, and the middle of a crisis is no time to gain that experience. Even on lowered plate voltage the home superhet will be better than a makeshift.

If a special portable/emergency receiver is to

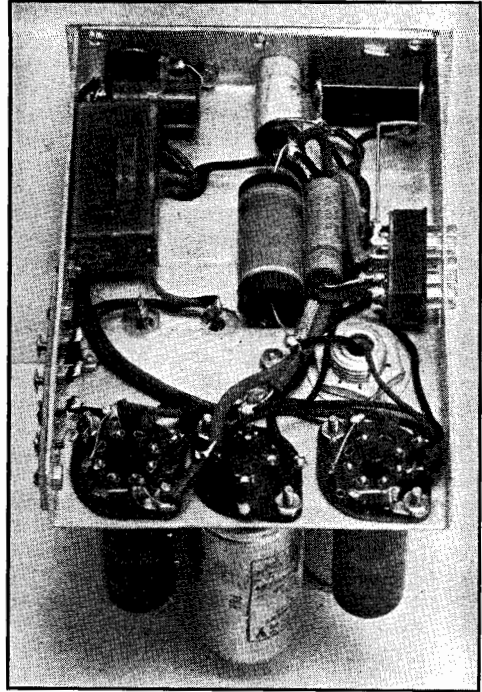

Fig. 1802 — The dual-primary power supply viewed from the bottom. Between the two rectifier tubes is mounted the plug-in vibrator. The primary r.f. choke can be seen between the two switches.

be built, it should be a superheterodyne. With present-day tubes and components, it is possible to build a simple superheterodyne as cheaply as a t.r.f. receiver, and there is no comparison between the two in performance. The average communications superheterodyne can be operated with storage battery heater supply and dry-cell or vibrator-pack "B" supply. With the audio power tubes removed from the receiver, the power requirements are not too great. Some of the receivers on the amateur market have provision at the rear of the set for plugging-in a d.c. supply, and those that don't can be easily modified by drilling a socket hole at the rear of the receiver and wiring it into the set. When regular a.c. operation is used, a shorting plug in the socket completes the circuit. A little study of the wiring diagram of the receiver will show how it can be adapted to battery or other self-powered operation.

Portable Equipment — The Transmitter

Owing to the difficulty in securing power for emergency, portable and rural transmitters, their design will depend almost entirely upon the power supply available. Considering possible defects in hastily-improvised radiation systems, etc., it seems unwise to use less than 10 watts input to a power amplifier or 15 watts

Emergency and Portable

to an oscillator. However, powers greater than two or three times these values are not usually necessary, so selection of the power supply will depend almost entirely upon the pocketbook and other resources. The 300-volt, 100-ma. vibrator-transformers and genemotors represent a nice compromise unless it is possible to step into the 200- or 300-watt gasoline-driven generator class. (*Bib. 3*).

Perhaps the best plan in providing for an emergency and portable transmitter is to utilize the basic exciter unit in the regular station. This not only ensures the availability of a reliable, efficient unit at all times but means a saving in parts and equipment. It represents no hardship to the permanent station to construct the exciter so it is compact, readily removable, and, above all, solidly and dependably assembled. If your present exciter is not adaptable to this use, plan the new one so it will be. Of course, provision for 6-volt tubes throughout is essential, with the heater circuit so arranged that it can be connected to a storage battery without change. A suitable plate supply using a vibrator or genemotor or similar system should be available separately, arranged for ready connection. The best method is to have a socket and plug connector assembly, with one plug built into the transmitter and another, wired identically, connected permanently to the emergency supply.

The complete portable/emergency station will be capable of operation on both c.w. and 'phone. Both have their special advantages, especially in emergency work. When power is limited and conditions bad, the greater reliable range and higher communications efficiency of c.w. often make its use preferable to voice. Where instructions and general traffic must be handled rapidly and in quantity, on the other hand, the greater speed of voice over code makes modulated transmission desirable.

Antenna Systems

It is difficult to specify standard antenna systems for emergency or portable applications, because in all cases the location is the determining factor. As with most things, the simplest antenna is ordinarily the best.

One of the simplest systems is the end-fed antenna. A single half-wave on the lowest frequency to be used will radiate plenty of energy, providing a good part of its length is well above ground. If it is cut reasonably close to resonance efficient coupling is assured by connecting directly to the plate (through a variable condenser) or to a supplementary link-coupled tuned circuit.

If a transmission line is essential, it should be as well-constructed as possible. The single-wire-fed type is ideal if the feed line can be brought off the antenna at right angles. The feeder should be tapped on the plate coil (through a 0.002- μ f. fixed condenser) at the point where the desired loading occurs, making sure that the tank circuit is tuned to resonance. The tables shown in Chapter Twenty-Two for this type of antenna should be followed closely.

A low-impedance two-wire line is excellent if the antenna is to be an integral part of the portable station, since if it is too long it can be coiled-up out of the way. Rubber-covered lamp cord will make a fair feed line, the slight mismatch accounting for only a small loss of power. For the meticulous, one of the special 72-ohm lines can be used.

The familiar tuned transmission line, of either the Zepp or center-fed types, is next in preference. It is dependable in performance but somewhat more complicated to erect. The antenna coupling system should be extremely flexible with this type, with tapped coils and choice of series and parallel connections to accommodate any feeder length. The feeders should be kept short and direct.

Emergency antennas may be erected with insulation of dry hard wood, glass towel bars, porcelain ware, etc., with wire salvaged from broken communications (not power!) lines or similar sources. If it is impossible to erect resonant lengths of wire, impedance-matching systems such as that shown in Chapter Twenty-Two can be used. Tuning can be accomplished by plate milliammeter, neon bulb, or a flashlight bulb in series with the antenna.

Probably the most straightforward preparation for different conditions is to include several lengths of rope with the portable antenna, so that a line may be thrown into a tree or dropped out of a window. Portable masts can be built but involve rather serious construction difficulties.

Regulations

The F.C.C. regulations covering amateur portable and emergency work should be studied thoroughly by every amateur. See Chapter Thirty-Two.

Bibliography

¹ "Getting Power from the Winds," *QST*, March, 1934, p. 28. Lynch, "A More Efficient Impeller for Wind-Driven Generators," *QST*, April, 1935, p. 48.

² Burchfield, "Rewinding an Auto Generator for Portable-Emergency 110-Volt A.C. Supply," *QST*, November, 1937, p. 26.

³ "Portable-Emergency Transmitters," *QST*, August, 1939, p. 22. Austin, "A Different Portable-Emergency Transmitter," *QST*, July, 1940.

Assembling The Amateur Station

Location and Arrangement of Station—Control Systems— Receiver Protection—Lead-in Arrangement—Break-in and Remote Control—Safety Devices and Precautions

THE element of danger to the operator and others of the household from high voltages, as well as convenience, should be considered seriously in planning the arrangement of station equipment.

● LOCATION OF STATION

Where space is at a premium, the transmitter may be built into a desk or radio console. If conveniently located, a spare closet makes a very good spot for the transmitter and may be arranged as shown in Fig. 1901. If necessary, the transmitter may be located in the basement or attic, in a closet or even in a weather-proof box outside the house and operated by remote control. Apartment-house dwellers sometimes build up a compact arrangement on wheels which may be stored under the kitchen range or sink and brought out to the operating position whenever desired.

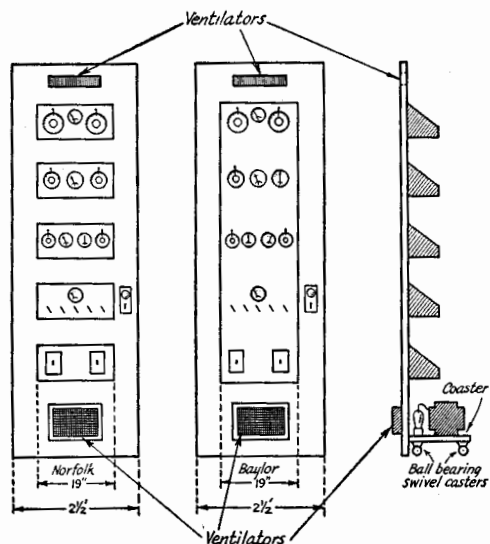

Fig. 1901—Transmitter mounted on clothes-closet door. Standard rack construction may be followed. Weight of heavy units is taken up by rollers at bottom. The door may be replaced at little expense.

Arrangement of Equipment

If the transmitter is to be built into a floor rack (construction described in Chapter 13) or a frame, an operating table with a top of 24" by 36" has sufficient space for a receiver of good size, key or microphone, control switches and room for writing. A drawer will take care of plug-in coils, small tools and writing materials. An operating table of somewhat greater length will afford space for additional apparatus such as the monitor or small transmitter. A shelf underneath will provide space for an enclosed receiver power supply, emergency apparatus, etc.

The transmitter should be located near a window where the antenna or transmission line may be brought in most conveniently and also near the operating position where frequency changes which may be made by adjustment of tuning controls on the front of the panel may be made without leaving the operating position. One good arrangement is shown in Fig. 1902. The transmitter rack is within easy reach of the operator. Since the lowest controls of the average rack transmitter come above the table level, it might be placed against the end of the operating table with controls facing either the operator or the center of the room. Space between the wall and transmitter should be left to permit passage to the side and rear for coil changing.

If the transmitter is built up in breadboard style, it may be placed upon a second table in the position in which the rack is shown. Sometimes breadboard units are assembled, one above the other, on a series of shelves emulating rack construction. Power-supply equipment may be assembled upon a heavy board and placed under the transmitter table. A suitable screen should be fastened to the legs of the table to prevent approach to the high-voltage apparatus, and high-voltage wiring should be brought up at the rear of the table to the transmitter. While the receiver power supply may be placed upon a shelf under the operating table, under no circumstances should the transmitter power supply be placed there

Assembling The Amateur Station

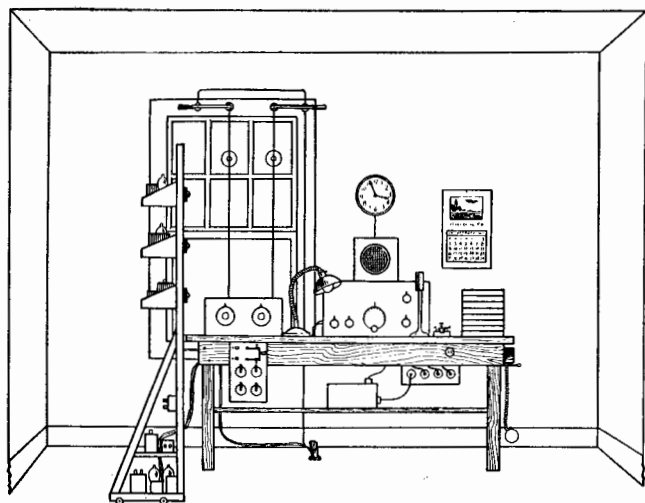

Fig. 1902 — A convenient arrangement for station. The rack transmitter panel is within easy reach of the operator. On the table are the antenna tuner, lamp, receiver and loudspeaker, microphone, key and stationery file. The entrance switch is fastened to the right-hand end of the table. Transmitter controls are mounted on a board fastened to the table at the left of the operator with foot-operated control switch underneath the table. Receiver power supply is on shelf underneath. Service outlets are mounted on board fastened to rear of table. Lightning switches at top of window with ground wire running down right side of window.

unless completely enclosed. In cases where the power-supply equipment is too bulky to be placed in the operating room, it is sometimes placed in the basement and wired up to the operating room. If this is done, the wiring should be suitably insulated and the apparatus fenced off to prevent anyone coming in contact with it.

Control Circuits

Proper arrangement of controls is fully as important as convenient arrangement of apparatus. If the transmitter is to be of fairly high power, it is desirable to provide a special service line directly from the meter board to the operating room. This line should be run in conduit or BX cable with conductors of ample size to carry the load without undue voltage drop. The line should be terminated with an enclosed entrance switch properly fused.

Fig. 1903 shows the wiring diagram of a simple control system. It will be noticed that, because the

control switches are connected in series, none of the high-voltage supplies may be turned on until the filament switch has been closed and that the high-power plate supply cannot be turned on until the low-power plate supply switch has been closed, and also, that the modulator power cannot be applied until the final-amplifier plate-voltage has been applied. SW_5 places a 100- to 300-watt lamp (L_p) in series with the primary winding of the high-voltage plate transformer for use during the process of preliminary tuning and for local c.w. work. The final amplifier should be tuned to resonance first at low voltage and then SW_5 is closed, short-circuiting the lamp. Experience will determine what the low-voltage plate-current reading should be to have it increase to full-power value when SW_5 is closed so that the proper antenna coupling and tuning adjustments may be

made at low voltage.

Preferably, SW_3 should be of the push-button type which remains closed only so long as pressure is applied. A switch of this type provides one of the simplest and most effective means of protection against accidents from

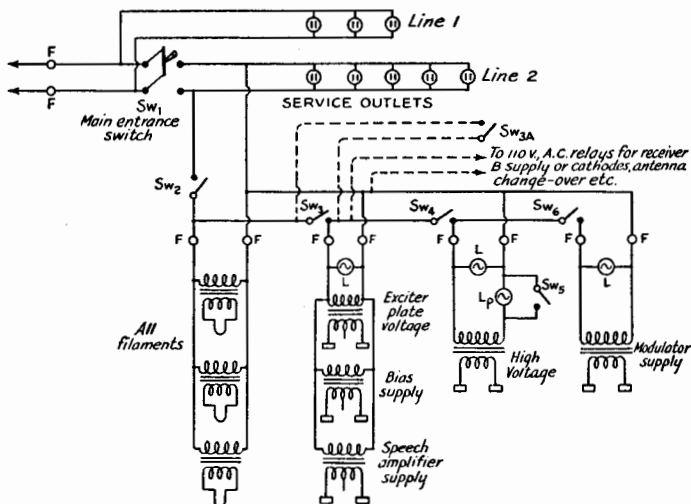

Fig. 1903 — Station control system. With all switches except SW_3 closed, SW_3 serves as the main control switch. SW_1 — Enclosed entrance switch. SW_2 — Filament switch. SW_3 — Low plate-voltage and main control switch. (See text.) SW_4 — High plate-voltage switch. SW_5 — Low-power and tune-up switch. (See text.) SW_6 — Modulator plate-voltage switch. F — Fuse. L — Warning light. L_p — Voltage-reducing lamp. (See text.)

The Radio Amateur's Handbook

high voltage. In the form which is usually considered most convenient, it consists of a switch which may be operated by pressure of the foot and is located underneath the operating table. When used in this manner, it means that the operator must be in the operating position, well removed from danger, before high voltage may be applied. If desired, SW_{3a} may be placed on the *front* of the transmitter panel so that it may

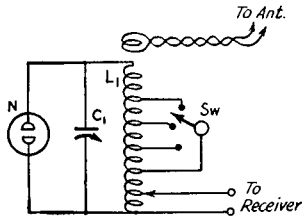

Fig. 1904 — Simple protective device for receiver. When the voltage induced across L_1 C_1 by transmitter becomes too great, the neon tube breaks down, short-circuiting the tuned circuit. L_1 and C_1 are any coil and condenser which will tune over the required range. Bare wire is suggested for L_1 so that adjustment of the taps will be simplified.

be used while tuning the transmitter. SW_{3a} should, of course, be of the push-button type also.

In more elaborate installations, and in remote control systems, similarly arranged switches control relays whose contacts serve to do the actual switching at the transmitter.

Two strings of utility outlets are connected, one on each side of the entrance switch, for operation of the receiver and such accessories as monitor, lights, electric clock, soldering iron, etc. Closing the entrance switch should close those circuits which place the station in readiness for operation. SW_2 and SW_4 are normally closed and SW_3 open. When SW_1 is closed upon entering the operating room, the transmitter filaments are turned on as well as the receiver which should be plugged into line No. 2. With SW_4 closed (also SW_5 and SW_6), SW_3 performs the job of turning all plate-supplies on and off during periods of transmission and reception. Continuously operating accessories, such as the clock, should be plugged into line No. 1 so that it will not be turned off when SW_1 is opened. Line No. 1 is also of use for supplying a soldering iron, light, etc., when it is desired to remove all voltage from the transmitter by opening SW_1 .

Receiver Protection

Unless certain precautions are taken, operation of a transmitter in close proximity may cause damage to the receiver. Low-power transmitters

seldom cause trouble unless both transmitter and receiver are unshielded and the output circuit of the transmitter is so close to the input of the receiver as to provide appreciable coupling between the two. Higher-power transmitters may induce voltages so great in the input circuits of the receiver that, even though the receiver plate supply is turned off during periods of transmission, grid current is sufficient to ruin the input tube and sometimes burn out the cathode resistance. Well shielded receivers are much less susceptible to damage and frequently are used with more or less success without protection of any form, although it may be necessary to replace the input tube at intervals. It is always advisable, however, to make some provision for protecting the receiver against possible damage.

Short-circuiting of receiver input terminals by means of a switch or a relay operated from the transmitter control switch is only partially effective, especially at the higher frequencies. A simple precaution, which is often found adequate, is to provide a switch which opens the cathode circuit of the input tube, preventing the flow of grid current, although a considerable d.c. potential may exist between heater and cathode.

Another simple arrangement, suggested by W3BES, involves the use of a neon tube to short-circuit a high-impedance antenna tuner. It is shown in Fig. 1904. Probably the most effective and logical scheme is one provided by W8JMI, shown in Fig. 1905, in which a separate rectifier with external pick-up is used to bias the first or first and second r.f. tubes of the receiver.

Bringing the Antenna or Transmission Line into the Station

In bringing the antenna or transmission line into the station, the line should first be anchored to the outside wall of the building, as shown in Fig. 1906, to remove strain from lead-in insulators. When permissible, holes cut

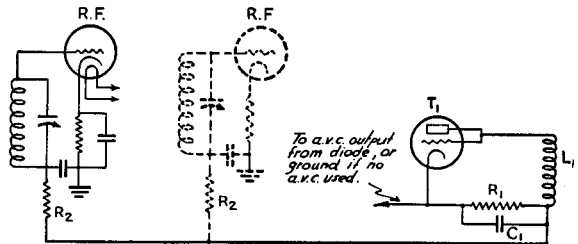

Fig. 1905 — Another protective device for receiver. L_1 is a pick-up coil coupled to the transmitter output tank circuit. Size of coil must be determined by experiment. C_1 — .002 μ fd. R_1 — 100,000 ohms suggested for first trial. Experiment with particular set-up will be necessary. R_2 — Decoupling resistors in receiver AVC system.

T_1 — Any tube with grid and plate tied together.

Assembling The Amateur Station

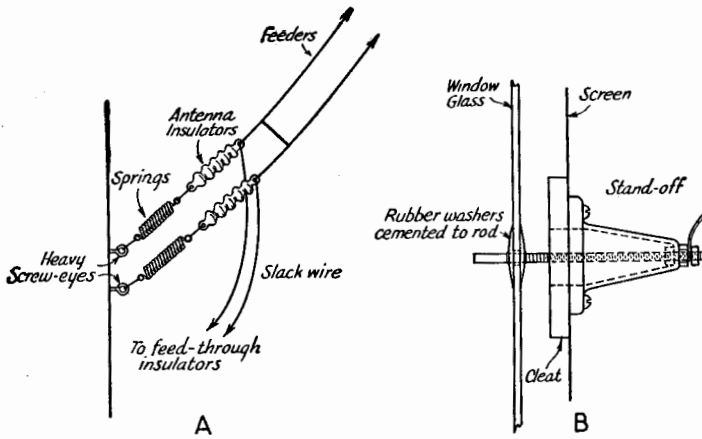

Fig. 1906 — Bringing the feeders in. A — Anchoring feeders to take strain from feed-through insulators or window glass. B — Going through a full-length screen. The cleat is fastened to frame of screen on inside of screen. Clearance holes are cut in the cleat and also in the screen. The rubber washers keep the weather out.

directly through the walls of the building and fitted with feed-through insulators of suitable size are undoubtedly the best means of feeding the antenna into the station, for the job can be done with little difficulty and can provide greater mechanical permanence than other schemes. It involves no interference to screening or storm windows. The holes should have plenty of air clearance about the conducting rod, especially when tuned lines, which develop high voltages, are employed. Probably the best place to go through the walls, from the standpoint of appearance, is the trimming board at the top or bottom of a window frame which provides flat surfaces for tightening lead-in insulators. Cement or rubber gaskets may be used to water-proof the exposed joints.

Where such a procedure is not permissible, the window itself usually offers the best opportunity. One satisfactory method is to drill holes in the glass near the top of the upper sash. If the glass which is to be drilled is replaced by plate glass, a stronger job will result. Plate glass may be obtained reasonably from automobile junk yards and may be drilled before placing in the frame. The glass itself provides the necessary insulation and the transmission line may be fastened to bolts fitting the holes. Rubber gaskets cut from inner tube will render the holes water-proof. The lower sash should be provided with stops at a suitable height to prevent damage when it is raised. If the window is fitted with a full-length screen, the

scheme shown in Fig. 1906-B may be used.

In a less permanent method, the window is raised from the bottom or lowered from the top to permit the insertion of a board three or four inches wide which carries the feed-through insulators. This arrangement may be made weather-proof by making an overlapping joint between the board and window sash, as shown in Fig. 1907, and covering the opening between upper and lower sashes with a sheet of soft rubber cut from an inner tube.

When the transmitter must be located at a considerable distance from the point at which the antenna transmission line enters the building, the most practical way of feeding the antenna is by means of a low-impedance transmission line which may be fastened along the picture moulding near the ceiling. If multi-band operation is desired, a separate antenna for each band will be required; otherwise, it will be necessary to place the antenna tuner at the point at which the feeders enter the building and couple the antenna tuner to the transmitter by means of a low-impedance line. This arrangement is very awkward to tune with the antenna and final-amplifier tank circuits separated so widely.

Antenna Switching

As pointed out in later chapters it is desirable, particularly in DX work, to use the same antenna for transmitting and receiving. This requires switching of antenna from transmitter to receiver. One of two general systems may be employed. In the first, the transmitter and receiver are each provided with an antenna tuner and the antenna transmission line is switched from one to the other. In the second system, one antenna tuner is provided for each antenna and the switch is in the low-impedance coupling line. Several arrangements are shown in Fig. 1908. The high voltages which develop on tuned lines require switches and wiring with good insulation. Frequently relays with low-capacity contacts are substituted for the

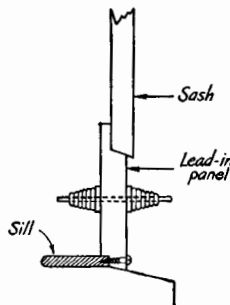

Fig. 1907 — Antenna lead-in panel. It may be placed over the top sash or under the lower sash of window. The overlapping joint makes it weather-proof. The single thick board may be replaced by two thinner boards fastened together.

The Radio Amateur's Handbook

hand-operated switches. Either way is satisfactory.

Remote Control

When it becomes necessary to locate the transmitter at some point remote from the operating position, it is usually more feasible to control the transmitter by means of relays rather than to attempt to carry power wiring between the transmitter and operating position. Not only must the wiring be more carefully executed, but considerable drop in voltage may develop unless wire of large size is used. Relays require little current and low-voltage types require wiring with a relatively small amount of insulation. Wiring for a large transmitter may be bonded into a small cable occupying but little space. A typical arrangement for remote control is shown in Fig. 1909. In 'phone installations, it is common practice to place the modulator and driver with the transmitter and speech amplifier at the operating position, coupling the two with a low-impedance line.

Where distance between control point and the transmitter makes it important, the number of control lines may be reduced by a scheme shown in Fig. 1910. Relays 1, 2 and 3 are adjusted to close at progressively increasing values of current. In operation, SW_1 is closed and, with R_1 and R_2 in series, the line current is sufficient to close only Relay No. 1 which will turn on filaments and bias supply. When SW_2 is closed, R_1 is cut out of the circuit and the line current increases to a value sufficient to close relay No. 2 which turns on the high voltage, but not No. 3. The key short-circuits R_2 and again the line current increases closing relay No. 3, the keying relay. The system requires rather careful adjustment and values will depend upon relay characteristics and line voltage. Those interested in a more extensive circuit for frequency changing, modulation checking as well as power control by means of a single pair of wires are referred to page 37 of *QST* for July 1938.

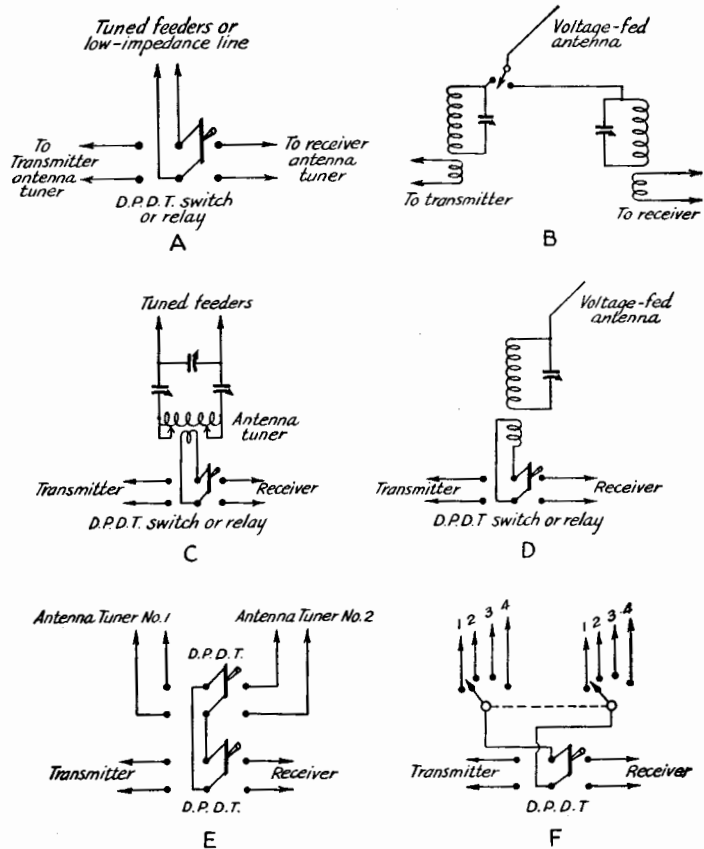

Fig. 1908 — Antenna switching systems. A — For tuned lines with separate antenna tuners or low impedance lines. B — For voltage-fed antenna. C — For tuned line with single tuner. D — For voltage-fed antenna with single tuner. E — For two tuned-line antennas with tuner for each antenna or for low-impedance lines. F — For several two-wire lines.

Break-in

The advantages of break-in operation are many and are described in Chapter 31. If the station is provided with a stable, shielded superheterodyne receiver, it may be necessary only to use a separate antenna for the receiver. This should be located as far as possible from the transmitting antenna and at right angles to it. Sometimes a short receiving antenna will reduce interference from the transmitter and yet permit reception from stations at quite some distance. Use of the external rectifier of Fig. 1905, described in connection with receiver protection, is recommended where break-in operation is desired. With unshielded or regenerative receivers, it may be necessary to provide a relay which opens the headphone circuit when the key is closed to prevent racket in the headphones which might paralyze the ear for the weaker break-in signal. In this case, an output transformer between receiver and

Assembling The Amateur Station

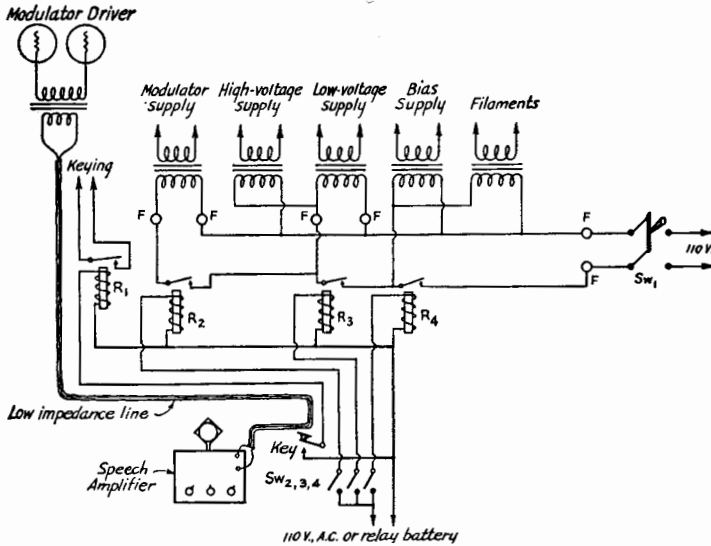

Fig. 1909 — Remote control system. This system is essentially the same as that shown in Fig. 1903 except that the switches control relays at the remote transmitter which do the switching. The speech amplifier and modulator driver are coupled with a low-impedance line.

headphones with the relay breaking the connection between headphones and transformer secondary winding is recommended. In extreme cases, an additional relay short-circuiting the receiver input may be required. All of these relays should be connected so as to operate with the key.

If the same antenna is used for receiving as well as transmitting, a change-over relay operating from the keying circuit must be added.

Unless the transmitter oscillator is very well shielded, it will be impossible to use break-in operation with a station on the frequency of the transmitter or frequencies immediately adjacent unless the oscillator is keyed. Most break-in systems employ keyed oscillators with the following amplifier stages provided with sufficient fixed bias to prevent plate-current flow with excitation removed.

'Phone Break-in — Push-to-Talk

Break-in operation with 'phone becomes

more complicated and less practicable because of the increased difficulty in distinguishing the wanted signal from others. A method of electronic control of the carrier is described in detail in *QST* for November 1936. The voice signal operates a relay which cuts the carrier off if there is a short pause in speech, the carrier resuming whenever speech is resumed.

A more commonly used system is the "push-to-talk" method. In this system, a convenient "push" switch, such as the foot-operated switch mentioned in connection with Fig. 1902, is used to cut the carrier, and also the oscillator, on and off. With this arrangement and the receiver precautions recommended for break-in operation, 'phone conversations may be speeded up and made more pleasurable.

Safety Precautions

The following excerpts from the A.R.R.L. Safety Code apply particularly to the arrangement and installation of station control equipment:

Master Switch — There should be one powerline switch, in a conspicuous and easily-accessible location on or near the transmitter, which controls all power to the transmitter.

H. V. Leads — High-voltage leads should be a good grade of high-tension wire insulated for at least two to three times the peak operating voltage.

Keys — The arm of the telegraph key should be grounded in every case. In keying circuits which do not permit a direct ground on the key, a suitably-insulated relay should always be used. Live parts of the key should be protected from accidental bodily contact by suitable covers or barriers.

Relays — Relays should be provided with covers, or installed in such fashion that accidental closing by mechanical means cannot occur.

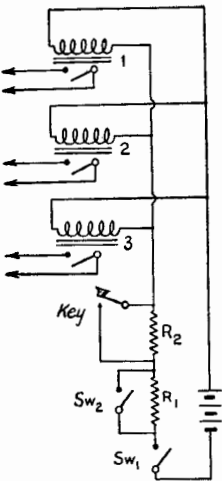

Fig. 1910 — The number of control wires may be reduced by this method for long remote lines. Relays are adjusted to close on different currents controlled by resistances.

The Radio Amateur's Handbook

Safety Devices

The series shorting plug scheme shown in Fig. 1911 is a very simple and effective method of cutting off the primary supply to the transmitter whenever work is to be done or adjustments to be made, providing one forms the habit of using it every time the transmitter is approached. The socket should be mounted in a convenient place on the operating table; when the plug is out, no power can get to the transmitter. If you carry the plug with you, you *know* the power is off and that no one can turn it on.

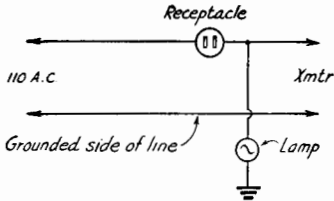

Fig. 1911 — Series-plug arrangement for cutting supply line to transmitter during adjustments. The lamp indicates when the series plug is in the ungrounded side of the line as it should be.

The signal light serves as a check on line "polarization" as well as a warning when the shorting plug is in place. If the lamp does not light when the shorting plug is in place, the line is polarized incorrectly and connections to the a.c. line should be reversed. The outlet for the shorting plug and the warning light may be obtained as a unit at most electrical supply houses.

A similar scheme applied as a door interlock in enclosed transmitter construction is shown in Fig. 1912. Here again, the plug and receptacle should be in the ungrounded side of the supply line.

A dependable signal-light system is shown in Fig. 1913. Since either bulb must be on at all

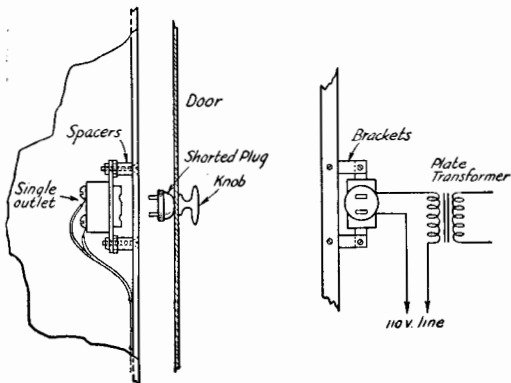

Fig. 1912 — Series-plug idea adapted as cabinet-door interlock. Plug should be in ungrounded side of line.

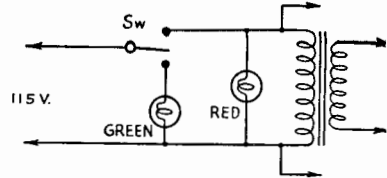

Fig. 1913 — Double signal-light system avoiding danger of lamp burn-out. Whenever both lights are out, they should be tested.

times, a burned-out lamp is indicated when no light at all shows.

Lightning Protection

An ungrounded radio antenna, particularly one large and well elevated, is a lightning hazard. When grounded, it provides a measure of protection. Therefore, grounding switches, such as are shown in Fig. 1902, or lightning arrestors should be provided. Examples of

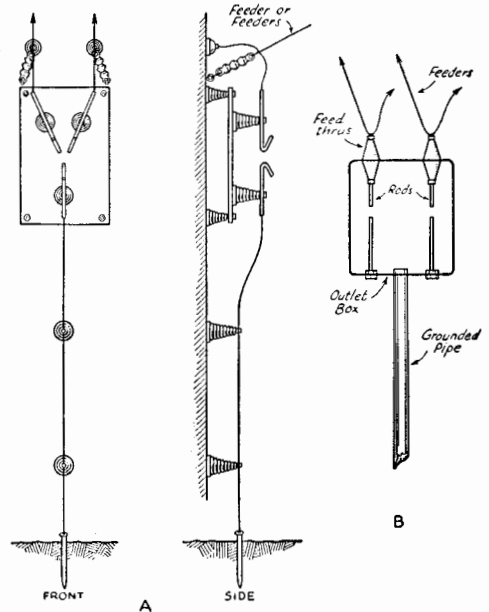

Fig. 1914 — Low-loss lightning arrestors for transmitter installations.

construction of low-loss arrestors are shown in Fig. 1914. At A, the arrestor electrodes are mounted by means of stand-off insulators on a fireproof asbestos board. At B, the electrodes are enclosed in a standard steel outlet box. In each case, the gaps should be made as small as possible without danger of break-down during transmitter operation. Lightning systems require the best ground connection obtainable.

Tube Characteristics and Miscellaneous Data

THIS chapter represents a compilation of miscellaneous data useful to the practising radio amateur. By far the larger part of it is devoted to data on hundreds of different types of transmitting and receiving vacuum tubes available from a number of manufacturers, including typical operating conditions and base connections. The remainder of the chapter contains reference information in both tabular and narrative forms, intended to illustrate and supplement the basic material throughout the remainder of this *Handbook*.

Inductance (*L*)

The formula for computing the inductance of air-core radio coils is:

$$L = \frac{0.2 A^2 N^2}{3A + 9B + 10C}$$

where: *L* is the inductance in microhenrys
A is the mean diameter of the coil in inches
B is the length of winding in inches
C is the radial depth of winding in inches
N is the number of turns.

The quantity *C* may be neglected if the coil is a single-layer solenoid, as is nearly always the case with coils for high frequencies.

For example, assume a coil having 35 turns of No. 30 d.s.c. wire on a receiving coil form having a diameter of 1.5 inches. Consulting the wire table, we find that 35 turns of No. 30 d.s.c. will occupy a length of one-half inch. Therefore,

$$\begin{aligned} A &= 1.5 \\ B &= .5 \\ N &= 35 \end{aligned}$$

and

$$L = \frac{0.2 \times (1.5)^2 \times (35)^2}{(3 \times 1.5) + (9 \times .5)}$$

or 61.25 microhenrys.

To calculate the number of turns of a single-layer coil for a required value of inductance:

$$N = \sqrt{\frac{3A + 9B}{0.2A^2} \times L}$$

More rapid and convenient calculations in designing coils can be made with the A.R.R.L. *Lightning Radio Calculator* (Type A). Stated generally, the self-inductance of a coil is inversely proportional to the reluctance of its magnetic circuit and is proportional to the square of the number of turns. If the magnetic circuit is a closed iron core, for instance, the inductance

value might be several thousand times what it would be for the same coil without the iron core, the reluctance being that much less than with an air-core. Also, doubling the number of turns would make the inductance 4 times as great.

Condenser Capacity (*C*)

The formula for the capacitance of a condenser is:

$$\begin{aligned} C &= \frac{kA(n-1)}{4\pi d \times 9 \times 10^5} \\ &= .0088 \frac{kA}{d} (n-1) 10^{-5} \mu\text{fd.} \end{aligned}$$

where: *A* = area of one side of one plate (sq. cm.)

n = total number of plates

d = separation of plates (cm.)

k = specific inductive capacity or dielectric constant of the dielectric.

When *A* is the area of one side of one plate in square inches and *d* is the separation of the plate in inches,

$$C = .02235 \frac{kA}{d} (n-1) 10^{-5} \mu\text{fd.}$$

The dielectric constant determines the quantity of charge which a given separation and area of plates will accumulate for a given applied voltage. The "inductivity" of the dielectric varies as in the table. "*k*" is the ratio of the capacitance of a condenser with a given dielectric to its capacitance with air dielectric.

Table of Dielectric Constants

Dielectric	"k"	Puncture voltage	
		Kilovolts per cm.	Kilovolts per inch
Air (normal pressure)	1.00	7.8-9.0	19.8-23.8
Flint Glass	6 to 10	900	2280
Mica	4.6 to 8	1500	3810
Paraffin Wax (solid)	2.0 to 2.5	400	1017
Sulphur	3.9 to 4.2	—	—
Castor Oil	4.7	150	381
Porcelain	4.4	—	—
Quartz	4.5	—	—
Resin	2.5	—	—
Olive Oil	3.1	120	305
Gutta Percha	3.3 to 4.9	80-200	203-508
Shellac	3.1	—	—
Common Glass	3.1 to 4.0	300-1500	762-3810
Turpentine	2.23	110-160	280-406
Dry Oak Wood	2.5 to 6.8	—	—
Formica Bakelite, etc.	5 to 6	—	—

Inductive and Capacitive Reactance

The formula for inductive reactance is:

$$X_L = 2\pi fL$$

The Radio Amateur's Handbook

where X_L is the inductive reactance in ohms
 π is 3.1416

f is the frequency in cycles per second

L is the inductance in henrys.

From this it is evident that inductive reactance is directly proportional to frequency and directly proportional to the value of inductance.

The capacitive reactance formula is:

$$X_C = \frac{1}{2\pi f C_{fd}}$$

where: X_C is the capacitive reactance in ohms
 π is 3.1416

f is the frequency in cycles per second

C_{fd} is the condenser capacitance in farads.

Where the capacitance is in microfarads ($\mu\text{fd.}$), as it is in most practical cases, the formula becomes

$$X_C = \frac{10^6}{2\pi f C_{\mu fd}}$$

10^6 being 1,000,000.

Resistance-Capacitance Time Constant (RC)

If a charged condenser had infinite resistance between its plates, it would hold the charge indefinitely at its initial value. However, since all practical condensers do have more or less definite resistance (through the dielectric and between the connecting terminals), the charge gradually leaks off. Good condensers have a very high "leakage resistance," however, and will hold a charge for days if left undisturbed.

In a circuit containing only capacitance and resistance, the time required for the potential difference between the charged plates of a condenser to fall to a definite percentage of its initial value is determined by the capacitance of the condenser and the value of the resistance. The relation is of practical importance in many circuit applications in amateur transmission and reception, as in time delay with automatic volume control, resistance-capacitance filters, etc. For the voltage to fall to 37% (0.37) of its initial value,

$$t = RC,$$

where t is the time in *microseconds* (millionths of a second), R is the resistance in ohms, and C is the capacitance in microfarads. RC should be divided by 1 million to give the answer in seconds. This is called the *time constant* of the combination. The time required for the voltage to fall to one-tenth (10%) of its initial value can be found by multiplying RC , as given above, by 2.4.

Time constant, t , for 90% fall in voltage
 $= 2.4 \frac{RC}{10^6}$, t being in *seconds*, R in *ohms* and C in $\mu\text{fd.}$

Condensers in Series and Parallel

Capacitances can be connected in series or in parallel like resistances or inductances, as shown in the diagram. However, connecting condensers in parallel makes the total capaci-

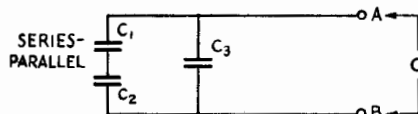
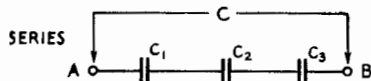
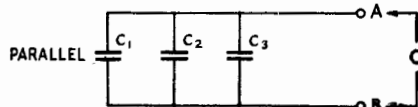

DIAGRAMS OF SERIES, PARALLEL AND SERIES-PARALLEL CAPACITANCE CONNECTIONS

tance *greater* while in the case of resistance and inductance, the value is lessened by making a parallel connection.

The equivalent capacity of condensers connected in parallel is the sum of the capacities of the several condensers so connected:

$$C = C_1 + C_2 + C_3.$$

The equivalent capacity of condensers connected in series is expressed by the following formula:

$$\frac{1}{C} = \frac{1}{C_1} + \frac{1}{C_2} + \frac{1}{C_3}.$$

When but two condensers are connected in series, the following expression can be used:

$$C = \frac{C_1 C_2}{C_1 + C_2}.$$

Where the net capacitance of a series-parallel combination is to be found, the capacitance of the series groups can be worked out separately and then added in parallel combination. As is also true in the case of resistances in parallel, the Series-Parallel type *Lightning Calculator* is a useful aid in making such determinations.

The Decibel

The decibel (abbreviated *db*) is a convenient unit for the measurement of electrical or acoustic power ratios on a logarithmic scale. The number of decibels equivalent to the ratio between two amounts of power is:

$$db = 10 \log_{10} \frac{P_1}{P_2}.$$

Since the decibel is a logarithmic unit, suc-

Tube Characteristics and Miscellaneous Data

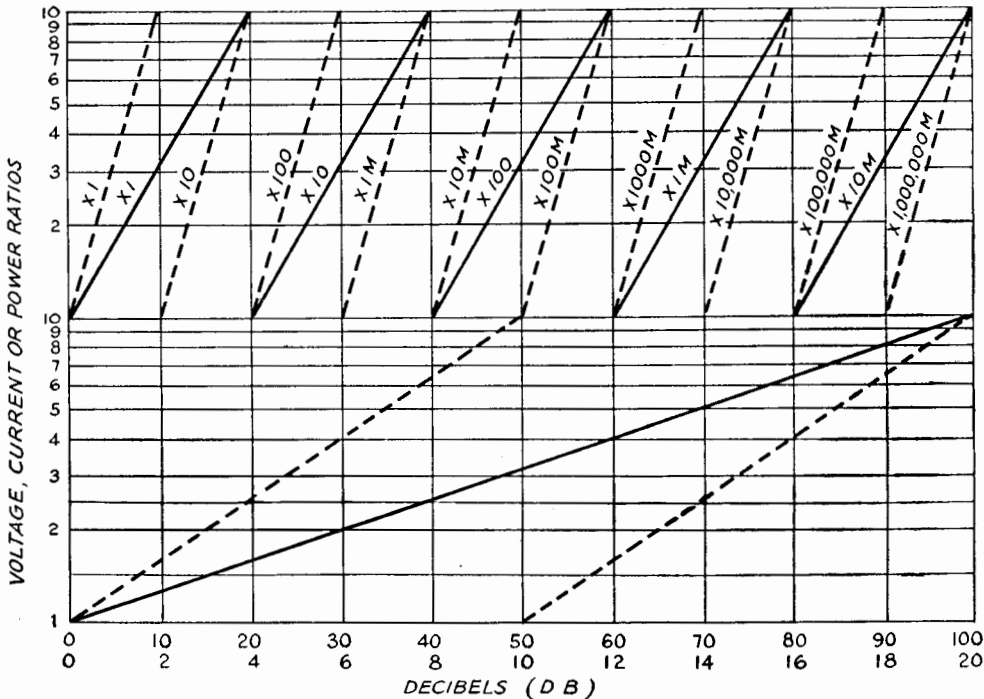

cessive gains and losses expressed in db can be added algebraically. If the ratio of the two power values is greater than 1 there is a power gain; if the ratio is less than 1 there is a loss of power. A gain is expressed in "plus db"; a loss in "minus db."

The decibel also can be used to express ratios between voltages and currents provided the circuit conditions are the same for the two quantities whose magnitudes are being compared; i.e., if the impedances and power factors of the circuits are the same.

The decibel is primarily a unit which specifies gains or losses with reference to the power value at some point in a system regardless of the actual value of the reference power. In telephone and radio work, however, it is convenient to assume a reference power level and express the power at a point in a circuit in terms of "plus db" or "minus db" above or below this reference level. A standard reference level in radio work is 0.006 watt, or 6 milliwatts.

The chart above is direct-reading in terms of decibels for all power, voltage or current ratios. The top scale goes from 0 to 100 db and is useful for very large ratios; the lower scale permits closer reading between 0 and 20 db, or one cycle of the extended scale. Solid lines show voltage or current ratios; dotted lines, power ratios. To find db gain, divide output power by corresponding input power and read db value for this ratio, using the appropriate curve (i.e.,

" $\times 1$ " for ratios from 1 to 10, " $\times 10$ " for ratios from 10 to 100, " $\times 100$ " for ratios from 100 to 1000, and so on). To find db loss, as where output is less than input, divide input value by output value. Current and voltage ratios in db can be found similarly, provided the input and output impedances are the same. Power, voltage and current values must be in the same units (watts, millivolts, microamperes, etc.).

Color Code for Resistors and Condensers

A standard color code is used for identification of resistance and capacitance values of small carbon-type resistors and midget mica condensers. In this code, numbers are represented by the following colors:

0 — Black	5 — Green
1 — Brown	6 — Blue
2 — Red	7 — Violet
3 — Orange	8 — Gray
4 — Yellow	9 — White

Three colors are used on each resistor to identify its value. The body color represents the first figure of the resistance value; one end or tip is colored to represent the second figure; a colored band or dot near the center of the resistor gives the number of zeros following the first two figures. A 25,000-ohm resistor, for example, would be marked as follows: body, red (2); tip, green (5); dot, orange (3 zeros).

The Radio Amateur's Handbook

Small mica condensers usually are marked with three colored dots, with an arrow or other symbol indicating the sequence of colors. Readings are in micromicrofarads ($\mu\mu\text{fd.}$), with the color code same as above. For example, a 0.00025- $\mu\text{fd.}$ (250- $\mu\mu\text{fd.}$) condenser would be marked as follows: red (2), green (5), brown (1 zero).

Metric Prefixes

μ	$\frac{1}{1,000,000}$	One-millionth	micro-
m	$\frac{1}{1,000}$	One-thousandth	milli-
c	$\frac{1}{100}$	One-hundredth	centi-
d	$\frac{1}{10}$	One-tenth	deci-
	1	One	uni-
dk	10	Ten	deka-
h	100	One hundred	hekto-
k	1,000	One thousand	kilo-
	10,000	Ten thousand	myria-
M	1,000,000	One million	mega-

Conversion Factors

Ampere	= 1,000,000 microamperes
Ampere	= 1,000 milliamperes
Cycle	= .000,001 megacycle
Cycle	= .001 kilocycle
Farad	= 1,000,000,000,000 micromicrofarads
Farad	= 1,000,000 microfarads
Farad	= 1,000 millifarads
Henry	= 1,000,000 microhenrys

Henry	= 1,000 millihenrys
Kilocycle	= 1,000 cycles
Kilovolt	= 1,000 volts
Kilowatt	= 1,000 watts
Megacycle	= 1,000,000 cycles
Megohm	= 1,000,000 ohms
Mho	= 1,000,000 micromhos
Mho	= 1,000 millimhos
Microampere	= .000,001 ampere
Microfarad	= .000,001 farad
Microhenry	= .000,001 henry
Micromho	= .000,001 mho
Micro-ohm	= .000,001 ohm
Microvolt	= .000,001 volt
Microwatt	= .000,001 watt
Micromicrofarad	= .000,000,000,001 farad
Micromicro-ohm	= .000,000,000,001 ohm
Milliampere	= .001 ampere
Millihenry	= .001 henry
Millimho	= .001 mho
Milliohm	= .001 ohm
Millivolt	= .001 volt
Milliwatt	= .001 watt
Volt	= 1,000,000 microvolts
Volt	= 1,000 millivolts
Watt	= 1,000,000 microwatts
Watt	= 1,000 milliwatts
Watt	= .001 kilowatt

Equivalents of Electrical Units

1 kilowatt	= 1000 watts.
1 kilowatt	= 1.34 H. P.
1 kilowatt	= 44,257 foot-pounds per minute.
1 kilowatt	= 56.87 B. t. u. per minute.
1 horse power	= 746 watts.
1 horse power	= 33,000 foot-pounds per minute.
1 horse power	= 42.41 B. t. u. per minute.
1 B. t. u. (British thermal unit)	= 778 foot-pounds.
1 B. t. u.	= 0.2930 watt-hour.
1 joule	= 1 watt-second.

Symbols for Electrical Quantities

Admittance	Y, y
Angular frequency or velocity (πf)	ω
Capacitance	C
Conductance	G, g
Conductivity	ν

ABBREVIATIONS FOR ELECTRICAL AND RADIO TERMS

Alternating current	a.c.	Megohm	M Ω
Ampere (amperes)	a.	Meter	m.
Antenna	ant.	Microfarad	$\mu\text{fd.}$
Audio frequency	a.f.	Microhenry	$\mu\text{h.}$
Centimeter	cm.	Micromicrofarad	$\mu\mu\text{fd.}$
Continuous waves	c.w.	Microvolt	$\mu\text{v.}$
Cycles per second	c.p.s.	Microvolt per meter	$\mu\text{v./m.}$
Decibel	db	Microwatt	$\mu\text{w.}$
Direct current	d.c.	Milliampere	ma.
Electromotive force	e.m.f.	Millivolt	mv.
Frequency	f.	Milliwatt	mw.
Ground	gnd.	Modulated continuous waves	m.c.w.
Henry	h.	Ohm	Ω
High frequency	h.f.	Power	P.
Intermediate frequency	i.f.	Power factor	p.f.
Interrupted continuous waves	i.c.w.	Radio frequency	r.f.
Kilocycles (per second)	kc.	Ultra-high frequency	u.h.f.
Kilowatt	kw.	Volt (volts)	v.
Megacycle (per second)	Mc.	Watt (watts)	w.

Tube Characteristics and Miscellaneous Data

SCHEMATIC SYMBOLS USED IN CIRCUIT DIAGRAMS

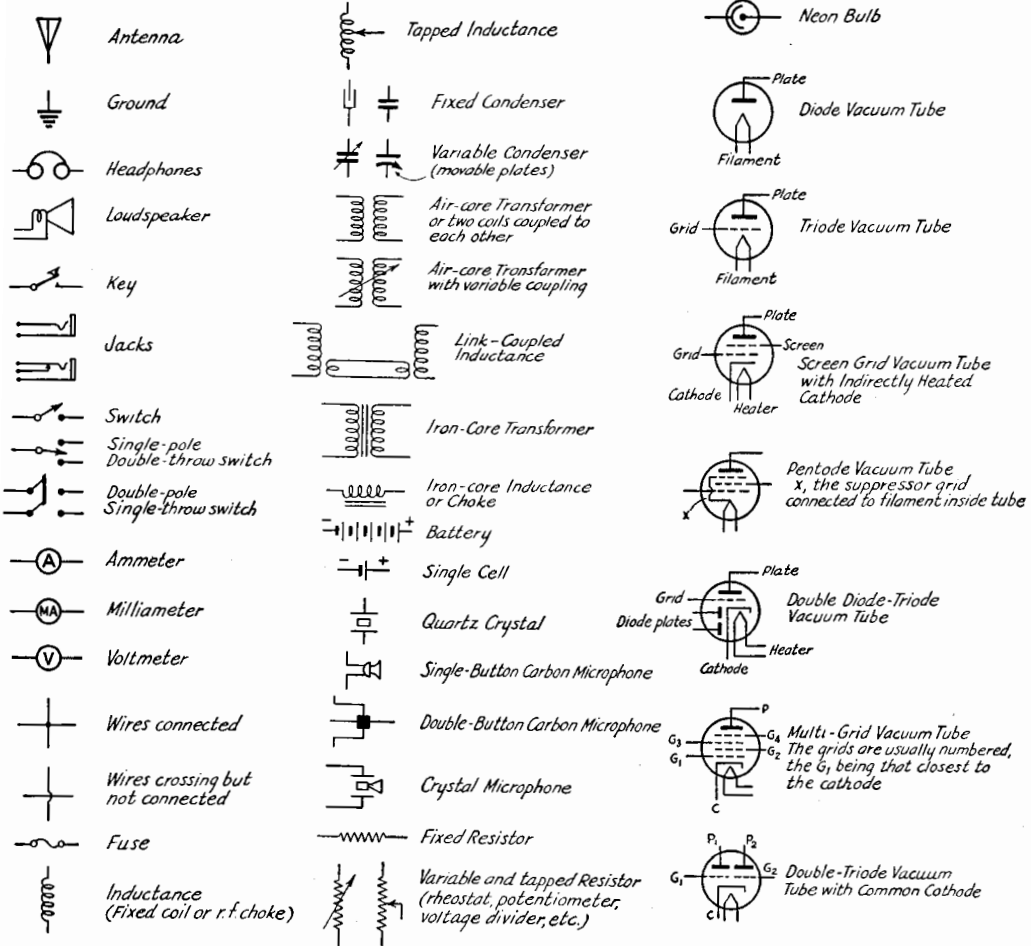

- Current
- Difference of potential
- Dielectric constant
- Energy
- Frequency
- Impedance
- Inductance
- Magnetic intensity
- Magnetic flux
- Magnetic flux density
- Mutual inductance
- Number of conductors or turns
- Permeability
- Phase displacement
- Power
- Quantity of electricity
- Reactance
- Resistance
- Resistivity
- Susceptance
- Speed of rotation
- Voltage
- Work

- I, i
- E, e
- K or ϵ
- W
- f
- Z, z
- L
- H
- Φ
- B
- M
- N
- μ
- θ or Φ
- P, p
- Q, q
- X, x
- R, r
- P
- b
- n
- E, e
- W

Letter Symbols for Vacuum Tube Notation

- Grid potential E_u, e_e
- Grid current I_u, i_u
- Grid conductance g_u
- Grid resistance r_u
- Grid bias voltage E_e
- Plate potential E_p, e_p
- Plate current I_p, i_p
- Plate conductance g_p
- Plate resistance r_p
- Plate supply voltage E_b
- Emission current I_s
- Mutual conductance g_m
- Amplification factor μ
- Filament terminal voltage E_f
- Filament current I_f
- Grid-plate capacity C_{op}
- Grid-cathode capacity C_{ok}
- Plate-cathode capacity C_{pk}
- Grid capacity (input) C_g
- Plate capacity (output) C_p

NOTE. — Small letters refer to instantaneous values.

The Radio Amateur's Handbook

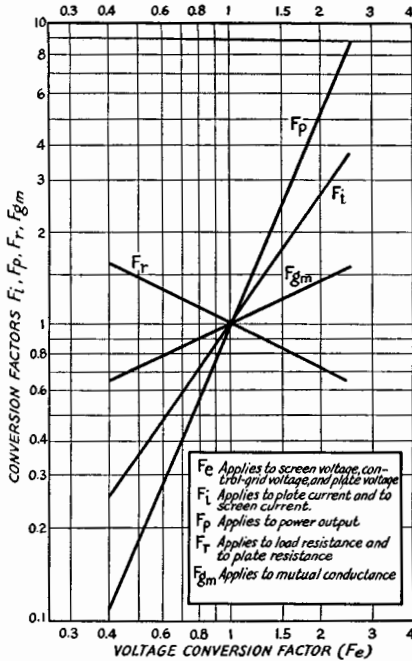

← Conversion factors for power amplifier triodes and pentodes. Using the operating conditions shown in the tube data tables which follow, equivalent conditions involving special plate voltage requirements can be determined. To use these curves, first determine the ratio of the new plate voltage to that shown in the table. This ratio, the voltage conversion factor (F_e), is then used to determine the new screen- and control-grid voltages and the other significant characteristics for the new operating condition.

Reactance chart (below). The approximate reactance in ohms of any capacity from 10 $\mu\text{fd.}$ to 10 $\mu\text{fd.}$ at any frequency from 100 cycles to 100 megacycles can be read directly from the chart. Intermediate values can be estimated by interpolation. In making interpolations, it should be remembered that the rate of change between the capacity lines is logarithmic, like the frequency and reactance scales; e.g., a point half-way between 1.0 and 10 $\mu\text{fd.}$ represents approximately 3.0 $\mu\text{fd.}$

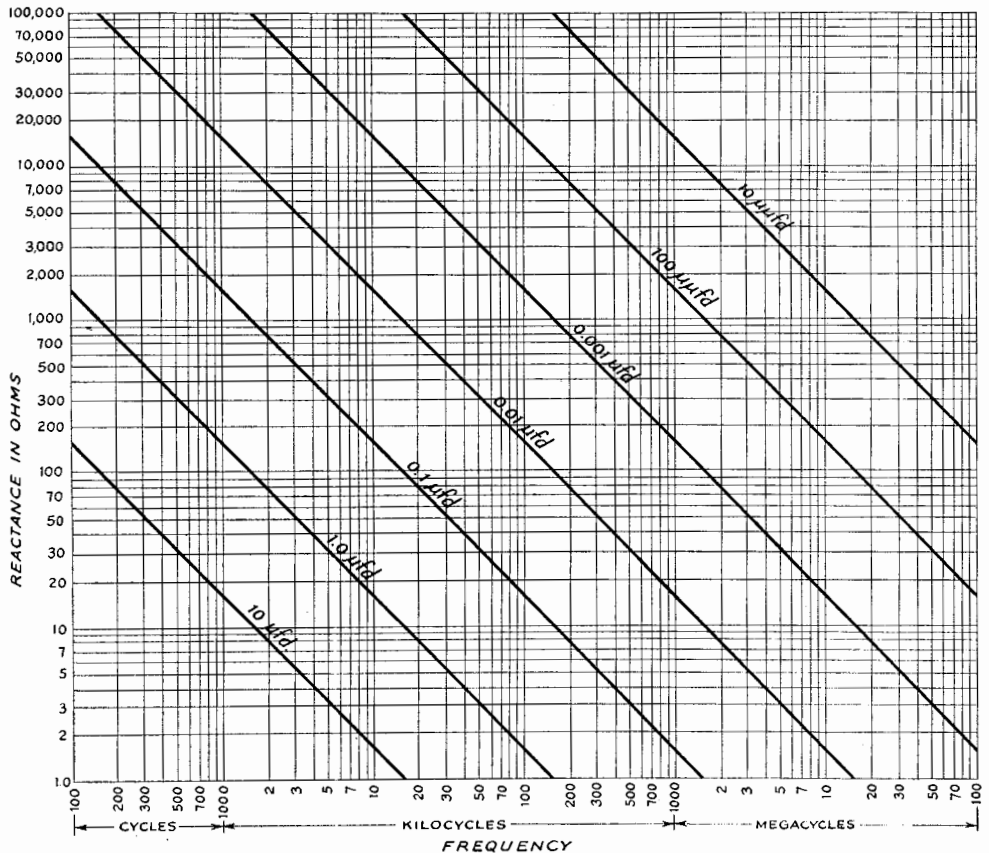

Tube Characteristics and Miscellaneous Data

COPPER WIRE TABLE

Gauge No. B. & S.	Diam. in Mils. ¹	Circular Mil Area	Turns per Linear Inch ²			Turns per Square Inch ²			Feet per Lb.		Okms per 1000 ft. 25° C.	Current Carrying Capacity at 1500 C.M. per Amp. ³	Diam. in mm.	Nearest British S.W.G. No.
			Enamel	S.C.C.	D.S.C. or S.C.C.	D.C.C.	Enamel S.C.C.	D.C.C.	Bare	D.C.C.				
1	289.3	83690	—	—	—	—	—	—	3.947	—	.1264	55.7	7.348	1
2	257.6	66370	—	—	—	—	—	—	4.977	—	.1593	44.1	6.544	3
3	229.4	52640	—	—	—	—	—	—	6.276	—	.2009	35.0	5.827	4
4	204.3	41740	—	—	—	—	—	—	7.914	—	.2533	27.7	5.189	5
5	181.9	33100	—	—	—	—	—	—	9.980	—	.3195	22.0	4.621	7
6	162.0	26250	—	—	—	—	—	—	12.58	—	.4028	17.5	4.115	8
7	144.3	20820	—	—	—	—	—	—	15.87	—	.5080	13.8	3.665	9
8	128.5	16510	7.6	—	—	—	—	—	20.01	—	.6405	11.0	3.264	10
9	114.4	13090	8.6	—	7.4	—	—	—	25.23	—	.8077	8.7	2.906	11
10	101.9	10880	9.6	—	8.2	7.8	—	—	31.82	—	1.018	6.9	2.588	12
11	90.74	8234	10.7	—	9.3	8.9	—	87.5	40.12	80.0	1.284	5.5	2.305	13
12	80.81	6530	12.0	—	10.3	9.8	—	105	50.59	97.5	1.619	4.4	2.053	14
13	71.96	5178	13.5	—	11.5	10.9	—	131	63.80	121	2.042	3.5	1.828	15
14	64.08	4107	15.0	—	12.8	12.0	—	162	80.44	150	2.575	2.7	1.628	16
15	57.07	3257	16.8	—	14.2	13.8	—	198	101.4	183	3.247	2.2	1.450	17
16	50.82	2583	18.9	—	15.8	14.7	—	250	127.9	223	4.094	1.7	1.291	18
17	45.26	2048	21.2	—	17.9	16.4	—	306	161.3	271	5.163	1.3	1.150	19
18	40.30	1624	23.6	—	19.9	18.1	—	397	203.4	329	6.510	1.1	1.024	20
19	35.89	1288	26.4	—	22.0	19.8	—	483	256.5	399	8.210	.86	.9116	21
20	31.96	1022	29.4	—	24.4	21.8	—	553	323.4	479	10.35	.68	.8118	22
21	28.46	810.1	32.7	—	27.0	23.8	—	725	407.8	625	13.05	.54	.7230	23
22	25.35	642.4	37.0	—	29.8	26.0	—	895	514.2	754	16.46	.43	.6438	24
23	22.57	509.5	41.3	—	32.7	30.0	—	1070	648.4	910	20.76	.34	.5733	25
24	20.10	404.0	46.3	—	36.5	31.6	—	1300	817.7	1080	26.17	.27	.5106	26
25	17.90	320.4	51.7	—	40.6	35.6	—	1570	1031	1260	33.00	.21	.4547	27
26	15.94	254.1	58.0	—	45.6	38.6	—	1910	1300	1510	41.62	.17	.4049	28
27	14.20	201.5	64.9	—	50.4	41.8	—	2060	1639	1750	52.48	.13	.3606	29
28	12.64	159.8	72.7	—	55.0	45.0	—	2780	2067	2020	66.17	.11	.3211	30
29	11.26	126.7	81.6	—	60.2	48.5	—	3350	2607	2310	83.44	.084	.2859	31
30	10.03	100.5	91.5	—	65.4	51.8	—	4000	3900	2607	105.2	.067	.2546	32
31	8.928	79.70	101.5	—	71.5	55.5	—	4660	5040	3000	132.7	.053	.2268	33
32	7.950	63.21	113	—	77.5	59.2	—	5290	6290	3700	167.3	.042	.2019	34
33	6.980	50.13	127	—	83.6	62.6	—	7060	8310	4297	211.0	.033	.1798	35
34	6.305	39.75	143	—	90.3	66.3	—	8120	9310	4697	266.0	.028	.1601	36
35	5.615	31.52	158	—	97.0	70.0	—	9600	8310	5227	335.0	.021	.1426	37
36	5.000	25.00	175	—	104	73.5	—	10900	10480	5737	423.0	.017	.1270	38
37	4.453	19.83	198	—	111	77.0	—	12200	13210	6168	533.4	.013	.1131	39
38	3.965	15.72	224	—	118	80.3	—	16660	16660	7877	672.6	.010	.1007	40
39	3.531	12.47	248	—	126	86.6	—	21010	21010	10666	848.1	.008	.0897	41
40	3.145	9.88	282	—	140	89.7	—	33410	33410	11907	1069	.006	.0799	42
														43
														44

1 A mil is 1/1000 (one thousandth) of an inch.
 2 The figures given are approximate only, since the thickness of the insulation varies with different manufacturers.
 3 The current-carrying capacity at 1000 C.M. per ampere is equal to the circular-mil area (Column 3) divided by 1000.

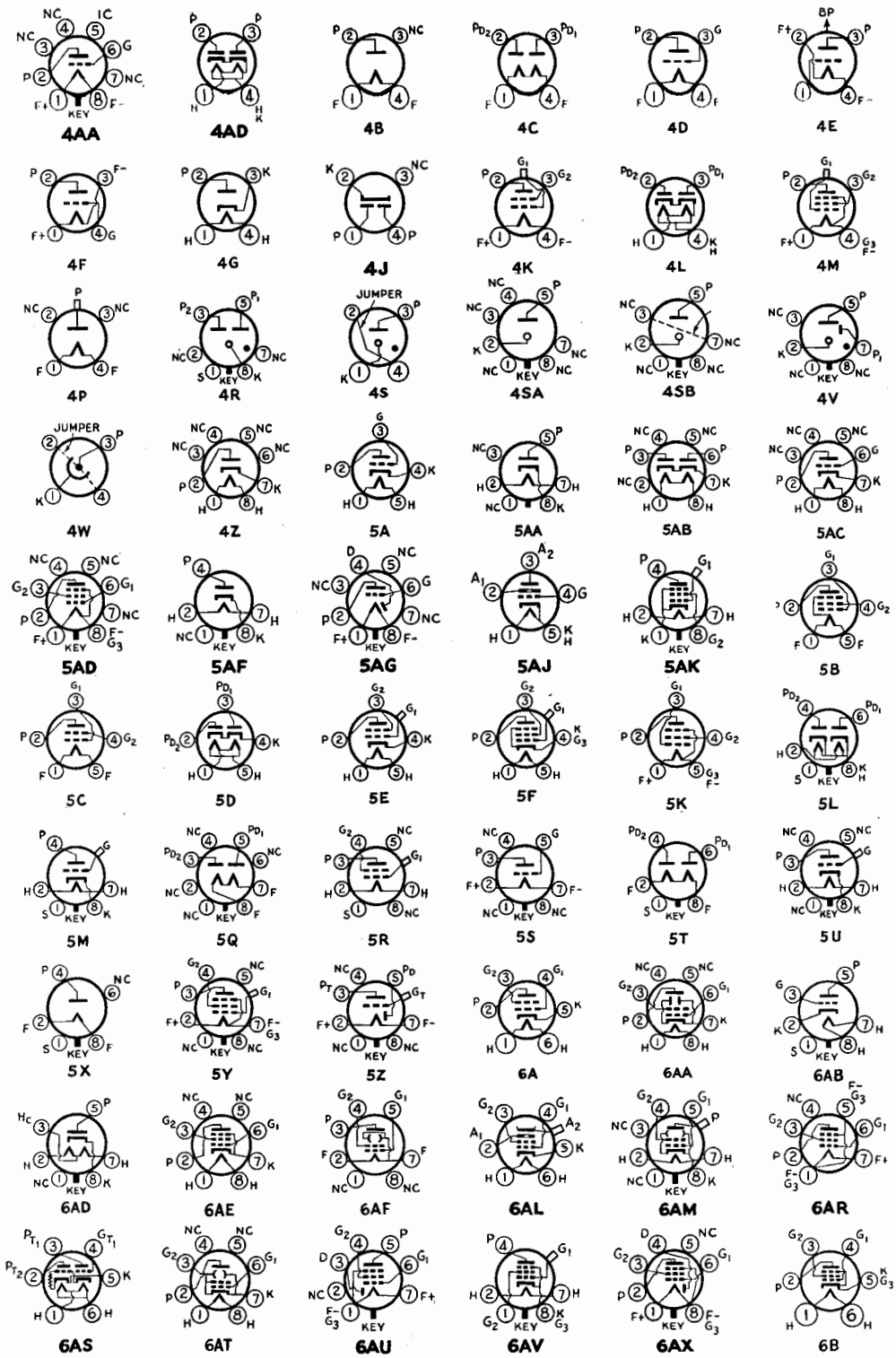

RECEIVING TUBE DIAGRAMS

Bottom views are shown. Terminal designations on sockets are as follows:

BP = Bayonet Pin	H = Heater	P = Plate (Anode)	S = Shell
F = Filament	K = Cathode	P ₁ = Starter-Anode	TA = Target
G = Grid	NC = No Connection	PBF = Beam-Forming Plates	● = Gas-Type Tube
RC = Ray-Control Electrode	IC = Internal Connection	U = Unit	

Alphabetical subscripts D, P, T and HX indicate, respectively, diode unit, pentode unit, triode unit or hexode unit in multi-unit types.

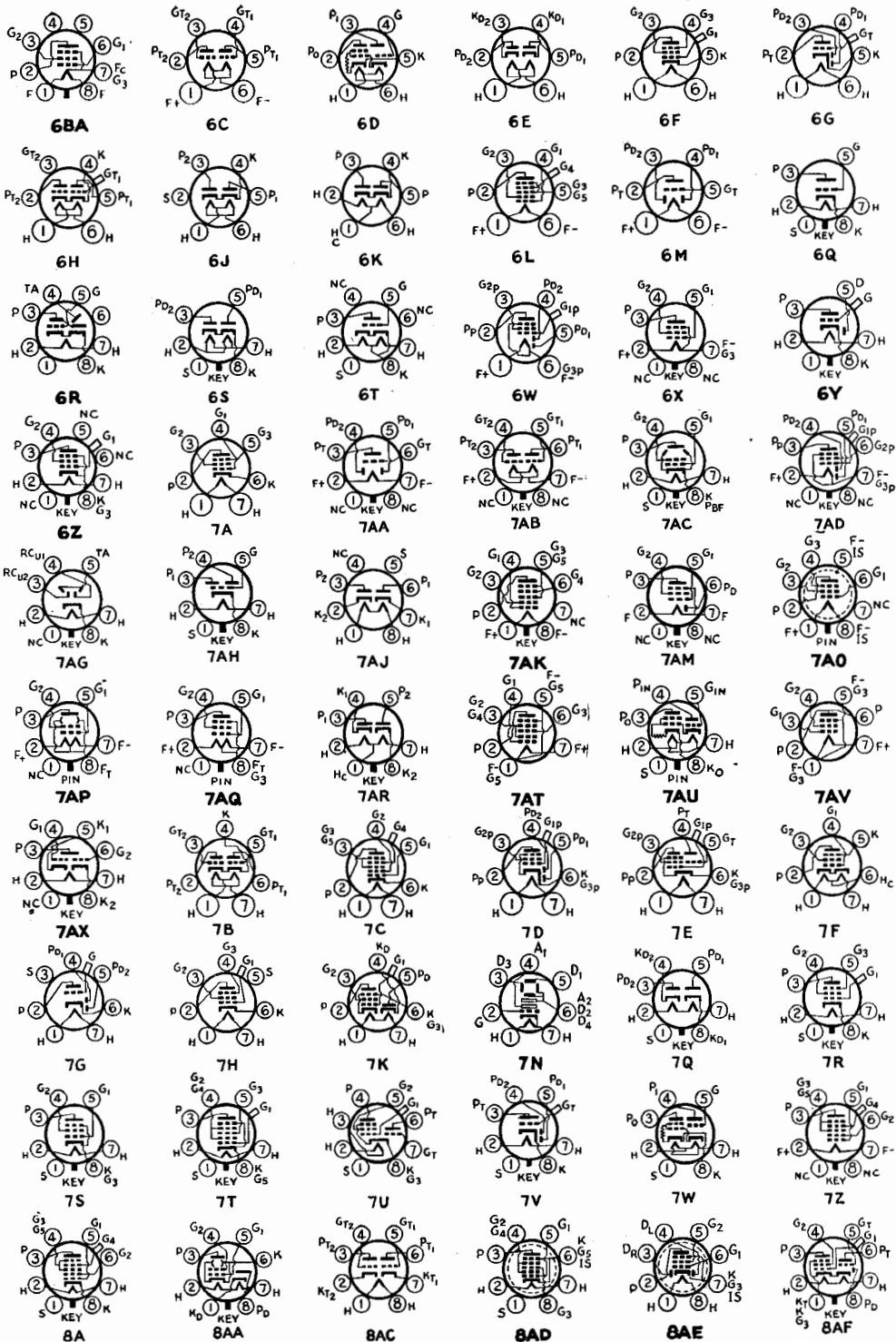

RECEIVING TUBE DIAGRAMS

Bottom views are shown. Terminal designations on sockets are as follows:

- | | | | |
|----------------------------|--------------------|---------------------------------------|-------------------|
| BP = Bayonet Pin | H = Heater | P = Plate (Anode) | S = Shell |
| F = Filament | K = Cathode | P ₁ = Starter-Anode | TA = Target |
| G = Grid | NC = No Connection | P _{BF} = Beam-Forming Plates | ● = Gas-Type Tube |
| RC = Ray-Control Electrode | | | U = Unit |

Alphabetical subscripts D, P, T and HX indicate, respectively, diode unit, pentode unit, triode unit or hexode unit in multi-unit types.

The Radio Amateur's Handbook

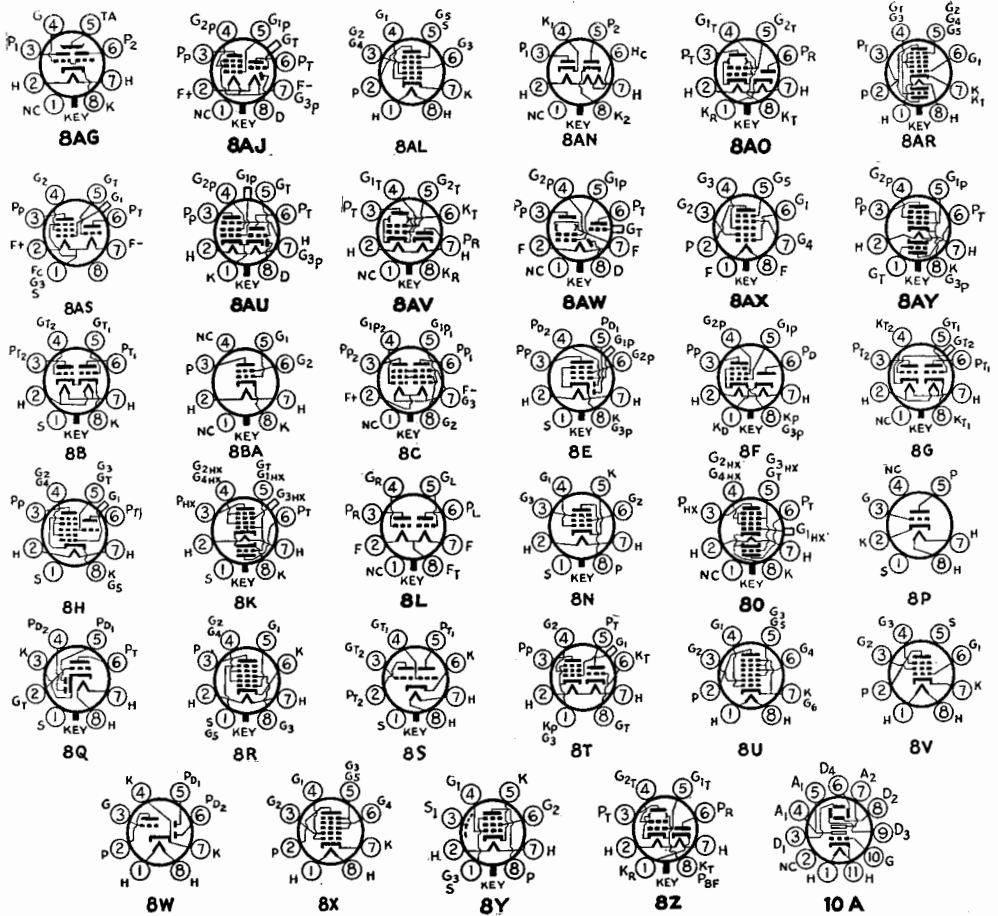

RECEIVING TUBE DIAGRAM

Bottom views are shown. Terminal designations on sockets are as follows:

- | | | |
|----------------------------|--------------------|---------------------------------------|
| BP = Bayonet Pin | H = Heater | P = Plate (Anode) |
| F = Filament | K = Cathode | P ₁ = Starter-Anode |
| G = Grid | NC = No Connection | P _{BR} = Beam-Forming Plates |
| RC = Ray-Control Electrode | | |

- | |
|-------------------|
| S = Shell |
| TA = Target |
| ● = Gas-Type Tube |
| U = Unit |

Alphabetical subscripts D, P, T and HX indicate, respectively, diode unit, pentode unit, triode unit or hexode unit in multi-unit types.

SOCKET CONNECTIONS FOR ACORN TUBES

Bottom views — looking at short end.

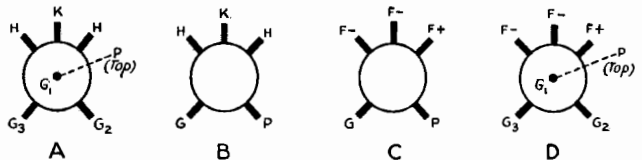

Tube Characteristics and Miscellaneous Data

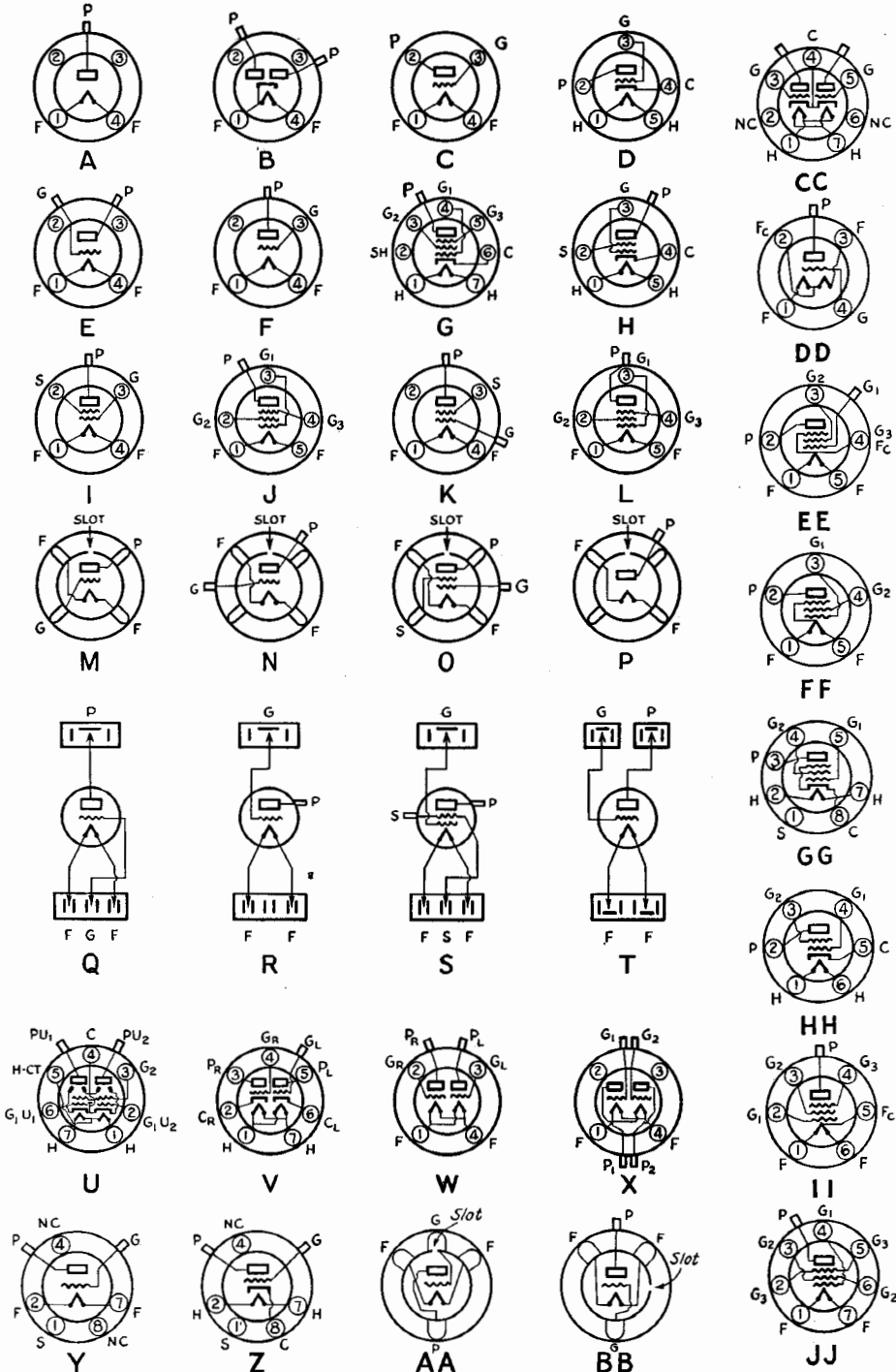

TRANSMITTING TUBE BASE DIAGRAMS

Bottom views are shown. F denotes filament, H heater, C cathode, G grid, S screen (or shell in octal-based tubes), P plate, G₁, G₂, G₃, etc., denote grids numbered in order from cathode outward; numeral subscripts in multi-unit tubes denote elements common to one unit.

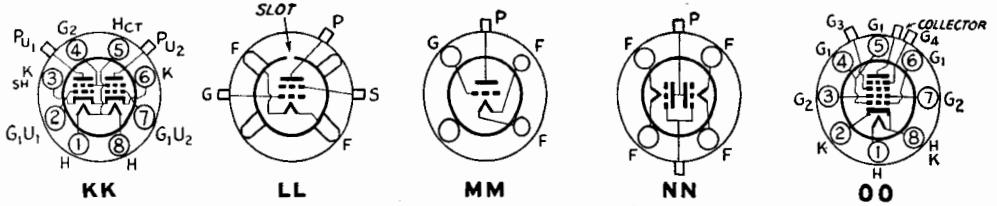

TRANSMITTING TUBE BASE DIAGRAMS

Bottom views are shown. F denotes filament, H heater, C cathode, G grid, S screen (or shell in octal-based tubes), P plate. G₁, G₂, G₃, etc., denote grids numbered in order from cathode outward; numeral subscripts in multi-unit tubes denote elements common to one unit.

Relative Electrical Conductivity of Metals at Ordinary Temperatures

(Based on Copper as 100)

Aluminum (2S; pure)	59	Iron (cast)	2-12
Aluminum (alloys):		Iron (wrought)	11.4
Soft-annealed	45-50	Lead	7
Heat-treated	30-45	Manganin	3.7
Brass	28	Mercury	1.66
Cadmium	19	Molybdenum	33.2
Chromium	55	Nichrome	4
Climax	1.83	Nickel	12-16
Cobalt	16.3	Phosphor Bronze	36
Constantin	3.24	Platinum	15
Copper (hard drawn)	89.5	Silver	106
Copper (annealed)	100	Steel	3-15
Everdur	6	Tin	13
German Silver (18%)	5.3	Tungsten	28.9
Gold	65	Zinc	28.2
Iron (pure)	17.7		

Approximate relations:

An increase of 1 in A.W.G. or B. & S. wire size increases resistance 25%.

An increase of 2 increases resistance 60%.

An increase of 3 increases resistance 100%.

An increase of 10 increases resistance 10 times.

Current Capacity of Power Wiring

The National Board of Fire Underwriters has established the following as maximum current densities for commonly-used sizes of copper wire in electrical power circuits:

Gauge No. B. & S.	Circular Mil Area	Amperes	
		Rubber Insulation	Other Insulation
1	83690	100	150
2	66370	90	125
4	41740	70	90
6	26250	50	70
8	16510	35	50
10	10380	25	30
12	6530	20	25
14	4107	15	20
16	2583	6	10
18	1624	3	6

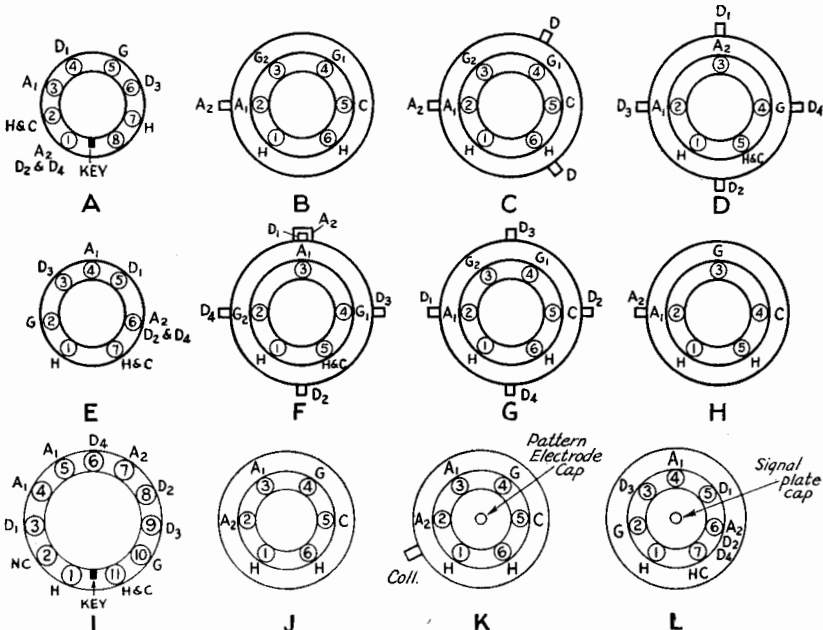

SOCKET CONNECTIONS FOR CATHODE-RAY TUBES

H denotes heater, C cathode, G grid, A anode, D deflecting plate, COLL collector. Inner rings of base diagram indicate socket connections; connections on outer ring indicate bulb cap-type terminals. Views are from bottoms of tubes.

TABLE I — METAL RECEIVING TUBES

Characteristics given in this table apply to all tubes having type numbers shown, including metal tubes, glass tubes with "G" suffix, and bantam tubes with "GT" suffix. For "G" and "GT" tubes not listed (not having metal counterparts), see Tables I, VII, VIII and IX.

Type	Name	Socket Connections ¹	Cathode	Fil. or Heater		Use	Plate Supply Volts	Grid Bias	Screen Volts	Screen Current Ma.	Plate Current Ma.	Plate Resistance, Ohms	Transconductance Micromhos	Amp. Factor	Load Resistance Ohms	Power Output Watts	Type
				Volts	Amps.												
6A8	Pentagrid Converter	8A	Htr.	6.3	0.3	Osc.-Mixer	250	- 3.0	100	3.2	3.3	Anode-grid (No. 2) 250 volts max. thru 20,000-ohms	3500	—	—	6A8	
6AB7 1853	Television Amp. Pentode	8N	Htr.	6.3	0.45	Class-A Amplifier	300	- 3.0	200 ²	3.2	12.5	700000	—	—	—	6AB7 1853	
6AC7 1852	Television Amp. Pentode	8N	Htr.	6.3	0.45	Class-A Amplifier	300	- 2.0 ¹	150 ²	2.5	10	750000	6750	—	—	6AC7 1852	
6AG7	Video Beam Power Amp.	8Y	Htr.	6.3	0.65	Class-A ₁ Amplifier ¹⁰ Pentode R.F. Amplifier	250	- 2.0	140	8.5	33	100000	7700	1700	—	6AG7	
6B8	Duplex-Diode Pentode	8E	Htr.	6.3	0.3	Pentode A.F. Amplifier	250	- 3.0	125	2.3	2.0	650000	1125	730	—	6B8	
6C5	Triode Detector, Amplifier	6Q	Htr.	6.3	0.3	Class-A Amplifier	250	- 8.0	—	—	8.0	10000	2000	—	—	6C5	
6F5	High- μ Triode	5M	Htr.	6.3	0.3	Bias Detector	250	- 17.0	—	—	—	Plates current adjusted to 0.2 ma. with no signal	—	—	—	6F5	
6F6	Pentode Power Amplifier	7S	Htr.	6.3	0.7	Class-A Amplifier	250	- 1.3	—	—	0.2	65000	1500	100	—	6F6	
						Class-A Amplifier	250	- 16.5	950	6.5	34	80000	2500	200	7000	3.0	
						Class-A Pentode	315	- 23.0	315	8.0	42	75000	2650	200	7000	5.0	
						Class-A Triode ³	250	- 20	—	—	31	2600	2700	7.0	4000	0.85	
						Push-Pull Class-AB Amp. Pentode Connection Triode Connection ³	375	- 26	250	2.5 ⁴	17 ⁴	Power output for 2 tubes at stated load, plate-to-plate	—	—	10000	19	
						Rectifier	350	- 98	—	—	22.5 ⁴	—	—	—	6000	18	
6H6	Twin Diode	7Q	Htr.	6.3	0.3	Class-A Amplifier	250	- 8	100	—	9	7700	2600	—	—	6H6	
6J5	Detector Amplifier Triode	6Q	Htr.	6.3	0.3	Class-A Amplifier	250	- 3.0	100	0.5	2.0	exceeds 1.5 meg.	1225	—	—	6J5	
6J7	Triple-Grid Detector, Amplifier	7R	Htr.	6.3	0.3	R.F. Amplifier	250	- 4.3	100	—	—	Cathode current 0.43 ma.	—	0.5 meg.	—	6J7	
6K7	Triple-Grid Variable- μ Amplifier	7R	Htr.	6.3	0.3	R.F. Amplifier	250	- 3.0	125	2.6	10.5	600000	1650	990	—	6K7	
6K8	Triode Hexode Converter	8K	Htr.	6.3	0.3	Mixer	250	- 10	100	—	—	—	—	—	—	6K8	
						Osc.-Mixer	250	- 3	100	6	2.5	Triode Plate (No. 2) 100 volts, 3.8 ma.	—	—	—	—	
						Single-Tube Class-A ₁ ⁵ Amp. Fixed Bias	250	- 14.0	250	5.0 ⁴	72 ⁴	22500	6000	135	2500	6.5	
						Class-A ₁ ⁵ Amp. Fixed Bias	375	- 9.0	125	0.7 ⁴	24 ⁴	—	—	—	14000	4.2	
						Class-A ₁ ⁵ Amp. Self Bias	375	- 17.5	250	2.5 ⁴	57 ⁴	—	—	—	4000	11.5	
						Class-A ₁ ⁵ Amp. Self Bias	250	- 13.5	250	5.4 ⁴	75 ⁴	—	—	—	2500	6.5	
						Class-A ₁ ⁵ Amp. Self Bias	300	- 11.8	200	3.0 ⁴	51 ⁴	—	—	—	4500	6.5	
						Class-A ₁ ⁵ Amp. Self Bias	375	- 9.0	125	0.7 ⁴	24 ⁴	—	—	—	14000	4.0	
6L6	Beam Power Amplifier	7AC	Htr.	6.3	0.9	Push-Pull A ₁ ¹⁵ Triode Bias Self Bias	250	- 16	250	10 ⁶	150 ⁶	—	—	—	5000	14.5	
						Push-Pull A ₁ ¹⁵ Self Bias	400	- 25	300	6 ⁶	102 ⁶	—	—	—	5000	13.8	
						Fixed Bias	400	- 20	250	4 ⁶	88 ⁶	—	—	—	6500	34	
						Push-Pull A ₁ ¹⁵ Self-Bias	400	- 23.5	300	7.0 ⁶	112 ⁶	—	—	—	8500	26.5	
						Push-Pull A ₁ ¹⁵ Self-Bias	400	- 19.0	250	4.6 ⁶	96 ⁶	—	—	—	6600	32	
						Push-Pull A ₁ ¹⁵ Fixed Bias	400	- 25	300	6 ⁶	102 ⁶	—	—	—	8500	34	
						Push-Pull A ₁ ¹⁵ Fixed Bias	400	- 20	250	4 ⁶	88 ⁶	—	—	—	3800	60	
6L7	Pentagrid Mixer Amplifier	7T	Htr.	6.3	0.3	R.F. Amplifier	250	- 3.0	100	5.5	5.3	800000	1100	—	—	6L7	
						Mixer	250	- 6.0	150	8.3	3.3	over 1 meg.	Oscillator-grid (No. 3)	—	—	15.0	

TABLE I—METAL RECEIVING TUBES — Continued

Type	Name	Socket Connections ¹	Cathode	Fil. or Heater		Use	Plate Supply Volts	Grid Bias	Screen Volts	Screen Current Ma.	Plate Current Ma.	Plate Resistance, Ohms	Transconductance Micromhos	Amp. Factor	Load Resistance Ohms	Power Output Watts	Type
				Volts	Amps.												
6N7	Twin Triode Amplifier	8B	Htr.	6.3	0.8	Class-B Amplifier	250 300	0	—	—	—	—	—	8000 10000	8.0 10.0	6N7	
6Q7	Duplex-Diode Triode	7V	Htr.	6.3	0.3	Triode Amplifier	250	—3	—	—	1.1	58000	1200	—	—	—	6Q7
6R7	Duplex-Diode Triode	7V	Htr.	6.3	0.3	Triode Amplifier	250	—9	—	—	9.5	8500	1900	—	10000	0.98	6R7
6S7	Triple-Grid Variable- μ	7R	Htr.	6.3	0.15	Class-A Amplifier	250	—3	100	2.0	8.5	1000000	1750	—	—	—	6S7
6SA7	Pentagrid Converter	8R ¹¹	Htr.	6.3	0.3	Osc.-Mixer	250	0 ⁸	100	8.0	3.4	800000	Grid No. 1 Resistor 20000 ohms	—	—	—	6SA7
6SC7	Twin Triode Amplifier	8S	Htr.	6.3	0.3	Class-A Amplifier	250	—2	—	—	2.0	53000	1395	—	—	—	6SC7
6SF5	High- μ Triode	6AB	Htr.	6.3	0.3	Class-A Amplifier	250	—2	—	—	0.9	66000	1500	—	—	—	6SF5
6SJ7	Triple-Grid Amplifier	8N	Htr.	6.3	0.3	Class-A Amplifier	250	—3	100	0.8	3	1500000	1650	—	—	—	6SJ7
6SK7	Triple-Grid Variable- μ	8N	Htr.	6.3	0.3	Class-A Amplifier	250	—3	100	2.4	9.2	800000	3000	—	—	—	6SK7
6SQ7	Duplex-Diode Triode	8Q	Htr.	6.3	0.3	Class-A Amplifier	250	—2	—	—	0.8	91000	1100	—	—	—	6SQ7
6SR7	Duplex-Diode Triode	8Q	Htr.	6.3	0.3	Class-A Amplifier	250	—9	—	—	9.5	1900	1900	—	—	—	6SR7
6T7	Duplex-Diode Triode	7V	Htr.	6.3	0.15	Class-A Amplifier	250	—3	—	—	1.2	69000	1050	—	—	—	6T7
6V6	Beam Power Amplifier	7AC	Htr.	6.3	0.45	Class-A Amplifier	250 300	—15 —20	250 300	4.5/6.5 5/12	46 75	52000	4100	—	5000 10000	4.25 8.5	6V6
1612	Pentagrid Amplifier	7T	Htr.	6.3	0.3	Class-A Amplifier	300	—30	300	6.5 ⁹ /13	38 ⁹ /69	—	—	—	—	—	1612
1620	Triple-Grid Det.-Amp.	7R	Htr.	6.3	0.3	Class-A, Pentode P. P.	300	—30	300	6.5 ⁹ /13	38 ⁹ /69	—	—	—	4000	5.0	1620
1621	Power Amplifier Pentode	7S	Htr.	6.3	0.7	Class-A Triode P. P.	327.5	—27.5 ⁹	—	—	55 ⁹ /59	—	—	—	5000	2.0	1621
1622	Beam Power Amplifier	7AC	Htr.	6.3	0.9	Class-A Amplifier	300	—20	250	4 ⁷ /10.5	86 ⁷ /125	—	—	—	4000	1.0	1622
1851	Television Amp. Pentode	7R	Htr.	6.3	0.45	Class-A Amplifier	300	—2 ⁷	150 ²	2.5	10	750000	9000	—	—	—	1851

¹ See Receiving Tube Diagrams.
² From fixed screen supply. If series resistor from plate supply is used, value for 6A87/1853 is 30,000 ohms for 6AC7/1852 and 1851 60,000 ohms. Series resistor gives variable- μ characteristic; fixed screen supply gives sharp cut-off.
³ Screen tied to plate.
⁴ Zero signal currents per tube.
⁵ Subscript 1 indicates no grid-current flow.
⁶ Subscript 2 indicates grid-current flow over part of input cycle.
⁷ Cathode-bias resistor should be adjusted for plate current of 10 ma.; minimum value 160 ohms.
⁸ Grid bias — 2 volts if separate oscillator excitation is used.
⁹ Cathode resistor 500 ohms.
¹⁰ Typical operation for 4V6, bandwidth video voltage amplifier.
¹¹ For 6SA7GT, see Base Diagram 8AD.

TABLE II—6.3-VOLT GLASS TUBES WITH OCTAL BASES

(For "G" and "GT" -Type Tubes Not Listed Here, See Equivalent Type in Table I; Characteristics and Connections Will Be Identical)

Type	Name	Socket Connections	Cathode	Fil. or Heater		Use	Plate Supply Volts	Grid Bias	Screen Volts	Screen Current Ma.	Plate Current Ma.	Plate Resistance, Ohms	Transconductance Micromhos	Amp. Factor	Load Resistance Ohms	Power Output Watts	Type
				Volts	Amps.												
6A5G	Triode Power Amplifier	6T	Htr.	6.3	1.0	Class-A Amplifier	250	—45	—	—	60	800	—	—	3.75	6A5G	
6AB6G	Direct-Coupled Amplifier	7W	Htr.	6.3	0.5	Push-Pull Class AB	395	—68	—	—	80 ²	—	5950	—	3000	15	6AB6G
6AC5G	High- μ Power Amplifier Triode	6Q	Htr.	6.3	0.4	Class-A Amplifier	250	0	—	—	34	—	1800	—	8000	3.5	6AC5G
6AC6G	Direct-Coupled Amplifier	7W	Htr.	6.3	1.1	Dynamic-Coupled Amp.	180	0	—	—	32	—	3400	—	10000	3.7	6AC6G

TABLE II — 6.3-VOLT GLASS TUBES WITH OCTAL BASES — Continued

Type	Name	Socket Connections ¹	Cathode	Fil. or Heater Volts	Amps.	Use	Plate Supply Volts	Grid Bias	Screen Volts	Screen Current Ma.	Plate Current Ma.	Plate Resistance, Ohms	Transconductance, Micromhos	Amp. Factor	Load Resistance, Ohms	Power Output Watts	Type
6AD5G	High- μ Triode	6Q	Htr.	6.3	0.3	Class-A Amplifier	250	-2.0	—	—	0.9	—	1500	100	—	—	6AD5G
6AD6G	Electron-Ray Tube	7AG	Htr.	6.3	0.15	Indicator Tube	100	—	—	—	—	—	—	—	—	—	6AD6G
6AD7G	Triode-Pentode	8AY	Htr.	6.3	0.85	Pentode Amplifier	250	-16.5	250	6.5	34	80000	325	6	7000	3.2	6AD7G
6AE5G	Triode Amplifier	6Q	Htr.	6.3	0.3	Class-A Amplifier	95	-1.5	—	—	7.0	—	1200	4.2	—	—	6AE5G
6AE6G	Control Tube	7AH	Htr.	6.3	0.15	Indicator Control	250	-1.5	—	—	6.5	—	1000	25	—	—	6AE6G
6AE7G	Double Triode ⁷	7AX	Htr.	6.3	0.5	Driver Amplifier	250	-13.5	—	—	5.0	9300	1500	14	—	—	6AE7G
6AF5G	Triode Amplifier	6Q	Htr.	6.3	0.3	Class-A Amplifier	100	-18	—	—	7.0	—	1500	7.4	—	—	6AF5G
6AF6G	Electron-Ray Tube	7AG	Htr.	6.3	0.15	Indicator Tube	100	—	—	—	—	—	—	—	—	—	6AF6G
6AF7G	Twin Electron Ray	7AG	Htr.	6.3	0.3	Indicator Tube	100	—	—	—	—	—	—	—	—	—	6AF7G
6AG6G	Power Amplifier Pentode	7S	Htr.	6.3	1.25	Class-A Amplifier	250	-6	250	6.0	32	—	10000	—	8500	3.75	6AG6G
6AL6G	Beam Power Amplifier	6AM	Htr.	6.3	0.9	Class-A Amplifier	250	-14	250	5.0	72	29500	6000	—	2500	6.5	6AL6G
6B4G	Triode Power Amplifier	5S	Fil.	6.3	1.0	Power Amplifier	250	-3.0	—	—	—	—	—	—	—	—	6B4G
6B6G	Duplex-Diode High- μ Triode	7V	Htr.	6.3	0.3	Detector-Amplifier	250	-4.5	—	—	3.1	26000	1450	38	—	—	6B6G
6C8G	Twin Triode	8G	Htr.	6.3	0.3	Amp. 1 Section Inv. 2 Sections	250	-3.0	—	—	1.7 ⁹	—	Output — 60v. R.M.S. Output — 80v. R.M.S.	—	—	—	6C8G
6D8G	Pentagrid Converter	8A	Htr.	6.3	0.15	Converter	135 250	-3.0 -3.0 min.	67.5 100	Cathode current 8.0 Ma. Cathode current 13.0 Ma.	—	—	—	—	—	—	6D8G
6E8G	Triode-Hexode Converter	8O	Htr.	6.3	0.3	Osc.-Mixer	250	-2	—	—	—	—	Triode Plate 150 volts	—	—	—	6E8G
6F8G	Twin Triode	8G	Htr.	6.3	0.6	Amplifier	250	-8.0	—	—	9 ³	7700	2600	90	—	—	6F8G
6G6G	Pentode Power Amplifier	7S	Htr.	6.3	0.15	Class-A Amplifier	180 135	-9.0 -6.0	180 135	2.5 2	15 11.5	175000 170000	2300 2100	400 360	10000 19000	1.1 .6	6G6G
6H4GT	Diode Rectifier	5AF	Htr.	6.3	0.15	Detector	100	—	—	—	4.0	—	—	—	—	—	6H4GT
6H8G	Diode-Diode High- μ Pentode	8E	Htr.	6.3	0.3	Class-A Amplifier	250	-2	—	—	8.5	650000	2400	—	—	—	6H8G
6J8G	Triode Heptode	8H	Htr.	6.3	0.3	Converter	250	-3.0	100	2.8	1.2	—	Anode-grid (No. 2) 250 volts max. through 20,000-ohm dropping resistor, 5 ma.	—	—	—	6J8G
6K5G	High- μ Triode	5U	Htr.	6.3	0.3	Class-A Amplifier	100 250	-1.5 -3.0	—	—	0.35 1.1	78000 50000	900 1400	70 70	—	—	6K5G
6K6G	Pentode Power Amplifier	7S	Htr.	6.3	0.4	Class-A Amplifier	135 250	-5.0 -9.0	—	—	3.5 8.0	—	1500 1900	17	—	—	6K6G
6L5G	Triode Amplifier	6Q	Htr.	6.3	0.15	Class-A Amplifier	250	-6	250	4.0	36	—	9500	—	7000	—	6L5G
6M6G	Power Amplifier Pentode	7S	Htr.	6.3	1.2	Class-A Amplifier	250	-2.5	125	2.8	10.5	900000	3400	—	—	4.4	6M6G
6M7G	Triple-Grid Amplifier	7R	Htr.	6.3	0.3	R. F. Amplifier	100	—	—	—	0.5	91000	1100	—	—	—	6M7G
6M8GT	Diode Triode Pentode	8AU	Htr.	6.3	0.6	Pentode Amplifier	100	-3	100	—	8.5	200000	1900	—	—	—	6M8GT
6N6G	Direct-Coupled Amplifier	7W	Htr.	6.3	0.8	Power Amplifier	250	-13.5	—	—	5.0	—	1450	13.8	—	—	6N6G
6P5G	Triode Amplifier	6Q	Htr.	6.3	0.3	Class-A Amplifier	250	—	—	—	—	—	—	—	—	—	6P5G
6P7G	Triode-Pentode	7U	Htr.	6.3	0.3	Class-A Amplifier	250	—	—	—	—	—	—	—	—	—	6P7G
6P8G	Triode-Hexode Converter	8K	Htr.	6.3	0.8	Osc.-Mixer	250	-2	75	1.4	1.5	—	—	—	—	—	6P8G

TABLE II — 6.3-VOLT GLASS TUBES WITH OCTAL BASES — Continued

Type	Name	Socket Connections ¹	Cathode	Fil. or Heater		Use	Plate Supply Volts	Grid Bias	Screen Volts	Screen Current Ma.	Plate Current Ma.	Plate Resistance, Ohms	Transconductance Micromhos	Amp. Factor	Load Resistance Ohms	Power Output Watts	Type
				Volts	Amps.												
6C6G	Diode-Triode	6Y	Htr.	6.3	0.15	Class-A Amplifier	250	- 3.0	—	1.2	—	1050	65	—	—	6C6G	
6R6G	Pentode Amplifier	6AA	Htr.	6.3	0.3	Class-A Amplifier	250	- 3.0	100	1.7	7.0	1450	1160	—	—	6R6G	
6S6GT	Triple-Grid Variable- μ	5AK	Htr.	6.3	0.45	R.F. Amplifier	250	- 2	100	3.0	13	350000	4000	—	—	6S6GT	
6SD7GT	Triple-Grid Semi-Variable- μ	8N	Htr.	6.3	0.3	R.F. Amplifier	250	- 2	100	1.9	6.0	1000000	3600	—	—	6SD7GT	
6SE7GT	Triple-Grid Amplifier	8N	Htr.	6.3	0.3	R.F. Amplifier	250	- 1.5	100	1.5	4.5	1100000	3400	—	—	6SE7GT	
6T6GM	Triple-Grid Amplifier	6Z	Htr.	6.3	0.45	R.F. Amplifier	250	- 1	100	2.0	10	1000000	5500	—	—	6T6GM	
6U6GT	Beam Power Amplifier	7AC	Htr.	6.3	0.75	Class-A Amplifier	200	- 14	135	3.0	56	20000	—	3000	5.5	6U6GT	
6U7G	Triple Grid Variable- μ	7R	Htr.	6.3	0.3	R.F. Amplifier	—	—	—	—	—	—	—	—	—	6U7G	
6V7G	Duplex Diode-Triode	7V	Htr.	6.3	0.3	Detector-Amplifier	—	—	—	—	—	—	—	—	—	6V7G	
6W6GT	Beam Power Amplifier	7AC	Htr.	6.3	1.25	Class-A Amplifier	135	- 9.5	135	12	61	—	9000	215	2000	3.3	6W6GT
6X7G	Triode-Grid Det. Amp.	7R	Htr.	6.3	0.15	Class-A Amplifier	250	- 3.0	100	2	0.5	1500000	1925	1850	—	—	6X7G
6X6G	Electron-Ray Tube	7AL	Htr.	6.3	0.3	Indicator Tube	250	—	—	—	—	—	—	—	—	—	6X6G
6Y6G	Beam Power Amplifier	7AC	Htr.	6.3	1.25	Class-A Amplifier	135	- 13.5	135	3	60	—	7000	—	2000	3.6	6Y6G
6Y7G	Twin Triode Amplifier	8B	Htr.	6.3	0.3	Class-B Amplifier	—	—	—	—	—	—	—	—	—	—	6Y7G
6Z7G	Twin Triode Amplifier	8B	Htr.	6.3	0.3	Class-B Amplifier	180	0	—	—	8.4 ²	—	—	—	19000	4.2	6Z7G
1223	Pentode Amplifier	7R	Htr.	6.3	0.3	Class-A Amplifier	135	0	—	—	6 ²	—	—	—	9000	2.5	1223
1931	Pentode Amplifier	8V	Htr.	6.3	0.45	Class-A Amplifier	300	- 2.5 ¹	150	2.5	10	700000	5500	3850	—	—	1931
7000	Low-Noise Amplifier	7R	Htr.	6.3	0.3	Class-A Amplifier	—	—	—	—	—	—	—	—	—	—	7000

¹ Refer to Receiving Tube Diagrams. No connection to Pin No. 1.

² No-signal value for 2 tubes.

³ Per plate.

⁴ Plate No. 1, remote cut-off.

⁵ Plate No. 2, sharp cut-off.

⁶ Through 200-ohm cathode resistor.

⁷ Common plate.

⁸ Metal-sprayed glass envelope.

TABLE III — 7-VOLT LOKTAL-BASE TUBES

Type	Name	Socket Connections	Cathode	Heater		Use	Plate Supply Volts	Grid Bias	Screen Volts	Screen ¹ Current Ma.	Plate ¹ Current Ma.	Plate Resistance, Ohms	Transconductance Micromhos	Amp. Factor	Load Resistance Ohms	Power Output Watts	Type
				Volts	Amps.												
7A4	Triode Amplifier	5-AC	Htr.	7.0	0.32	Class-A Amplifier	250	- 8	—	—	9	7700	2600	20	—	—	7A
7A5	Beam Power Amplifier	6-AT	Htr.	7.0	0.75	Class-A Amplifier	125	- 9	195	3.2/8	37.5/40	17000	6100	—	2700	1.9	7A5
7A6	Twin Diode	7-AJ	Htr.	7.0	0.16	Rectifier	—	—	—	—	—	—	—	—	—	—	7A6
7A7	Remote Cut-off Pentode	8-V	Htr.	7.0	0.32	R.F. Amplifier	250	- 3	100	2.0	8.6	800000	2000	1600	—	—	7A7
7A8	Multigridd Converter	8-U	Htr.	7.0	0.16	Osc.-Mixer	250	- 3	100	3.1	3.0	50000	—	—	—	—	7A8
7B4	High- μ Triode	5-AC	Htr.	7.0	0.32	Class-A Amplifier	250	- 2	—	—	0.9	66000	1500	100	—	—	7B4
7B5	Pentode Amplifier	6-AE	Htr.	7.0	0.43	Class-A Amplifier	250	- 18	250	5.5/10	32/33	68000	2300	—	7600	3.4	7B5
7B6	Duo-diode Triode	8-W	Htr.	7.0	0.32	Class-A Amplifier	250	- 2	—	—	1.0	91000	1100	100	—	—	7B6
7B7	Remote Cut-off Pentode	8-V	Htr.	7.0	0.16	R.F. Amplifier	250	- 3	100	2.0	8.5	700060	1700	1200	—	—	7B7
7B8	Pentagrid Converter	8-X	Htr.	7.0	0.32	Osc.-Mixer	250	- 3	100	2.7	3.5	360000	—	—	—	—	7B8
7C5	Tetode Amplifier	6-AA	Htr.	7.0	0.48	Class-A Amplifier	250	- 12.5	250	4.5/7	45/47	52000	4100	—	5000	4.5	7C5
7C6	Duo-diode Triode	8-W	Htr.	7.0	0.16	Class-A Amplifier	250	- 1	—	—	—	100000	1000	100	—	—	7C6
7C7	Pentode Amplifier	8-V	Htr.	7.0	0.16	R.F. Amplifier	250	- 3	100	0.5	2.0	2 meg.	1300	—	—	—	7C7

¹ Refer to Receiving Tube Diagrams. No connection to Pin No. 1.

² No-signal value for 2 tubes.

³ Per plate.

⁴ Plate No. 1, remote cut-off.

⁵ Plate No. 2, sharp cut-off.

⁶ Through 200-ohm cathode resistor.

⁷ Common plate.

⁸ Metal-sprayed glass envelope.

TABLE III — 7-VOLT LOKTAL-BASE TUBES — Continued

Type	Name	Socket Connections	Cathode	Heater*		Use	Plate Supply Volts	Grid Bias	Screen Volts	Screen ¹ Current Ma.	Plate ¹ Current Ma.	Plate Resistance, Ohms	Transconductance, Micromhos	Amp. Factor	Load Resistance, Ohms	Power Output Watts	Type
				Volts	Amps.												
7D7	Triode-Hexode Converter	8 AR	Htr.	7.0	0.48	Osc.-Mixer	250	-3	—	—	Triode Plate (No. 3) 150 v. 3.5 ma.	1900	16	—	—	7D7	
7E6	Duo-Diode Triode	8 W	Htr.	7.0	0.32	Class-A Amplifier	250	-9	—	9.5	8500	1300	—	—	—	7E6	
7E7	Duo-diode Pentode	8-W	Htr.	7.0	0.32	Class-A Amplifier	250	-3	100	1.6	700000	1600	70	—	—	7E7	
7F7	Twin Triode	8-AC	Htr.	7.0	0.32	Class-A Amplifier ³	250	-2	—	—	2.3	44000	—	—	—	7F7	
7G7	Triple-Grid Amplifier	8 V	Htr.	7.0	0.48	Class-A Amplifier	250	-2	100	2.0	6.0	800000	4500	—	—	1232	
7H7	Triple-Grid Semi-Variable- μ	8 V	Htr.	7.0	0.32	R.F. Amplifier	250	-2.5	150	2.5	9.0	1000000	3500	—	—	7H7	
7J7	Triode-Hexode Converter	8 AR	Htr.	7.0	0.32	Osc.-Mixer	250	-3	100	2.9	1.3	Triode Plate 250 v. Max. ²	—	—	—	7J7	
7L7	Triple-Grid Amplifier	8 V	Htr.	7.0	0.32	Class-A Amplifier	250	-1.5	100	1.5	4.5	100000	3100	Cathode Resistor: 250 ohms	—	7L7	
7N7	Twin Triode	8-AC	Htr.	7.0	0.6	Class-A Amplifier ³	250	-8	—	—	9.0	2600	90	—	—	7N7	
7Q7	Pentagrid Converter	8-AL	Htr.	7.0	0.32	Osc.-Mixer	250	0	100	8	3.4	800000	—	Grid No. 1 resistor 20000 ohms	—	7Q7	

* Maximum rating, corresponding to 130-volt line condition; normal rating is 6.3 v. for 117-v. line.

¹ Values to left of diagonal lines are for "no-signal" condition; values to right are "with signal."

² Applied through 2000-ohm drooping resistor.

³ Each triode.

TABLE IV — 6.3-VOLT GLASS RECEIVING TUBES

Type	Name	Base ¹	Socket Connections ¹	Cathode	Fil. or Heater		Use	Plate Supply Volts	Grid Bias	Screen Volts	Screen Current Ma.	Plate Current Ma.	Plate Resistance, Ohms	Transconductance, Micromhos	Amp. Factor	Load Resistance, Ohms	Power Output Watts	Type
					Volts	Amps.												
6A3	Triode Power Amplifier	4-pin M.	4D	Fil.	6.3	1.0	Class-A Amplifier Push-Pull Amplifier	250	-45	—	—	60	800	2250	4.2	2500	3.5	6A3
6A4 ³	Pentode Power Amplifier	5-pin M.	5B	Fil.	6.3	0.3	Class-A Amplifier	300	-62 Note 10	Fixed Bias	40	40	Power output for 2 tubes load plate-to-plate	—	—	3000	15	6A3
6A6	Twin Triode Amplifier	7-pin M.	7B	Htr.	6.3	0.8	Class-B Amplifier	180	-12.0	180	3.9	22.0	45500	2200	100	8000	1.40	6A4
6A7	Pentagrid Converter	7-pin S.	7C	Htr.	6.3	0.3	Converter	250	0	—	—	—	—	—	—	8000	8.0	6A6
6AB5	Electron-Ray Tube	6-pin S.	6R	Htr.	6.3	0.15	Indicator Tube	135	0	—	—	0.5	—	—	—	10000	10.0	6A7
6B5	Direct-Coupled Power Amplifier	6-pin M.	6D	Htr.	6.3	0.8	Class-A Amplifier Push-Pull Amplifier	300	0	—	—	4.5	—	—	—	—	—	6AB5
6B7	Duplex-Diode Pentode	7-pin S.	7D	Htr.	6.3	0.3	Pentode R.F. Amplifier	400	-13	—	—	4.0	—	—	—	7000	4.0	6B5
6C6	Triple-Grid Amplifier	6-pin S.	6F	Htr.	6.3	0.3	R.F. Amplifier	250	-3.0	125	2.3	9.0	650000	1125	730	—	6B7	
6C7	Duplex Diode Triode	7-pin S.	7G	Htr.	6.3	0.3	Pentode A.-F. Amplifier	250	-4.5	50	—	0.65	—	—	—	—	6C6	
6D6	Triple-Grid Variable- μ Amplifier	6-pin S.	6F	Htr.	6.3	0.3	Class-A Amplifier	250	-3.0	100	0.5	2.0	1.5 mes.	1225	1500	—	6C7	
6D7	Triple-Grid Amp.	7-pin S.	7H	Htr.	6.3	0.3	Mixer	250	-3.0	100	2.0	8.2	800000	1600	1280	—	6D6	
6E5	Electron-Ray Tube	6-pin S.	6R	Htr.	6.3	0.3	Indicator Tube	250	-10.0	100	—	—	—	—	—	—	—	6D7
6E6	Twin Triode Amplifier	7-pin M.	7B	Htr.	6.3	0.6	Class-A Amplifier	250	0	—	—	0.25	—	—	—	—	—	6E5
6E7	Triple-Grid Variable- μ	7-pin S.	7H	Htr.	6.3	0.3	R.F. Amplifier	250	-27.5	Per plate — 18.0	—	3500	1700	6.0	14000	1.6	—	6E6
6F7	Triode Pentode	7-pin S.	7E	Htr.	6.3	0.3	Triode Unit Amplifier Pentode Unit Amplifier Pentode Unit Mixer	100	-3.0	—	—	3.5	16000	500	8	—	—	6E7

Oscillator peak volts = 7.0

Target Current 4 ma.

Oscillator peak volts = 7.0

Characteristics same as 6U7G — Table II

Oscillator peak volts = 7.0

Oscillator peak volts = 7.0

TABLE IV—6.3-VOLT GLASS RECEIVING TUBES—Continued

Type	Name	Base ¹	Socket Connections	Cathode	Fill. or Heater	Use	Plate Supply Volts	Grid Bias	Screen Volts	Screen Current Ma.	Plate Current Ma.	Plate Resistance, Ohms	Transconductance, Micromhos	Amp. Factor	Load Resistance, Ohms	Power Output, Watts	Type
6G5/6U5	Electron-Ray Tube	6-pin S.	6R	Htr.	6.3 0.3	Indicator Tube	250	Cut-off	90	1.7	0.24	—	Target Current 4 ma.	—	—	—	6G5/6U5
6H5	Electron-Ray Tube	6-pin S.	6R	Htr.	6.3 0.3	Indicator Tube	180	Cut-off	90	1.7	0.5	—	Target Current 2 ma.	—	—	—	6H5
6N5	Electron-Ray Tube	6-pin S.	6R	Htr.	6.3 0.15	Indicator Tube	250	Cut-off	90	1.7	0.24	—	Target Current 4 ma.	—	—	—	6N5
6T5	Electron-Ray Tube	6-pin S.	6R	Htr.	6.3 0.3	Indicator Tube	250	Cut-off	90	1.7	0.24	—	Target Current 4 ma.	—	—	—	6T5
36	Tetrode R.F. Amplifier	5-pin S.	5E	Htr.	6.3 0.3	R.F. Amplifier	250	-3.0	90	1.7	3.2	550000	1080	595	—	—	36
37	Triode Detector Amplifier	5-pin S.	5A	Htr.	6.3 0.3	Class-A Amplifier	250	-18.0	90	1.7	7.5	8400	1100	9.2	—	—	37
38	Pentode Power Amplifier	5-pin S.	5F	Htr.	6.3 0.3	Class-A Amplifier	250	-25.0	250	3.8	22.0	100000	1900	190	10000	2.50	38
39	Variable ² R.F. Amplifier	5-pin S.	5F	Htr.	6.3 0.3	Screen-Grid R.F. Amplifier	250	3.0 min.	90	1.6	5.6	375000	960	360	—	—	39
44	Pentode	5-pin S.	5F	Htr.	6.3 0.3	Class-A Amplifier	250	-18.0	250	5.5	32.0	68000	2200	150	7600	3.40	44
41	Pentode Power Amplifier	6-pin S.	6B	Htr.	6.3 0.4	Class-A Amplifier	250	-16.5	250	6.5	34.0	100000	2200	220	7000	3.0	41
42	Pentode Power Amplifier	6-pin M.	6B	Htr.	6.3 0.7	Class-A Amplifier	250	-1.35	250	6.5	34.0	100000	2200	220	7000	3.0	42
75	Duplex-Diode Triode	6-pin S.	6G	Htr.	6.3 0.3	Triode Amplifier	250	-13.5	—	—	0.4	91000	1100	100	—	—	75
76	Triode Detector Amplifier	5-pin S.	5A	Htr.	6.3 0.3	Class-A Amplifier	250	-13.5	—	—	5.0	9500	1450	13.8	—	—	76
77	Triple-Grid Detector	6-pin S.	6F	Htr.	6.3 0.3	Bias Detector	250	-30.0	—	—	—	Plate current to be adjusted to 0.2 ma. with no signal				77	
78	Triple-Grid Variable ³	6-pin S.	6F	Htr.	6.3 0.3	R.F. Amplifier	250	-3.0	100	0.5	2.3	1500000	1250	1500	—	—	78
79	Twin Triode Amplifier	6-pin S.	6H	Htr.	6.3 0.6	R.F. Amplifier	250	-3.0	100	1.7	7.0	800000	1450	1160	—	—	79
85	Duplex-Diode Triode	6-pin S.	6G	Htr.	6.3 0.3	Class-B Amplifier	180	0	—	—	—	Power output is for one tube at stated load, plate-to-plate				85	
85AS	Duplex-Diode Triode	6-pin S.	6G	Htr.	6.3 0.3	Class-A Amplifier	250	-9.0	—	—	8.0	7500	1100	8.3	20000	0.350	85
89	Triple-Grid Power Amplifier	6-pin S.	6F	Htr.	6.3 0.4	Triode Amplifier ⁴	250	-9	—	—	5.5	—	1250	20	—	—	85 AS
1921	Triple-Grid Amplifier	6-pin S.	6F	Htr.	6.3 0.3	Class-A Amplifier ⁵	250	-31.0	—	—	32.0	9600	1800	4.7	5500	0.900	1921
1603	Triple-Grid Amplifier	6-pin M.	6F	Htr.	6.3 0.3	Pentode Amplifier ⁷	250	-25.0	250	5.5	32.0	70000	1800	125	6750	3.40	1603
7700	Triple-Grid Amplifier	6-pin S.	6F	Htr.	6.3 0.3	Class-B Triode Amplifier ⁸	250	0	—	—	—	Power output is for 2 tubes at stated load, plate-to-plate				7700	
RK100	Mercury-vapor Triode	6-pin M.	6A	Htr.	6.3 0.6	Class-A Amplifier ⁹	100	-2.5	—	—	—	Characteristics same as 6C6				RK100	

¹ Refer to Receiving Tube Diagram.
² Suppressor grid, connected to cathode inside tube, not shown on above diagram.
³ Also known as Type LA.
⁴ S.—small; M.—medium.
⁵ Current to input plate (P).
⁶ Grids Nos. 2 and 3, connected to plate.
⁷ Grid No. 2, screen; grid No. 3, suppressor.
⁸ Grids Nos. 1 and 2 tied together; grid No. 3 connected to plate.
⁹ Low noise, non-microphonic, tubes.
¹⁰ Cathode Resistor 780 ohms.

TABLE V — 2.5-VOLT RECEIVING TUBES

Type	Name	Base ³	Socket Connections ¹	Cathode	Fil. or Heater		Use	Plate Supply Volts	Grid Bias	Screen Volts	Screen Current Ma.	Plate Current Ma.	Plate Resistance, Ohms	Transconductance Micromhos	Amp. Factor	Load Resistance Ohms	Power Output Watts	Type	
					Volts	Amps													
2A3	Triode Power Amplifier	4-pin M.	4D	Fil.	2.5	2.5	Class-A Amplifier	250	-24.0	—	40.0	5150	3500	18.0	5000	4.0	2A3		
2A5	Pentode Power Amplifier	6-pin M.	6B	Htr.	2.5	1.75	Class-A Amplifier	250	-3.0	90	1.7	4.0	600000	1050	630	—	2A5		
2A6	Duplex-Diode Triode	6-pin S.	6G	Htr.	2.5	0.8	Class-A Amp.	250	-21.0	—	—	5.2	9250	975	9.0	—	2A6		
2A7	Pentagrid Converter	7-pin S.	7C	Htr.	2.5	0.8	Osc.-Mixer	250	-30.0	—	—	—	—	—	—	—	2A7		
2B6	Special Power Amplifier	7-pin M.	7J	Htr.	2.5	2.95	Amplifier	250	0	—	—	—	—	—	—	—	2B6		
2B7	Duplex-Diode Pentode	7-pin S.	7D	Htr.	2.5	0.8	Pentode Amplifier	250	-16.5	250	6.0	31.0	60000	2500	150	7000	2.7	47	
2E5	Electron-Ray Tube	6-pin S.	6R	Htr.	2.5	0.8	Indicator Tube	250	-5.0	20	—	—	—	—	—	—	—	27	
24-A	Tetrode R.F. Amplifier	5-pin M.	5E	Htr.	2.5	1.75	Screen-Grid R.F. Amp.	250	-3.0	90	2.5	6.5	400000	1050	480	—	—	35	
27	Triode Detector-Amplifier	5-pin M.	5A	Htr.	2.5	1.75	Class-A Amplifier	250	-30.0	—	—	—	—	—	—	—	—	45	
35	Variable- μ Amplifier	5-pin M.	5E	Htr.	2.5	1.75	Screen-Grid R.F. Amp.	250	-3.0	90	2.5	6.5	400000	1050	480	—	—	46	
45	Triode Power Amplifier	4-pin M.	4D	Fil.	2.5	1.5	Class-A Amplifier	250	-56.0	—	—	36.0	1700	9050	3.5	4600	2.00	58	
46	Dual-Grid Power Amplifier	5-pin M.	5C	Fil.	2.5	1.75	Class-A Amplifier ¹	250	-33.0	—	—	92.0	9380	3500	5.6	6400	1.25	59	
47	Pentode Power Amplifier	5-pin M.	5B	Fil.	2.5	1.75	Class-B Amplifier ²	400	0	—	—	—	—	—	—	—	—	59	
53	Twin Triode Amplifier	7-pin M.	7B	Htr.	2.5	2.0	Class-B Amplifier	250	-3.0	100	0.5	2.0	1.5 meg.	1925	1500	—	—	53	
55	Duplex-Diode Triode	6-pin S.	6G	Htr.	2.5	1.0	Class-A Amplifier	250	-3.0	100	2.0	8.2	800000	1600	1280	—	—	55	
56	Triode Amplifier-Detector	5-pin S.	5A	Htr.	2.5	1.0	Class-A Amplifier	250	-28.0	—	—	26.0	9300	2600	6.0	5000	1.95	58	
57	Triple-Grid Amplifier	6-pin S.	6F	Htr.	2.5	1.0	R.F. Amplifier	250	-18.0	250	9.0	35.0	40000	2500	100	6000	3.0	59	
58	Triple-Grid Variable- μ	6-pin S.	6F	Htr.	2.5	1.0	Screen-Grid R.F. Amp.	400	0	—	—	—	—	—	—	—	—	59	
59	Triple-Grid Power Amplifier	7-pin M.	7A	Htr.	2.5	2.0	Class-A Pentode ⁷	250	-18.0	250	9.0	35.0	40000	2500	100	6000	3.0	59	
RK15	Triode Power Amplifier	4-pin M.	4D ²	Fil.	2.5	1.75	Class-B Triode ⁸	400	—	—	—	—	—	—	—	—	—	—	59
RK16	Triode Power Amplifier	5-pin M.	5A	Htr.	2.5	2.0	Class-A Triode	250	-3.0	100	2.0	8.2	800000	1600	1280	—	—	58	
RK17	Pentode Power Amplifier	5-pin M.	5F	Htr.	2.5	2.0	Class-A Triode	250	-18.0	250	9.0	35.0	40000	2500	100	6000	3.0	59	

¹ Refer to Receiving Tube Diagrams.
² Grid No. 2 tied to plate.
³ Grid Nos. 1 and 2 tied together.
⁴ S — small; M — medium.
⁵ Grid No. 2, screen; grid No. 3, suppressor.
⁶ Grids Nos. 1 and 2 tied together; grid No. 3 connected to plate.
⁷ Grid No. 2, screen; grid No. 3, suppressor.
⁸ Grids Nos. 1 and 2 tied together; grid No. 3 connected to plate.

TABLE VI — 2.0-VOLT BATTERY RECEIVING TUBES

Type	Name	Base ²	Socket Connections ¹	Cathode	Fil. or Heater		Use	Plate Supply Volts	Grid Bias	Screen Volts	Screen Current Ma.	Plate Current Ma.	Plate Resistance, Ohms	Transconductance Micromhos	Amp. Factor	Load Resistance Ohms	Power Output Watts	Type
					Volts	Amps.												
1A4P	Variable- μ Pentode	4-pin S.	4M	Fil.	2.0	0.06	R.F. Amplifier	180	-3.0	67.5	0.8	2.3	1000000	750	750	—	—	1A4P
1A4T	Variable- μ Tetrode	4-pin S.	4K	Fil.	2.0	0.06	R.F. Amplifier	180	-3	67.5	0.7	2.3	960000	750	750	—	—	1A4T
1A6	Pentagrid Converter	6-pin S.	6L	Fil.	2.0	0.06	Converter	180	-3.0	67.5	2.4	1.3	500000	Anode grid (No. 2) 180 max. volts	—	—	1A6	
1B4P/951	Pentode R.F. Amplifier	4-pin S.	4M	Fil.	2.0	0.06	R.F. Amplifier	180	-3.0	67.5	0.6	1.7	1500000	650	1000	—	—	1B4P/951

¹ Refer to Receiving Tube Diagrams.
² Grid No. 2 tied to plate.
³ Grid Nos. 1 and 2 tied together.
⁴ S — small; M — medium.
⁵ Grid No. 2, screen; grid No. 3, suppressor.
⁶ Grids Nos. 1 and 2 tied together; grid No. 3 connected to plate.

TABLE VI — 2.0-VOLT BATTERY RECEIVING TUBES — Continued

Type	Name	Base ²	Socket Connections	Cathode	Fil. or Heater		Use	Plate Supply Volts	Grid Bias	Screen Volts	Screen Current Ma.	Screen Current Ma.	Plate Current Ma.	Plate Resistance, Ohms	Transcon-ductance Micromhos	Amp. Factor	Load Resistance Ohms	Power Output Watts	Type
					Volts	Amps													
1B5/25S	Duplex-Diode Triode	6-pin S.	6M	Fil.	2.0	0.06	Triode Class-A Amplifier	135	- 3.0	—	—	—	0.8	35000	575	20	—	1.4	1B5/25S
1C6	Pentagrid Converter	6-pin S.	6L	Fil.	2.0	0.12	Converter	180	- 3.0	67.5	2.0	1.5	750000	Anode grid (No. 2) 135 max. volts	—	—	—	—	1C6
1F4	Pentode Power Amplifier	5-pin M.	5K	Fil.	2.0	0.12	Class-A Amplifier	135	- 4.5	135	2.6	8	200000	1700	340	16000	0.34	1F4	
1F6	Duplex-Diode Pentode	6-pin S.	6W	Fil.	2.0	0.6	R.F. Amplifier	180	- 1.5	67.5	0.6	—	—	1000000	650	650	—	1F6	
							A.F. Amplifier	135	- 1.0	135	—	—	—	Plate 0.25 megohm Screen 1.0 megohm	—	—	Amp. = 48	—	
15	R.F. Pentode Amplifier-Oscillator	5-pin S.	5F	Htr.	2.0	0.22	R.F. Amplifier	135	- 1.5	67.5	0.3	1.85	800000	750	600	—	—	—	15
19	Twin-Triode Amplifier	6-pin S.	6C	Fil.	2.0	0.26	Class-B Amplifier	67.5	0	—	—	—	—	630000	710	450	—	—	19
30	Triode Detector Amplifier	4-pin S.	4D	Fil.	2.0	0.06	Class-A Amplifier	135	- 13.5	—	—	—	—	Load plate-to-plate	—	—	10000	2.1	30
31	Triode Power Amplifier	4-pin S.	4D	Fil.	2.0	0.13	Class-A Amplifier	180	- 30.0	—	—	3.1	10300	900	9.3	—	—	—	31
32	Tetrode R.F. Amplifier	4-pin M.	4K	Fil.	2.0	0.06	R.F. Amplifier	180	- 3.0	67.5	0.4	1.7	1900000	650	780	5700	0.375	32	
33	Pentode Power Amplifier	5-pin M.	5K	Fil.	2.0	0.26	Class-A Amplifier	180	- 18.0	180	5.0	22.0	55000	1700	90	6000	1.4	33	
34	Variable- μ Pentode	4-pin M.	4M	Fil.	2.0	0.06	R.F. Amplifier	180	- 3.0	67.5	1.0	2.8	1000000	620	620	—	—	—	34
49	Dual-Grid Power Amplifier	5-pin M.	5C	Fil.	2.0	0.12	Class-A Amplifier ¹	135	- 20.0	—	—	6.0	4175	1195	4.7	11000	0.17	49	
840	R.F. Pentode	5-pin S.	5J	Fil.	2.0	0.130	Class-B Amplifier ¹	180	0	—	—	—	—	Power output for 2 tubes at	—	—	—	—	840
950	Pentode Power Amplifier	5-pin M.	5B	Fil.	2.0	0.12	Class-A Amplifier	135	- 16.5	1.35	2.0	7.0	100000	1000	100	13500	0.45	950	
RK24	Triode Amplifier	4-pin M.	4D	Fil.	2.0	0.12	Class-A Amplifier	180	- 13.5	—	—	8.0	5000	1600	8.0	12000	0.25	RK24	

¹ See Receiving Tube Diagrams.

² S.—small, M.—medium.

³ Grid No. 2 tied to plate.

⁴ Grids Nos. 1 and 2 tied together.

TABLE VII — 2.0-VOLT BATTERY TUBES WITH OCTAL BASES

Type	Name	Socket Connections	Cathode	Fil. or Heater		Use	Plate Supply Volts	Grid Bias	Screen Volts	Screen Current Ma.	Plate Current Ma.	Plate Resistance, Ohms	Transcon-ductance Micromhos	Amp. Factor	Load Resistance Ohms	Power Output Watts	Type
				Volts	Amps												
1C7G	Pentagrid Converter	7Z	Fil.	2.0	0.06	Converter	—	—	—	—	—	—	—	—	—	—	1C7G
1D5GP	Variable- μ R.F. Pentode	5Y	Fil.	2.0	0.06	R.F. Amplifier	—	—	—	—	—	—	—	—	—	—	1D5GP
1D7G	Pentagrid Converter	7Z	Fil.	2.0	0.06	Converter	—	—	—	—	—	—	—	—	—	—	1D7G
1E5GP	R.F. Amplifier Pentode	5Y	Fil.	2.0	0.06	R.F. Amplifier	—	—	—	—	—	—	—	—	—	—	1E5GP
1E7G	Double Pentode Power Amp.	8C	Fil.	2.0	0.24	Class-A Amplifier	135	- 7.5	135	2.0 ²	6.5 ¹	930000	1600	350	24000	0.65	1E7G
1F5G	Pentode Power Amplifier	6X	Fil.	2.0	0.12	Class-A Amplifier	—	—	—	—	—	—	—	—	—	—	1F5G
1F7GV	Duplex-Diode Pentode	7AD	Fil.	2.0	0.06	Detector-Amplifier	—	—	—	—	—	—	—	—	—	—	1F7GV
1G5G	Pentode Power Amplifier	6X	Fil.	2.0	0.12	Class-A Amplifier	135	13.5	135	2.5	8.7	1600000	1550	250	9000	0.55	1G5G
1H4G	Triode Amplifier	5S	Fil.	2.0	0.06	Detector-Amplifier	—	—	—	—	—	—	—	—	—	—	1H4G
1H6G	Duplex-Diode Triode	7AA	Fil.	2.0	0.06	Detector-Amplifier	—	—	—	—	—	—	—	—	—	—	1H6G
1J5G	Pentode Power Amplifier	6XA	Fil.	2.0	0.12	Class-A Amplifier	135	- 16.5	135	2.0	7.0	—	950	100	13500	0.45	1J5G
1J6G	Twin Triode	7AB	Fil.	2.0	0.24	Class-B Amplifier	—	—	—	—	—	—	—	—	—	—	1J6G

¹ Refer to Receiving Tube Diagrams.

² Total current for both sections, no signal.

TABLE VIII—1.5-VOLT FILAMENT DRY-CELL TUBES

See also Table X for Special 1.4-volt Tubes

Type	Name	Base	Socket Connections	Filament		Use	Plate Supply Volts	Grid Bias	Screen Volts	Screen Current Ma.	Plate Current Ma.	Plate Resistance, Ohms	Transconductance Micromhos	Amp. Factor	Load Resistance Ohms	Power Output Milliwatts	Type
				Volts	Amps.												
1A5G	Pentode Power Amplifier	7-pin O.	6X	1.4	0.05	Class-A Amplifier	85 ³	-4.5 ³	85	0.7	3.5	300000	800	240	95000	100	1A5G
1A7G	Pentagrid Converter	8-pin O.	7Z	1.4	0.05	Osc.-Mixer	90	0	45 ⁵	0.6	0.55	600000	Anode-grid volts 90			1A7G	
1B7G	Pentagrid Converter	6-pin O.	7Z	1.4	0.1	Osc.-Mixer	90	0	45	1.3	1.5	350000	Grid No. 1 resistor 300,000 ohms			1B7G	
1B8GT	Diode Triode Tetrode	8-pin O.	8AW	1.4	0.1	Triode Amplifier Tetrode Amplifier	90	-6.0	90	1.4	0.15	940000	975		14000	310	1B8GT
1C5G	Pentode Power Amplifier	7-pin O.	6X	1.4	0.10	Class-A Amplifier	83 ³	-7 ³	83	1.6	7.0	110000	1500	165	9000	300	1C5G
1D8GT	Diode Triode Pentode	8-pin O.	8AJ	1.4	0.1	Triode Amplifier Pentode Amplifier	90	-9.0	90	1.0	1.1		575	25			1D8GT
1E4G	Triode Amplifier	8-pin O.	5S ¹²	1.4	0.05	Class-A Amplifier	90	-3.0			4.5	11000	1325	14.5			1E4G
1G4G	Triode Amplifier	7-pin O.	5S	1.4	0.05	Class-A Amplifier	90	-6.0			2.3		825	8.8			1G4G
1G6G	Twin Triode	6-pin O.	7AB	1.4	0.1	Class-A Amplifier Class-B Amplifier	90	0			1.0	45000	675	30	12000	675	1G6G
1H5G	Diode High- μ Triode	7-pin O.	5Z	1.4	0.05	Class-A Amplifier	90	0			1.7 ⁵	240000	275	65			1H5G
1LA4	Pentode Power Amplifier	8-pin L.	5AD	1.4	0.05	Class-A Amplifier	90	0	45	0.6	0.55	Characteristics same as 1A5G					1LA4
1LB4	Pentagrid Converter	8-pin L.	7AK	1.4	0.05	Osc.-Mixer	90	-9	90	1.0	5.0	900000	925		12000	300	1LB4
1LB4GL	Pentode Power Amplifier	8-pin L.	5AD	1.4	0.05	Class-A Amplifier	90	0	67.5	2.2	0.4		Grid No. 4 67.5 v., No. 5 0 v.				1LB4GL
1LC5	Heptode Converter	8-pin L.	8AX	1.4	0.05	Osc.-Mixer	90	0	45	0.2	1.15	1500000	775				1LC5
1LC6	Triple-Grid Variable- μ	8-pin L.	7AO	1.4	0.05	R.F. Amplifier	90	0	35 ⁵	0.7	0.75		Anode Grid Volts 45				1LC6
1LD5	Pentagrid Converter	8-pin L.	7AK	1.4	0.05	Osc.-Mixer	90	0	45	0.1	0.6	950000	600				1LD5
1LE3	Diode Pentode	7-pin L.	6AX	1.4	0.05	Class-A Amplifier	90	0			4.5	11900	1300	14.5			1LE3
1LH4	Triode Amplifier	8-pin L.	4AA	1.4	0.05	Class-A Amplifier	90	-3			1.3	19000	760				1LH4
1LN5	Diode High- μ Triode	8-pin L.	5AG	1.4	0.05	Class-A Amplifier	90	0			0.15	240000	275	65			1LN5
1N5G	Triple-Grid Amplifier	8-pin L.	7AO	1.4	0.05	Class-A Amplifier	90	0	90	0.3	1.2	1500000	750				1N5G
1N6G	Pentode R.F. Amplifier	7-pin O.	5Y	1.4	0.05	Class-A Amplifier	90	0	90	0.3	1.2	1500000	750	1160			1N6G
1P5G	Diode-Power Pentode	6-pin O.	7AM	1.4	0.05	Class-A Amplifier	90	-4.5	90	0.6	3.1	300000	800		25000	100	1P5G
1Q5G	Triple-Grid Pentode	5-pin O.	5Y	1.4	0.05	R.F. Amplifier	90	0	90	0.7	2.3	800000	800	640			1Q5G
1R5	Tetrode Power Amplifier	5-pin O.	6AF	1.4	0.1	Class-A Amplifier	85	-5.0	85	1.2	7.2		1950		9000	260	1R5
1S4	Pentagrid Converter	7-pin B ¹⁰	7AT	1.4	0.05	Osc.-Mixer	90	-4.5	90	1.6	9.5	600000	2100		8000	65	1S4
1T4	Power Amplifier Pentode	7-pin B ¹⁰	7AV	1.4	0.10	Class-A Amplifier	45	-4.5	45	0.8	3.8	250000	1950		8000		1T4
1T5	Diode Pentode	7-pin B ¹⁰	6AU	1.4	0.05	Class-A Amplifier	45	0	45	0.3	1.2	500000	525				1T5
1T5GT	Triple-Grid Variable- μ	7-pin B ¹⁰	6AR	1.4	0.05	R.F. Amplifier	45	0	45	0.7	1.9	350000	700				1T5GT
CK501	Beam Power Amplifier	7-pin O.	6AF	1.4	0.05	Class-A Amplifier	90	-6.0	90	1.4	6.5		1150		14000	170	CK501
CK502	Pentode Voltage Amplifier	5-pin P ⁵	6X	1.25	0.033	Class-A Amplifier	30	0	30	0.06	0.28	1.0 meg.	325				CK502
CK503	Pentode Output Amplifier	7-pin O.	6X	1.25	0.033	Class-A Amplifier	45	-1.25	45	0.055	0.55	500000	400		60000	3	CK503
	Pentode Output Amplifier	5-pin P ⁵	6X	1.25	0.033	Class-A Amplifier	30	0	30	0.13	0.55	150000	600		20000	6 ⁷	CK503

TABLE VIII—1.5-VOLT FILAMENT DRY-CELL TUBES—Continued

Type	Name	Base	Socket Connections ¹	Filament		Use	Plate Supply Volts	Grid Bias	Screen Volts	Screen Current Ma.	Plate Current Ma.	Plate Resistance, Ohms	Trans-conductance Micromhos	Amp. Factor	Load Resistance Ohms	Power Output Mills watts	Type
				Volts	Amps.												
CK504	Pentode Output Amplifier	5-pin P ⁶ 7-pin O ⁶	6X	1.25	0.033	Class-A Amplifier	30	-1.25	30	0.09	0.4	500000	350	—	60000	3.7	CK504
CK505	Pentode Voltage Amplifier	5-pin P ⁶ 7-pin O ⁶	6X	0.625 ¹¹	0.03	Class-A Amplifier	30	0	30	0.07	0.17	1100000	140	—	—	—	CK505
HY113	Triode Amplifier	5-pin P ⁶	5K ⁸	1.4	0.07	Class-A Amplifier	45	-4.5	—	—	0.4	95000	950	6.3	40000	6.5	HY113
HY115	Pentode Voltage Amplifier	5-pin P ⁶	5K	1.4	0.07	Class-A Amplifier	45	-1.5	22.5	0.008	0.03	5.2 meg.	58	300	—	—	HY115
HY125	Pentode Power Amplifier	5-pin P ⁶	5K	1.4	0.07	Class-A Amplifier	90	-1.5	43	0.1	0.48	1.3 meg.	270	—	—	—	HY125
RK42	Triode Amplifier	4-pin S.	4D	1.5	0.6	Class-A Amplifier	45	-3.0	45	0.2	2.9	85000	310	355	50000	11.5	RK42
RK43	Twin Triode Amplifier	6-pin S.	6C	1.5	0.12	Twin Triode Amplifier	90	-7.5	90	0.5	2.6	420000	450	190	28000	90	RK43
Characteristics same as Type 30—Table VI																	

¹ Refer to Receiving Tube Diagrams.
² M—medium; S—small; O—octal; L—loktal.
³ Grid bias obtained from 90-volt "B" supply through self-biasing resistor.
⁴ Obtained from 90-volt supply through 70,000-ohm dropping resistor.
⁵ Pentube. Values to left of diagonal line for no-signal condition; values to right are with signal.
⁶ Special miniature 5-pin peanut base. Also available with small-shell octal base.
⁷ With 5-megohm grid resistor and 0.02- μ fd. grid coupling condenser.
⁸ No screen connection.
⁹ Through series resistor. Screen voltage must be at least 10 volts lower than oscillator anode.
¹⁰ Special 7-pin "button" base, miniature type.
¹¹ Two tubes connected in series for 1.4-volt operation.
¹² Internal shield connected to pin 1.

TABLE IX—HIGH-VOLTAGE HEATER TUBES

Type	Name	Base ³	Socket Connections ¹	Heater		Use	Plate Supply Volts	Grid Bias	Screen Volts	Screen Current Ma.	Plate Current Ma.	Plate Resistance, Ohms	Trans-conductance Micromhos	Amp. Factor	Load Resistance Ohms	Power Output Watts	Type
				Volts	Amps.												
12A5	Pentode Power Amplifier	7-pin M.	7F	12.6	0.3	Class-A Amplifier	100	-15	100	4.0	18	—	—	—	5000	2.8	12A5
12A6	Beam Power Amplifier	7-pin O.	7AC	6.3	0.6	Class-A Amplifier	180	-27	180	9.0	40	—	—	—	4500	9.7	12A6
12A7	Rectifier-Amplifier ⁵	7-pin M.	7K	12.6	0.5	Class-A Amplifier	250	-12.5	250	3.5	30	50000	3000	100	7500	2.5	12A7
12A8GT	Pentagrid Converter	8-pin O.	8A	12.6	0.15	Osc-Mixer	135	-13.5	135	2.5	9.0	109000	975	100	13500	0.55	12A8GT
12B6M ¹	Diode Triode	6-pin O.	6Y	12.6	0.15	Class-A Amplifier	250	-2.0	—	—	0.9	91000	1100	100	—	—	12B6M
12B7	Triple-Grid Variable- μ	8-pin L.	8Y	12.6	0.15	R.F. Amplifier	250	-3.0	100	2.4	9.2	—	1800	360	—	—	12B7
12B8GT	Trode-Pentode	8-pin O.	8T	12.6	0.3	Class-A Triode	100	-1	—	—	0.6	73000	1500	110	—	—	12B8GT
12C8	Duplex-Diode Pentode	8-pin O.	8E	12.6	0.15	Class-A Pentode	100	-3	100	2	8	170000	2100	360	—	—	12C8
12E5GT	Triode Amplifier	6-pin O.	6Q	12.6	0.15	Class-A Amplifier	250	-13.5	—	—	5.0	—	1450	13.8	—	—	12E5GT
12F5GT	Triode Amplifier	5-pin O.	5M	12.6	0.15	Class-A Amplifier	250	-3.0	—	—	—	—	58000	70	—	—	12F5GT
12G7G	Duplex-Diode Triode	7-pin O.	7V	12.5	0.15	Class-A Amplifier	250	-3.0	—	—	—	—	58000	70	—	—	12G7G
12J5GT	Triode Amplifier	6-pin O.	6Q	12.6	0.15	Class-A Amplifier	—	—	—	—	—	—	—	—	—	—	12J5GT
12J7GT	Pentode Voltage Amplifier	7-pin O.	7R	12.6	0.15	Class-A Amplifier	—	—	—	—	—	—	—	—	—	—	12J7GT
12K7GT	Remote Cut-off Pentode	7-pin O.	7R	12.6	0.15	R.F. Amplifier	—	—	—	—	—	—	—	—	—	—	12K7GT
12K8	Triode Hexode Converter	8-pin O.	8K	12.6	0.15	Osc-Mixer	—	—	—	—	—	—	—	—	—	—	12K8
12O7GT	Duplex-Diode Triode	7-pin O.	7V	12.6	0.15	Class-C Amplifier	—	—	—	—	—	—	—	—	—	—	12O7GT
12SA7	Pentagrid Converter	8-pin O.	8R	12.6	0.15	Osc-Mixer	—	—	—	—	—	—	—	—	—	—	12SA7
Characteristics same as 6A8—Table I																	
Characteristics same as 6B8—Table I																	
Characteristics same as 6F5—Table I																	
Characteristics same as 6J5—Table I																	
Characteristics same as 6J7—Table I																	
Characteristics same as 6K7—Table I																	
Characteristics same as 6K8—Table I																	
Characteristics same as 6O7—Table I																	
Characteristics same as 6SA7—Table I																	

¹ M—medium; S—small; O—octal; L—loktal.
² Grid bias obtained from 90-volt "B" supply through self-biasing resistor.
³ Obtained from 90-volt supply through 70,000-ohm dropping resistor.
⁴ Pentube. Values to left of diagonal line for no-signal condition; values to right are with signal.
⁵ Special miniature 5-pin peanut base. Also available with small-shell octal base.
⁶ Special 7-pin "button" base, miniature type.
⁷ With 5-megohm grid resistor and 0.02- μ fd. grid coupling condenser.
⁸ No screen connection.
⁹ Through series resistor. Screen voltage must be at least 10 volts lower than oscillator anode.
¹⁰ Special 7-pin "button" base, miniature type.
¹¹ Two tubes connected in series for 1.4-volt operation.
¹² Internal shield connected to pin 1.

TABLE IX — HIGH-VOLTAGE HEATER TUBES — Continued

Type	Name	Base ³	Socket Connections ¹	Heater		Use	Plate Supply Volts	Grid Bias	Screen Volts	Screen Current Ma.	Plate Current Ma.	Plate Resistance, Ohms	Transconductance, Micromhos	Amp. Factor	Load Resistance, Ohms	Power Output, Watts	Type
				Volts	Amps.												
19SC7	Twin Triode	8-pin O.	8S	12.6	0.15	Class-A Amplifier	—	—	—	—	—	—	—	—	—	—	19SC7
19SF5GT	High- μ Triode	6-pin O.	8P	12.6	0.15	Class-A Amplifier	—	—	—	—	—	—	—	—	—	—	19SF5GT
19S17	Pentode Voltage Amplifier	8-pin O.	8N	12.6	0.15	Class-A Amplifier	—	—	—	—	—	—	—	—	—	—	19S17
19SK7	Remote Cut-off Pentode	8-pin O.	8N	12.6	0.15	R.F. Amplifier	—	—	—	—	—	—	—	—	—	—	19SK7
19SQ7	Duplex-Diode Triode	8-pin O.	8Q	12.6	0.15	Class-A Amplifier	—	—	—	—	—	—	—	—	—	—	19SQ7
19SR7	Duplex-Diode Triode	8-pin O.	8Q	12.6	0.15	Class-A Amplifier	—	—	—	—	—	—	—	—	—	—	19SR7
14B6	Duplex-Diode High- μ Triode	8-pin L.	8W	14.0 ⁴	0.16	Class-A Amplifier	—	—	—	—	—	—	—	—	—	—	14B6
14J7	Triode-Hexode Converter	8-pin L.	8AR	14.0 ⁴	0.16	Osc.-Mixer	—	—	—	—	—	—	—	—	—	—	14J7
14Q7	Heptode Pentagrid Converter	8-pin L.	8AL	14.0 ⁴	0.16	Osc.-Mixer	—	—	—	—	—	—	—	—	—	—	14Q7
20J8GM ³	Triode Heptode Converter	8-pin O.	8H	20	0.15	Osc.-Mixer	250	-3.0	100	3.4	1.5	—	—	—	—	—	20J8GM
31A7	Triode Hexode Converter	8-pin L.	8AR	21	0.16	Osc.-Mixer	250	-3.0	100	2.8	1.3	—	—	—	—	—	31A7
25A6	Pentode Power Amplifier	7-pin O.	7S	25	0.3	Class-A Amplifier	150	-20	135	8	37	35000	9450	85	4000	9.0	25A6
25A7G	Rectifier-Amplifier ⁵	8-pin O.	8F	25	0.3	Class-A Amplifier	100	-15	100	4.0	30.5	50000	1800	90	4500	0.77	25A7G
25AC5G	Triode Power Amplifier	6-pin O.	6Q	25	0.3	Class-A Amplifier	110	+15	—	—	45	—	3800	58	3000	3.0	25AC5G
25B5	Direct-Coupled Triodes	6-pin S.	6D	25	0.3	Class-A Amplifier	110	0	110	7	45	11400	2200	25	2000	2.0	25B5
25B6G	Pentode Power Amplifier	7-pin O.	7S	25	0.3	Class-A Amplifier	95	-15	95	4	45	—	4000	—	2000	1.75	25B6G
25B8GT	Triode Pentode	8-pin O.	8T	25	0.15	Class-A Amplifier	—	—	—	—	—	—	—	—	—	—	25B8GT
25C6G	Beam Power Amplifier	7-pin O.	7AC	25	0.3	Class-A Amplifier	135	-13.5	135	3.5/11.5	58/60	9300	7000	—	2000	3.6	25C6G
25D8GT	Diode Triode Pentode	8-pin O.	8AF	25	0.15	Triode Amplifier Pentode Amplifier	100	-1.0	—	—	0.5	91000	1100	100	—	—	25D8GT
25L6	Beam Power Amplifier	7-pin O.	7AC	25	0.3	Class-A Amplifier	110	-8	110	3.5-10.5	45-48	10000	8000	80	3000	2.2	25L6
25N6G	Direct-Coupled Triodes	8-pin O.	8F	25	0.3	Class-A Amplifier	110	0	110	7	45	11400	2200	25	2000	2.0	25N6G
38L7GT	Diode-Beam Tetrode ⁵	8-pin O.	8F	32.5	0.3	Class-A Amplifier	110	-7.5	110	3	40	15000	6000	—	2500	1.5	38L7GT
35A5	Beam Power Amplifier	8-pin O.	6AA	35	0.16	Class-A Amplifier	110	-7.5	110	2.8	35	25000	5500	—	2500	1.4	35A5
35A5LT	Beam Power Amplifier	8-pin L.	6AT	35	0.15	Class-A Amplifier	110	-7.5	110	3/7	40/41	14000	5800	—	2500	1.5	35A5LT
35L6G	Beam Power Amplifier	7-pin O.	7AC	35	0.15	Class-A Amplifier	110	-7.5	110	3/7	40/41	13800	5800	—	2500	1.5	35L6G
50C6G	Beam Power Amplifier	7-pin O.	7AC	50	0.15	Class-A Amplifier	135	-13.5	135	3.5/11.5	58/60	9300	7000	—	2000	3.6	50C6G
50L6GT	Beam Power Amplifier	7-pin O.	7AC	50	0.15	Class-A Amplifier	110	-7.5	110	4/11	49/50	—	8200	82	2000	2.2	50L6GT
70A7GT	Diode-Beam Tetrode ⁵	8-pin O.	—	70	0.15	Class-A Amplifier	110	-7.5	110	3.0	40	—	5800	80	2500	1.5	70A7GT
70L7GT	Diode-Beam Tetrode ⁵	8-pin O.	8AA	70	0.15	Class-A Amplifier	110	-7.5	110	3/6	40/43	15000	7500	—	3000	1.8	70L7GT
117L7GT	Rectifier-Amplifier ⁵	8-pin O.	8AO	117	0.09	Class-A Amplifier	105	-5.5	105	4.0	45	20000	4000	—	4000	5.5	117L7GT
117M7GT	Rectifier-Amplifier ⁵	8-pin O.	8AO	117	0.09	Class-A Amplifier	100	-5.5	100	4.0	45	15000	6500	—	3000	1.0	117M7GT
117N7GT	Rectifier-Amplifier ⁵	8-pin O.	8AV	117	0.09	Class-A Amplifier	100	-6.0	100	5.0	57	16000	7000	—	3000	1.2	117N7GT
43	Pentode Power Amplifier	6-pin M.	6B	25.0	0.3	Class-A Amplifier	95	-15.0	95	4.0	30.0	45000	2000	90	4500	0.90	43
48	Tetrode Power Amplifier	6-pin M.	6A	30.0	0.4	Class-A Amplifier	96	-19.0	96	9.0	52.0	—	3800	—	1500	2.0	48

¹ Refer to Receiving Tube Diagrams.
² M. — medium; S. — small; O. — octal; L. — loktal.
³ Metal-sprayed glass envelope.
⁴ Maximum rating, corresponding to 130-volt line condition; normal rating is 12.6 v. for 117-v. line.
⁵ For rectifier data, see Table XIII.

TABLE X — MISCELLANEOUS RECEIVING TUBES

Type	Name	Base ²	Socket Connections	Cathode	Fil. or Heater		Use	Plate Supply Volts	Grid Bias	Screen Volts	Screen Current Ma.	Plate Current Ma.	Plate Resistance, Ohms	Transconductance Micromhos	Amp. Factor	Load Resistance Ohms	Power Output Watts	Type	
					Volts	Amps.													
00-A	Triode Detector	4-pin M.	4D	Fil.	5.0	0.25	Grid Leak Detector	45	—	—	—	1.5	30000	666	20	—	—	00-A	
01-A	Triode Detector Amplifier	4-pin M.	4D	Fil.	5.0	0.25	Class-A Amplifier	135	-9.0	—	—	3.0	10000	800	8.0	—	—	01-A	
3A8GT	Diode Triode Pentode	8-pin O.	8AS	Fil. ⁶	2.4	0.1	Class-A Triode	90	0	—	—	0.15	240000	275	65	—	—	3A8GT	
				Fil. ⁶	1.8	0.05	Class-A Pentode	90	0	90	0.3	1.2	600000	750	—	—	—	—	
3C5GT	Power Output Pentode	7-pin O.	7AQ	Fil. ⁶	1.4	0.1	Class-A Amplifier	90	-9.0	90	1.4	6.0	—	1550	—	—	0.24	3C5GT	
				Fil.	2.8	0.050	Class-A Amplifier	90	-9.0	90	1.8	9.0	110000	1600	—	—	0.26	3C5GT	
3LE4	Power Amplifier Pentode	8-pin L.	6BA	Fil.	2.8	0.1	Class-A Amplifier	90	-4.5	90	1.6	9.5	—	2100	—	—	0.30	3LE4	
3O5GT	Beam Power Amplifier	7-pin O.	7AP	Fil. ⁶	2.8	0.05	Class-A Amplifier	90	-4.5	90	1.0	7.5	—	1800	—	—	0.27	3O5GT	
10	Triode Power Amplifier	4-pin M.	4D	Fil.	7.5	1.25	Class-A Amplifier	425	-39.0	—	—	18.0	5000	1600	8.0	10900	1.6	10	
11/12	Triode Detector Amplifier	4-pin M.	4D	Fil.	1.1	0.25	Class-A Amplifier	135	-10.5	—	—	3.0	15000	440	6.6	—	—	11/12	
20	Triode Power Amplifier	4-pin S.	4D	Fil.	3.3	0.132	Class-A Amplifier	135	-22.5	—	—	6.5	6300	525	3.3	6500	0.110	20	
22	Tetrode R.F. Amplifier	4-pin M.	4K	Fil.	3.3	0.132	R.F. Amplifier	135	-1.5	67.5	1.3	3.7	325000	500	160	—	—	22	
26	Triode Amplifier	4-pin M.	4D	Fil.	1.5	1.05	Class-A Amplifier	180	-14.5	—	—	6.2	7300	1150	8.3	—	—	26	
40	Triode Voltage Amplifier	4-pin M.	4D	Fil.	5.0	0.25	Class-A Amplifier	180	-3.0	—	—	0.2	150000	300	30	—	—	40	
4A6G	Twin Triode Amplifier	8-pin O.	8L	Fil. ⁶	2.3	0.12	Class-B Amplifier	90	0	—	—	2.2	13300	1500	20	—	—	4A6G	
50	Triode Power Amplifier	4-pin M.	4D	Fil.	7.5	1.25	Class-A Amplifier	450	-84.0	—	—	55.0	1800	2100	3.8	4350	4.6	50	
71-A	Triode Power Amplifier	4-pin M.	4D	Fil.	5.0	0.25	Class-A Amplifier	180	-43.0	—	—	20.0	1750	1700	3.0	4800	0.790	71-A	
99	Triode Detector Amplifier	4-pin S.	4D	Fil.	3.3	0.063	Class-A Amplifier	90	-4.5	—	—	2.5	15500	425	6.6	—	—	99	
112A	Triode Detector Amplifier	4-pin M.	4D	Fil.	5.0	0.25	Class-A Amplifier	180	-13.5	—	—	7.7	4700	1800	8.5	—	—	112A	
188B/488B	Triode Amplifier	4-pin M.	4D	Fil.	5.0	1.25	Class-A Amplifier	250	-35	—	—	18	—	1500	5.0	—	—	188B/488B	
183/483	Power Triode	4-pin M.	4D	Fil.	5.0	1.25	Class-A Amplifier	250	60	—	—	25	18000	1800	3.2	4500	2.0	183/483	
257	Power Pentode	5-pin M.	5B	Fil.	5.0	0.30	Class-A Amplifier	110	21.5	110	7	20	41000	1350	55	6000	0.8	257	
485	Triode	4-pin S.	4D	Htr.	3.0	1.30	Class-A Amplifier	180	9.0	—	—	6.0	9300	1350	12.5	—	—	485	
864	Triode Amplifier	4-pin S.	4D	Fil.	1.1	0.25	Class-A Amplifier	90	-4.5	—	—	2.9	13500	610	8.2	—	—	864	
954 ⁷	Pentode Detector, Amplifier	Special	A ⁷	Htr.	6.3	0.15	Class-A Amplifier	250	3	100	0.7	2.0	1.5 megohms	1400	2000	—	—	—	954
							Bias Detector	250	6	100	—	—	—	—	—	—	—	—	—
935 ⁷	Triode Detector, Amplifier	Special	B ⁷	Htr.	6.3	0.16	Class-A Amplifier	180	-5	—	—	4.5	12500	2000	25	20000	0.135	935	
							Oscillator	180	-35	—	—	7	—	—	—	—	—	—	—
956 ⁷	Triple-Grid Variable- μ R.F. Amplifier	Special	A ⁷	Htr.	6.3	0.15	R.F. Amplifier	250	3	100	1.8	5.5	800000	1800	1440	—	—	—	956
							Mixer	250	-10	100	—	—	—	—	—	—	—	—	—
937 ⁷	Triode Det., Amp., Osc.	Special	C ⁷	Fil.	1.25	0.05	Class-A Amplifier	135	-5	—	—	2.0	24600	650	16	—	—	—	937
938 ⁷	Triode A.F. Amp., Osc.	Special	C ⁷	Fil.	1.25	0.1	Class-A Amplifier	135	-7.5	—	—	3.0	10000	1200	12	—	—	—	938
959 ⁷	Pentode Det., Amplifier	Special	D ⁷	Fil.	1.25	0.05	Class-A Amplifier	135	3	67.5	0.4	1.7	800000	600	480	—	—	—	959
1609	Pentode Amplifier	5-pin S.	5B	Fil.	1.1	0.25	Class-A Amplifier	135	2.5	67.5	0.65	2.5	400000	725	300	—	—	—	1609

¹ Refer to Receiving Tube Diagrams.
² M. — Medium; S. — Small; O. — Octal; L. — Loktal.
³ Cathode terminal is mid-point of filament; use series connection with 4 volts, parallel with 2 volts.
⁴ Triodes connected in parallel.
⁵ Idling current, both plates.
⁶ Filament mid-point tap permits series or parallel connection.
⁷ "Acorn" type; miniature unbase tubes for ultra-high frequencies. See Acorn Tube Socket Connections.

TABLE XI—CONTROL AND REGULATOR TUBES

Type	Name	Base ¹	Socket Connections ²	Cathode	Fil. or Heater		Use	Peak Anode Voltage	Max. Anode Current ³	Minimum Starting Voltage	Operating Voltage	Operating Current ⁴	Grid Resistor	Tube Voltage Drop	Type
					Volts	Amps.									
0A4G	Gas Triode	6-pin O.	4V	Cold	—	—	Cold-Cathode Starter-Anode Relay Tube	500	100	—	—	—	—	—	0A4G
2A4G	Thyratron	8-pin O.	5S	Fil.	2.5	2.5	Control Tube	—	—	—	—	—	—	15	2A4G
313C	Double Gap Gas Tube	4-pin S.	—	Cold	—	—	Relay Tube, Rectifier or Voltage Regulator	—	—	—	—	—	—	—	313C
333A	Three-Element Gas Tube	Special ¹⁴	—	Cold	—	—	Relay Tube or Rectifier	—	—	—	—	—	—	—	333A
346A	Three-Element Gas Tube	Special ¹⁶	—	Cold	—	—	Relay Tube or Rectifier	—	—	—	—	—	—	—	346A
874	Voltage Regulator	4-pin M.	4S	Cold	—	—	Voltage Regulator ³	—	—	125	90	10-50	—	—	874
876	Current Regulator	Mogul	—	—	—	—	Current Regulator ⁹	—	—	—	40-60	1.7	—	—	876
884	Gas Triode	6-pin O.	6Q	Htr.	6.3	0.6	Sweep Circuit Oscillator Grid-Controlled Rectifier	300	300	—	—	2	25000 ¹	—	884
885	Gas Triode	5-pin S.	5A	Htr.	2.5	1.4	Same as Type 884	—	—	—	—	75	25000 ¹	—	885
886	Current Regulator	Mogul	—	—	—	—	Current Regulator ⁵	—	—	—	40-60	2.05	—	—	886
967	Mercury Vapor Triode	4-pin M.	F ¹⁰	Fil.	2.5	5.0	Grid-Controlled Rectifier	2500	500	5 ¹¹	—	—	—	10-24	967
991	Glow Discharge Tube	Bayonet ¹⁸	—	—	—	—	Voltage Regulator	650	100	87	48-67	2.0	—	—	991
2050	Gas Tetrode	8-pin O.	8BA	Htr.	6.3	0.6	Grid-Controlled Rectifier	650	100	4 ¹⁰	—	—	0.1-10 meg.	8	2050
2051	Gas Tetrode	8-pin O.	8BA	Htr.	6.3	0.6	Grid-Controlled Rectifier	350	75	4 ¹⁰	—	—	0.1-10 meg.	14	2051
KY21	Gas Triode	4-pin M.	—	Fil.	2.5	10.0	Grid-Controlled Rectifier	—	—	—	3000	500	—	—	KY21
RK62	Gas Triode	4-pin S.	4D	Fil.	1.4	0.05	Relay Tube ⁶	45	1.5	—	3.0-45	0.1-1.5	—	15	RK62
RM208	Permatron	4-pin M.	—	Fil.	2.5	5.0	Controlled Rectifier ⁷	7500 ⁸	1000	—	—	—	—	15	RM208
RM209	Permatron	4-pin M.	—	Fil.	5.0	10.0	Controlled Rectifier ⁷	7500 ⁸	5000	—	—	—	—	15	RM209
VR90	Voltage Regulator	7-pin O.	4SA	—	—	—	Voltage Regulator	—	—	125	90	10-30 ⁹	—	—	VR90
VR105	Voltage Regulator	6-pin O.	4SB	—	—	—	Voltage Regulator	—	—	137	105	5-30 ⁹	—	—	VR105
VR150	Voltage Regulator	6-pin O.	4SB	—	—	—	Voltage Regulator	—	—	180	150	5-30 ⁹	—	—	VR150
KY866	Mercury Vapor Triode	4-pin M.	F ¹⁰	Fil.	2.5	5.0	Grid-Controlled Rectifier	10000	1000	100-150	—	—	—	—	KY866

¹ M.—Medium, S.—Small, O.—Octal.
² Refer to Receiving Tube Diagrams.
³ In ma.
⁴ Not less than 1000 ohms per grid volt; 500,000 ohms max.
⁵ For use in series with power transformer primary.
⁶ For use as self-quenching super-regenerative detector with high-resistance relay (5000-10000 ohms) in anode circuit.
⁷ For use as grid-controlled rectifier or with external magnetic control, RM-208 has characteristics of 866, RM-209 of 872.
⁸ When under control peak inverse rating is reduced to 2500.
⁹ Sufficient resistance must be used in series with tube to limit current to 30 ma.
¹⁰ Refer to Transmitting Tube Diagrams.
¹¹ At 1000 anode volts.
¹² At 50 anode volts and O Grid No. 2 volts.
¹³ At 250 anode volts and O Grid No. 2 volts.
¹⁴ Flexible colored leads with special terminals.
¹⁵ Special base for standard connection. Resistor mounted in base.
¹⁶ Candelabra type, double contact.

TABLE XII—CATHODE-RAY TUBES AND KINESCOPES

Type	Name	Socket Connections ¹	Heater Volts	Amps.	Use	Size	Anode No. 2 Voltage	Anode No. 1 Voltage	Cut-Off Grid Voltage ²	Grid No. 2 Voltage	Signal-Swing Voltage	Max. Input Voltage ³	Screen Input Power ⁴	Deflection Sensitivity ⁵			Screen Persistence ⁶	Pattern Color ⁷	Type
														D ₁	D ₂	D ₃ , D ₄			
3AP1/906-P1	Electrostatic Cathode-Ray	7N	2.5	2.1	Oscillograph Television	3"	1500	475	—	—	—	—	10	0.92	0.93	—	P1	Green	3AP1/906-P1
3AP4/906-P4	Electrostatic Cathode-Ray	—	—	—	—	—	1000	345	—	—	—	600	—	0.37	0.29	—	P4	White	3AP4/906-P4
5AP1/1805-P1	Electrostatic Picture Tube	10A	6.3	0.6	Oscillograph Television	5"	2000	575	- 86	—	—	500	10	0.17	0.21	—	P1	Green	5AP1/1805-P1
5AP4/1805-P4	Electrostatic Picture Tube	—	—	—	—	—	1500	430	- 64	—	—	—	—	0.33	0.28	—	P4	White	5AP4/1805-P4
5BP1/1802-P1	Electrostatic Picture Tube	10A	6.3	0.6	Oscillograph Television	5"	2000	425	- 85	—	—	500	10	0.3	0.33	—	P1	Green	5BP1/1802-P1
5BR4/1802-P4	Electrostatic Picture Tube	—	—	—	—	—	1500	310	- 62	—	—	—	—	0.4	0.44	—	P4	White	5BR4/1802-P4

¹ M.—Medium, S.—Small, O.—Octal.
² Refer to Receiving Tube Diagrams.
³ In ma.
⁴ Not less than 1000 ohms per grid volt; 500,000 ohms max.
⁵ For use in series with power transformer primary.
⁶ For use as self-quenching super-regenerative detector with high-resistance relay (5000-10000 ohms) in anode circuit.
⁷ For use as grid-controlled rectifier or with external magnetic control, RM-208 has characteristics of 866, RM-209 of 872.
⁸ When under control peak inverse rating is reduced to 2500.
⁹ Sufficient resistance must be used in series with tube to limit current to 30 ma.
¹⁰ Refer to Transmitting Tube Diagrams.
¹¹ At 1000 anode volts.
¹² At 50 anode volts and O Grid No. 2 volts.
¹³ At 250 anode volts and O Grid No. 2 volts.
¹⁴ Flexible colored leads with special terminals.
¹⁵ Special base for standard connection. Resistor mounted in base.
¹⁶ Candelabra type, double contact.

TABLE XII—CATHODE-RAY TUBES AND KINESCOPIES—Continued

Type	Name	Socket Connections ¹	Heater		Use	Size	Anode		Cut-Off Grid Voltage ²	Grid No. 2 Voltage	Signal-Swing Voltage ³	Max. Input Voltage ⁴	Screen Input Power ⁴	Deflection Sensitivity ⁵		Screen Persistence ⁶	Pattern Color ⁶	Type
			Volts	Amps.			No. 1 Voltage	No. 2 Voltage						D ₁ D ₂	D ₃ D ₄			
7AP4	Electromagnetic Picture Tube	5AJ	2.5	2.1	Television	7"	3500	1000	-67.5	—	—	—	9.5	—	—	P4	White	7AP4
9AP4/ 1804-P4	Electromagnetic Picture Tube	6AL	2.5	2.1	Television	9"	7000	1425	-75	250	25	—	10	—	—	P4	White	9AP4/ 1804-P4
12AP4/ 1803-P4	Electromagnetic Picture Tube	6AL	2.5	2.1	Television	12"	7000	1460	-75	250	25	—	10	—	—	P4	White	12AP4/ 1803-P4
902	Electrostatic Cathode-Ray	A ⁸	6.3	0.6	Oscillograph	2"	600	150	-80	—	—	350	5	0.19	0.22	P1	Green	902
							400	100	—	—	—	—	—	0.28	0.33			
903	Electromagnetic Cathode-Ray	6AL	2.5	2.1	Oscillograph	9"	7000	1360	—	250	—	—	10	—	—	P1	Green	903
							4600	900	-120	250	—	—	—	—	—			
							3000	580	—	350	—	—	—	—	—			
							1000	195	—	100	—	—	—	—	—			
904	Electrostatic-Magnetic Cathode-Ray	C ⁹	2.5	2.1	Oscillograph	5"	4600	970	-140	250	—	4000	10	0.09	—	P1	Green	904
							3000	630	—	100	—	—	—	0.13	—			
							1000	310	—	100	—	—	—	0.40	—			
905	Electrostatic Cathode-Ray	D ⁹	2.5	2.1	Oscillograph	5"	2000	450	-60	—	—	1000	10	0.19	0.23	P1	Green	905
							1000	225	—	—	—	—	—	0.38	0.46			
907	Electrostatic Cathode-Ray	D ⁹	2.5	2.1	Oscillograph	5"	15000	3000	—	250	—	—	10	0.028	0.034	P5	Blue	907
908	Electrostatic Cathode-Ray	7N	2.5	2.1	Oscillograph	3"	10000	2000	-125	250	—	7000	10	0.041	0.051	P5	Blue	908
909	Electrostatic Cathode-Ray	D ⁹	2.5	2.1	Oscillograph	5"	5000	1000	—	250	—	—	—	0.083	0.102	P2	Blue	909
910	Electrostatic Cathode-Ray	7N	2.5	2.1	Oscillograph	3"	7000	1500	-90	—	—	250	5	0.07	0.10	P2	Blue	910
911	Electrostatic Cathode-Ray	7N	2.5	2.1	Oscillograph	3"	250	50	—	—	—	—	—	0.15	0.21	P1	Green	911
							3000	625	—	250	—	—	—	0.073	0.093			
							3000	450	-35	200	20	—	—	0.102	0.130			
912	Electrostatic Cathode-Ray	F ⁹	2.5	2.1	Oscillograph	5"	3000	450	-35	200	20	—	10	0.204	0.260	P1	Green	912
							2500	375	—	—	15	—	—	—	—			
913	Electrostatic Cathode-Ray	A ⁸	6.3	0.6	Oscillograph	1"	600	150	—	—	—	—	—	—	—	P1	Green	913
							500	100	—	—	—	—	—	—	—			
914	Electrostatic Cathode-Ray	G ⁹	2.5	2.1	Oscillograph	9"	5000	915	-125	250	—	3000	10	0.073	0.093	P1	Green	914
							2500	460	—	250	—	—	—	0.102	0.130			
							6000	1250	—	250	25	—	—	0.204	0.260			
1800	Electromagnetic Kinescope	6AL	2.5	2.1	Television	9"	4500	925	-75	250	25	—	10	—	—	P3	Yellow	1800
							3000	625	—	200	20	—	—	—	—			
1801	Electromagnetic Kinescope	H ⁹	2.5	2.1	Television	5"	3000	450	-35	200	20	—	10	—	—	P3	Yellow	1801
							2500	375	—	—	15	—	—	—	—			
							600	150	—	—	—	—	—	0.16	0.17			
2002	Electrostatic Cathode-Ray	A ⁸	6.3	0.6	Oscillograph	2"	500	100	—	—	—	—	—	0.18	0.20	Med.	Green	2002
							400	80	—	—	—	—	—	0.24	0.26			
2005	Electrostatic Cathode-Ray	A ^{8,9}	2.5	2.1	Television	5"	2000	1000	-35	200	—	—	10	0.5	0.56	—	—	2005
							600	120	—	—	—	—	—	—	—			
24-XH	Electrostatic Cathode-Ray	A ⁸	6.3	0.6	Oscilloscope	2"	500	100	-60	—	—	—	10	0.14	0.16	Short	Green	24-XH
							400	80	—	—	—	—	—	0.17	0.19			
							500	100	—	—	—	—	—	0.21	0.23			

¹ Refer to Receiving Tube Diagrams.
² For current cut-off. Control grid should never be allowed to go positive.
³ Between Anode No. 2 and any deflecting plate.
⁴ In mw./sq. cm., max.
⁵ In mm./volt d.c.
⁶ Phosphorescent material used in screen determines persistence.
P1 is phosphor of medium persistence, P2 and P3 also of medium persistence but especially suited for television. P4 is of short persistence but especially suited for oscillographic use.
⁷ The 911 is identical to 906 except for the gun material, which is designed to be especially free from magnetization effects.
⁸ Cathode connected to pin 7.
⁹ Refer to Cathode-Ray Tube Base Diagrams.

TABLE XIII—RECTIFIERS—RECEIVING AND TRANSMITTING

See also Table XI—Control and Regulator Tubes

Type No.	Name	Base ²	Socket Connections ¹	Cathode	Fil. or Heater		Max. A.C. Voltage Per Plate	Max. D.C. Output Current Ma.	Max. Inverse Peak Voltage	Max. Peak Plate Current Ma.	Type ⁷
					Volts	Amps.					
BA	Full-Wave Rectifier	4-pin M.	4J	Cold	—	—	350	350	Tube drop 80 v.		G
BH	Full-Wave Rectifier	4-pin M.	4J	Cold	—	—	350	125	Tube drop 90 v.		G
BR	Half-Wave Rectifier	4-pin M.	4J	Cold	—	—	300	50	Tube drop 60 v.		G
OZ4	Full-Wave Rectifier	6-pin O.	4R	Cold	—	—	350	30-75	1250	200	G
1 ⁵	Half-Wave Rectifier	4-pin S.	4G	Htr.	6.3	0.3	350	50	1000	400	M
1-V ⁵	Half-Wave Rectifier	4-pin S.	4G	Htr.	6.3	0.3	350	50	—	—	V
2V3G	Half-Wave Rectifier	6-pin O.	6BA	Fil.	2.5	5.0	—	2.0	16500	12	V
2W3	Half-Wave Rectifier	5-pin O.	4X	Fil.	2.5	1.5	350	55	—	—	V
2X2	Half-Wave Rectifier	4-pin M.	4B	Fil.	2.5	1.75	4500 ¹¹	7.5	—	—	V
2Y2	Half-Wave Rectifier	4-pin M.	4P	Fil.	2.5	1.75	4400 ¹¹	5.0	—	—	V
2Z2	Half-Wave Rectifier	4-pin M.	4B	Fil.	2.5	1.5	350	50	—	—	V
5T4 ³	Full-Wave Rectifier	5-pin O.	5T	Fil.	5.0	3.0	450	250	1250	800	V
5U4G	Full-Wave Rectifier	8-pin O.	5T	Fil.	5.0	3.0	Same as Type 5Z3				V
5V4G	Full-Wave Rectifier	8-pin O.	5L	Htr.	5.0	2.0	Same as Type 83V				V
5W4	Full-Wave Rectifier	5-pin O.	5T	Fil.	5.0	1.5	350	110	1000	—	V
5X3	Full-Wave Rectifier	4-pin M.	4C	Fil.	5.0	2.0	1275	30	—	—	V
5X4G	Full-Wave Rectifier	8-pin O.	5Q	Fil.	5.0	3.0	Same as 5Z3				V
5Y3G	Full-Wave Rectifier	5-pin O.	5T	Fil.	5.0	2.0	Same as Type 80				V
5Y4G	Full-Wave Rectifier	8-pin O.	5Q	Fil.	5.0	2.0	Same as Type 80				V
5Z3	Full-Wave Rectifier	4-pin M.	4C	Fil.	5.0	3.0	500	250	1400	—	V
5Z4 ³	Full-Wave Rectifier	5-pin O.	5L	Htr.	5.0	2.0	400	125	1100	—	V
6W5G	Full-Wave Rectifier	6-pin O.	6S	Htr.	6.3	0.9	350	100	1250	350	V
6X5 ³	Full-Wave Rectifier	6-pin O.	6S	Htr.	6.3	0.5	350	75	—	—	V
6Z3	Half-Wave Rectifier	4-pin M.	4G	Fil.	6.3	0.3	350	50	—	—	V
6Z4	Full-Wave Rectifier	5-pin S.	5D	Htr.	6.3	0.5	350	50	—	—	V
6Z5	Full-Wave Rectifier	6-pin S.	6K	Htr.	6.3	0.6	230	60	—	—	V
6ZY5G	Full-Wave Rectifier	6-pin O.	6S	Htr.	6.3	0.3	350	35	1000	150	V
7Y4	Full-Wave Rectifier	8-pin L.	5AB	Htr.	7.0 ¹²	0.53	350	60	—	—	V
12A7	Rectifier-Pentode ¹⁴	7-pin S.	7K	Htr.	12.6	0.3	125	30	—	—	V
12Z3	Half-Wave Rectifier	4-pin S.	4G	Htr.	12.6	0.3	250	60	—	—	V
12Z5	Voltage-Doubling Rectifier	7-pin M.	7L	Htr.	12.6	0.3	225	60	—	—	V
14Z3	Half-Wave Rectifier	4-pin S.	4G	Htr.	14 ¹²	0.3	250	60	—	—	V
25A7G	Rectifier-Pentode ¹⁴	8-pin O.	8F	Htr.	25	0.3	125	75	—	—	V
25X6GT	Voltage-Doubling Rectifier	7-pin O.	7Q	Htr.	25	0.15	125	60	—	—	V
25Y4GT	Half-Wave Rectifier	6-pin O.	5AA	Htr.	25	0.15	125	75	—	—	V
25Y5	Voltage-Doubling Rectifier	6-pin S.	6E	Htr.	25	0.3	250	85	—	—	V
25Z3	Half-Wave Rectifier	4-pin S.	4G	Htr.	25	0.3	250	50	—	—	V
25Z4	Half-Wave Rectifier	6-pin O.	5AA	Htr.	25	0.3	125	125	—	—	V
25Z5	Rectifier-Doubler	6-pin S.	6E	Htr.	25.0	0.3	125	100	—	500	V
25Z6	Rectifier-Doubler	7-pin O.	7Q	Htr.	25.0	0.3	125	100	—	500	V
32L7GT	Rectifier-Tetrode ¹⁴	8-pin O.	8F	Htr.	32.5	0.3	125	60	—	—	V
35Z3-LT	Half-Wave Rectifier	8-pin L.	4Z	Htr.	35	0.15	250 ¹³	100	700	600	V
35Z4GT	Half-Wave Rectifier	6-pin O.	5AA	Htr.	35	0.15	250	100	—	—	V
35Z5G	Half-Wave Rectifier	6-pin O.	6AD	Htr.	35 ⁸	0.15	125	100	—	—	V

TABLE XIII—RECTIFIERS—RECEIVING AND TRANSMITTING—Continued

See also Table XI—Control and Regulator Tubes

Type No.	Name	Base ²	Socket Connections ¹	Cathode	Fil. or Heater		Max. A.C. Voltage Per Plate	Max. D.C. Output Current Ma.	Max. Inverse Peak Voltage	Max. Peak Plate Current Ma.	Type ⁷
					Volts	Amps.					
35Z6G	Voltage Doubler	6-pin O.	6AD	Htr.	35	0.3	125	110	—	500	V
40Z5GT	Half-Wave Rectifier	6-pin O.	6AD	Htr.	40 ⁸	0.15	125	100	—	—	V
45Z5GT	Half-Wave Rectifier	6-pin O.	6AD	Htr.	45 ⁸	0.15	125	100	—	—	V
50Y6GT	Full-Wave Rectifier	7-pin O.	7Q	Htr.	50	0.15	125	85	—	—	V
50Z6G	Voltage-Doubling Rectifier	7-pin O.	7Q	Htr.	50	0.3	125	150	—	—	V
50Z7G	Voltage-Doubling Rectifier	8-pin O.	8AN	Htr.	50	0.15	117	65	—	—	V
70A7GT	Rectifier-Tetrode ¹⁴	8-pin O.	8AA	Htr.	70	0.15	125	60	—	—	V
70L7GT	Rectifier-Tetrode ¹⁴	8-pin O.	8AA	Htr.	70	0.15	117	70	—	350	V
80	Full-Wave Rectifier	4-pin M.	4C	Fil.	5.0	2.0	350 400 550 ⁶	125 110 135	—	—	V
81	Half-Wave Rectifier	4-pin M.	4B	Fil.	7.5	1.25	700	85	—	—	V
82	Full-Wave Rectifier	4-pin M.	4C	Fil.	2.5	3.0	500	125	1400	400	M
83	Full-Wave Rectifier	4-pin M.	4C	Fil.	5.0	3.0	500	250	1400	800 ⁷	M
83-V	Full-Wave Rectifier	4-pin M.	4L	Htr.	5.0	2.0	400	200	1100	—	V
84/6Z4	Full-Wave Rectifier	5-pin S.	5D	Htr.	6.3	0.5	350	60	1000	—	V
117L7GT	Rectifier-Tetrode ¹⁴	8-pin O.	8AO	Htr.	117	0.09	105	75	—	—	V
117M7GT	Rectifier-Tetrode ¹⁴	8-pin O.	8AO	Htr.	117	0.09	117	75	—	—	V
117N7GT	Rectifier-Tetrode ¹⁴	8-pin O.	8AV	Htr.	117	0.09	117	75	350	450	V
117Z6G	Full-Wave Rectifier	7-pin O.	7AR	Htr.	117 58.5	0.075 0.15	117	60	—	—	V
836	Half-Wave Rectifier	4-pin M.	A ⁴	Htr.	2.5	5.0	—	—	5000	1000	V
866	Half-Wave Rectifier	4-pin M.	A ⁴	Fil.	2.5	5.0	—	250 ¹⁰	7500	1000	M
866-A	Half-Wave Rectifier	4-pin M.	A ⁴	Fil.	2.5	5.0	—	250 ¹⁰	10000	1000	M
866B	Half-Wave Rectifier	4-pin M.	A ⁴	Fil.	5.0	5.0	—	—	8500	1000	M
866Jr.	Half-Wave Rectifier	4-pin M.	4B	Fil.	2.5	2.5	1250	250 ⁹	—	—	M
HY-866 Jr.	Half-Wave Rectifier	4-pin M.	A ⁴	Htr.	2.5	3.0	1250	250 ⁹	3500	—	M
RK-866	Half-Wave Rectifier	4-pin M.	A ⁴	Fil.	2.5	5.0	—	250 ¹⁰	10000	1000	M
871	Half-Wave Rectifier	4-pin M.	A ⁴	Fil.	2.5	2.0	1750	250	5000	500	M
878 ¹¹	Half-Wave Rectifier	4-pin M.	A ⁴	Fil.	2.5	5.0	7100	5	20000	—	V
879 ¹¹	Half-Wave Rectifier	4-pin S.	A ⁴	Fil.	2.5	1.75	2650	7.5	7500	100	V
872	Half-Wave Rectifier	4-pin J.	P ⁴	Fil.	5.0	10.0	—	—	7500	5000	M
872-A	Half-Wave Rectifier	4-pin J.	P ⁴	Fil.	5.0	10.0	—	—	10000	5000	M
975 A	Half-Wave Rectifier	4-pin J.	P ⁴	Fil.	5.0	10.0	—	1500	15000	6000	M
1616	Half-Wave Rectifier	4-pin M.	B ⁴	Fil.	2.5	5.0	—	130	5500	800	V
RK19	Full-Wave Rectifier	4-pin M.	B ⁴	Htr.	7.5	2.5	1250	200 ¹⁰	3500	600	V
RK21	Half-Wave Rectifier	4-pin M.	A ⁴	Htr.	2.5	4.0	1250	200 ¹⁰	3500	600	V
RK22	Full-Wave Rectifier	4-pin M.	B ⁴	Htr.	2.5	8.0	1250	200 ¹⁰	3500	600	V
RK60	Full-Wave Rectifier	4-pin M.	B ⁴	Fil.	5	3.0	750	250	2120	—	V

¹ Refer to Receiving Tube Diagrams.

² M.—medium; S.—small; O.—octal; L.—Loktal; J.—jumbo.

³ Metal tube series.

⁴ Refer to Transmitting Tube Diagrams.

⁵ Types 1 and 1-V interchangeable.

⁶ With input choke of at least 20 henrys.

⁷ M.—Mercury-vapor type; V.—high-vacuum type; G.—Gaseous Type.

⁸ Tapped for pilot lamps.

⁹ Per pair with choke input.

¹⁰ Condenser input.

¹¹ For use with cathode-ray tubes.

¹² Maximum rating, corresponding to 130-volt line condition, normal rating is 12.6 v. for 117-v. line.

¹³ With 100 ohms min. resistance in series with plate; without series resistor, maximum r.m.s. plate rating is 117 volts.

¹⁴ For other data, see Table IX.

TABLE XIV — TRIODE TRANSMITTING TUBES

Type	Max. Plate Dissipation Watts		Cathode		Max. Plate Voltage	Max. Plate Current Ma.	Max. D.C. Grid Current Ma.	Amp. Factor	Inter-electrode Capacitances (μ fd.)			Base ²	Socket Connections ¹	Typical Operation	Plate Voltage	Grid Voltage	Plate Current Ma.	D.C. Grid Current Ma.	Approx. Grid Driving Power Watts ⁵	Approx. Carrier Output Power Watts	Type
	Volts	Amps.	Grid to Fil.	Grid to Plate					Plate to Fil.												
RK94	1.5	2.0	0.12	3.5	5.5	3.0	4-pin S.	C	Class-C Amp.-Oscillator	180	— 45	16.5	6.0	0.5	2.0	RK94					
RK33 ¹⁰	2.5	2.0	0.12	3-2	3-2	2.5	7-pin S.	Y	Class-C Amp.-Oscillator	250	— 60	20	6.0	0.54	3.5	RK33					
HY114*	2.5	1.4	0.12	1.2	1.7	0.6	5-pin O.	Y	Class-C Amp.-Oscillator	180	-92.5	15	1.4	0.15	2.0 ⁶	HY114					
HY615*	3.5	6.3	0.15	1.5	1.7	1.7	5-pin O.	Z	Class-C Amp.-Oscillator	300	— 35	20	1.4	0.2	4.0 ⁶	HY615					
RK34	10 ⁸	6.3	0.8	4.2	2.7	0.8	7-pin M.	CC	Class-C Amp. Plate-Mod.	300	— 36	20	2.5	0.4	4.0 ⁶	RK34					
205D	14	4.5	1.6	5.2	4.8	3.3	4-pin M.	C	Class-C Amp.-Oscillator	400	-112	45	10	1.5	10	205D					
843	15	2.5	2.5	4.0	4.5	4.0	5-pin M.	D	Class-C Amp.-Oscillator	350	-144	35	10	1.7	7.1	843					
RK59 ⁸	15	6.3	1.0	5.0	9.0	1.0	4-pin M.	W	Class-C Amp. (Plate-Mod.)	350	-150	30	7.0	1.6	5.0	RK59					
HY31Z ¹¹	15 ¹⁴	6.3	2.5	5.0	5.0	1.9	4-pin M.	W	Class-C Amp.-Oscillator	500	— 60	90	14	1.3	32	HY31Z					
HY75	15	6.3	2.5	—	—	—	5-pin O.	Y	Class-C Amp.-Oscillator	450	-90	100	15	—	33	HY75					
1602	15	7.5	1.25	4.0	7.0	3.0	4-pin M.	C	Class-C Amp. Plate-Mod.	450	-90	80	20	—	24	1602					
841	15	7.5	1.25	4.0	7.0	3.0	4-pin M.	C	Class-C Amp. (Telephony)	450	-115	55	15	3.3	13	841					
10 RK10 ¹⁰	15	7.5	1.25	3.0	8.0	4.0	4-pin M.	C	Class-C Amp. (Telephony)	350	-135	45	15	3.5	8.0	10 RK10					
RK100 ¹⁰	15	6.3	0.9	23	19	3.0	6-pin M.	HH	Class-C Amp. (Telephony)	450	-100	50	12	2.2	19	RK100					
1608	20	2.5	2.5	8.5	9.0	3.0	4-pin M.	C	Grid-Modulated Amp.	110	—	80	8.0	—	3.5	1608					
310	20	7.5	1.25	4.0	7.0	2.2	4-pin M.	C	Class-C Amplifier ¹⁰	110	—	185	40	2.1	12	310					
801	20	7.5	1.25	4.5	6.0	1.5	4-pin M.	C	Class-C Amp. (Telephony)	425	-90	95	20	3.0	27	801					
T20 ⁹	20	7.5	1.75	4.9	5.1	0.7	4-pin M.	F	Class-C Amp. (Telephony)	350	-80	85	20	3.0	18	T20					
TZ20 ⁹	20	7.5	1.75	5.3	5.0	0.6	4-pin M.	F	Class-C Amp. (Telephony)	600	-150	65	15	4.0	25	TZ20					
RK11	25	6.3	3.0	7.0	7.0	0.9	4-pin M.	F	Class-C Amp. (Telephony)	500	-190	55	15	4.5	18	RK11					
									Class-C Amp. (Telephony)	600	-150	55	15	4.5	18						
									Class-C Amp. Plate-Mod.	750	-85	85	18	3.6	44						
									Class-C Amp. Plate-Mod.	750	-140	70	15	3.6	38						
									Class-C Amp. (Telephony)	750	-40	85	28	3.75	44						
									Class-C Amp. Plate-Mod.	750	-100	70	23	4.8	38						
									Class-C Amp. (Telephony)	750	-120	105	21	3.2	55						
									Class-C Amp. Plate-Mod.	600	-150	85	24	3.7	38						
									Grid-Modulated Amp.	750	-130	38	1.2	2.7	12						

TABLE XIV — TRIODE TRANSMITTING TUBES — Continued

Type	Cathode		Max. Plate Dissipation Watts	Max. Plate Voltage	Max. Plate Current Ma.	Max. D.C. Grid Current Ma.	Amp. Factor	Interelectrode Capacitances (μ fd.)			Base ²	Socket Connections	Typical Operation	Plate Voltage	Grid Voltage	Plate Current Ma.	D.C. Grid Current Ma.	Approx. Grid Driving Power Watts ⁵	Approx. Carrier Output Power Watts	Type
	Volts	Amps.						Grid to Fil.	Grid to Plate	Plate to Fil.										
RK12	6.3	3.0	25	750	105	40	100	7.0	7.0	0.9	4-pin M.	F	750	-100	105	35	5.2	55	RK12	
HK24	6.3	3.0	25	2000	75	30	25	2.5	1.7	0.4	4-pin S.	F	2000	-140	56	18	4.0	90	HK24	
HY30Z	6.3	2.25	25	850	90	25	90	4.9	5.1	1.7	4-pin M.	F ³	850	-75	90	20	3.5	44	HY30Z	
HY25	7.5	2.25	25	800	75	25	55	4.2	4.6	1.0	4-pin M.	F	750	-45	75	15	2.0	42	HY25	
1623 ⁹	6.3	2.5	30	1000	100	25	20	5.7	6.7	0.9	4-pin M.	F	1000	-90	100	20	3.1	75	1623	
Twin 30 ^{8,11}	6.0	4.0	30	1500	85	25	32	1.9	2.0	0.3	4-pin M.	X	1500	-100	150 ⁸	40 ⁸	15	22.5	Twin 30	
316A [*]	2.0	3.65	30	450	80	12	6.5	1.2	1.6	0.8	None ³	—	450	—	80	12	—	7.5	316A	
809 ⁹	6.3	2.5	30	1000	125	—	50	5.7	6.7	0.9	4-pin M.	F	1000	-75	100	25	3.8	75	809	
RK30 ¹⁶	7.5	3.25	35	1250	80	25	15	2.75	2.5	2.75	4-pin M.	E	1250	-180	90	18	5.2	85	RK30	
800	7.5	3.25	35	1250	80	25	15	2.75	2.5	2.75	4-pin M.	E	1250	-900	70	15	4.0	65	800	
1628 [*]	3.5	3.25	40	1000	60	15	23	2.0	2.0	0.4	None ³	—	1000	-65	50	15	1.7	35	1628	
RK18 ¹⁰	7.5	3.0	40	1250	100	40	18	6.0	4.8	1.8	4-pin M.	F	1250	-160	100	12	2.8	95	RK18	
RK31	7.5	3.0	40	1250	100	35	170	7.0	1.0	2.0	4-pin M.	F	1250	-80	100	30	3.0	90	RK31	
HY40	7.5	2.25	40	1000	115	25	25	5.8	6.3	1.8	4-pin M.	F	1000	-90	115	20	5.0	85	HY40	
HY40Z	7.5	2.5	40	1000	115	30	80	5.8	6.3	1.8	4-pin M.	F	1000	-27.5	115	25	5.0	85	HY40Z	
T40 ⁹	7.5	2.5	40	1500	150	40	25	4.5	4.8	0.8	4-pin M.	F	1500	-140	150	28	9.0	158	T40	

TABLE XIV — TRIODE TRANSMITTING TUBES — Continued

Type	Cathode		Max. Plate Dissipation Watts	Max. Plate Current Ma.	Max. D.C. Grid Current Ma.	Amp. Factor	Interelectrode Capacitances ($\mu\text{mfd.}$)			Base ²	Socket Connections ¹	Typical Operation	Plate Voltage	Grid Voltage	Plate Current Ma.	D.C. Grid Current Ma.	Approx. Grid Driving Power Watts ⁵	Approx. Carrier Output Power Watts	Type
	Volts	Amps.					Grid to Fil.	Grid to Plate	Plate to Fil.										
TZ40 ⁹	7.5	2.5	40	150	45	62	4.8	5.0	0.8	4-pin M.	F	1500	-90	150	38	10	165	TZ40	
HV57	6.3	2.25	40	110	25	50	4.9	5.1	1.7	4-pin M.	F	850	-48	110	15	2.5	70	HV57	
756 ¹⁶	7.5	2.0	40	110	25	8.0	3.0	7.0	2.7	4-pin M.	C	850	-180	110	18	7.0	55	756	
825 ¹⁶	7.5	2.0	40	110	20	20	3.5	8.0	2.7	4-pin M.	C	850	-200	50	2.0	3.0	15	830	
830 ¹⁶	10	2.15	40	110	18	8.0	4.9	9.9	2.2	4-pin M.	C	750	-200	50	14	4.8	90	RK32	
RK32 ¹⁶	7.5	3.25	50	1250	100	11	2.5	3.4	0.7	4-pin M.	E	1000	-310	100	21	8.7	70	RK32	
RK35 ¹⁶	7.5	4.0	50	1500	125	9.0	3.5	2.7	0.4	4-pin M.	E	1500	-250	115	15	5.0	120	RK35	
RK37	7.5	4.0	50	1500	125	28	3.5	3.2	0.2	4-pin M.	E	1500	-130	115	30	7.0	192	RK37	
UH50	7.5	3.25	50	1250	125	10.6	2.2	2.6	0.3	4-pin M.	E	1250	-150	100	23	5.6	90	UH50	
UH51*	5.0	6.5	50	2000	175	10.6	2.2	2.3	0.3	4-pin M.	E	2000	-500	150	30	2.4	26	UH51	
HK54	5.0	5.0	50	3000	150	27	1.9	1.9	0.2	4-pin M.	E	3000	-400	85	2.0	8.0	65	HK54	
HK154 ¹⁶	5.0	6.5	50	1500	175	6.7	4.3	5.9	1.1	4-pin M.	E	1500	-450	52	20	15	200	HK154	
304A ¹⁶ 304B*	7.5	3.25	50	1250	100	11	2.0	2.5	0.7	4-pin M.	E	1250	-200	100	—	—	85	304A 304B	
356A	5.0	5.0	50	1500	120	50	2.25	2.75	1.0	Special	DD	1500	-60	100	35	—	100	356A	
808	7.5	4.0	50	1500	150	47	5.3	2.8	0.15	4-pin M.	E	1500	-200	125	30	9.5	140	808	
834*	7.5	3.25	50	1250	100	10.5	2.2	2.6	0.6	4-pin M.	E	1250	-225	90	15	4.5	75	834	
841A ¹⁶ 8415W	10 10	2.0 2.0	50 50	1250 1000	150 150	14.6 14.6	3.5 —	9.0 9.0	2.5 —	4-pin M. 4-pin M.	F F	1000	-310	90	17.5	6.5	58	841A 8415W	

TABLE XIV — TRIODE TRANSMITTING TUBES — Continued

Type	Cathode		Max. Plate Dissipation Watts	Max. D.C. Grid Current Ma.	Amp. Factor	Interelectrode Capacitances (μmfd.)			Base ²	Socket Connections ¹	Typical Operation	Plate Voltage	Grid Voltage	Plate Current Ma.	D.C. Grid Current Ma.	Approx. Grid Driving Power Watts	Approx. Carrier Output Power Watts	Type
	Volts	Amps.				Grid to Fil.	Grid to Plate	Plate to Fil.										
T55	7.5	3.0	55	40	20	5.0	3.9	1.2	4-pin M.	F	Class-C Amp. (Telegraphy) Class-C Amp. Plate-Mod.	1500	-170	150	18	6.0	170	T55
811 ^o	6.3	4.0	55	50	160	5.5	5.5	0.6	4-pin M.	F	Class-C Amp. (Telegraphy) Class-C Amp. Plate-Mod.	1500	-113	150	35	8.0	170	811
812 ^o	6.3	4.5	55	35	29	5.3	5.3	0.8	4-pin M.	F	Class-C Amp. (Telegraphy) Class-C Amp. Plate-Mod.	1500	-175	150	25	6.5	170	812
RK51	7.5	3.75	60	40	20	6.0	6.0	2.5	4-pin M.	F	Class-C Amp. (Telegraphy) Grid-Modulated Amp.	1500	-200	105	17	4.5	96	RK51
RK52	7.5	3.75	60	50	170	6.6	12	2.2	4-pin M.	F	Class-C Amp. (Telegraphy) Class-C Amp. Plate-Mod.	1500	-120	130	40	7.0	135	RK52
830B 930B	10	2.0	60	30	25	5.0	11	1.8	4-pin M.	F	Class-C Amp. Plate-Mod. Class-B Amp. Telephony	1000	-150	95	30	7.0	90	830-B 930-B
HY51A HY51B	7.5 10	3.5 2.25	65	25	25	6.0	7.5	2.0	4-pin M.	F	Class-C Amp. (Telegraphy) Grid-Modulated Amp.	1000	-90	150	25	7.5	105	HY51A HY51B
HY51Z	7.5	3.5	65	35	85	6.0	7.5	2.0	4-pin M.	F ¹³	Class-C Amp. (Telegraphy) Class-C Amp. Plate-Mod.	1000	-27.5	175	30	7.5	132	HY51Z
UH35 *	5.0	4.0	70	35	30	1.4	1.6	0.2	4-pin M.	F	Class-C Amp. (Telegraphy) Class-C Amp. Plate-Mod.	1500	-170	150	30	7.0	170	UH35
35T 35TG	5.0	4.0	70	35	30	3.8 1.9	1.9	0.2	4-pin M.	F	Class-C Amp. (Telegraphy) Class-C Amp. Plate-Mod.	1500	-120	100	30	5.0	120	35T 35TG
V70 V70B	10	2.5	70	25	14	5.0	9.0	2.3	4-pin J, 4-pin M.	M ¹ F	Class-C Amp. (Telegraphy) Class-C Amp. Plate-Mod.	1500	-215	130	6.0	3.0	140	V70 V70B
V70A V70C	10	2.5	70	20	25	5.0	9.5	2.0	4-pin J, 4-pin M.	M ¹ F	Class-C Amp. (Telegraphy) Class-C Amp. Plate-Mod.	1000	-110	140	30	7.0	90	V70A V70C
V70D	10	3.0	70	40	20	4.5	4.5	1.75	4-pin M.	F	Class-C Amp. (Telegraphy) Class-C Amp. Plate-Mod.	1500	-200	130	20	6.0	140	V70D
50T ¹⁶	5.0	6.0	75	30	12	2.0	2.0	0.4	4-pin M.	E	Class-C Amplifier	3000	-600	100	25	—	250	50T
75T	5.0	6.5	75	30	10.6	2.2	2.3	0.3	4-pin M.	E	Class-C Amp. Plate-Mod. Grid-Modulated Amp.	1500	-300	175	30	10	200	75T
TW75	7.5	4.15	75	60	20	3.35	1.5	0.7	4-pin M.	E	Class-C Amp.-Oscillator Class-C Amp. Plate-Mod.	2000	-175	150	37	12.7	225	TW75
HF100	10	2.0	75	30	23	3.5	4.5	1.4	4-pin M.	E	Class-C Amp. (Telegraphy) Class-C Amp. Plate-Mod. Grid-Modulated Amp.	1500	-200	150	18	6.0	170	HF100

TABLE XIV — TRIODE TRANSMITTING TUBES — Continued

Type	Max. Plate Dissipation Watts		Cathode		Max. Plate Voltage	Max. Plate Current Ma.	Max. D.C. Grid Current Ma.	Amp. Factor	Interelectrode Capacitances (pfd.)			Base	Socket Connections	Typical Operation	Plate Voltage	Grid Voltage	Plate Current Ma.	D.C. Grid Current Ma.	Approx. Grid Driving Power Watts	Approx. Carrier Output Power Watts	Type
	Watts	Watts	Volts	Amps.					Grid to Fil.	Grid to Plate	Plate to Fil.										
ZB120	75	10	2.0	10	1950	160	40	90	5.3	5.2	3.2	4-pin J.	M	Class-C Amp. (Telegraphy)	1250	-135	160	23	5.5	145	ZB120
948A	85	10	3.25	10	1250	150	50	12.5	6.5	13	4.0	4-pin J.	M	Grid-Modulated Amp.	1250	-175	150	8.0	1.5	45	948A
984D	85	10	3.25	10	1250	150	100	4.8	6.0	8.3	5.6	4-pin J.	M	Class-C Amp. (Telegraphy)	1250	-500	150	50	—	130	984D
RK36 ¹⁶	100	5.0	8.0	5.0	3000	165	35	14	4.5	5.0	1.0	4-pin M.	E	Class-C Amp. (Telephony)	2000	-360	150	30	15	200	RK36
RK38	100	5.0	8.0	5.0	3000	165	40	—	4.6	4.3	0.9	4-pin M.	E	Grid-Modulated Amp.	2000	-270	72	1.0	3.5	42	RK38
100TH	100	5.0	6.5	5.0	3000	225	50	30	2.2	2.0	0.3	4-pin M.	E	Class-B Amp. (Telephony)	3000	-910	167	45	18	400	100TH
100TL	100	5.0	6.5	5.0	3000	225	35	12	2.0	2.3	0.4	4-pin M.	E	Class-C Amp. (Telephony)	3000	-600	167	30	18	400	100TL
HK254	100	5.0	7.5	5.0	4000	200	40	25	3.3	3.4	1.1	4-pin J.	N	Class-C Amp. (Telephony)	4000	-380	190	35	30	475	HK254
RK58 ¹⁶	100	10	3.25	10	1250	175	70	—	8.5	6.5	10.5	4-pin J.	M ¹	Class-C Amp. (Telephony)	1250	-90	150	30	6.0	130	RK58
903A 303A	100	10	3.25	10	1250	175	60	25	6.5	14.5	5.5	4-pin J.	M	Class-C Amp. (Telephony)	1000	-135	150	50	16	100	903A 303A
903H	100	10	3.25	10	1500	175	60	25	6.5	11.5	1.5	4-pin J.	M ¹	Class-C Amp. (Telephony)	1500	-200	170	12	3.8	200	903H
911 311 835	100	10	3.25	10	1250	175	50	12	6.0 6.0	14.5 9.25	5.5 5.0	4-pin J.	M	Class-C Amp. (Telephony)	1000	-260	150	35	14	100	911 311 835

TABLE XIV — TRIODE TRANSMITTING TUBES — Continued

Type	Max. Plate Dissipation Watts		Cathode		Max. Plate Voltage	Max. Plate Current Ma.	Max. D.C. Grid Current Ma.	Amp. Factor	Interelectrode Capacitances (p.f.d.)			Base	Socket Connections	Typical Operation	Plate Voltage	Grid Voltage	Plate Current Ma.	D.C. Grid Current Ma.	Approx. Grid Driving Power Watts	Approx. Carrier Output Power Watts	Type
	Volts	Amps.	Grid to Fil.	Grid to Plate					Plate to Fil.												
949B 349B	100	10	3.25	1250	150	50	12.5	7.0	13.6	6.0	4-pin J.	M	Class-C Amp. (Telephony) Class-C Amp. Plate-Mod.	1250	-175	150	—	—	130	248B 348B	
																					1000
249C	100	10	3.25	1250	150	50	12.5	6.1	13.0	4.7	4-pin J.	M	Class-C Amp. (Telephony) Class-C Amp. Plate-Mod.	1250	-175	150	—	—	130	249C	
																					1000
261A 361A	100	10	3.25	1250	150	50	12	6.5	9.0	4.0	4-pin J.	M	Class-C Amp. (Telephony) Class-C Amp. Plate-Mod.	1250	-175	125	—	—	100	261A 361A	
																					1000
276A 376A	100	10	3.0	1250	125	50	12	6.0	9.0	4.0	4-pin J.	M	Class-C Amp. (Telephony) Class-C Amp. Plate-Mod.	1250	-175	125	—	—	100	276A 376A	
																					1000
284B	100	10	3.25	1250	150	100	5.0	4.2	7.4	5.3	4-pin J.	M	Class-C Amp. (Telephony) Class-C Amp. Plate-Mod.	1250	-430	150	—	—	100	284B	
																					1000
295A	100	10	3.25	1250	175	50	25	6.5	14.5	5.5	4-pin J.	M	Class-C Amp. (Telephony) Class-C Amp. Plate-Mod.	1250	-125	150	—	—	125	295A	
																					1000
838 938	100	10	3.25	1250	175	70	—	6.5	8.0	5.0	4-pin J.	M	Class-C Amp. (Telephony) Class-C Amp. Plate-Mod.	1250	-90	150	30	6.0	130	838 938	
																					1000
852	100	10	3.25	3000	150	40	12	1.9	2.6	1.0	4-pin M.	E	Class-C Amp. (Telephony) Class-C Amp. Plate-Mod.	3000	-600	85	15	12	165	852	
																					2000
8003	100	10	3.25	1500	250	50	12	5.8	11.7	3.4	4-pin J.	M	Class-C Amp.-Oscillator Class-C Amp. Plate-Mod.	1350	-180	245	35	11	250	8003	
																					1100
RK57/ 805	125	10	3.25	1500	210	70	—	6.5	8.0	5.0	4-pin J.	M	Class-C Amp. (Telephony) Class-B Amp. (Telephony)	1500	-105	200	40	8.5	915	RK57/ 805	
																					1250
T125	125	10	4.5	2500	250	60	25	6.3	6.0	1.3	4-pin J.	N	Class-C Amp. (Telephony) Class-C Amp. Plate-Mod.	2500	-200	240	31	11	475	T125	
																					2000
GL146	125	10	3.25	1500	200	60	78	7.2	9.2	3.9	4-pin GL	MM	Class-C Amp.-Oscillator Class-C Amp. Plate-Mod.	1250	-150	180	30	10	350	GL146	
																					1000
GL152	125	10	3.25	1500	200	60	25	7.0	8.8	4.0	4-pin GL	MM	Class-C Amp.-Oscillator Class-C Amp. Plate-Mod.	1250	-150	180	30	—	150	GL152	
																					1000
				1250	-40	132															

TABLE XIV — TRIODE TRANSMITTING TUBES — Continued

Type	Cathode		Max. Plate Dissipation on Watts	Max. Plate Current Ma.	Max. D.C. Grid Current Ma.	Amp. Factor	Interelectrode Capacitances (p.f.d.)			Base ²	Socket Connections ¹	Typical Operation	Plate Voltage	Grid Voltage	Plate Current Ma.	D.C. Grid Current Ma.	Approx. Grid Driving Power Watts ³	Approx. Carrier Output Power Watts	Type
	Volts	Amps.					Grid to Fil.	Grid to Plate	Plate to Fil.										
805 905	10	3.25	125	200	60	40/60	8.4	7.7	1.3	4-pin J.	M ⁴	1750	-115	200	40	8.0	240	805 905	
150T	5.0	10	150	200	50	13	3.0	3.5	0.5	4-pin J.	N	3000	-10	115	15	7.5	57.5	150T	
TW150	10	4.1	150	200	60	35	3.9	2.0	0.8	4-pin J.	N	3000	-170	200	35	17	470	TW150	
152TL *	5/10 ¹⁵	13/6.5	150	500	75	10	—	5.0	—	Special	NN	3000	-260	165	40	17	400	152TL	
HF200 HV18	10-11	3.4	150	200	50	18	5.2	5.8	1.2	4-pin J.	N	2500	-300	200	18	8.0	380	HF200 HV18	
HD203A	10	4.0	150	250	60	25	—	12	—	4-pin J.	M ⁴	2500	-140	90	—	4.0	80	HD203A	
HK354	5.0	10	150	300	50	14	4.5	3.8	1.1	4-pin J.	N	4000	-690	245	50	48	830	HK354	
HK354C	5.0	10	150	300	50	14	4.5	3.8	1.1	4-pin J.	N	3000	-550	210	50	35	525	HK354C	
HK354D	5.0	10	150	300	55	22	4.5	3.8	1.1	4-pin J.	N	3500	-400	240	50	38	690	HK354D	
HK354E	5.0	10	150	300	60	35	4.5	3.8	1.1	4-pin J.	N	3500	-448	240	55	36	525	HK354E	
HK354F	5.0	10	150	300	75	50	4.5	3.8	1.1	4-pin J.	N	3500	-368	250	75	50	720	HK354F	
810 ⁹	10	4.5	150	275	70	35	8.7	4.8	12	4-pin J.	M	1800	-160	275	40	12	475	810	
RK63	5.0	10	300	250	60	37	2.7	3.3	1.1	4-pin J.	N	2500	-150	100	50	12	100	RK63	
T200	10	5.75	300	350	80	16	9.5	7.9	1.6	4-pin J.	N	2500	-280	350	54	25	685	T200	
HF300	11-12	4.0	300	275	60	23	6.0	6.5	1.4	4-pin J.	N	3000	-400	250	36	17	385	HF300	
T814 HV12	10	4.0	300	200	60	12	8.5	12.8	1.7	4-pin J.	M ⁴	2500	-100	300	30	10	575	T814 HV12	
T822 HV27	10	4.0	300	300	60	27	8.5	13.5	2.1	4-pin J.	M ⁴	2500	-175	300	50	15	585	T822 HV27	

TABLE XIV — TRIODE TRANSMITTING TUBES — Continued

Type	Max. Plate Dissipation Watts	Cathode		Max. Plate Voltage	Max. Plate Current Ma.	Max. D.C. Grid Current Ma.	Amp. Factor	Interelectrode Capacitances (puf.)		Base ¹	Socket Connections ¹	Typical Operation	Plate Voltage	Grid Voltage	Plate Current Ma.	D.C. Grid Current Ma.	Approx. Grid Driving Power Watts ²	Approx. Carrier Output Power Watts	Type	
		Volts	Amps.					Grid to Fil.	Grid to Plate											Plate to Fil.
806 ¹	225	5.0	10	3300	300	50	12.6	6.6	4.2	1.1	4-pin J.	N	3300	-600	300	40	34	780	806 ¹	
250TH	250	5.0	10.5	3000	350	100	32	3.5	3.3	0.3	4-pin J.	N	3000	-210	330	75	42	750	250TH	
																				3000
250TL	250	5.0	10.5	3000	350	50	13	3.0	3.5	0.5	4-pin J.	N	3000	-600	330	45	42	750	250TL	
																				3000
GL159	250	10	9.6	2000	400	100	20	11	17.6	5.0	4-pin GL	MM	2000	-900	400	17	6.0	520	GL159	
																				1500
GL169	250	10	9.6	2000	400	100	85	11.5	19	4.7	4-pin GL	MM	2000	-100	400	42	10	620	GL169	
																				1500
204A 304A	250	11	3.85	2500	275	80	23	12.5	15	2.3	Special	Q	2000	-250	350	35	20	350	204A 304A	
																				2500
3088	250	14	4.0	2250	325	75	8.0	13.6	17.4	9.3	4-pin W.E.	AA	1750	-400	300	75	—	350	3088	
																				1750
219E 241B 319E	275	14	4.0	3000	350	75	16	14.9	18.8	8.6	4-pin W.E. 3-pin W.E.	AA BB	2000	-225	300	75	—	400	219E 241B 319E	
																				2000
300T ¹⁵ 304TL*	300	8.0	11.5	3500	350	75	16	4.0	4.0	0.6	4-pin J.	N	3500	-600	300	60	—	800	300T	
																				3000
HK654	300	7.5	15	4000	600	100	22	6.2	5.5	1.5	4-pin J.	N	4000	-735	425	75	85	1400	HK654	
																				3000
833*	300	10	10	3000	500	75	35	12.3	6.3	8.5	Special	T	3000	-900	475	65	25	740	833	
																				2500
270A	350	10	4.0	3000	375	75	16	18	21	2.0	Special	Q	3000	-375	350	—	—	700	270A	
																				2250

TABLE XIV — TRIODE TRANSMITTING TUBES — Continued

Type	Max. Plate Dissipation Watts	Cathode		Max. Plate Voltage	Max. Plate Current Ma.	Max. D.C. Grid Current Ma.	Amp. Factor	Interelectrode Capacitances (μμfd.)		Base ²	Socket Connections ¹	Typical Operation	Plate Voltage	Grid Voltage	Plate Current Ma.	D.C. Grid Current Ma.	Approx. Grid Driving Power Watts ⁵	Approx. Carrier Output Power Watts	Type
		Volts	Amps.					Grid to Fil.	Plate to Plate										
849	400	11	5.0	2500	350	125	19	17	33.5	3.0	Q	Class-C Amp. (Telegraphy) Class-C Amp. (Telephony) Class-B Amp. (Telephony)	2500 2000 2000	-250 -300 -300	300 300 300	30 30 30	8.0 14 12	560 425 180	849
831	400	11	10	3500	350	75	14.5	3.8	4.0	1.4	R	Class-C Amp. (Telephony) Class-B Amp. (Telephony)	3000 3500	-500 -220	900 146	60 —	50 —	360 160	831

¹ Refer to Transmitting Tube Base Diagrams.
² M — medium; J — jumbo.
³ All wire leads. Ratings at 500 Mc.
⁴ Plate connection to top cap.
⁵ See Chapter Five for discussion of grid driving power.
⁶ At 240 Mc.
⁷ Twin triodes. Values correspond to left- and right-hand sections.
⁸ Twin triodes. Values for both sections, in push-pull.
⁹ Intermittent commercial and amateur service ratings.
¹⁰ Gaseous discharge tube for use on 110-volt d.c. Use 500-ohm resistor in series with No. 1 grid. Ionizing current, 150 to 250 ma.
¹¹ Twin triodes. Characteristics per section.
¹² Indicates that tube is especially suited for u.h.f. work.
¹³ Calculated at 33% efficiency for 100% modulation.
¹⁴ Grid connected to pins 2 and 3.
¹⁵ Instant heating filament for mobile use.
¹⁶ Multiple unit tube with dual filaments which can be connected in series or parallel.
¹⁷ Obsolete type.

TABLE XV — TETRODE AND PENTODE TRANSMITTING TUBES

Type	Max. Plate Dissipation Watts	Cathode		Max. Plate Voltage	Max. Screen Voltage	Max. Screen Dissipation Watts	Interelectrode Capacitances (μμfd.)		Base ²	Socket Connections ¹	Typical Operation	Plate Voltage	Screen Voltage	Suppressor Voltage	Grid Voltage	Plate Current Ma.	Screen Current Ma.	Grid Current Ma.	Screen Resistor Ohms	Approx. Grid Driving Power Watts	Approx. Carrier Output Power Watts	Type
		Volts	Amps.				Grid to Fil.	Plate to Plate														
RK64	6.0	6.3	0.5	400	100	3.0	10	0.4	9.0	5-pin M.	H	Class-C Amp. (Telegraphy) Class-C Amp. (Telephony) Grid-Modulated Amp.	400 300 400	100 — 100	30 30 30	35 26 16	10 8.0 1.0	3.0 4.0 0.5	— 30000 —	0.18 0.2 0.16	10 6.0 2.5	RK64
1610	6.0	2.5	1.75	400	200	2.0	8.6	1.2	13	5-pin M.	FF	Suppressor-Mod. Amp. Class-C Amp. (Telegraphy) Class-C Amp. (Telephony)	400 400 400	150 — —	— — —	10 10 10	3.5 7.0 1.5	— — —	35000 — —	0.18 0.1 0.1	3.0 5.0 12.5	1610
RK56	8.0	6.3	0.55	300	300	4.5	10	0.2	9.0	5-pin M.	H	Class-C Amp. (Telegraphy) Class-C Amp. (Telephony) Grid-Modulated Amp.	350 300 300	300 — —	— — —	10 10 10	1.6 1.6 2.0	2800 — —	0.28 — —	8.5 — —	3.0	RK56
RK93 RK95 RK95B ¹⁸ RK45 ¹⁸	10	6.3	0.9	500	250	8	10	0.2	10	7-pin M.	G	Class-C Amp. (Telegraphy) Class-C Amp. (Telephony) Suppressor-Modulated Amp. Grid-Modulated Amplifier	500 400 500 500	45 — — 45	45 — — 45	38 31 39 40	4.0 4.0 4.0 4.0	4.0 8300 — —	0.5 0.8 1.3 1.3	22 13.5 6.0 6.5	92 92 6.0 6.5	RK93 RK95 RK95B RK45
1613	10	6.3	0.7	350	275	2.5	8.5	0.5	11.5	7-pin O.	GG	Class-C Amp. (Telegraphy) Class-C Amp. (Telephony) Class-C Amp. (Telephony) Class-C Amp. (Telephony)	350 275 200 200	— — — —	— — — —	30 42 15 15	3.5 2.8 4.0 4.0	20000 10000 9000 10000	0.22 0.16 0.4 0.4	9 6.0 92 92	1613	
837 RK44 ¹⁸	12	12.6	0.7	500	300	8	16	0.2	10	7-pin M.	G	Class-C Amp. (Telegraphy) Class-C Amp. (Telephony) Suppressor-Modulated Amp. Grid-Modulated Amplifier	500 400 500 500	140 — — —	40 — — —	45 30 23 6.0	5.0 5.0 3.5 0	13000 14000 14000 —	0.3 0.1 0.15 —	11 5.0 5.5 —	837 RK44	

TABLE XV — TETRODE AND PENTODE TRANSMITTING TUBES — Continued

Type	Cathode		Max. Plate Dissipation Watts	Max. Plate Voltage	Max. Screen Voltage	Max. Screen Dissipation Watts	Interelectrode Capacitances (p.f.d.)		Base ²	Socket Connections ¹	Typical Operation	Plate Voltage	Screen Voltage	Suppressor Voltage	Grid Voltage	Plate Current Ma.	Screen Current Ma.	Grid Current Ma.	Screen Resistor Ohms	Approx. Grid Driving Power Watts	Approx. Carrier Output Power Watts	Type	
	Volts	Amps.					Grid to Fil.	Plate to Fil.															
802 ⁸	13	6.3 0.9	600	250	6.0	12	0.15	8.5	7-pin M.	G	Class-C Amp. (Telegraphy) Class-C Amp. Plate-Mod. Grid-Modulated Amp. Suppressor-Mod. Amp.	600 500 600 600	945 250 250 250	40 40 0 -45	-120 -40 -130 -100	55 40 30 30	16 15 8.0 24	2.4 1.5 1.0 5.0	— — — —	0.30 0.10 0.8 0.6	2.3 1.2 6.0 6.3	802	
HY60	15	6.3 0.5	425	200	2.5	11	0.19	10.2	5-pin M.	H	Class-C Amp. (Telegraphy) Class-C Amp. Plate-Mod. Grid-Modulated Amp.	425 325 425	200 200 200	— — —	-62.5 -45 —	60 60 55	7.0 8.5 7.0	3.0 2.5 —	— — —	0.25 0.2 —	1.7 1.0 8.0 ⁹	HY60	
306A	15	2.75 2.0	300	300	6.0	13	0.35	13	5-pin M.	EE	Class-C Amp. (Telephony)	300	180	—	-50	36	15	3.0	8000	—	—	7.0	306A
307A	15	5.5 1.0	500	250	6	15	0.55	12	5-pin M.	J	Class-C Amp. (Telephony) Suppressor-Modulated Amp.	500 500	250 300	0 -50	-35 -35	60 40	13 90	1.4 1.5	30000 14000	—	—	9.0	307A
832	15	6.3 0.8	400	250	5	7.5	0.05	3.8	Special	U	Class-C Amp. (Telephony) Grid-Modulated Amplifier	400 400	250 250	— —	-60 -60	90 55	18 6.0	0.3 0	8300 —	0.18 0.1	2.2 7.6	832	
844	15	2.5 2.5	500	180	3	9.5	0.15	7.5	5-pin M.	H	Class-C Amp. (Telephony)	500	175	—	-125	25	5.0	—	—	—	—	9.0	844
865	15	7.5 2.0	750	175	3	8.5	0.1	8.0	4-pin M.	I	Class-C Amp. (Telephony)	500	150	—	-100	20	—	—	—	—	—	4.0	865
1619	15	2.5 2.0	400	300	3.5	10.5	0.35	12.5	7-pin O.	7AC ¹⁰	Class-C Amp. (Telephony) Class-C Amp. Plate-Mod. Grid-Modulated Amplifier	400 325 400	300 285 250	— — —	-55 -50 -50	75 62 31	10.5 7.5 1.5	5.0 2.8 1.2	— — —	0.36 0.18 0.25	19.5 1.3 3.8	1619	
254A	20	5.0 3.95	750	175	5	4.6	0.1	9.4	4-pin M.	I	Class-C Amplifier	750	175	—	-90	60	—	—	—	—	—	9.5	254A
T21	21	6.3 0.9	400	300	3.5	13	0.7	12	6-pin M.	HH	Class-C Amp. (Telephony) Class-C Amp. Plate-Mod. Grid-Modulated Amp.	400 350 400	250 300 250	— — —	-45 -40 -40	95 65 55	8.0 17 8.0	3.0 5.0 4.0	— — —	0.2 0.35 0.25	2.5 1.4 2.5	T21	
RK49	21	6.3 0.9	400	300	3.5	11.5	1.4	10.6	6-pin M.	6A ¹⁰	Class-C Amp. (Telephony) Grid-Modulated Amplifier	400 300	250 200	— —	-50 -45	95 60	3.0 15	3.0 4.0	— 6700	0.2 0.34	2.5 1.2	RK49	
6L6	21	6.3 0.9	375	300	3.5	13	0.5	12.5	7-pin O.	7AC ¹⁰	Class-C Amp.-Oscillator Class-C Amp.-Mod.	375 300	250 250	— —	-35 -50	88 90	3.5 2.0	— —	— —	0.18 0.25	1.7 3.0	6L6	
6L6GX	21	6.3 0.9	500	300	3.5	11	1.5	7.0	7-pin O.	7AC ¹⁰	Class-C Amp. Plate-Mod. Grid-Modulated Amp.	500 500	325 250	— —	-45 —	90 65	3.0 9.0	3.0 —	— —	0.25 —	3.0 11 ⁹	6L6GX	
1614	21	6.3 0.9	375	300	3.5	13	0.5	12.5	7-pin O.	7AC ¹⁰	Class-C Amp. (Telegraphy) Class-C Amp. Plate-Mod. ⁵	375 325	300 —	— —	-35 -70	88 65	3.5 9.0	3.5 9.0	— —	0.18 0.8	1.7 11	1614	
RK41	25	2.5 2.4	600	300	3.5	13	0.2	10	5-pin M.	H	Class-C Amp. (Telephony)	600	300	—	-90	93	10	3.0	—	—	0.38	3.6	RK41
RK39	25	6.3 0.9	600	300	3.5	13	0.2	10	5-pin M.	H	Class-C Amp. (Telephony) Grid-Modulated Amplifier	475 600	300 300	— —	-50 -70	85 60	9.0 3.0	9.5 0.2	25000 —	0.2 0.54	2.6 1.2	RK39	
HY61/807	25	6.3 0.9	600	300	3.5	11	0.2	7.0	5-pin M.	H	Class-C Amp. (Telephony) Class-C Amp. (Telephony) Grid-Modulated Amplifier	600 475 600	250 250 250	— — —	-50 -50 -50	100 83 63	9.0 9.0 9.0	3.0 2.0 2.0	39000 25000 —	0.22 0.13 —	37.5 2.4 12.5	HY61/ 807	

TABLE XV — TETRODE AND PENTODE TRANSMITTING TUBES — Continued

Type	Cathode		Max. Plate Dissipation Watts	Max. Screen Voltage	Max. Screen Dissipation Watts	Inter-electrode Capacitances (p.f.d.)		Base ²	Socket Connections ¹	Typical Operation	Plate Voltage	Screen Voltage	Sup-pressor Voltage	Grid Voltage	Plate Current Ma.	Screen Current Ma.	Grid Current Ma.	Screen Resistor Ohms	Approx. Grid Driving Power Watts	Approx. Carrier Output Power Watts	Type
	Max. Plate Dissipation Watts	Volts Amps.				Grid to Fil.	Grid to Plate														
*815 ¹⁴	25	6.3 1.6	500	200	4.0	13.3	0.2 ¹⁵	8.5	8-pin O.	KK	500	200	—	-45	150	17	2.5	—	0.13	56	815
254B	25	7.5 3.25	750	150	5.0	11.2	0.085	5.4	4-pin M.	I	500	175	—	-135	75	3.0	0.4	—	0.28	13	254B
1624	25	2.5 2.0	600	300	3.5	11	0.25	7.5	5-pin M.	J ¹²	600	300	—	-50	75	9.0	3.3	—	0.43	35	1624
RK66	30	6.3 1.5	600	300	3.5	12	0.25	10.5	5-pin M.	L	600	300	—	-60	90	11	5.0	25000	0.23	25	RK66
807 ⁸	30	6.3 0.9	750	300	3.5	11	0.2	7.0	5-pin M.	H	600	275	—	-78	100	9.0	3.0	—	0.22	50	807
RK90	40	7.5 3.0	1950	300	15	14	0.01	12	5-pin M.	J	1000	300	—	-100	75	30	10	23000	1.3	52	RK90
RK30A		7.5 2.95									1250	300	—	-100	48	44	11.5	—	1.5	21	RK30A
RK46 ¹⁸		12.0 2.5									1250	300	45	-142	40	7.0	1.8	—	1.5	20	RK46
HY69 ¹⁶	40	6.3 1.5	600	250	5.0	7.0	0.25	6.0	5-pin M.	J ¹¹	600	250	—	-60	100	12.5	5.0	30000	0.35	42	HY69
899* ¹⁴	40	6.3 2.25	500	225	40	15.2	0.1 ¹⁶	6.5	7-pin S.	U	500	200	—	-45	240	32	12	—	0.7	83	899
RK47	50	10 3.25	1950	300	10	13	0.12	10	5-pin M.	J ⁴	1250	300	—	-38	120	10	2.0	—	0.5	23	RK47
312A	50	10 2.8	1950	500	20	15.5	0.15	12.3	6-pin M.	II	1250	300	—	-150	120	17.5	6.0	—	1.4	87	312A
804 ⁸	50	7.5 3.0	1500	300	15	16	0.01	14.5	5-pin M.	J	1500	300	—	-30	60	2.0	0.9	—	4.0	25	804
895* ¹⁷	50	6.3 0.75	2000	3600	—	3.4	—	—	Special	OO	1500	3600	800	-115	50	32	7.0	—	0.95	28	895
305A	60	10 3.1	1000	200	6	10.5	0.14	5.4	4-pin M.	A ³	1000	200	—	-270	125	—	—	—	—	85	305A
814 ⁸	65	10 3.25	1500	300	10	13.5	0.1	13.5	5-pin M.	J ¹	1500	300	—	-90	150	24	10	—	1.5	160	814
282A	70	10 3.0	1000	250	5.0	12.2	0.2	6.8	4-pin M.	I	1500	250	—	-160	100	60	3.0	—	4.2	35	282A

TABLE XVI — TELEVISION TRANSMITTING TUBES

Type	Name	Socket Connections ¹	Heater		Use	Collector Voltage	Pattern Electrode Voltage	Anode No. 2 Voltage	Anode No. 1 Voltage	Cut-off Grid Voltage ²	Signal Plate Voltage	Collector Current μ a. ³	Beam Current μ a.	Pattern Electrode Current ⁴	Signal Plate Input	Beam ⁵ Resolution Capability	Signal Output Volts	Type	
			Volts	Amps.															
1847	Iconoscope	A	6.3	0.6	Direct pickup	600	—	600	150	-120	—	—	—	—	—	—	—	1847	
1849	Iconoscope	J	6.3	0.6	Film pickup	1200	—	1200	450	-30	—	0.25	—	—	—	—	—	1849	
1850	Iconoscope	J	6.3	0.6	Direct pickup	1000	—	1000	360	-25	—	0.1	—	—	—	—	—	1850	
Same as 1849																			
1898	Monoscope	E	2.5	2.1	Test pattern	—	1150	1200	360	-70	—	—	1.0	1.0	—	—	—	—	1898
1899	Monoscope	K	2.5	2.1	Test pattern	1700	750	800	240	-50	—	—	3.0	3.0	—	—	—	—	1899
						1050	1000	1500	390	-60	—	—	4.0	2.5	—	—	—	—	
2203	Monotron	L	2.5	2.1	Test pattern	—	—	1000	400	-80	-150	—	—	—	5	300	0.1	2203	

¹ Refer to Cathode Ray Tube Socket Connections.

² Adjust bias for minimum (most negative) value for satisfactory signal. Maximum resistance in grid circuit should not exceed 1 meg.

³ Collector current measurements made with mosaic not illuminated.

⁴ Peak-to-peak signal value in μ a.

⁵ in mw./sq. cm. max.

⁶ With full scanning.

Antenna Fundamentals

Wave Propagation — The Half-Wave Antenna — Radiation — Reflection from the Ground — Directional Characteristics

Too often an amateur erects an antenna system without a clear understanding of the characteristics possessed by the particular type chosen and, consequently, with little regard for the all-important question of whether or not those characteristics are suited to the purpose for which the antenna is intended. Before one can select the right tool for a job he must know what that job is. The antenna's job is that of radiating electro-magnetic waves in such a way that they will reach a desired receiving point with maximum intensity. Obviously, then, we must know something about the nature of radio waves and how they travel before we can consider how most effectively to start them on their way.

● THE NATURE OF RADIO WAVES

Radio waves are of the same nature as light waves, traveling with the same velocity of 186,000 miles or 300,000 kilometers per second. They are **electro-magnetic** waves, having an electric component and an accompanying magnetic component, the two being at right angles to each other in space. The waves are **plane waves** and the plane of the electric and magnetic components is always at right angles to the line along which the waves are traveling. The wave is said to be **vertically polarized** when it travels with its electric component perpendicular to the earth, and is said to be **horizontally polarized** when the electric component is parallel to the earth. The polarization at transmission will correspond to the position of the antenna which radiates the waves, vertical or horizontal, although the polarization may shift as the wave travels through space or encounters incidental conductors in its path. The polarization of the waves at the receiving point is of practical importance because the voltage induced in the receiving antenna will be greatest when the antenna is placed to suit the particular polarization of the wave — vertical for vertically-polarized waves and horizontal for horizontally-polarized waves.

Radio waves, like light waves, can be **reflected** and **refracted**. Reflection occurs when the wave strikes a conductor, such as a wire. A current is set up in the wire, and in turn

causes the wire to radiate an electro-magnetic wave of its own. Reflection also can occur in the upper atmosphere, as described in the following paragraphs.

The Ionosphere

Radio waves not only travel along the surface of the earth in the lower atmosphere, for short-distance communication; they also travel through the upper regions far above the earth for long-distance communication.

The general idea of the paths followed by radio waves for both direct-ray and indirect-ray communication is illustrated in Fig. 2101-A. As would be expected, a direct ray travels out from the transmitter along the

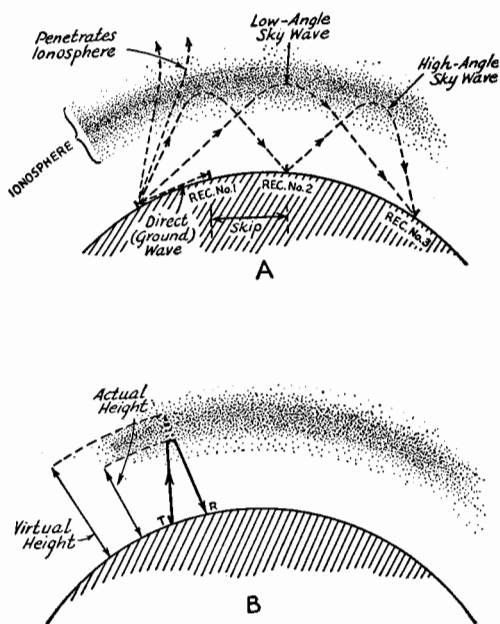

Fig. 2101 — Illustrating ground-wave and sky-wave transmission of radio waves. The density of the dots indicates that the electron density in the ionosphere increases and then decreases as the altitude becomes greater. This is a simplified representation; actually there are other ionized layers which affect different frequencies in different ways.

Antenna Fundamentals

surface of the earth and will be received strongly at a relatively near-by point. This part of the radiation is commonly called the **ground wave**. It is rapidly weakened or **attenuated** as it progresses, until finally it is no longer of useful strength. Moreover, the rapidity with which the ground wave is attenuated is greater as its frequency is higher (or as its wavelength is shorter).

But not all the energy radiated by the antenna is in waves along the surface. The greater part is likely to be at angles considerably above the horizontal, in fact. These higher-angle **sky waves** would travel on outward into space indefinitely, and would be of no practical use for communication, if they were not bent back to earth again. This bending action is explained by the existence of a region of ionized atmosphere, known as the **ionosphere**, surrounding the earth. The possibility of radio waves being returned from such an ionized region was proposed almost simultaneously by A. E. Kennelly in America and by Oliver Heaviside in England in 1902, many years before long-distance short-wave communication demonstrated its proof. In honor of these two scientists, the ionosphere has been long known also as the **Kennelly-Heaviside layer**. The ionosphere is not strictly a single layer, however. Dr. Kennelly suggested this in his original proposal and investigations have shown that there are several distinct layers, as will be explained in the following paragraphs.

How Sky Waves Are Bent by Refraction

The ionization of air molecules mentioned above is the result of bombardment by cosmic and solar radiation, breaking the molecules into free electrons and positive ions. This ionization is inappreciable in the air near the earth's surface, to which the ionizing radiations penetrate to only a slight extent, and in which the electrons and ions recombine so quickly as to permit the electrons practically no free path. It is considerable in the thin atmosphere at heights extending between approximately 40 and 250 miles (70 to 400 kilometers). It is the presence of the free electrons resulting from ionization in this region, and the relatively long free path there allowed the electron before recombination, which is principally responsible for bending of the sky waves.

For the amateur frequencies between 7000 kc. (40-meter band) and 30,000 kc. (10-meter band), the bending is practically all **refraction**. That is, a wave entering the increasingly ionized region from the lower atmosphere has its velocity increased by the increased conductivity due to the presence of the free electrons, and more or less gradually has its course turned away from the ionized region, back towards the earth. One way of visualizing

this is to consider the wave as two adjacent rays, one above the other. The upper ray travels faster than the lower ray as it progresses into the ionosphere because it is in the denser electron atmosphere. Hence, it tends to gain on the lower ray, with the consequence that the path of the wave is curved downward to earth — somewhat as the left wheel of a vehicle turning faster than the right will cause a change of direction to the right. A suggestion of this refracting action is given for sky waves in Fig. 2101.

Skip Distance and Layer Height

The sharpness with which this bending occurs is the greater as the frequency of the wave is lower. At 3500 kc. and lower frequencies the sky wave usually will return quite close to the transmitting point, within the range covered by the ground wave, as well as at greater distances. At 7000 kc., however, the sky wave often will not return this close to the transmitter, and there will be a zone of silence from the farther limit of the ground wave to the closest point at which the sky wave returns. This no-signal interval is known as the **skip distance**, from the fact that the signals seem to skip over. The skip distance increases with frequency, until at frequencies in the 28-Mc. band it becomes so great that the returning signal is likely to miss the earth and not to be heard under ionosphere conditions prevailing much of the time.

As shown by Fig. 2101-A, the bending at a given frequency is also determined by the angle at which the wave strikes the ionized region. Waves entering the ionosphere at grazing incidence are much more readily refracted than those which approach it nearly perpendicularly. At the higher frequencies, in fact, waves which strike the ionosphere at relatively high angles with respect to the horizon are not refracted sufficiently to be returned to earth, and hence are not useful for communication. Under all except very abnormal conditions, 56-Mc. waves, for instance, are not refracted by the ionosphere even though the angle is very low.

The degree of bending is a function of the intensity of ionization. This varies with the time of day, as the portion of the earth under consideration receives more or less radiation from the sun, so that transmission conditions go through daily cycles. The ionization also is influenced by cyclic changes in the condition of the sun itself, so that similar variations follow the 27-day and 11- or 22-year sun-spot activity cycles. The effect of the latter variations is more apparent on the higher frequencies — 14 and 28 Mc. — where conditions for refraction are most critical.

Measurements have shown that there are

The Radio Amateur's Handbook

three ionized regions or layers of a major nature, with others occasionally making an appearance. The three are called the *E* layer, the *F*₁ layer and the *F*₂ layer. Measurements made at Washington, D. C., by the U. S. Bureau of Standards show that the *E* layer has a virtual height of approximately 70 miles for the lower frequencies in this range during daytime. At mid-frequencies the waves penetrate this layer and are returned from the *F*₁ layer at a height of approximately 140 miles. At the higher frequencies the waves penetrate both the *E* and *F*₁ layers and are returned from the *F*₂ layer at a height of 200-250 miles. Towards evening the *F*₁ and *F*₂ layers appear to merge, leaving only the one layer in the *F* region at a virtual height of approximately 185 miles during the night.

The layer principally effective for long-distance communication at night is the *F* layer, while any one of the three may be effective for sky-wave transmission during the daytime, depending on the frequency and degree of ionization.

Ultra-High Frequency Waves

Although waves of ultra-high frequency (above 30 Mc.) are only rarely bent back to earth by the ionosphere, studies in reception of 56-Mc. transmissions over distances of 100 miles or so, which are greater than the ground wave or optical range, have shown evidence of bending in the lower atmosphere. Investigations by the A.R.R.L. technical staff during 1934 and 1935 showed that this bending accompanies the presence below 10,000-foot altitude of warmer air layers over cooler surface air; that is, it accompanies the occurrence of temperature inversions in the lower atmosphere. Apparently there is cause for sufficient refraction at 56 Mc., and at 112 Mc., to give "air-wave" communication at distances greater than would be possible with line-of-sight transmission.

Wave Propagation in Relation to Antenna Design

An important practical lesson to be learned from the peculiarities of radio wave travel is that transmission will be most effective when the energy radiated from the antenna is concentrated on the ionosphere at an angle which will put the best signal down at the receiving point. For long-distance communication this means that the maximum radiation should be more nearly horizontal than vertical; that is, **low-angle** radiation is desirable, especially on the 14- and 28-Mc. bands.

Available data indicate that under most conditions, 28-Mc. waves traveling at an angle of more than 15 degrees or so with the horizon seldom are returned to earth by the iono-

sphere; on the average, the optimum angle lies between 5 and 10 degrees. On 14 Mc. the normal upper limit is about 30 degrees, with angles up to 15 or 20 degrees being most effective. On 7 and 3.5 Mc. purely vertical radiation often is returned; angles up to at least 45 degrees are effective under most conditions on the former band, and to a still higher figure on the latter. In the discussion of antenna radiation characteristics in this chapter, angles of 9 degrees for 28 Mc., 15 degrees for 14 Mc., and 30 degrees for 7 and 3.5 Mc. have been assumed as representing average conditions for comparative purposes. Purely horizontal radiation over any considerable distance is practically unattainable at the higher frequencies because of rapid absorption of energy by the ground.

The question of polarization also deserves some consideration. Experimental data show that at 7 Mc. and higher the waves usually are horizontally polarized at the receiving point regardless of the polarization of the transmitting antenna. It is thought that this "ironing-out" of the polarization occurs when the wave is refracted in the ionosphere, perhaps also as the result of influence of the ground near the receiving antenna. On 3.5 Mc. the polarization is variable, and on 1.75 Mc. is chiefly vertical. The conclusion to be drawn is that on the 3.5-Mc. and higher-frequency bands little consideration need be given polarization at the *transmitting* antenna. For receiving, however, a horizontal antenna is preferable not only because it will give greatest output from the horizontally polarized waves, but also because most local electrical interference (from machines, automobile ignition, etc.) prevalent on the higher frequencies is vertically polarized, hence the response to such interference will be minimized. On 1.75 Mc. vertical polarization is to be preferred from the standpoint of effective transmission, but may lead to interference with near-by broadcast receivers, the antennas for which also respond well to vertically-polarized waves.

● THE HALF-WAVE ANTENNA

The fundamental form of antenna, and the one in widest practical use for short-wave work, is a single wire whose length is approximately equal to half the transmitting wave-length. It

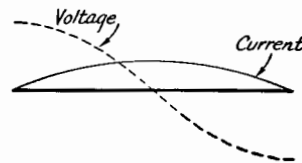

Fig. 2102 — Current and voltage distribution on a half-wave antenna.

Antenna Fundamentals

is important to understand its properties because the half-wave antenna is the unit from which many more complex forms of antennas are constructed. It is sometimes known as a **Hertz** or **doublet** antenna.

It was explained in Chapter 3 that when power is fed to such an antenna the current and voltage vary along its length. The distribution, which is practically the form of a sine curve, is shown in Fig. 2102. The current is maximum at the center (a point of maximum is known as a **loop** or **antinode**) and nearly zero at the ends, while the opposite is true of the r.f. voltage. The current does not actually reach zero at the current **nodes**, or minimum points, because of the effect of capacitance at the ends of the wire (**end effect**); similarly, the voltage is not zero at its node because of the resistance of the antenna, which consists of both the r.f. resistance of the wire (**ohmic resistance**) and the **radiation resistance**. Usually the ohmic resistance of a half-wave antenna is small enough, in comparison with the radiation resistance, to be neglected for all practical purposes. Radiation resistance has been defined in Chapter 3.

Antenna Impedance

The radiation resistance of a half-wave antenna in free space — that is, sufficiently removed from surrounding objects so that they do not affect the antenna's characteristics — is 73 ohms, approximately. The value under practical conditions will vary with the height of the antenna, but is commonly taken to be in the neighborhood of 70 ohms. It is pure resistance, and is measured at the center of the antenna. The antenna impedance at any point will be equal to the voltage divided by the current at the point. The impedance is minimum at the center, where it is equal to the radiation resistance, and increases toward the ends. The end value will depend on a number of factors such as the height, physical construction, and the position with respect to ground (horizontal or vertical).

The impedance is an important quantity which must be taken into account when methods of feeding power to the antenna are under consideration.

Physical Length

The length of a half-wave in space is

$$\text{length (feet)} = \frac{492}{\text{Freq. (Mc.)}} \quad (1)$$

The actual length of a half-wave antenna will not be exactly equal to the half wavelength in space but is usually about 5% less, because of end effects. The reduction factor increases slightly as the frequency is increased. Under average conditions, the following for-

mula will give the length of a half-wave antenna to sufficient accuracy:

$$\text{Length of half-wave antenna (feet)} = \frac{492 \times 0.95}{\text{Freq. (Mc.)}} = \frac{468}{\text{Freq. (Mc.)}} \quad (2)$$

Differences of a few per cent in length will make no appreciable difference in the radiation characteristics of the antenna, but may have an effect on the operation of the feeder system used. This will be considered in Chapter 22.

Radiation Characteristics

The radiation from a half-wave antenna is not uniform in all directions but varies with

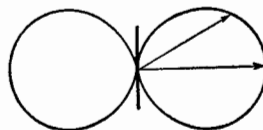

Fig. 2103 — Free-space radiation pattern of half-wave antenna. The antenna is shown in the vertical position. This is a cross-section of the solid pattern described by the figure when rotated on its axis (the antenna). The "doughnut" form of the solid pattern can easily be visualized by imagining the drawing glued to cardboard, with a short length of wire fastened on to represent the antenna. Then twirling the wire will give a visual representation of the solid pattern.

the angle with respect to the axis of the wire. It is most intense in directions at right-angles to the wire, and zero along the direction of the wire itself, with intermediate values at intermediate angles. This is shown by the sketch of Fig. 2103, which represents the radiation pattern in free space. The relative intensity of radiation is proportional to the length of a line drawn from the center of the figure to the perimeter. If the antenna is vertical, as shown in the figure, then the **field strength**, the measure of signal intensity, will be uniform in all horizontal directions; if the antenna is horizontal, the relative field strength will depend upon the direction of the receiving point with respect to the direction of the antenna wire.

● GROUND EFFECTS

When the antenna is near the ground, as all amateur antennas are, the free-space pattern of Fig. 2103 is modified by reflection of radiated waves from the ground, so that the actual pattern is the resultant of the free-space pattern and ground reflections. This resultant is dependent upon the height of the antenna and its position or orientation with respect to the surface of the ground. The reflected waves may be in such phase relationship to the directly-radiated waves that the two completely reinforce each other, or the phase relationship may be such that complete cancellation takes place. All intermediate values

The Radio Amateur's Handbook

also are possible. In other words, the effect of a perfectly-reflecting ground is such that the original free-space field strength may be multiplied by a factor which has a maximum value of 2, for complete reinforcement, and having all intermediate values to zero, for complete cancellation. Since waves are always reflected upward from the ground (assuming that the surface is fairly level) these reflections only affect the radiation pattern in the vertical plane — that is, in directions upward from the earth's surface — and not in the horizontal plane, or the usual geographical directions.

Fig. 2104 shows how the multiplying factor varies with the vertical angle for several representative heights for horizontal antennas. The maximum value (2) comes at a vertical angle of 90 degrees (directly upward) for an antenna height of $\frac{1}{4}$ wavelength. As the height is increased the angle at which complete reinforcement takes place is lowered until it occurs at a vertical angle of 15 degrees for a height equal to one wavelength. Note that the factor is zero for an angle of 30 degrees when the antenna is one wavelength high, is zero at slightly over 40 degrees for a height of $\frac{3}{4}$ wavelength, and is zero at 90 degrees for a height of $\frac{1}{2}$ wavelength. This means that there can be no radiation at these vertical angles for the heights given, from a horizontal antenna above perfectly-conducting ground.

We have already seen that the vertical angle, or "angle of radiation" is of primary importance, especially at the higher frequencies. It is therefore advantageous to erect the antenna at a height which will take advantage of ground reflection in such a way as to reinforce the space radiation at the most desirable angle. Generally speaking, this simply means that

the antenna should be high; at least $\frac{1}{2}$ wavelength at 14 Mc. and preferably $\frac{3}{4}$ or 1 wavelength; at least 1 wavelength and preferably higher at 28 Mc. Fortunately the actual height decreases as the frequency is increased so that good heights are not impracticable; a half wavelength at 14 Mc. is only 35 feet, approximately, and the same height represents a full wavelength at 28 Mc. At 7 Mc. and lower, the higher radiation angles are effective so that again a reasonable antenna height is not difficult of attainment. Heights between 35 and 70 feet are suitable for all bands, the higher figures being preferable if circumstances permit their use.

When the half-wave antenna is vertical the maximum and minimum points in the curves of Fig. 2104 exchange positions, so that the nulls become maxima, and vice versa. In this case, the height is taken as the distance from ground to the center of the antenna.

Fig. 2104 is based on a ground having perfect conductivity, a thing which is not met with in practice. The principal effect of actual ground is to make the curves inaccurate at the lowest angles; appreciable high-frequency radiation at angles smaller than about 5 degrees is practically impossible to obtain. Above 15 degrees, however, the curves are accurate enough for all practical purposes, and may be taken as indicative of the sort of result to be expected at angles between 5 and 15 degrees.

The effective ground plane — that is, the plane from which ground reflections can be considered to take place — seldom is the actual surface of the ground but is a few feet below it, depending upon the character of the soil.

Vertical or Horizontal?

Although polarization is generally unimportant in high-frequency communication, the question of whether the antenna should be installed in a horizontal or vertical position deserves consideration on other counts. A vertical half-wave antenna will radiate equally well in all *horizontal* directions, so that it is substantially non-directional in the usual sense of the word. If installed horizontally, however, the antenna will tend to show directional effects, and will radiate best in the direction at right-angles, or broadside, to the wire. The radiation in such a case will be least in the direction toward which the wire points. This can be seen readily by imagining that Fig. 2103 is lying on the ground and that the pattern is looked at from above.

The vertical angle of radiation also will be affected by the position of the antenna. If it were not for ground losses at high frequencies, the vertical half-wave antenna would be preferred because it would concentrate the radiation horizontally. Practically, this the-

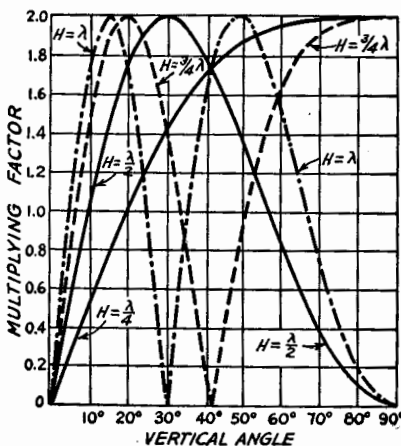

Fig. 2104 — Effect of ground on radiation at vertical angles for four antenna heights. This chart applies only to horizontal antennas, and is based on perfectly conducting ground.

Antenna Fundamentals

oretical advantage over the horizontal antenna is of little or no consequence; in fact, at certain heights the vertical antenna may actually not be as good a low-angle radiator as the horizontal since, as previously explained, the positions of the maxima and minima of Fig. 2104 are interchanged when the antenna is vertical.

For the same pole height, a horizontal antenna usually will be more "in the clear" than a vertical, so that energy losses in near-by objects usually will be less. The horizontal position is desirable if the antenna is used for receiving, as previously explained. Also, the horizontally-polarized transmissions are less likely to cause interference with near-by broadcast receivers.

Effective Radiation Patterns

In determining the effective radiation pattern of an antenna it is necessary to consider radiation in both the horizontal and vertical planes. When the half-wave antenna is vertical, the vertical angle of radiation chosen does not affect the *shape* of the horizontal pattern, but only its relative amplitude. When the antenna is horizontal, however, both the shape and amplitude are dependent upon the angle of radiation chosen.

Fig. 2105 should make this clear. The "free-space" pattern of the horizontal antenna shown is a section cut vertically through the solid pattern. In the direction *OA*, horizontally along the wire axis, the radiation is zero. At some vertical angle represented by the line *OB*, however, the radiation is appreciable, despite the fact that this line runs in the same geographical direction as *OA*. At some higher angle *OC* the radiation, still in the same geographical direction, is still more intense. The effective radiation pattern therefore depends upon the angle of radiation most useful. The factors influencing the selection of these angles were considered earlier in this chapter. It must be remembered, however, that they represent only average or near-average conditions, and that the effective pattern is dependent upon the conditions existing in the ionosphere. These conditions may vary not only from day to day and hour to hour, but even from minute to minute. Obviously, then, the effective directivity of the antenna will change along with transmission conditions.

Fig. 2105 — Illustrating the importance of vertical-angle of radiation in determining antenna directional effects. Ground reflection is neglected in this drawing. As previously explained, reflection from the ground will reinforce or cancel radiation at certain vertical angles, depending upon the height.

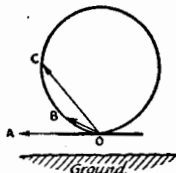

Theoretical horizontal-directivity patterns for half-wave horizontal antennas at vertical angles of 9, 15 and 30 degrees are given in Fig. 2106. At intermediate angles the values in the affected regions also will be intermediate. Relative field strengths are plotted on a decibel scale (see Chapter 20) so that they represent as nearly as possible the actual aural effect at the receiving station. If the signal in the direction of maximum intensity is S9, the smallest value on the scale should be about S1.

The considerations discussed here in connec-

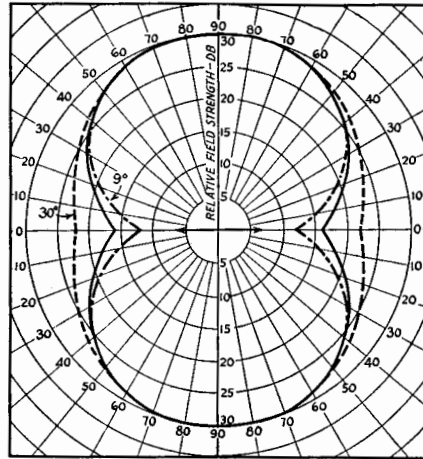

Fig. 2106 — Horizontal pattern of a horizontal half-wave antenna at three vertical radiation angles. Solid line is relative radiation at 15 degrees. Dotted lines show deviation from the 15-degree pattern, for angles of 9 and 30 degrees. The patterns are useful for shape only, since the amplitude will depend upon the height of the antenna above ground and the vertical angle considered. The patterns for all three angles have been proportioned to the same scale, but this does not mean that the maximum amplitudes necessarily are the same. The arrow indicates the direction of the antenna wire.

tion with half-wave antennas also apply to the more complicated types described later.

● GROUNDED ANTENNAS

The grounded antenna is used almost exclusively for 1.75-Mc. work, where the length required for a half-wave antenna would be excessive for most locations. An antenna worked "against ground" need be only a quarter-wave long, approximately, because the earth acts as an electrical "mirror" which supplies the missing quarter wave. The current at the ground connection with a quarter-wave antenna is maximum, just as it is at the center of a half-wave antenna.

On 1.75 Mc. the most useful radiation is from the vertical part of the antenna, since vertically-polarized waves are characteristic of ground-wave transmission. It is therefore de-

The Radio Amateur's Handbook

sirable to make the down-lead as nearly vertical as possible, and also as high as possible. This gives low-angle sky-wave transmission which is most useful for long-distance work at night, in addition to a good ground wave for local work. The horizontal portion contributes to high-angle sky-wave transmission, which is useful for covering short distances on this band at night.

Fig. 2107 shows a grounded antenna with the top folded to make the length equal to a quarter wave. The antenna coupling apparatus consists of the coil L , tuned by the series condenser C , with L inductively coupled to the transmitter tank circuit.

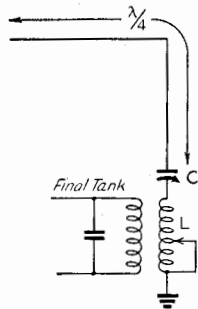

Fig. 2107—Typical grounded antenna, consisting of a vertical section and horizontal section having a total length (including the ground lead if the latter is more than a few feet long) of one-quarter wavelength. Coil L should have about 20 turns of No. 12 on a three-inch diameter form, tapped every two or three turns for adjustment. C is 250 to 500 $\mu\text{mfd.}$ variable. The inductive coupling between L and the final tank coil should be variable.

For computation purposes, the *overall* length of a grounded system is given by

$$L \text{ (feet)} = \frac{236}{f \text{ (Mc.)}}$$

This length, it should be noted, is the *total* length from the far end of the antenna to the

ground connection. The length is not critical, since departures of the order of 10% to 20% can be compensated by the tuning apparatus.

The ground should preferably be one with conductors buried deep enough to reach natural moisture. In urban locations, good grounds can be made to water mains where they enter the house; the pipe should be scraped clean and a low-resistance connection made with a tightly-fastened ground clamp. If no water-pipes are available several pipes, six to eight feet long, may be driven into the ground at intervals of six or eight feet, all being connected together. The transmitter should be located so as to make the ground lead as short as possible.

In locations where it is impossible to secure a good ground connection because of sandy soil or other considerations, it is preferable to substitute a counterpoise for the ground connection. The counterpoise consists of a system of wires insulated from ground running horizontally above the earth beneath the antenna. The counterpoise should have a sufficient number of wires of sufficient length to cover well the area immediately under the antenna. The wires may be formed into any convenient shape, i.e., they may be spread out fan-shape, in a radial pattern, or three or more parallel wires separated a few feet running beneath the antenna may be used. The counterpoise should be elevated six or seven feet above the ground so it will not interfere with persons walking under it. Connection is made between the usual ground terminal of the transmitter and each of the wires in the counterpoise.

R. F. Transmission Lines

Types of Lines — Matching to the Antenna — Coupling to the Transmitter

POWER may be applied to the antenna either directly or through a transmission line. Three methods of direct excitation are shown in Fig. 2201. In *A* the antenna is cut at the center and a small coil inserted. The coil is coupled to the output tank circuit of the transmitter, with adjustable coupling so that the transmitter loading can be controlled. Since the addition of the coil "loads" the antenna, or increases its effective length because of the additional inductance, the series condensers C_1 and C_2 are put in the circuit to provide electrical means for reducing the length to its original unloaded value. This method of feeding is known as **current feed**, because power is inserted at a high-current point.

The methods of *B* and *C* are called **voltage-feed** systems because the power is introduced into the antenna at a point of high voltage. In *B* the end of the antenna is coupled to the output tank circuit through a small condenser; in *C* a separate tank, connected directly to the antenna, is used. This tank is tuned to the transmitter frequency and may be grounded at one end or at the center of the coil, as shown. Practical considerations and methods of ad-

justment of all three systems will be discussed in a later section.

Direct excitation is seldom used except on the lowest amateur frequencies. It involves bringing the antenna proper into the operating room and hence into close relationship with the house and electric wiring, which usually means that some of the power is wasted in heating poor conductors in the field of the antenna. Also, it usually means that the shape of the antenna must be distorted so that the expected directional effects are not realized, and likewise means that the height is limited. For these reasons, in high-frequency work practically all amateurs use transmission lines or feeder systems which permit putting the antenna in a desirable location. The feeders do not radiate or dissipate themselves any substantial proportion of the power supplied by the transmitter, provided good design practice is followed.

● TRANSMISSION LINES

A transmission line is used to transfer power, with a minimum of loss, from its source to the device in which the power is to be usefully expended. At radio frequencies, where every wire carrying r.f. current tends to radiate energy in the form of electro-magnetic waves, special design is necessary to minimize radiation and thus cause as much as possible of the power to be delivered to the receiving end of the line.

Radiation can be minimized by using a line in which the current is low, and by using two conductors carrying currents of equal magnitudes but opposite phase so that the fields about the conductors cancel each other. For good cancellation of radiation the two conductors should be parallel and quite close to each other.

The most common form of transmission line consists of two parallel wires, maintained at a fixed spacing of two to six inches by insulating spacers or spreaders at suitable intervals (**open-wire line**). A second type consists of rubber-insulated wires twisted together to form a flexible line without spacers (**twisted-pair line**). A third uses a wire inside and coaxial with a tubing outer conductor, separated from the

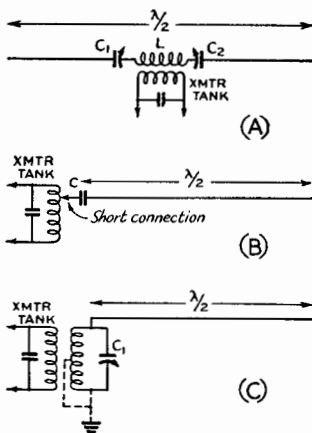

Fig. 2201 — Methods of direct feed to the half-wave antenna. *A*, current feed, series tuning; *B*, voltage feed, capacity coupling; *C*, voltage feed with inductively coupled antenna tank. In *A*, the coupling apparatus is not included in the antenna length.

The Radio Amateur's Handbook

outer conductor by insulating spacers or "beads" at regular intervals (**coaxial** or **concentric line**). A variation of this type uses solid rubber insulation between the inner and outer conductors, the latter usually being made of braid rather than solid tubing so that the line will be flexible. Still another type of line uses a single wire alone, without a second conductor (**single-wire feeder**); in this case radiation is minimized by keeping the line current low.

Line Operation

The length of transmission lines used at radio frequencies is of the same order as the length of the antenna, and therefore the current and voltage along the line may not be as uniform at all points as it would be on, say, a 60-cycle power line. In other words, standing waves of current and voltage may appear on the line. Standing waves occur when some of the energy fed into the line by the transmitter is reflected back from the opposite or termination end of the line, which is the point where the line attaches to the antenna in the transmitting case.

The **standing-wave ratio** — that is, the ratio of current or voltage at a loop to the value at a node — depends upon the resistance at the receiving end of the line, or **termination**, and the **characteristic** or **surge impedance** of the line itself. The characteristic impedance of the line is equal to the square root of the ratio of inductance to capacity of the line per unit length. The standing-wave ratio is the ratio between the line impedance and the terminating resistance; that is,

$$\text{Standing-wave ratio} = \frac{Z_o}{Z_t} \text{ or } \frac{Z_t}{Z_o}$$

where Z_o is the characteristic impedance of the line and Z_t is the terminating resistance, Z_t is generally called an impedance, although it must be non-reactive and therefore correspond to a pure resistance for the line to operate as described. This means that the load or termination, when an antenna, must be resonant at the operating frequency.

The formula is given in two ways because it is customary to put the larger number in the numerator so that the ratio will not be fractional. As an example, a 600-ohm line terminated in a resistance of 70 ohms will have a standing wave ratio of 600/70, or 8.57. The ratio on a 70-ohm line terminated in a resistance of 600 ohms would be the same. This means that if the current as measured at a node, or minimum point, along the line is 0.1 amp., the current at a maximum or loop will be 0.857 amp.

When the line is terminated in a resistance equal to its characteristic impedance, there is no reflection and consequently no standing

waves appear, as explained in Chapter 3. The standing wave ratio therefore is 1. Such a line is said to be **non-resonant** or **flat**, and may be made any convenient length. For any given length of line, the losses, both by heat and by radiation, will be minimum when the line is non-resonant. The input end of such a line appears to the transmitter as a pure resistance of a value equal to the characteristic impedance of the line.

When the standing wave ratio on the line is appreciable the line is said to be **resonant**. Unless the line is exactly the right length to contain a whole standing wave (on the total length of both conductors) or some integral multiple of such a length, the input end of the line will be reactive as well as resistive. To make the line take maximum power with a given degree of coupling, the reactive component must be cancelled out by tuning. Such lines are therefore known as **tuned lines**. The losses in a line having standing waves will increase with the standing-wave ratio. With air-insulated lines, the loss does not represent a considerable fraction of the input power unless the line is exceptionally long; with lengths up to a few wave-lengths the increase in loss with standing-wave ratios as high as 10 to 1 is not appreciable when the line is air-insulated. With lines using solid dielectrics the loss increases at a much higher rate, and such lines should always be operated non-resonant.

Characteristic Impedance

The characteristic impedance of air-insulated transmission lines may be calculated from the following formulas:

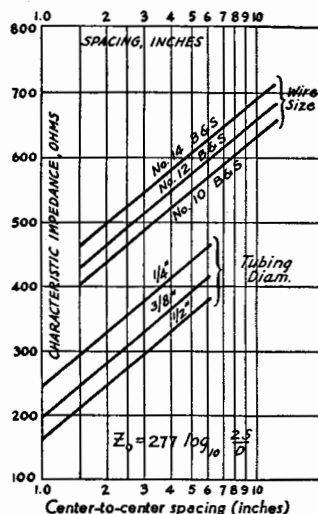

Fig. 2202 — Graphical table of characteristic impedances of typical spaced-conductor transmission lines. Use outside diameter of tubing.

R. F. Transmission Lines

Parallel-conductor line

$$Z = 276 \log \frac{b}{a} \quad (1)$$

where Z is the surge impedance, b the spacing, center to center, and a the radius of the conductor. The quantities b and a must be measured in the same units (inches, etc.). Surge impedance as a function of spacing for lines using conductors of different size is plotted in chart form in Fig. 2202.

Coaxial or concentric line

$$Z = 138 \log \frac{b}{a} \quad (2)$$

where Z again is the surge impedance. In this case, however, b is the *inside diameter* (not radius) of the outer conductor and a is the *outside diameter* of the inner conductor. The formula is true for air dielectric, and approximately so for a line having ceramic insulators so spaced that the major proportion of the insulation is air.

When a solid insulating material is used between the conductors the impedance decreases, because of the increase in line capacity, by the factor $1/\sqrt{k}$, where k is the dielectric constant of the insulating material.

The impedance of a single-wire transmission line varies with the size of the conductor, its height above ground, and orientation with respect to ground. An average figure is about 500 ohms.

Electrical length

The electrical length of a line is not exactly the same as its physical length for reasons corresponding to the end effects in antennas. Spacers used to separate the conductors have dielectric constants larger than that of air, so that the waves do not travel quite as fast along a line as they would in air. The lengths of electrical quarter waves of various types of lines can be calculated from the formula

$$\text{Length (feet)} = \frac{246 \times V}{\text{Freq. (Mc.)}} \quad (3)$$

where V depends upon the type of line. For lines of ordinary construction, V is as follows:

Parallel wire line	$V = 0.975$
Parallel tubing line	$V = 0.95$
Concentric line (air-insulated)	$V = 0.85$
Concentric line (rubber-insulated)	$V = 0.56-0.65$
Twisted pair	

Line Spacing

For effective cancellation of radiation, the spacing between the two wires must be small

in comparison to the wavelength; a separation of 0.01 wavelength or less is desirable. For 14 Mc. and lower, the wires need not be closer than six inches, the length of the popular "feeder spreaders" manufactured for this purpose. Even at 28 Mc. a separation of 6 inches is fairly satisfactory, but for the ultra-high frequencies the wires should be closer together.

From the practical standpoint, too-close spacing is undesirable, especially with long sections of line. The wires inevitably swing with respect to each other when there is wind; if the spacing is close, this means that insulating spreaders must be installed at frequent intervals to prevent the wires from touching, and this in turn increases the weight of the line. Swinging also causes a varying detuning effect, since the change in spacing represents a change in line constants which reacts on the transmitter, causing periodic variations in loading.

For work on communication frequencies, the 6-inch spacing for open lines represents a compromise which works out well in practice.

Line Losses

Air-insulated non-resonant lines operate at quite high efficiency. Parallel-conductor lines average 0.12 to 0.15 db loss per wavelength of line. These figures hold only if the standing wave ratio is 1. The losses increase with the standing-wave ratio, rather slowly up to a ratio of 15 to 1, but rapidly thereafter. For standing-wave ratios of 10 or 15 to 1 the increase is inconsequential.

Concentric lines with air insulation are excellent when dry, but losses increase if there is moisture in the line. Provision therefore should be made for making such lines airtight, and they should be thoroughly dry when assembled. This type of line has the least radiation loss. The small lines ($\frac{3}{8}$ -inch outer conductor) should not be used at high voltages, hence it is desirable to keep the standing-wave ratio down.

Good quality rubber insulated lines, both twisted pair and coaxial, average about 1 db loss per wavelength of line. At the higher frequencies, therefore, such lines should be used only in short lengths if losses are important. These lines have the advantages of compactness, ease of installation, and flexibility. Ordinary lampcord has a loss of approximately 1.4 db per wavelength, when dry, but its losses become excessive when wet. The parallel moulded-rubber type is best from the standpoint of withstanding wet weather. The characteristic impedance of lampcord is between 120 and 140 ohms.

The loss in db is directly proportional to the length of the line. Thus a line which has a loss of 1 db per wavelength will have an actual loss

The Radio Amateur's Handbook

of 3 db if the line is three wavelengths long. In the case of line losses, the length is not expressed in terms of electrical length but in physical length; that is, a wavelength of line, in feet, is equal to $984/\text{Freq. (Mc.)}$ for computing loss. This permits a direct comparison of lines having the same physical length. The electrical lengths, of course, may differ considerably.

● NON-RESONANT LINES

The several advantages of operating transmission lines non-resonant — minimum losses, and elimination of the necessity for tuning —

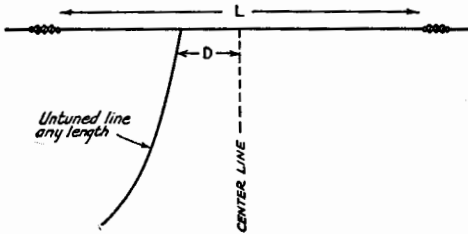

Fig. 2203 — Single-wire feed system. The length L (one-half wavelength) and D are determined from the chart, Fig. 2204.

make this type of line attractive. The chief disadvantage of the non-resonant line, aside from the necessity for more care in initial adjustment, is that when "matched" to the ordinary antenna it is matched only for one frequency, or at most for a small band of frequencies on either side of the frequency for which the matching is done. Except for a few special systems, this means that the antenna is unsuitable for work on more than one amateur band.

Adjustment of a non-resonant line is simply that of adjusting the terminating resistance to match the characteristic impedance of the line. To accomplish this, the antenna itself must be resonant at the selected frequency, and the line must then be connected to it in such a way that the antenna impedance as looked at by the line is the right value. The matching may be done by connecting the line at the proper spot along the antenna, or by inserting an impedance transforming device between the antenna and line.

In the following examples of ways in which different types of lines may be matched to the antenna, a half-wave antenna is used as an example. Other types of antennas may be treated by the same methods, making due allowance for the order of impedance that appears at the end of the line with more elaborate systems.

Fig. 2204 — Charts for determining the length of half-wave antennas for use on various amateur bands. Solid lines indicate antenna length (lower scale); dotted lines point of connection for single-wire feeder (upper scale) measured from center of antenna.

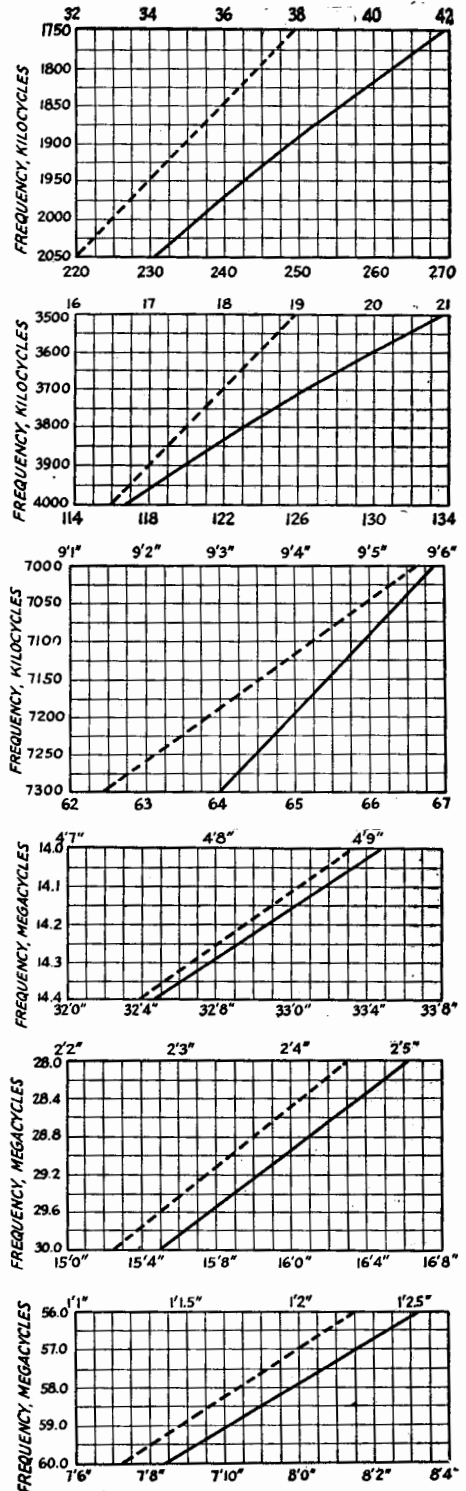

R. F. Transmission Lines

Single-Wire-Feed

In the single-wire-feed system the return circuit is considered to be through the ground. There will be no standing waves on the feeder

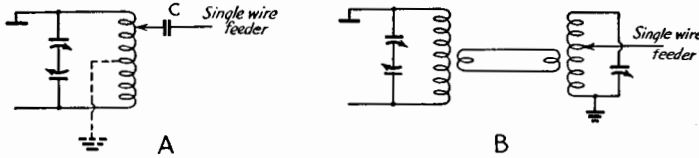

Fig. 2205 — Methods of coupling the single-wire feeder to the transmitter. Circuits are shown for both single-ended and balanced tank circuits. They are discussed in the text.

when its characteristic impedance is matched by the impedance of the antenna at the connection point. The principal dimensions are the length of the antenna L , Fig. 2203, and the distance D from the exact center of the antenna to the point at which the feeder is attached. Approximate dimensions can be obtained from Fig. 2204 for an antenna system having a fundamental frequency in any of the amateur bands.

In constructing an antenna system of this type the feeder must run straight away from the antenna (at a right angle) for a distance of at least one-third the length of the antenna. Otherwise the field of the antenna will affect the feeder and cause faulty operation. There should be no sharp bends in the feeder wire at any point.

Correct antenna length and placing of the feeder should be checked experimentally if best results are to be obtained. If, for instance, impedances are not correctly matched, standing waves will appear upon the line. With simple capacitive coupling to the feeder — as in Fig. 2205-A, high r.f. potentials may, as a result, develop at undesirable points in the transmitter. A good ground connection should be made to the filament center-tap or center point of the filament by-pass condensers when this system is used. The presence of standing waves may be detected most accurately by placing a low-reading thermo-ammeter at several points approximately $\frac{1}{4}$ wave apart along the transmission line. The reading should be substantially constant all along the line with no indication of pronounced increases or decreases.

With the coupling system shown in Fig. 2205-A, adjustment is as follows: Starting at the ground end of the tank coil, the tap is moved towards the plate end until the amplifier draws the rated amount of plate current. The plate tank condenser should be readjusted each time the tap is changed, to bring the plate current to minimum. The amplifier is loaded properly when this "minimum" is the rated current. The condenser in the feeder is for the purpose of insulating the antenna system from the high-voltage plate supply

when series plate feed is used. It should have a voltage rating somewhat above that of the plate supply. Almost any capacity greater than 500 $\mu\text{fd.}$ will be satisfactory. The condenser is unnecessary, of course, if parallel

plate feed is used. Several methods of inductive coupling to the output circuit are shown in Fig. 2205. In coupling to balanced output circuits, the method shown at the right is preferred. The antenna tank circuit should tune to resonance at the operating frequency and the loading is adjusted by varying the coupling between the two tanks, both being kept tuned to resonance. Or the feeder may be tapped on the antenna tank, when the tap is adjusted as explained previously. Regardless of the type of coupling, a good ground connection is essential with this system. Single-wire-feed systems work best over moist ground, and poorly over rock and sand.

Twisted-Pair Feed

It is evident from the formula for characteristic impedance previously given that the closer the spacing and the larger the wires, the lower will be the impedance. A two-wire line composed of twisted rubber-covered wire can be constructed to have an impedance approximately equal to that at the center of the antenna itself, thus permitting the method of connecting the line to the antenna shown in Fig. 2206. Such discrepancy as may exist between line and antenna impedance can be compensated for by a slight fanning of the line where it connects to the two halves of the antenna, as shown at B in Fig. 2206.

The twisted line is a convenient type to use,

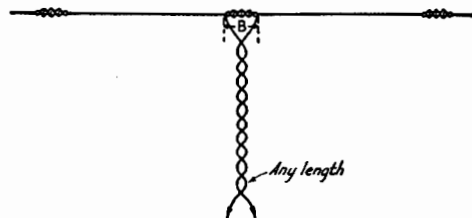

Fig. 2206 — A half-wave antenna center-fed by a twisted pair line. An improved impedance match often will result if the antenna end of the line is fanned out in the shape of a "V" for the last 18 inches or so of its length. Two insulators also should be used at the center of the antenna so the open end of the "V" will be approximately 18 inches wide. The antenna length (not including the center insulator) should equal one-half wavelength for the operating frequency. See Fig. 2204.

The Radio Amateur's Handbook

since it is easy to install and the r.f. voltage on it is low because of the low impedance. This makes insulation an easy matter. The losses are slightly higher than those in spaced lines with air insulation, however, and will increase with frequency. Special twisted line for transmitting purposes, having lower losses than ordinary rubber-covered wire, is available. It is known as "EO-1" cable.

The antenna should be one-half wavelength long for the frequency of operation, as determined by charts of Fig. 2204 or the formula given in Chapter 21. For accuracy, its length may be checked as described at the end of this chapter, this checking being done before the antenna is cut at the center to insert the feeder. The amount of "fanning" (dimension *B*) will depend upon the kind of cable used; the right value usually will be found between 6 and 18 inches. It may be checked by inserting ammeters in each antenna leg at the junction of the feeder and antenna; the value of *B* which gives the largest current is correct. Alternatively, the system may be operated continuously for a time with fairly high r.f. power input, after which the feeder may be inspected (by touch) for hot spots. These indicate the presence of standing waves, and the fanning should be adjusted until they are eliminated or minimized. Each leg of the feeder forming the triangle at the antenna should be equal in length to dimension *B*.

Methods of coupling to the transmitter are discussed later in connection with Fig. 2209.

Concentric Line Feed

A concentric transmission line readily can be constructed to have a surge impedance equal to the 70-ohm impedance at the center of a half-wave antenna. Such a line, therefore, can be connected directly to the center of the antenna, forming the system shown in Fig. 2207.

Solving Equation (2) for an air-insulated concentric line shows that, for 70-ohm surge impedance, the inside diameter of the outer conductor should be approximately 3.2 times the outside diameter of the inner conductor. This condition can be fulfilled by using stand-

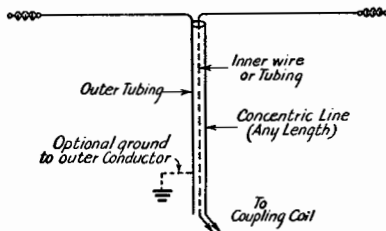

Fig. 2207—Half-wave antenna with concentric transmission line. The antenna length should be one-half wavelength as determined by the formula or Fig. 2204.

ard $\frac{5}{16}$ -inch (outside-diameter) copper tubing for the outer conductor and No. 14 wire for the inner. Ceramic insulating spacers are available commercially for this combination.

Also available is a rubber-insulated concentric line, with wire inner conductor and metal braid outer conductor, having the requisite impedance for connection to the center of the antenna. This type is more flexible and considerably lighter.

The operation of such an antenna system is

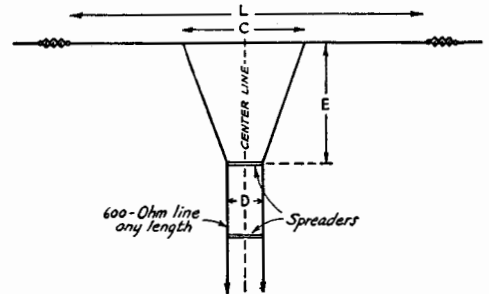

Fig. 2208—Two-wire matched-impedance antenna system. The dimensions *C*, *D*, and *E* are given in the text. It is important that the matching section, *E*, come straight away from the antenna without any bends.

L is one-half wavelength for the operating frequency.

similar to that of the twisted-pair system just described, and the same transmitter-coupling arrangements may be used. A simple form of coupling is shown in Fig. 2209, consisting of a loop of a few turns of wire placed around or near the transmitter tank coil. No tuning apparatus is required, the loading being adjusted by varying the coupling between the two coils.

The outer conductor of the line may be grounded if desired. The feeder system is slightly unbalanced because the inner and outer conductors do not have the same capacity to ground. There should be no radiation, however, from a line having the correct surge impedance.

Delta Matching Transformer

Because of the extremely close spacing required, it is impracticable to construct an open-wire transmission line which will have a surge impedance low enough to work directly into the center of a half-wave antenna. Such wire lines usually have impedances between 400 and 700 ohms, 600 ohms being a widely-used value. It is therefore necessary to use other means for matching the line to the antenna.

One method of matching is illustrated by the antenna system of Fig. 2208. The section *E* is "fanned" to have a gradually increasing impedance so that its impedance at the antenna end will be equal to the impedance of the an-

R. F. Transmission Lines

tenna section *C*, while the impedance at the lower end matches that of a practicable transmission line.

The antenna length *L*, the feeder clearance *E*, the spacing between centers of the feeder wires *D*, and the coupling length *C* are the important dimensions of this system. The system must be designed for exact impedance values as well as frequency values and the dimensions are therefore fairly critical.

The length of the antenna is figured from the formula or charts previously given.

The length of section *C* is computed by the formula:

$$C \text{ (feet)} = \frac{123}{\text{Freq. (Mc.)}}$$

The feeder clearance *E* is worked out from the equation:

$$E \text{ (feet)} = \frac{148}{\text{Freq. (Mc.)}}$$

The above equations are for feeders having a characteristic impedance of 600 ohms and will not apply to feeders of any other impedance. The proper feeder spacing for a 600-ohm transmission line is computed to a sufficiently close approximation by the following formula:

$$D = 75 \times d$$

where *D* is the distance between the centers of the feeder wires and *d* is the diameter of the wire. If the wire diameter is in inches the spacing will be in inches and if the wire diameter is

in millimeters the spacing will be in millimeters.

Methods of coupling to the transmitter are discussed in the following section.

Coupling to Untuned Lines

Similar coupling methods are used with all types of two-wire transmission lines, whether of high or low impedance. Several systems are shown in Fig. 2209. The inductively coupled methods are preferable to direct coupling when a single-ended or unbalanced tank circuit feeds a balanced transmission line; this avoids line unbalance which might occur with direct coupling. In the direct-coupled circuits, the fixed condensers are useful only when the output amplifier plate supply is series-fed. These condensers, when used, should have a rating somewhat above the maximum plate voltage used and should have a capacity of 500 $\mu\mu\text{fds}$. or more. With the methods *B*, *C*, *D* or *E*, the taps should be placed symmetrically about the center or r.f. ground point on the coil. The taps should be adjusted to make the final amplifier draw normal plate current; if the line is operating properly the taps will not affect the setting of the plate tank condenser. In the case of the methods shown at *B* and *D* the link coils may consist of a few turns each, and the coupling between one tank and link, preferably the antenna tank, should be variable. The antenna tank is first adjusted to resonance with the plate tank circuit, using loose coupling; the taps are then set at trial positions and the cur-

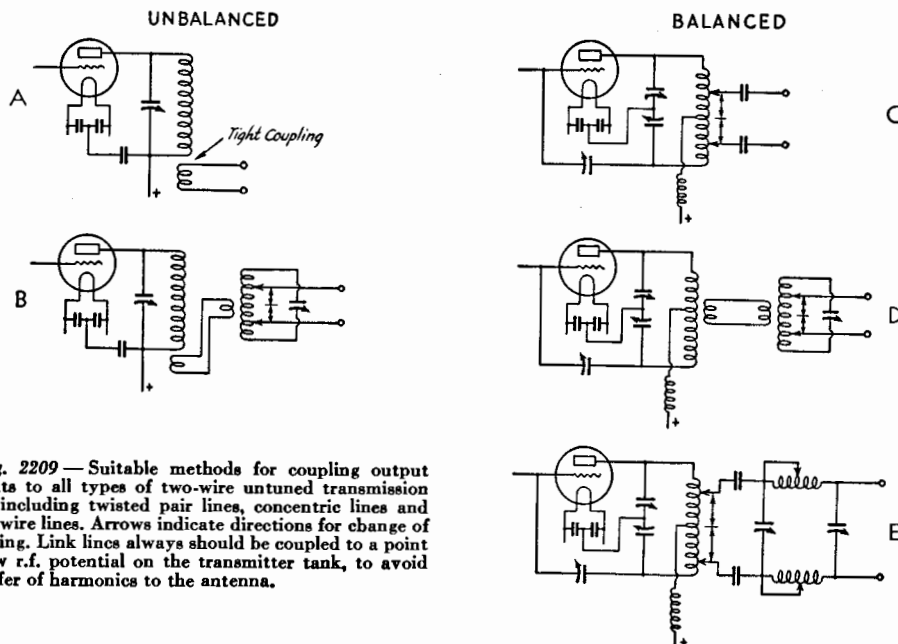

Fig. 2209 — Suitable methods for coupling output circuits to all types of two-wire untuned transmission lines including twisted pair lines, concentric lines and open wire lines. Arrows indicate directions for change of coupling. Link lines always should be coupled to a point of low r.f. potential on the transmitter tank, to avoid transfer of harmonics to the antenna.

The Radio Amateur's Handbook

rent in the line measured. The tap positions, coupling between the coils and tuning of both tank circuits are then adjusted to give maximum line current with normal tube plate current.

The network shown at *E* is described later in this chapter.

● LINEAR MATCHING SECTIONS

In the antenna-feeder systems just described, impedance matching depends upon connecting the line to an appropriate point on the antenna. An alternative method is to connect an impedance-matching transformer between the line and antenna when the line impedance is not the same as that at the center of the antenna. The "transformer" ordinarily used does not resemble the ordinary coupled r.f. circuit, but is simply a section of transmission line. A quarter-wave two-wire transmission line is such a "linear transformer."

When a quarter-wave line has a given value of impedance connected to one end, the impedance appearing at the other end depends upon the surge impedance of the line:

$$Z_1 = \frac{Z_s^2}{Z_2}$$

where Z_1 is the unknown impedance at one end, Z_2 the known impedance at the other end, and Z_s is the line surge impedance. At intermediate points on the line the impedance will be intermediate between the two end values. It is therefore possible to tap along the line to match a wide range of impedances, when the

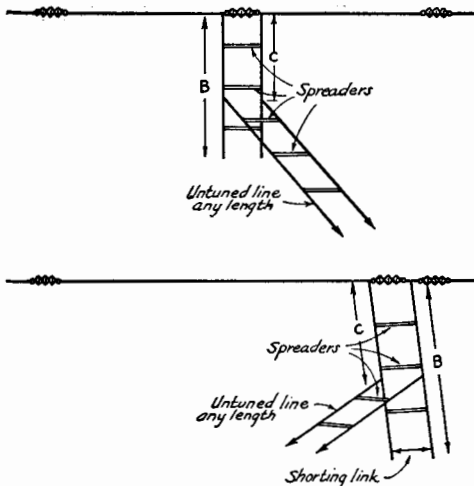

Fig. 2210 — Impedance-matching antenna systems with quarter-wave open wire matching transformers. Antenna dimensions can be found from Fig. 2204. The dimension *B*, one-quarter wavelength, can be found from Equation (3). The dimension *C* must be found by experiment, as described in the text.

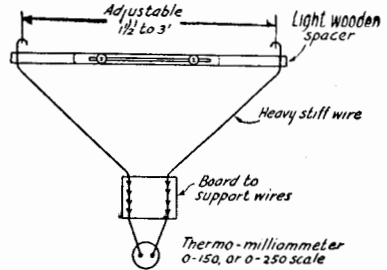

Fig. 2211 — Line-current measuring device for adjustment of untuned transmission lines.

quarter-wave "matching section" is connected to a high- or low-impedance point on the antenna.

Quarter-wave matching sections are particularly useful when a non-resonant line having a surge impedance of 600 ohms (a popular value) is to be matched to the antenna.

Fig. 2210 shows two methods of coupling a non-resonant line to a half-wave antenna through a quarter-wave matching section. In the case of the center-fed antenna the free end of the matching section, *B*, is open (high impedance) since the other end is connected to a low-impedance point on the antenna. With the end-fed antenna the free end of the matching section is closed through a shorting bar or link; this end has low impedance since the other end is connected to a high-impedance point on the antenna.

In the center-fed system, the antenna and matching section should be cut to the lengths found from the formulas previously given. Any necessary on-the-ground adjustment can be made by adding to or clipping off the open ends of the matching section. The matching section in the end-fed system can be adjusted by making the line a little longer than necessary and adjusting the system to resonance by moving the shorting link up and down. Resonance can be obtained by exciting the antenna from a temporary antenna nearby (the transmitter being on the proper frequency, of course) and measuring the current in the shorting bar by a low-range r.f. ammeter or galvanometer. The position of the bar should be adjusted for maximum current reading. This should be done before the untuned line is attached to the matching section.

The position of the line taps must be determined experimentally, since it will depend upon the impedance of the line as well as the antenna impedance at the point of connection. The procedure is to take a trial point, apply power to the transmitter, and check the non-resonant line for standing waves. This can be done by measuring the current in the wires, using a device of the type pictured in Fig. 2211. The hooks (which should be sharp

R. F. Transmission Lines

enough to cut through insulation, if any, of the wires) are placed on one of the wires, the spacing between them being adjusted to give a suitable reading on the meter. At any one position along the line the currents in the two wires should be identical. Readings taken at intervals of a quarter wavelength will indicate whether or not standing waves are present.

It will not usually be possible to obtain complete elimination of standing waves when the matching stub is exactly resonant. The line taps should be adjusted for the smallest standing-wave ratio, after the system is resonated as described above, that it is possible to obtain. Then a further "touching up" of the matching stub will eliminate the remaining standing wave, provided the adjustments are made carefully. The stub must be readjusted because when resonant it exhibits some reactance as well as resistance at all points except at the ends, and the slight lengthening or shortening of the stub is necessary to tune out this reactance. The required readjustment is quite small, however.

An impedance mismatch of several per cent is of little consequence so far as power transfer to the antenna is concerned. It is relatively easy to get the standing wave ratio down to 2 or 3 to 1, a perfectly satisfactory condition in practice. Of considerably greater importance is the necessity for getting the currents in the two wires balanced both as to amplitude and phase. If the currents are not the same at corresponding points on adjacent wires, and the loops and nodes do not also occur at corresponding points, there will be considerable radiation loss. This balance can only be brought about by perfect symmetry in the line, particularly with respect to ground. This symmetry should extend to the coupling apparatus at the transmitter. An electrostatic shield between the line and the transmitter coupling coils often will be of value in preventing capacity unbalance, and at the same time will reduce harmonic radiation.

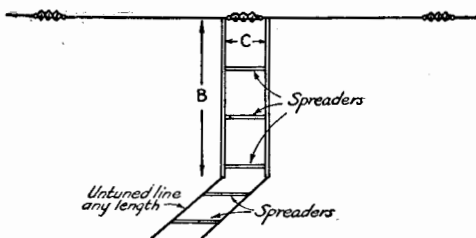

Fig. 2212 — The "Q" antenna with quarter-wave matching section using spaced tubing. Antenna length can be found from Fig. 2204. The matching section length, B , is given by Equation (3). The spacing, C , depends upon the impedance of the untuned line, and can be found from Fig. 2202 for a given size of tubing to make a line having surge impedance determined by Equation 4.

When the connection between matching section and antenna is unbalanced, as in the end-fed system, it is important that the antenna be the right length for the operating frequency if a good match is to be obtained. The balanced center-fed system is less critical in this respect. The shorting-bar method of tuning the center-fed system to resonance may be used if the matching section is extended to a half-wavelength, bringing a current loop at the free end.

The "Q" Antenna

The impedance of a two-wire line of ordinary construction (400 to 600 ohms) can be matched, without tapping, to the impedance of the center of a half-wave antenna by the use of a quarter-wave line of special characteristics. The matching section must have low surge impedance and therefore is commonly constructed of large-diameter conductors such as aluminum or copper tubing, with fairly close spacing. This type of antenna can be purchased in kit form and is known as the "Q" antenna. It is shown in Fig. 2212. The important dimensions are the length of the antenna, the length of the matching section, B , the spacing between the two conductors of the matching section, C , and the impedance of the untuned transmission line connected to the lower end of the matching section.

The required surge impedance for the matching section is

$$Z_s = \sqrt{Z_1 Z_2} \quad (4)$$

where the quantities are the same as previously given. A quarter-wave section matching a 600-ohm line to the center of a half-wave antenna (72 ohms), for example, should have a surge impedance of 208 ohms. The spacings between conductors of various sizes of tubing and wire for different surge impedances are given in graphical form in Fig. 2202. With half-inch tubing, for example, the spacing should be 1.5 inches for an impedance of 208 ohms.

The length, B , of the matching section should be equal to a quarter wavelength, and is given by

$$\text{Length of } \frac{1}{4} \text{ wave line (feet)} = \frac{234}{\text{Freq. (Mc.)}}$$

The length of the antenna can be calculated from the formula in Chapter 21 or taken from the charts of Fig. 2204.

This system has the advantage of the simplicity in adjustment of the twisted pair feeder system and at the same time the superior insulation of an open-wire system.

● THE RESONANT TWO-WIRE LINE

It is often helpful to look upon the resonant line simply as an antenna folded back on itself

The Radio Amateur's Handbook

so that the radiation from one half is cancelled by the out-of-phase radiation from the other half. Such a line may be any whole-number multiple of a quarter-wave in length; in other words any total wire length which will accommodate a whole number of standing waves. (The "length," however, of a two-wire line is always taken as the length of one of the wires.)

Quarter- and half-wave resonant lines are shown in Fig. 2213. The current distribution on both antenna and line is indicated. It will be noted that the quarter-wave line has maximum current at one end and minimum current at the other, determined by the point of connection to the antenna. The half-wave line, however, has the same current (and voltage) values at both ends; if the line is closed at one end, the current is maximum at both ends and the voltage minimum, while if both ends are open the current is minimum and the voltage maximum at the ends. The terms "open" and "closed" as used here do not mean necessarily that nothing is connected to the line, or that the line is short-circuited. Actually, of course, something must be connected to the line for it to function; the "open" end would be connected to a high-voltage low-current circuit and the "closed" end to a low-voltage high-current circuit.

If we connect a quarter-wave line to the end of an antenna as shown in Fig. 2213-A, then at the transmitter end of the line we have high current and low voltage, so that current feed (Fig. 2201-A) with a coil and series condensers (series tuning) can be used. Should the line be a half-wave long, as at 2213-B, current will be

minimum at the transmitter end of the line, just as it is at the end of the antenna. Voltage feed therefore is required and the parallel-resonant tuned circuit (Fig. 2201-C) (parallel tuning) must be used. The line could be coupled to a balanced final tank through small condensers, as in Fig. 2209-C, but the inductively-coupled circuit is preferable. An end-fed antenna with resonant feeders, as in 2213-A and B, is known as the "Zeppelin," or "Zepp," antenna.

The line also may be inserted at the center of the antenna at the maximum-current point. Quarter- and half-wave lines used in this way are shown at Fig. 2213-C and D. In C, the antenna end of the line is "closed," hence at the transmitter end the current is low and the voltage high. Parallel tuning therefore is used. The half-wave line at D has high current and low voltage at both ends, so that series tuning is used at the transmitter end.

A significant point to be noted is that the antenna determines the distribution of voltage and current. In Fig. 2213-C, for instance, series tuning (current feed to the feeders) cannot be used because there *must* be high current at the center of the half-wave antenna if it is to operate; consequently the voltage must be high at the transmitter end of the quarter-wave feeder. If we attempt to make this end of the feeder carry high current we should have to have high voltage at the center of the antenna. Logically it follows that, since each end of the antenna is one-quarter wave from the center, we should have to have high current at the antenna ends. This of course is impossible. If series tuning is used in the arrangement of Fig. 2213-C it will be found that the combination "will not tune"; in other words, the antenna will not take power from the transmitter.

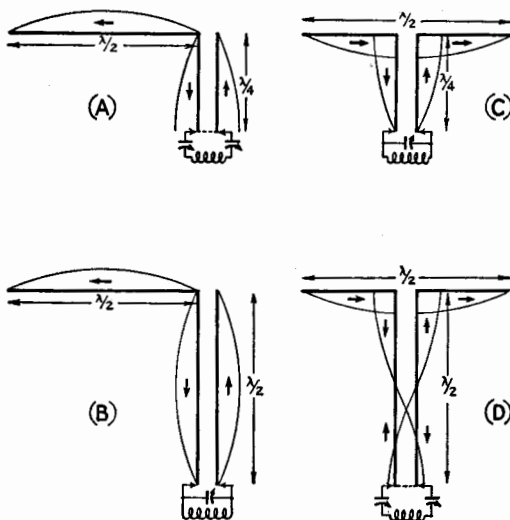

Fig. 2213 — Half-wave antennas fed from resonant lines. A and B, end feed with quarter- and half-wave lines; C and D, center feed. The current distribution is shown for all four cases.

Practical Antennas Using Resonant-Line Feed

The four arrangements shown in Fig. 2213 are thoroughly useful antenna systems, and are shown in more practical form in Fig. 2214. In each case the antenna is a half wavelength long, the exact length being calculated or taken from the charts of Fig. 2204. The line length should be an integral (whole number) multiple of a quarter wavelength, and may be calculated from Equation (3) the result being multiplied by any whole number which gives a total length convenient for reaching from the antenna to the transmitter. If there is an *odd* number of quarter waves on the line in the case of the end-fed antenna, series tuning will be used at the transmitter end; if an *even* number of quarter waves, then parallel tuning is used. With the center-fed antenna the reverse is true.

R. F. Transmission Lines

Tuning

The tuning procedure with series tuning is as follows: With C_1 and C_2 at minimum capacity, couple the antenna coil L_1 loosely to the transmitter output tank coil and observe the plate current. Then increase C_1 and C_2 simultaneously, until a setting is reached which gives maximum plate current, indicating that the antenna system is in resonance with the transmitting frequency. Readjust the plate tank condenser to minimum plate current. This is necessary because tuning the antenna circuit will have some effect on the tuning of the plate tank. The new minimum plate current will be higher than with the antenna system detuned, but should still be well below the rated value for the tube or tubes. Increase the coupling between L_1 and L_2 by a small amount, readjust C_1 and C_2 for maximum plate current, and again set the plate tank condenser to minimum. Continue this process until the minimum plate current is equal to the rated plate current for the amplifier. Always use the degree of coupling between L_1 and L_2 which will just bring the amplifier plate current to rated value when C_1 and C_2 pass through resonance. The r.f. ammeters should indicate maximum feeder current at the resonance setting; these meters are not strictly necessary, but are useful

in indicating the relative power output from the transmitter.

With parallel tuning the procedure is quite similar, except that only one antenna condenser is used. Find the value of coupling between L_1 and L_2 which will bring the plate current to the desired value as C_1 is tuned through resonance. Again a slight readjustment of the amplifier tank condenser may be necessary to compensate for the effect of coupling.

Feeder Current

The feeder current as read by the r.f. ammeters is useful for tuning purposes only; the absolute value is of little importance. When series tuning is used the current will be high, but very little current will be indicated in a parallel-tuned system. This is because of the current distribution on the feeders as shown by Fig. 2213. With a given antenna and tuning system, of course, the greatest power will be delivered to the antenna when the readings are highest. However, should the feeder length be changed no useful conclusions can be drawn from comparison between the new and old readings. For this reason any indicator which registers the relative intensity of r.f. current can be used for tuning purposes. Many amateurs, in fact, use flashlight or dial lamps for this purpose instead of meters. They are

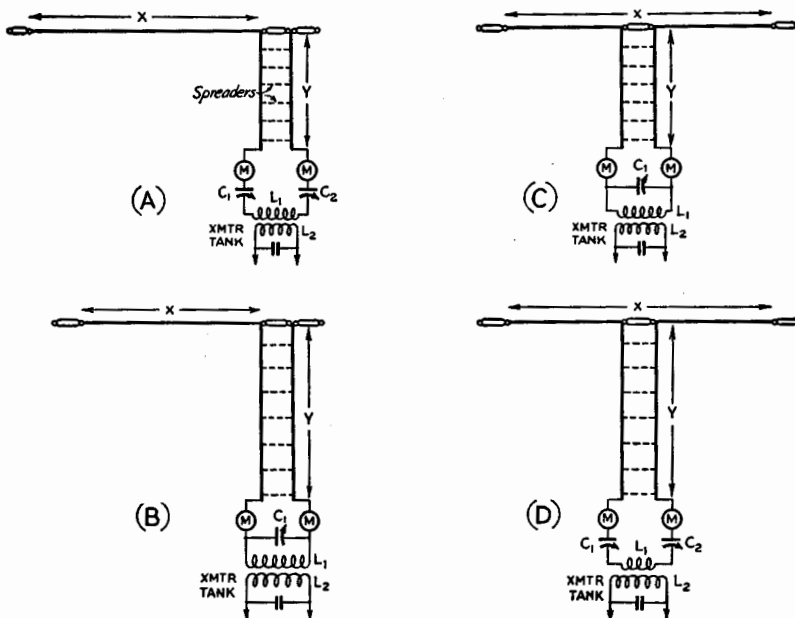

Fig. 2214 — Practical half-wave antenna systems using resonant-line feed. In the center-feed systems, the antenna length "X" does not include the length of the insulator at the center. Line length is measured from the antenna to the tuning apparatus; leads in the latter should be short enough to be neglected. The two meters shown are helpful for balancing feeder currents; however, one is sufficient for tuning for maximum output, and may be transferred from one feeder to the other, if desired. The systems at (A) and (C) are for feeders an odd number of quarter-waves in length; (B) and (D) for feeders a multiple of a half wavelength. The drawings correspond electrically to those of Fig. 2213.

The Radio Amateur's Handbook

cheap, and when shunted by short lengths of wire so that considerable current can be passed without burnout will serve very well even with high-power transmitters.

Circuit Values

The values of inductance and capacity to use in the antenna coupling system will depend upon the transmitting frequency, but are not particularly critical. With series tuning, the coil may consist of a few turns of the same construction as is used in the final tank; average values will run from two or three turns at 28 Mc. to perhaps 10 or 12 at 3.5 Mc. The number of turns preferably should be adjustable so that the inductance can be changed should it not be possible to reach resonance with the condensers used. The series condensers should have a maximum capacity of 250 or 350 $\mu\text{fd.}$ at the lower frequencies; the same values will serve even at 28 Mc., although 100 $\mu\text{fd.}$ will be ample for this and the 14-Mc. band. Since series tuning is used at a low-voltage point in the feeder system, the plate spacing of the condensers does not have to be large. Ordinary receiving-type condensers are large enough for plate voltages up to 1000, and the smaller transmitting condensers have high-enough voltage ratings for higher-power applications. With high-power 'phone it may be necessary to use condensers having a plate spacing of approximately 0.15 to 0.2 inch.

In parallel-tuned circuits the antenna coil and condenser should be approximately the same as those used in the final tank circuit. The antenna tank circuit must be capable of being tuned independently to the transmitting frequency, and if possible provision should be made for tapping the coil so that the L/C ratio can be varied to the optimum value as determined experimentally.

Alternative Coupling Circuits

The coupling arrangements in Fig. 2214 are simple and easy to adjust, but the antenna coil must be arranged so that its position with respect to the output tank coil can be changed. In practice, the antenna coil usually is mounted so that it can be moved toward or away from the final tank coil (the two coils being coaxial) on insulating bars or some other device which permits the coil to be slid back and forth. A swinging mount also can be used. These schemes are sometimes inconvenient for mechanical reasons.

Coupling circuits which do not involve moving coils — or at most only a variable link coil of the type now available on manufactured transmitting coils — are shown in Fig. 2215. At *A* is a link-coupled system with taps on the antenna coil for adjusting the loading. The link at the transmitter tank coil may consist of one

or two turns wound around the coil at a low-potential point. At the antenna circuit, the taps are kept equidistant from the center of the coil, the number of turns between taps being adjusted to give the desired plate current when the antenna-feeder system is tuned to resonance. The tap adjustment will be right when the antenna condenser or condensers bring the plate current to the desired value just as they are passing through resonance. The system may be used with either series or parallel tuning; the circuit values will be the same as with the inductively-coupled arrangements of Fig. 2214. When the coupling and tuning adjustments are correct there will be practically no detuning effect on the transmitter tank; that is, the resonance setting should be practically the same both with and without the link connected to *L*.

In *B*, link coupling is used at both ends, in which case the coupling between one coil and its link must be variable. Variable coupling at either end will be satisfactory. Swinging links

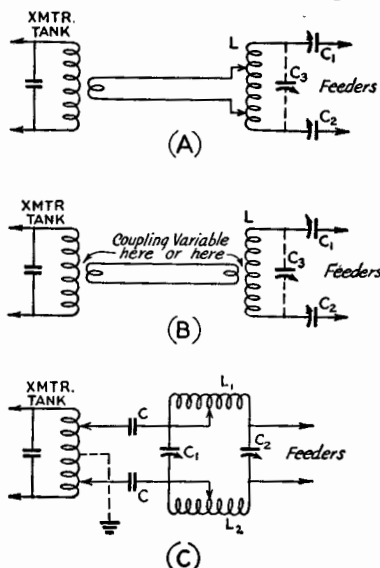

Fig. 2215 — Antenna coupling systems without movable coils. *A* and *B*, link-coupled circuits for series and parallel tuning; *C*, balanced low-pass filter. In *A* and *B*, dotted lines show connections for parallel tuning when called for; in such case the series condensers, C_1 and C_2 , may be set at maximum capacity or short-circuited. Constants for L , C_1 , C_2 and C_3 are the same as for inductive coupling, and are discussed in the text.

In *C*, C_1 and C_2 may be 100 to 250 $\mu\text{fd.}$ each, the higher-capacity values being used for lower-frequency operation (3.5 and 1.75 Mc.). Plate spacing should in general be at least half that of the final amplifier tank condenser. For operation from 1.75 to 14 Mc., L_1 and L_2 each should be 15 turns $2\frac{1}{2}$ inches in diameter, spaced to occupy 3 inches length, and tapped every three turns. Approximate settings are 15 turns for 1.75 Mc., 9 turns for 3.5 Mc., 6 turns for 7 Mc., and 3 turns for 14 Mc. The coils may be wound with No. 14 or No. 12 wire. See text for method of adjustment.

R. F. Transmission Lines

such as those shown in Chapter 10 may be used, or the link coil may be mounted inside the tank or antenna coil and arranged so that it may be rotated with respect to the coil. The adjustment method is the same as with the circuit of *A* except that the link position at the variable-coupling end is changed instead of the taps. Either series or parallel tuning again may be used.

Suitable link lines may be made from twisted rubber-covered pair, just as in the case of link-coupled stages in the transmitter. They may be of any convenient length, so that the antenna tuning unit may be mounted at the point where the feeders enter the building or operating room, if desired, regardless of the position of the transmitter.

A balanced pi-section coupling network is shown in Fig. 2215-C. This is a low-pass filter capable of coupling between a fairly wide range of impedances such as is encountered in going from series to parallel tuning. Suitable constants are given under the diagram. The method of adjustment is as follows: First, with the filter disconnected from the transmitter tank, tune the transmitter tank to resonance, as evidenced by minimum plate current. Then, with trial settings of the clips on L_1 and L_2 (few turns for high frequencies, more for lower) tap the input clips on the final tank coil at points equidistant from the center so that about half the coil is included between them. A balanced tank circuit must be used. Set C_2 at about half scale, apply power, and rapidly rotate C_1 until the plate current drops to minimum. If this minimum is not the desired full-load plate current, try a new setting of C_2 and repeat. If, for all settings of C_2 , the plate current is too high or too low, try new settings of the taps on L_1 and L_2 , and also on the transmitter tank. Do not touch the tank condenser during these adjustments. When, finally, the desired plate current is obtained, set C_1 carefully to the exact minimum plate-current point. *This adjustment is important in minimizing harmonic output.*

With some lengths of resonant lines, particularly those not exact multiples of a quarter wavelength, it may be difficult to get proper loading with the pi-section coupler. Usually, these lengths also will be difficult to feed with other systems of coupling. In such cases, the proper loading often can be obtained by varying the L/C ratio of the filter over a considerably wider range than is used for normal loads.

Feeder Lengths

The fact that the feeder-tuning apparatus makes it possible to vary the electrical length of the feeder obviates, to some extent, the necessity for cutting resonant feeders to exact integral multiples of a quarter wavelength.

It is, in fact, possible to depart as much as 25% of a quarter wave from the exact length and still tune the system properly. In such case, the type of tuning to use, series or parallel, will depend on whether the length of the feeder is nearer an odd number of quarter waves or nearer an even number.

Departure from the exact length is often convenient on the lower frequencies, where even a quarter-wave feeder may be physically longer than is desired. At 3500 kc., for example, a quarter-wave line is approximately 67 feet long. Its length could be reduced to 50 feet and still be made to resonate with series tuning by using a sufficiently large coupling coil. In such case the condensers might be shorted out and the tuning done by varying the coil inductance. Alternatively, a 100-foot line could be used on the same frequency by using a smaller coil and reduced series capacity.

Whenever possible, however, it is advisable to stick to the integral multiples of a quarter wavelength. This is the surest way of avoiding the tuning difficulties which often arise when the line is midway between lengths calling for series and parallel tuning.

Antenna Length in Relation to Feeder Operation

It has been previously pointed out that insofar as the operation of the antenna is concerned, departures of a few per cent from the exact length for resonance are of negligible consequence. Such inaccuracies may influence the behavior of the feeder system, however, and as a result may have an adverse effect on the operation of the system as a whole. This is true of the end-fed antennas such as are shown in Fig. 2214-A and -B.

For example, Fig. 2216-A shows the current distribution on the half-wave antenna and quarter-wave feeder when the antenna length is correct. At the junction of the "live" feeder and the antenna the current is minimum so that the currents in the two feeder wires are equal at all corresponding points along their length. When the antenna is too long, as in *B*, the current minimum occurs at a point on the antenna proper, so that at the top of the live feeder there is already appreciable current flowing, whereas at the top of the "dead" feeder the current must be zero. As a result, the feeder currents are not balanced and some power will be radiated from the line. In *C* the antenna is too short, bringing the current minimum to a point on the live feeder, so that again the currents are unbalanced. The more serious the unbalance the greater the radiation from the line.

Strictly speaking, a line having an unbalanced connection such as the one-way termination at the end of an antenna cannot be truly

The Radio Amateur's Handbook

balanced even though the antenna length is correct. This is because of the difference in loading on the two sides. The effect is fairly small, however, when the currents are balanced, and the illustration just given serves to emphasize the importance of correct antenna length.

If the antenna is fed at the center the undesirable effects of incorrect antenna length balance out so that the line operates properly under all conditions. This is shown in Fig. 2216 at *D*, *E* and *F*. So long as the two halves of the antenna are of equal length, the distribution of current on the feeders will be symmetrical so that no unbalance exists, even for antenna lengths considerably removed from the correct value.

The conditions illustrated in Fig. 2216 are also true for quarter- and half-wave matching sections of the type shown in Fig. 2210.

Adjusting the Antenna Length

Although the formula and charts for antenna length are sufficiently accurate under average conditions, height, nearness of the wire to houses, trees, etc., may make the required

actual length differ somewhat. When the antenna is to be end-fed, then, it is desirable to adjust the length to the right value if feeder radiation is to be avoided.

With tuned feeders, a fairly simple way to adjust the length is to leave off the connection between the antenna and feeders (but with the feeders in place) and hoist the assembly to its final position. Then carry out the tuning procedure just as described previously, using loose coupling so that the resonance point is quite marked. Low power should be used, especially with series tuning, since without the antenna connected the feeder current will be much greater than normal. Then lower the antenna, connect the feeder, hoist again, and with the coupling just as it was before, again adjust the antenna condensers to resonance. If resonance occurs at the same condenser settings the antenna length is correct. If more capacity must be used, the antenna is too short; if less, the wire is too long. Add or subtract, as the case may be, a few inches to the antenna and try again. The correct length should be found after a few trials. The antenna may be intentionally made a little long

in the first place so that no joints in the wire will be needed when the final length is reached.

An alternative method is to use a regenerative detector as a resonance indicator, coupling it loosely to the antenna, from which the feeders are disconnected for the test. (If the antenna is to be center fed the length should be checked before cutting the wire at the center.) Careful tuning with the detector just oscillating will show resonance as a setting at which the detector is pulled out of oscillation. The frequency at which this occurs may be checked by one of the methods given in Chapter 17; if it is higher than desired the antenna should be lengthened and *vice versa*.

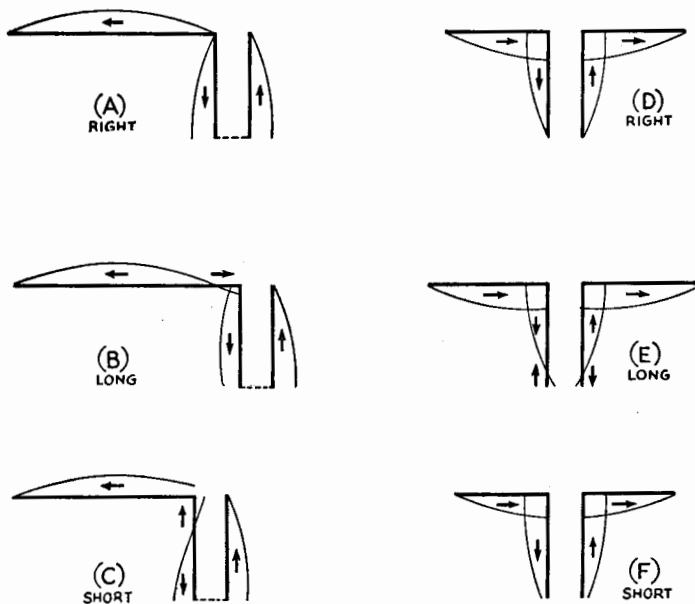

Fig. 2216 — Effect on feeder balance of incorrect antenna length. With center feed, incorrect antenna length does not unbalance the feed system, as it does with end feed.

Long Wire Antennas

Directional Characteristics — Multiband Operation — “V” and Rhombic Antennas

AN ANTENNA will be resonant if an integral number of standing waves of current and voltage can exist along its length. In other words, the antenna will radiate well so long as its length is some integral multiple of a half-wavelength. When the antenna is more than a half-wave long, it is usually called a long-wire antenna, or a harmonic antenna.

Fig. 2301 shows the current and voltage distribution along a wire operating at its fundamental frequency (where its length is

the fourth harmonic, as in *D*. The number of the harmonic is the number of half-waves contained in the antenna at the particular operating frequency.

It is evident that one antenna may be used for harmonically related frequencies, such as the various amateur bands. The long-wire or harmonic antenna is the basis of multi-band operation with one antenna.

As the wire is made longer, in terms of the number of half wavelengths, the antenna characteristics change; this is particularly true of the directional effects. Instead of the “doughnut” pattern of the half-wave antenna, the directional characteristic splits up into “lobes” which make various angles with the wire. In general, as the length of the wire is increased the direction of maximum radiation tends to approach the line of the antenna itself.

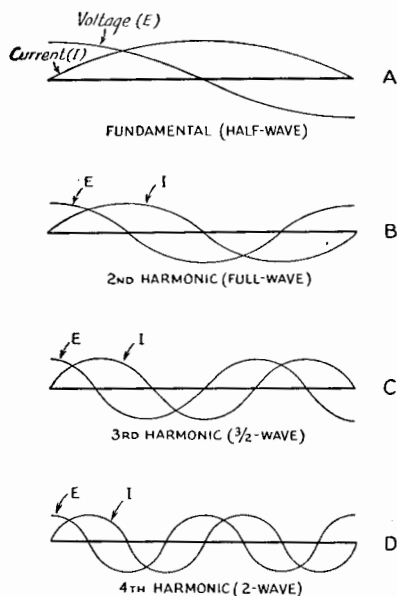

Fig. 2301 — Current and voltage distribution along an antenna operated at various harmonics of its fundamental resonant frequency.

equal to a half wavelength) and at its second, third and fourth harmonics. For example, if the fundamental frequency of the antenna is 7 Mc., the current and voltage distribution will be as shown at *A*. The same antenna excited at 14 Mc. would have current and voltage distribution as shown at *B*. At 21 Mc., the third harmonic of 7 Mc., the current and voltage distribution would be as in *C*; and at 28 Mc.,

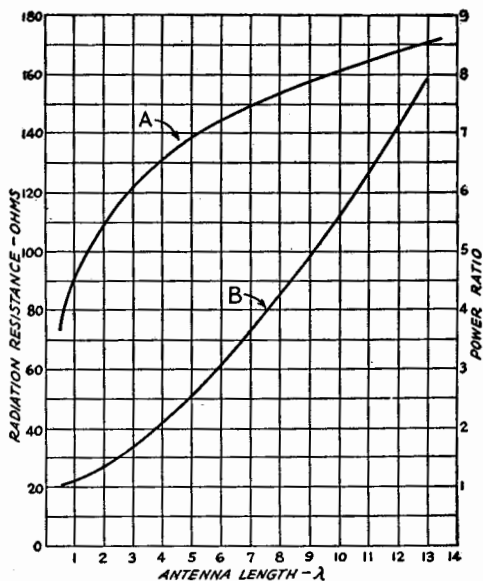

Fig. 2302 — The important curves for harmonically-operated horizontal antennas. Curve *A* shows the variation in radiation resistance with antenna length. Curve *B* shows the power in the lobes of maximum radiation for long-wire antennas as a ratio to the maximum of a half-wave antenna.

The Radio Amateur's Handbook

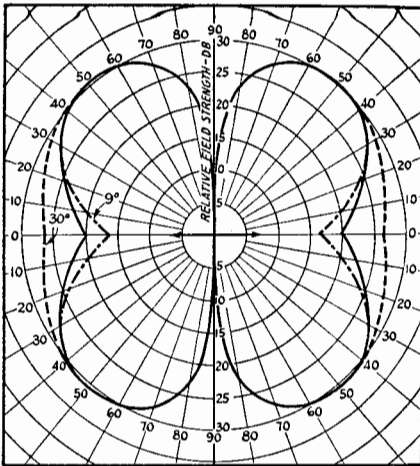

Fig. 2303 — Horizontal patterns of radiation from a full-wave antenna. Solid line, vertical angle 15 degrees; dotted lines, deviation from 15-degree pattern at 9 and 30 degrees.

All three patterns are drawn to the same relative scale; actual amplitudes will depend upon the height of the antenna.

When the same antenna is used for work in several bands, it must be realized that the directional characteristic will depend on the band in use.

The radiation resistance as measured at a current loop becomes larger as the antenna length is increased. Also, a long-wire antenna radiates more power in its most favorable

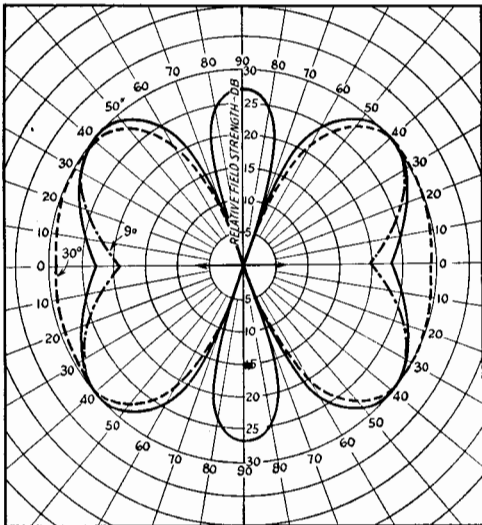

Fig. 2304 — Horizontal patterns of radiation from an antenna three half-wavelengths long. Solid line, vertical angle 15 degrees; dotted lines, deviation from 15-degree pattern at 9 and 30 degrees. The minor lobes coincide for all three angles. See Fig. 2303 for further discussion.

direction than does a half-wave antenna in its most favorable direction. This power gain is secured at the expense of radiation in other directions. Fig. 2302 shows how the radiation resistance and power in the lobe of maximum radiation vary with the antenna length.

Directional characteristics for antennas one wavelength, three half-wavelengths, and two wavelengths long are given in Figs. 2303, 2304, and 2305, for the three vertical angles of radiation considered in Chapter 21. Note that as the wire length increases the radiation along the line of the antenna becomes more pronounced. Still longer antennas can be considered to be practically "end-on" radiators, even at the lower radiation angles.

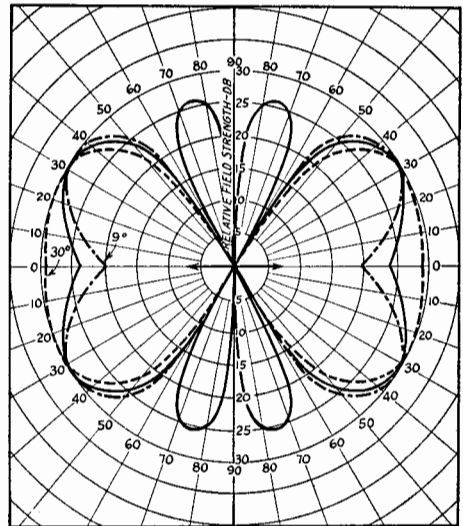

Fig. 2305 — Horizontal patterns of radiation from an antenna two wavelengths long. Solid line, vertical angle 15 degrees; dotted lines, deviation from 15-degree pattern at 9 and 30 degrees. The minor lobes coincide for all three angles. See Fig. 2303 for further discussion.

The length of a long-wire antenna is not an exact multiple of that of a half-wave antenna because the end effects operate only on the end sections of the antenna; in other parts of the wire these effects are absent and the wire length is approximately that of an equivalent portion of the wave in space. The formula for the length of a long-wire antenna therefore is:

$$\text{Length (feet)} = \frac{492 (N-0.05)}{\text{Freq. (Mc.)}} \quad (1)$$

where N is the number of half-waves on the antenna. From this it is apparent that an antenna cut as a half-wave for a given frequency will be slightly off resonance at exactly

Long Wire Antennas

twice that frequency (on the second harmonic) because of the different behavior of end effects when there is more than one standing wave on the antenna. For instance, if the antenna is cut to exact fundamental resonance with a given crystal frequency, on the second harmonic (full-wave) it should be 2.6% longer, and on the fourth harmonic (two-wave), 4%

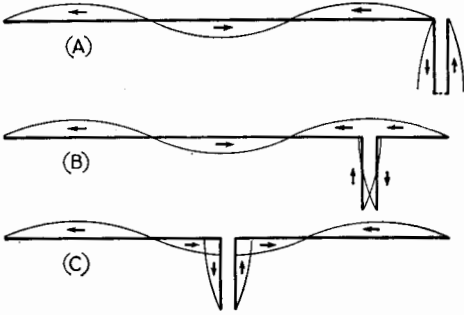

Fig. 2306 — Current distribution and feed points for long-wire antennas. A 3/2-wave antenna is used as an illustration. With two-wire feed, the line may be connected at the end of the antenna or at any current loop (not at a current node). The feeders may be of the resonant type, or a 600-ohm line may be used through a quarter-wave matching section. The "Q" type of matching section also may be used.

longer. The effect is not very important except for a slight unbalance in the feeder system, which may result in some radiation from the feeder (see Chapter 22).

Feeding Long Wires

In a long-wire antenna the currents in adjacent half-wave sections must be out of phase, as shown in Fig. 2306. The feeder system must not upset this phase relationship. This requirement is met by feeding the antenna at either end or at any current loop. A two-wire feeder cannot be inserted at a current node, however, because this invariably brings the currents in two adjacent half-wave sections in phase; if the phase in one section could be reversed then the currents in the feeders would be in phase and the feeder radiation would not be cancelled out.

Either resonant or non-resonant feeders may be used. With the latter, the systems employing a matching section are best. The non-resonant line may be tapped on the matching section as in Fig. 2210, Chapter 22, or a "Q" type section (Fig. 2212, Chapter 22) may be employed. In such case, Fig. 2307 gives the required surge impedance for the matching section. It can also be calculated from Equation (4), Chapter 22, and the radiation resistance data in Fig. 2302.

Methods of coupling the line to the transmitter are the same as described in Chapter 22 for the particular type of line used.

• MULTI-BAND OPERATION

As suggested in the preceding section, the same antenna may be used for several bands by operating it on harmonics (as a long wire) where necessary. When this is done, it is necessary to use resonant feeders, since the impedance matching for non-resonant feeder operation can be accomplished only at one frequency unless means are provided for changing the length of a matching section and shifting the point at which the feeder is attached to it. Obviously a matching section which is a quarter-wavelength long on one frequency will be a half-wavelength long on twice that frequency, and so on, and it is equally obvious that chang-

Antenna Length (ft.)	Feeder Length (ft.)	Band	Type of Tuning
With end feed: 243	120	1.75-Mc. 'phone	series
		4-Mc. 'phone	parallel
		14 Mc. 28 Mc.	parallel parallel
136	67	3.5-Mc. c.w.	series
		7 Mc.	parallel
		14 Mc. 28 Mc.	parallel parallel
134	67	3.5-Mc. c.w.	series
		7 Mc.	parallel
67	33	7 Mc.	series
		14 Mc.	parallel
		28 Mc.	parallel
With center feed: 272	135	1.75 Mc.	parallel
		3.5 Mc.	parallel
		7 Mc.	parallel
		14 Mc.	parallel
		28 Mc.	parallel
137	67	3.5 Mc.	parallel
		7 Mc.	parallel
		14 Mc. 28 Mc.	parallel parallel
67.5	34	7 Mc.	parallel
		14 Mc.	parallel
		28 Mc.	parallel

The antenna lengths given represent compromises for harmonic operation because of different end effects on different bands. The 136-foot end-fed antenna is slightly long for 3.5 Mc., but will work well in the region (3500-3600 kc.) which quadruples into the 14-Mc. band. Bands not shown are not recommended for the particular antenna. The center-fed systems are less critical as to length; the 272-foot antenna may, for instance, be used for both c.w. and 'phone on either 1.75 or 4 Mc. without loss of efficiency.

On harmonics, the end-fed and center-fed antennas will not have the same directional characteristics, as explained in the text.

The Radio Amateur's Handbook

ing the length of the wires, even by switching, is inconvenient.

Also, the current loops shift to a new position on the antenna when it is operated on harmonics, further complicating the feed situation. It is for this reason that half-wave antennas center-fed by rubber-insulated lines are practically useless for harmonic operation; on all even harmonics there is a voltage maximum at the feed point and the impedance mismatch is so bad that there is a large standing-wave ratio and consequently high losses in the rubber dielectric.

Any of the antenna arrangements shown in Fig. 2214, Chapter 22, may be used for multi-band operation by making the antenna a half wave long at the lowest frequency to be used. The feeders should be a quarter wave, or some multiple of a quarter wave, long at the same frequency. Typical examples, with the type of tuning to be used, are given in Table I. The figures given represent a compromise to give satisfactory operation on all the bands considered, taking into account the change in required length as the order of the harmonic goes up.

A center-fed half-wave antenna will not operate as a long wire on harmonics because of the phase reversal at the feeders previously mentioned. On the second harmonic, the two antenna sections are each a half wave long, and since the currents are in phase the directional characteristic is different from that of a full-wave antenna even though the overall length is the same. On the fourth harmonic, each section is a full wave long and again because of the direction of current flow the system will not operate as a two-wave antenna. It should not be assumed that these systems are not effective radiators — it is simply that the directional characteristic will not be that of a long-wire having the same overall length. Rather it will resemble the characteristic of one side of

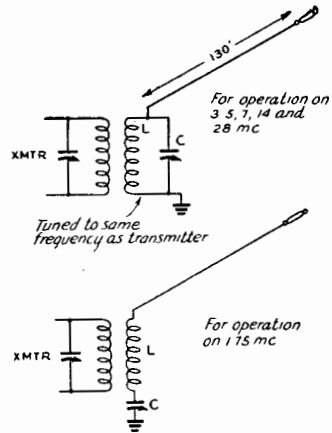

Fig. 2308 — A simple antenna system for five amateur bands. The antenna is voltage fed on 3.5, 7, 14 and 28 Mc., working on the fundamental, second, fourth and eighth harmonics, respectively. For 1.75 Mc. the system is a quarter-wave grounded antenna, in which case series tuning must be used. The antenna wire should be kept well in the clear and should be as high as possible. If the length of the antenna is approximately 260 feet, voltage feed can be used on all five bands.

the antenna, although this is not exact. The center-fed antenna, when operated on harmonics, will radiate equally as well as the end-fed.

Antennas with a few other types of feed systems may be operated on harmonics for the higher-frequency bands, although their performance is somewhat impaired. The single-wire fed antenna (Chapter 22) may be used in this way; the feeder and antenna will not be matched exactly on harmonics with the result that standing waves will appear on the feeder, but the system as a whole will radiate. The same is true of the delta-matched antenna. The "Q" antenna also can be operated on harmonics, but the line cannot operate non-

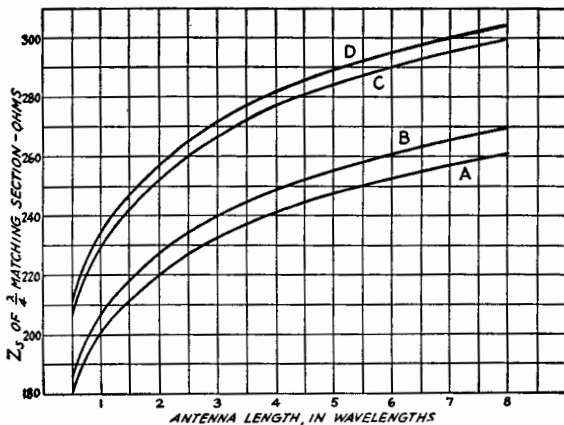

Fig. 2307 — Required surge impedance of quarter-wave matching sections for radiators of various lengths. Curve A is for a transmission line impedance of 440 ohms, Curve B for 470 ohms, Curve C for 580 ohms and Curve D for 600 ohms.

Long Wire Antennas

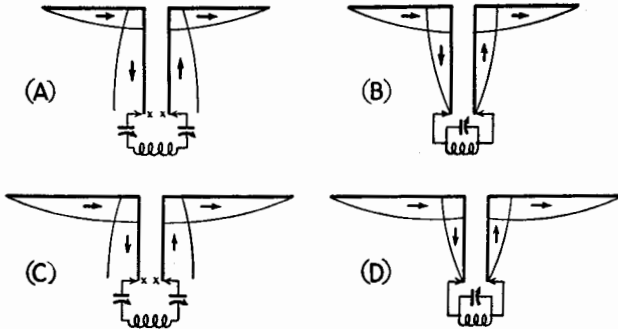

Fig. 2309 — Current distribution on antennas too short for the fundamental frequency. These systems may be used when space for a full half-wave antenna is not available. The current distribution on the second harmonic also is shown to the right of each figure. In A and C, the total length around the system is a half-wavelength at the fundamental frequency.

resonant except at the fundamental frequency of the antenna. For harmonic operation the line must be tuned and, therefore, the feeder length is important. The tuning system will depend upon the number of quarter waves on the line, including the "Q" bars. The concentric-line fed antenna may be used on harmonics if the concentric line is air-insulated. Its operation on harmonics is similar to that of the "Q." This antenna is not recommended for multiband operation with a rubber-insulated line, however.

A simple antenna system, without feeders, for operation in five bands is shown in Fig. 2308. On all bands from 3.5 Mc. upward it operates as an end-fed antenna — half-wave on 3.5 Mc., long wire on the other bands. On 1.75 Mc. it is only a quarter-wave in length and must be worked against ground, which in effect replaces the missing half of the antenna. Since on this band it is fed at a high-current point, series tuning must be used.

● ANTENNAS FOR RESTRICTED SPACE

If the space available for the antenna is not large enough to accommodate the length necessary for a half-wave at the lowest frequency to be used, quite satisfactory operation can be secured by using a shorter antenna and making up the missing length in the feeder system. The antenna itself may be as short as a quarter wavelength and still radiate fairly well, although of course it will not be as effective as one a half-wave long. Nevertheless such a system is useful where operation on the desired band otherwise would be impossible.

Resonant feeders are a practical necessity with such an antenna system, and a center-fed antenna will give best all-around performance. With end feed the feeder currents become badly unbalanced and, since lengths midway between those requiring series or parallel tuning ordinarily must be used to bring the entire system to resonance, coupling to the transmitter often becomes difficult.

With center feed, practically any convenient length of antenna can be used if the feeder

Antenna Length (ft.)	Feeder Length (ft.)	Band	Type of Tuning
137	68	1.75 Mc.	series
		3.5 Mc.	parallel
		7 Mc.	parallel
		14 Mc.	parallel
		28 Mc.	parallel
100	38	3.5 Mc.	parallel
		7 Mc.	series
		14 Mc.	series
		28 Mc.	series or parallel
67.5	34	3.5 Mc.	series
		7 Mc.	parallel
		14 Mc.	parallel
		28 Mc.	parallel
50	43	7 Mc.	parallel
		14 Mc.	parallel
		28 Mc.	parallel
33	51	7 Mc.	parallel
		14 Mc.	parallel
		28 Mc.	parallel
33	31	7 Mc.	parallel
		14 Mc.	series
		28 Mc.	parallel

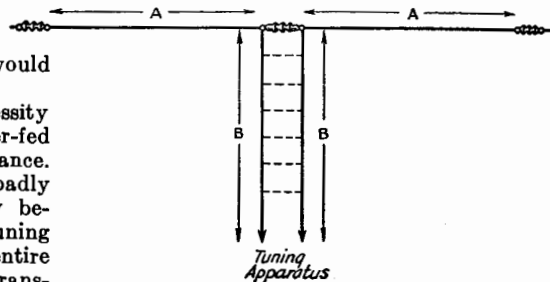

Fig. 2310 — Practical arrangement of a shortened antenna. The total length $A + B + B + A$, should be a half-wavelength for the lowest-frequency band, usually 3.5 Mc. See Table II for lengths and tuning data.

The Radio Amateur's Handbook

length is adjusted to accommodate at least one half-wave around the whole system. Typical cases are shown in Fig. 2309, one for an antenna having a length of one-quarter wave (A) and the other for an antenna somewhat longer (C) but still not a half-wave long. Current distribution is shown for both fundamental and second harmonic. From the points marked X resonant feeders any appropriate number of quarter waves in length may be extended to the operating room. The sum of the distances on each wire from X to the antenna end must equal a half-wave. It is sufficiently accurate to use Equation (1) Chapter 21, in calculating this length. Note that X-X is a high-current point on these shortened antennas, corresponding to the center of a half-wave antenna. It is also apparent that the antenna at A is a half-wave antenna on the next higher-frequency band (B).

The practical antenna can be made as in Fig. 2310. Table II gives a few recommended lengths. Remembering the preceding discussion, however, the antenna can be made any convenient length provided the feeder is considered to "begin" at X-X, and the line length adjusted accordingly.

Bent Antennas

Since the field strength at a distance is proportional to the current in the antenna, the high-current part of a half-wave antenna (the

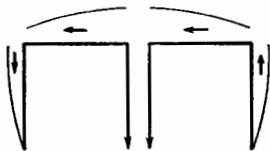

Fig. 2311 — Folded arrangement for shortened antennas. The total length is a half-wave, not including the feeders. The horizontal part is made as long as convenient and the ends dropped down to make up the required length. The ends may be bent back on themselves in feeder fashion to cancel radiation partially. The horizontal section should be at least a quarter-wave long.

center quarter-wave, approximately) does most of the radiating. Advantage can be taken of this fact when the space available does not permit erecting an antenna a half-wave long. To accomplish it, the ends may be bent, either horizontally or vertically, so that the total length equals a half wave, even though the straightaway horizontal length may be as short as a quarter wave. The operation is illustrated in Fig. 2311. Such an antenna will be a somewhat better radiator than the arrangement of Fig. 2309-A on the lowest frequency, but is not as desirable for multi-band operation because the ends play an increasing part as the frequency is raised. The performance of the

system in such a case is difficult to predict, especially if the ends are vertical (the most convenient arrangement) because of the combination of horizontal and vertical polarization as well as dissimilar directional characteristics.

LONG-WIRE DIRECTIVE ANTENNAS

Inspection of Fig. 2302 shows that as a wire is made long there is a considerable increase in the effective power radiated in the optimum direction as compared to a half-wave antenna in its most favorable direction. This comes about because of the higher directivity of the long wire, and is just as advantageous in increasing the signal strength at a distant point as an actual increase in transmitter power would be, provided the receiving station is located in line with the maximum lobe of radiation from the antenna.

A single long wire makes a fair directive antenna, provided its length is 4 wavelengths or more, and shows increasing power gain and directivity as the length is increased. It is, furthermore, possible to combine two or more long wires into even more effective directive systems. The "V" and rhombic antennas are outstanding examples of this procedure.

The "V" Antenna

It has been emphasized in connection with long-wire antennas that as the antenna length is increased the lobe of maximum radiation makes a more acute angle with the wire. Two such wires may be combined in the form of a horizontal "V" so that the main lobes from each wire will reinforce along a line bisecting the angle between the wires. This increases both gain and directivity, since the lobes in directions other than along the bisector cancel to a greater or lesser extent. The horizontal "V" antenna therefore transmits best in either direction (is bi-directional) along the line bisecting the "V" made by the two wires. The power gain depends upon the length of the wires. Provided the necessary space is available, the "V" is a simple antenna to build and operate, and can be used readily on harmonics so that it is suitable for multi-band work. The "V" antenna is shown in Fig. 2312.

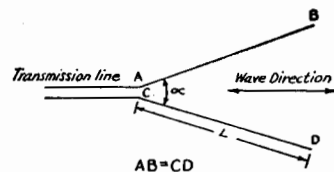

Fig. 2312 — The "V" antenna. The "V" is made by combining two long wires in such a way that each reinforces the other's radiation. The important quantities are the length of each leg and the angle between legs.

Long Wire Antennas

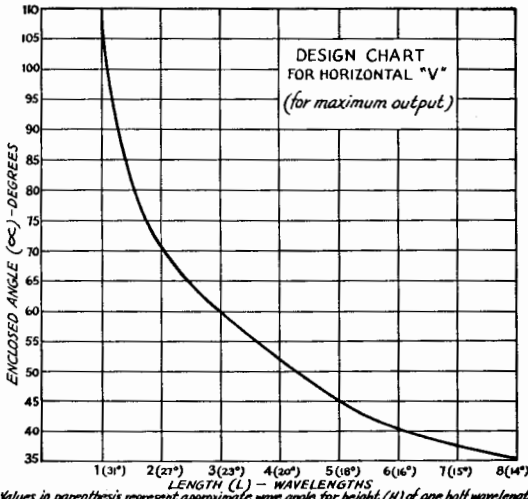

Fig. 2313 — Design chart for horizontal "V" antennas. Enclosed angle between wires versus length of sides.

Fig. 2313 shows the dimensions that should be followed for an optimum design to obtain maximum power gain for different-sized "V" antennas. The longer-type systems give good performance on multi-band operation. Angle α is approximately equal to twice the angle of maximum radiation for a single wire equal in length to one side of the "V."

The "V" can be made unidirectional through eliminating the rear pattern by the use of another "V" one-quarter wave to the rear to act as a reflector. This is quite cumbersome for amateur practice and restricts correct operation to a single frequency band. The "V" usually is operated as a bi-directional antenna.

The wave angle referred to in Fig. 2313 is the vertical angle of maximum radiation. Tilting the whole horizontal plane of the "V" will tend to increase the low-angle radiation off the low end and decrease it off the high end.

The gain increases with the length of the wires, but is not exactly twice the gain for a single long wire as given in Fig. 2302. In the longer lengths, the gain will be somewhat increased because of mutual coupling between the wires. A "V" eight wavelengths on a leg, for instance, will have a gain of about 12 db over a half-wave antenna, whereas twice the gain of a single 8-wavelength wire would be approximately 9 db.

The two wires of the "V" must be fed out of phase for correct operation. A resonant line may simply be attached to the ends as shown in

Fig. 2312. Alternatively, a quarter-wave matching section may be employed and the antenna fed through a non-resonant line. If the antenna wires are made multiples of a half-wave in length (use Equation (1) for computing the length) the matching section will be closed at the free end.

The Rhombic Antenna

The horizontal rhombic or "diamond" antenna is shown in Fig. 2314. Like the "V," it requires a good deal of space for erection, but it is capable of giving excellent gain and directivity. It can also be used for multi-band operation. In the terminated form shown in Fig. 2314 it operates, like a non-resonant transmission line, without standing waves, and is uni-directional. It may also be used without the terminating resistor, in which case there are standing waves on the wires and the antenna is bi-directional.

The important quantities influencing the design of the rhombic antenna are shown in Fig. 2314. While several design methods may be used, the one most applicable to the conditions existing in amateur work is the so-called "compromise" method. The charts of Figs. 2315 and 2316 give design information when two of the quantities are assumed. The examples given illustrate the practical use of the charts.

For multi-band work, it is satisfactory to design the rhombic antenna on the basis of 14-Mc. operation, which will permit work on the 7- and 28-Mc. bands as well.

Fig. 2315 is based on an original given premise of length and height from which is determined the proper angle of tilt and corresponding wave angle for maximum output. This chart is based upon an effective height of $\frac{1}{2}$ wavelength, which represents a practical value

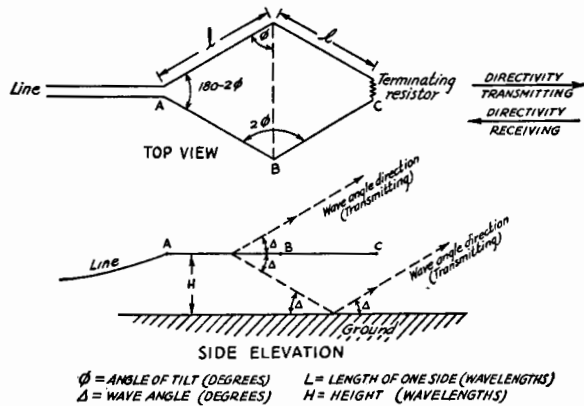

Fig. 2314 — The horizontal rhombic — or diamond antenna, terminated.

The Radio Amateur's Handbook

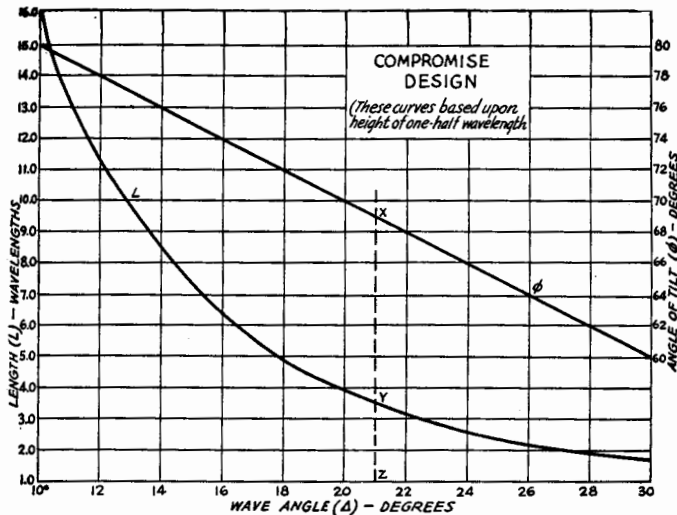

Fig. 2315 — Design chart for rhombic antennas with fixed height (one-half wavelength). The following example illustrates the use of the Chart:

Given: Height = $\frac{1}{2}$ wavelength.

Available length of one leg = 3.5 wavelengths.

To Find:

Angle of Tilt (ϕ).

Wave Angle (Δ).

Method:

Place straight edge on curve "L" at 3.5 wavelengths (point y) and draw line

XYZ. Read angle ϕ from intersection at point X (right hand ordinate)

and angle Δ at point Z (intersection of abscissa).

Result:

H = $\frac{1}{2}$ wavelength	} given.
L = 3.5 wavelengths	
Tilt angle $\phi =$	} from curves.
69 degrees	
Wave angle $\Delta =$	
21 degrees	

Fig. 2316 — Compromise method design chart for various leg lengths and wave angles. The following examples illustrate the use of the Chart:

(1) Given: Length (L) = 2 wavelengths.

Desired wave angle (Δ) = 20° .

To Find: H, ϕ .

Method:

Draw vertical line through point "a" (L = 2 wavelengths) and point "b" on abscissa ($\Delta = 20^\circ$.)

Read angle of tilt (ϕ) for point "a" and height (H) from intersection of line ah at point "c" on curve H.

Result:

$\phi = 60.5^\circ$.

H = 0.73 wavelength.

(2) Given:

Length (L) = 3 wavelengths.

Angle of tilt (ϕ) = 78° .

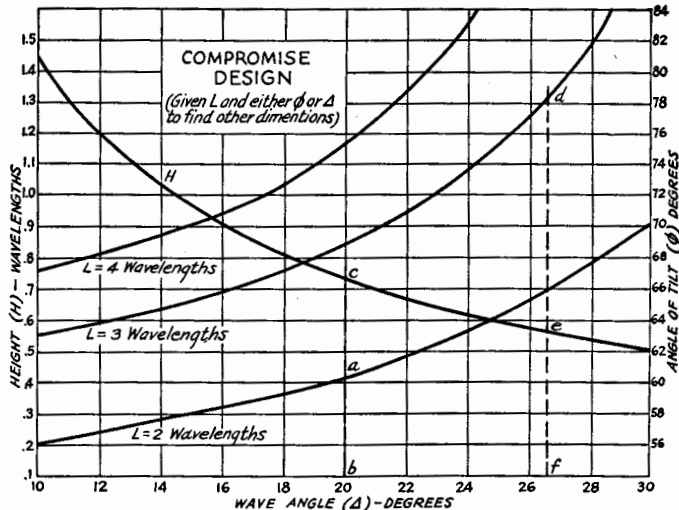

To Find: H, Δ .

Method:

Draw vertical line from point "d" on curve

L = 3 wavelengths at $\phi = 78^\circ$. Read intersection

of this line on curve H (point "e") and

intersection at point "f" on the abscissa for

Δ .

Result:

H = 0.56 wavelength.

$\Delta = 26.6^\circ$.

Long Wire Antennas

for most amateurs. For any different height other than the one shown the curve may be plotted from the expression:

$$\frac{H}{\lambda} = \frac{\lambda}{2\pi \sin \Delta} \frac{l \sin \Delta}{\tan(\pi l \sin^2 \Delta)}$$

The solution of this equation for l in terms of wavelength (λ) may be obtained by the trial and error method.

Fig. 2316 is based upon a premise of a given length and wave angle to determine the remaining optimum dimensions for best operation. Curves for values of length of 2, 3 and 4 wavelengths are shown, and additional curves for any length may be similarly plotted from the relationship:

$$\sin \phi = \frac{l - 0.371 \lambda}{l \cos \Delta}$$

With all other dimensions correct, an increase in length causes an increase in power gain and a slight reduction in wave angle. An increase in height also causes a reduction in wave angle and an increase in power gain but not to the same extent as a proportionate increase in length.

A value of 800 ohms is correct for the terminating resistor for any properly constructed rhombic, and the system behaves as a pure resistive load under this condition. This termi-

nating resistor must be capable of safely dissipating one-half the power output (to eliminate the rear pattern) and should be absolutely non-inductive. Such a resistor may be made up from a carbon or graphite rod or from a long 800-ohm transmission line using resistance wire. If the carbon rod or a similar form of lumped resistance is used the device should be suitably protected from weather effects, i.e., covered with good asphaltic compound and sealed in a small light-weight box or fibre tube. Suitable resistors also are available commercially.

For feeding the antenna, the antenna impedance will be matched by an 800-ohm line, which may be constructed from No. 16 A.W.G. wire spaced 20 inches or from No. 18 A.W.G. wire spaced 16 inches. The 800-ohm line is somewhat ungainly to install, however, and may be replaced by an ordinary 600-ohm line with only a negligible mismatch.

Alternatively, a matching section may be installed between the antenna terminals and a low-impedance line. However, when such an arrangement is used it will be necessary to change the network constants for each different band of operation.

The same design details apply to the unterminated rhombic as to the terminated type. Resonant feeders are preferable for the unterminated rhombic. A non-resonant line may be used by incorporating a matching section at the antenna, but is not readily adaptable to multi-band work.

Rhombic antennas will give a power gain of 10 db or more when constructed according to the charts given. In general, the larger the antenna the greater the power gain.

Multi-Element Directive Systems

Broadside and End-Fire Arrays—Parasitic Arrays—Design and Adjustment

FOR long-distance transmission it is often advantageous to arrange the antenna so that the radiation is concentrated in a desired direction. With a simple antenna, the same increase in field strength would require much more power, so that it is customary to measure the effectiveness of a directive antenna in terms of the power increase that would be needed to give the same field strength, using a half-wave antenna as the standard of comparison. The same polarization is assumed. The power gain so obtained may range from slightly over 1 for simple systems to as much as 30 or 40 for the most elaborate ones.

The increased signal strength in the desired direction is obtained at the expense of radiation in other directions. At the higher frequencies, energy may be taken from the higher vertical angles and used to reinforce the existing low-angle radiation without affecting greatly the horizontal directivity. In general, however, an increase in output in one horizontal direction is accompanied by a decrease in some other horizontal direction, so that the user of a directive antenna must be prepared to accept an area of restricted effectiveness. This is particularly true as the antenna gain is made higher.

The "V" and rhombic antennas described in the preceding chapter will, when made large, give greater gain and directivity than the multi-element types described in this chapter, using a reasonable number of half-wave elements. Furthermore, their operation is not restricted to one band, as is the case with most multi-element types. However, when space is restricted, the multi-element antennas will give more "gain per ground area" than small "V" and rhombic antennas.

A multi-element antenna consists of a number of half-wave antennas (each called an "element") so arranged in space with respect to each other, and with the r.f. currents in the elements so phased, that the individual radiations from them add in certain directions and oppose in others. There are several meth-

ods of arranging the elements. If they are strung end to end so that all lie on the same straight line, the elements are said to be **collinear**. If they are parallel and all lying in the same plane, the elements are said to be **broadside** when the phase of the current is the same in all, and **end-fire** when the currents are not in phase. A combination of elements is called an **array**. Elements which receive power from the transmitter through the transmission line are called **driven elements**, while those which are excited solely by coupling because of the proximity of a driven element are said to be **parasitic elements**. Both driven and parasitic elements may be combined in multi-element arrays.

The power gain of a directive system depends upon the sharpness of the solid directive pattern, and increases as the number of elements is made larger. The proportionality between gain and number of elements is not simple, however, but depends upon the effect of the spacing and phasing upon the radiation resistance of the elements as well as upon their number.

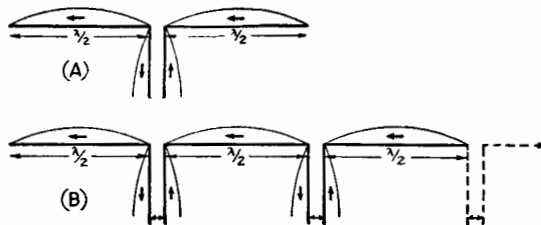

Fig. 2401 — Collinear half-wave antennas in phase. The system at A is generally known as "two-half-waves in phase." B is an extension of the system; in theory it may be carried on indefinitely, but practical considerations usually limit the number of elements to four. Gain figures are tabulated in Table I.

Resonant feeders may be connected to the ends of any of the quarter-wave phasing sections indicated (the shorting bar of course must be removed from the one used). Alternatively a two-wire line may be matched to one of the stubs, using it as a matching transformer (Chapter 22). Any antenna element also may be center-fed through any of the ordinary methods which permit matching, in the case of a non-resonant line, or through a resonant line. Twisted pair and concentric feeders are not recommended for this purpose because the antenna impedance is not the same as when a half-wave antenna is used singly. Generally speaking, it is preferable to feed a multi-element antenna near the center of the system in order to make the power distribution to the elements as uniform as possible.

Multi-Element Directive Systems

A directive antenna is equally as effective for receiving as for transmitting. Such an antenna should always be used for both purposes if its full benefits are to be realized.

Collinear Arrays

Simple forms of collinear arrays, with the current distribution, are shown in Fig. 2401. The two-element array at A is popularly known as "two half-waves in phase." It will be recognized as simply a center-fed antenna operated at its second harmonic. The way in which the number of elements may be extended for increased directivity and gain is shown in Fig. 2401-B. Note that quarter-wave transmission lines are used between each element; these give the reversal in phase necessary to make the currents in individual antenna elements all flow in the same direction at the same instant. Another way of looking at it is to consider that the whole system is a long wire with alternate half-wave sections folded so that they do not radiate. Any phase-reversing section may be used as a quarter-wave matching section for attaching a non-resonant feeder. A resonant transmission line may be substituted for any of the quarter-wave sections, of course. Also, the antenna may be end-fed by any of the systems previously described, or any element may be center-fed. It is best to feed as near the center of the array as possible so that the energy will be distributed as uniformly as possible among the elements.

The gain and directivity depend upon the number of elements and their spacing, center-to-center. This is shown by Table I. Although $\frac{3}{4}$ -wave spacing gives greater gain, it is difficult to construct a suitable phase-reversing system when the ends of the antenna elements are widely separated. For this reason the half-wave spacing is generally used.

Collinear arrays may be mounted either horizontally or vertically. Horizontal mounting gives horizontal directivity, with vertical directivity the same as for a single element at the same height. Vertical mounting gives the same horizontal pattern as a single element, but concentrates the radiation at low angles. It

Spacing Between Centers of Adjacent Half Waves	Number of Half Waves in Array vs. Gain in db				
	2	3	3	5	6
$\frac{1}{2}$ Wave	1.8	3.3	4.5	5.3	6.2
$\frac{3}{4}$ Wave	3.2	4.8	6.0	7.0	7.8

180° Out of Phase (End Fire)		In Phase (Broadside)	
Separation in Fractions of a Wavelength	Gain in db	Separation in Fractions of a Wavelength	Gain in db
$\frac{1}{8}$	4.3	$\frac{5}{8}$	4.8
$\frac{1}{20}$	4.1	$\frac{3}{4}$	4.6
$\frac{1}{4}$	3.8	$\frac{1}{2}$	4.0
$\frac{3}{8}$	3.0	$\frac{3}{8}$	2.4
$\frac{1}{2}$	2.2	$\frac{1}{4}$	1.0
$\frac{5}{8}$	1.7	$\frac{1}{8}$	0.3

is seldom possible to use more than two elements vertically, however, even at 14 Mc., because of the height required.

Broadside Arrays

Parallel antenna elements with currents in phase may be combined as shown in Fig. 2402 to form a *broadside* array, so named because the direction of maximum radiation is broadside to the plane containing the antennas. Again the gain and directivity depend upon the number of elements and the spacing, the gain for different spacings being shown in the right-hand section of Table II. Half-wave spacing is generally used, since it simplifies the feeding problem when the array has more than two elements.

Broadside arrays may be suspended either horizontally or vertically. In the former case the horizontal pattern is quite sharp while the vertical pattern is that of one element alone. If the array is suspended horizontally the horizon-

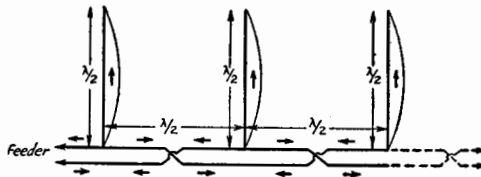

Fig. 2402 — The broadside array using half-wave elements. Arrows indicate direction of current flow. The transposition in feeders is necessary to bring the antenna currents in phase. Any reasonable number of elements may be used. The array is bi-directional perpendicular to the plane of the antenna; i.e., perpendicularly through this page.

Resonant feeders or quarter-wave matching sections may be bridged across the line at any antenna junction. If the transmission line is connected to the phasing line at a point midway between two antennas, the phasing line in that section should not be transposed. Feed near the center of the system is preferable in order to distribute the power as evenly as possible among the antennas.

See Table II for gain data.

The Radio Amateur's Handbook

tal pattern is that of one element while the vertical pattern is sharp, giving low-angle radiation. The height required limits the number of elements which can be suspended horizontally, so that more than two seldom are used.

Broadside arrays may be fed either by resonant transmission lines or by the use of quarter-wave matching sections and non-resonant lines. In Fig. 2402, note the "crossing over" of the feeder, necessary to bring the elements in proper phase relationship.

Combined Broadside and Collinear Arrays

Broadside and collinear arrays may be combined to give both horizontal and vertical di-

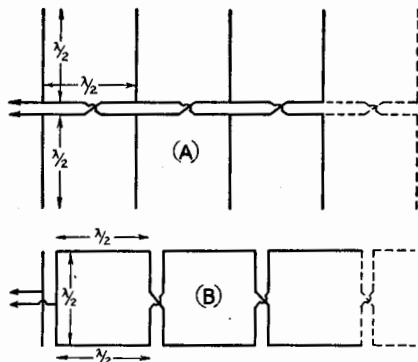

Fig. 2403—Combination broadside and collinear arrays. *A*, with vertical elements; *B*, with horizontal elements. Both arrays give low-angle radiation. Two or more sections may be used. See Fig. 2402 for remarks on feeding and directivity. The transmission-line connection in *B* illustrates the use of a non-transposed phasing line when the connection is midway between antenna elements.

The gain in db will be equal, approximately, to the sum of the gain for one set of broadside elements (Table III) plus the gain of one set of collinear elements (Table I). For example, in *A* each broadside set has four elements (gain 7 db) and each collinear set two elements (gain 1.8 db) giving a total gain of 8.8 db. In *B* each broadside set has two elements (gain 4 db) and each collinear set three elements (gain 3.3 db) making the total gain 7.3 db. The result is not strictly accurate because of mutual coupling between elements, but is good enough for practical purposes.

rectivity, as well as additional gain. The general plan of constructing such antennas is shown in Fig. 2403. The lower angle of radiation resulting from "stacking" elements in the vertical plane is desirable at the higher frequencies. In general, doubling the number of elements in an array by stacking will raise the gain 2 to 4 db, depending upon whether vertical or horizontal elements are used.

The arrays in Fig. 2403 are shown fed from one end, but this is not especially desirable in the case of large arrays. Better distribution of energy between elements, and hence a better all-around performance, will result when the

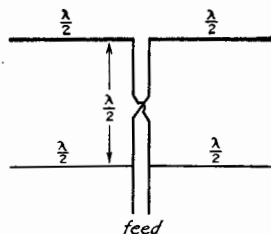

Fig. 2404—This four-element combination broadside-collinear array is popularly known as the "lazy H" antenna. A closed quarter-wave stub may be used at the feed point to match into a 600-ohm line, or resonant feeders may be attached at the point shown. The gain over a half-wave antenna is 5 to 6 db.

feeders are attached as nearly as possible to the center of the array. Thus in the 8-element array at *A* the feeders could be introduced at the middle of the transmission line between the second and third set of elements, in which case the connecting line would not be transposed. Or the antenna could be constructed with the transpositions as shown and the feeder connected between the adjacent ends of either the second or third pair of collinear elements.

A four element array of the general type shown at *B* is frequently used, and is currently known as the "Lazy H" antenna. It is shown, with the feed point indicated, in Fig. 2404.

End-Fire Arrays

Fig. 2405 shows a pair of parallel half-wave elements with currents out of phase. This is known as an end-fire array because it radiates best along the line of the antennas, as shown.

The end-fire array may be used vertically or horizontally, and is well adapted to amateur work because it gives maximum gain with relatively close element spacing. Table II shows how the gain varies with spacing. End-fire elements may be combined with additional collinear and broadside elements further to increase the gain and directivity.

Either resonant or non-resonant lines may be used with this type of array, the latter being preferably matched to the antenna through a quarter-wave resonant line.

No. of Elements	Gain
2	4 db
3	5.5 db
4	7 db
5	8 db
6	9 db

Multi-Element Directive Systems

Checking Phasing

Figs. 2403 and 2405 illustrate a point in connection with feeding a phased antenna system which sometimes is confusing. Taking Fig. 2405 as an example, when the transmission line is connected as at *A* there is no crossover in the line connecting the two antennas, but when the transmission line is connected to the center of the connecting line the crossover becomes necessary (*B*). This is because in *B* the two halves of the connecting line are

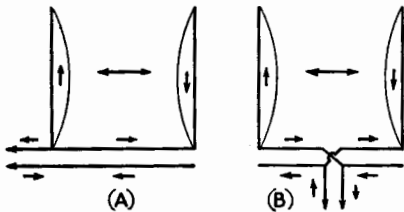

Fig. 2405 — End-fire arrays. They are shown with half-wave spacing to illustrate feeder connections. In practice, closer spacings are desirable, as shown by Table II. Direction of maximum radiation is shown by the large arrows. End-fire arrangements are shown in Fig. 2406 at *A*, *B*, and *C*.

simply *branches* of the same line. In other words, even though the connecting line in *B* is a half-wave in length, it is not actually a half-wave line but *two quarter-wave lines in parallel*. The same thing is true of the untransposed line of Fig. 2403-B. Note that under these conditions the antenna elements are in phase when the line is not transposed, and out of phase when the transposition is made. The opposite is the case when the half-wave line simply joins two antenna elements, and does not have the feed line connected to its center.

Adjustment of Driven Arrays

With arrays of the types just described, using half-wave spacing between elements, it will usually suffice to make the length of each element that given by the equation for a half-wave antenna in Chapter 21, while the half-wave phasing lines between parallel elements can be calculated from the formula

$$\text{Length of half-wave line (feet)} = \frac{492 \times 0.975}{\text{Freq. (Mc.)}} = \frac{480}{\text{Freq. (Mc.)}}$$

The spacing between elements can be made equal to the length of the phasing line. No special adjustments are needed provided the formulas are followed carefully.

With collinear arrays of the type shown in Fig. 2401-B, the same formula may be used for the element length, while the quarter-wave

phasing section can be calculated from Equation (3), Chapter 22. If the array is fed at its center it will not be necessary to make any particular adjustments, although if desired the whole system may be resonated by connecting an r.f. ammeter in the shorting link on each phasing section and moving the link back and forth to find the maximum current position. This refinement is hardly necessary in practice so long as all elements are the same length and the system is symmetrical.

Practical Phased Systems

Several simple directive antenna systems based on the principles described are in rather wide use among amateurs. They are shown in Fig. 2406. Tuned feeders are assumed in all cases; however, a matching section readily can be substituted if a non-resonant transmission line is preferred. Dimensions given are in terms of wavelength; actual lengths readily can be calculated from Equation (1) Chapter 21, for the antenna and Equation (3), Chapter 22, for the resonant transmission line or matching section. Remember that, in cases where the transmission line proper connects to the midpoint of a phasing line, only *half* the length of the latter is added to the line to find the quarter-wave point.

At *A* and *B* are two-element end-fire arrangements using close spacing. They are electrically equivalent; the only difference is in the method of connecting the feeders. *B* may also be used as a four-element array on the second harmonic, although the spacing is not optimum in that case; however, it is a useful two-band directive antenna. A close-spaced four-element array is shown at *C*. It will give about 2 db more gain than the two-element array. The antenna at *D* is designed to take advantage of the greater gain possible with collinear antennas having greater than half-wave center-to-center spacing, but without introducing feed complications. The elements are made longer than a half wave to bring this about. The gain is 3 db over a single half-wave antenna, and the broadside directivity is quite sharp.

The antennas of *A* and *B* may be mounted either horizontally or vertically; horizontal suspension (with the two elements in a plane parallel to the ground) is recommended, since this tends to give low-angle radiation without an unduly sharp horizontal pattern. Thus these systems are useful for coverage over a wide horizontal angle. The system at *C* also should be mounted horizontally. It will have a sharper horizontal pattern than the two-element arrays.

Parasitic Antennas

All the preceding systems are bi-directional; that is, they will radiate both to the "front"

The Radio Amateur's Handbook

and the "back" of the antenna system. If radiation is wanted in only one direction (for instance, north only, instead of north-south) it is necessary to use different element arrangements. In most of these the additional elements receive power by induction or radiation from the antenna and reradiate it in the proper phase relationship to achieve the desired effect. They are called *parasitic* elements, as contrasted to *driven* elements which receive power directly from the transmitter through the transmission line.

The parasitic element is called a *director* when it reinforces radiation on a line pointing

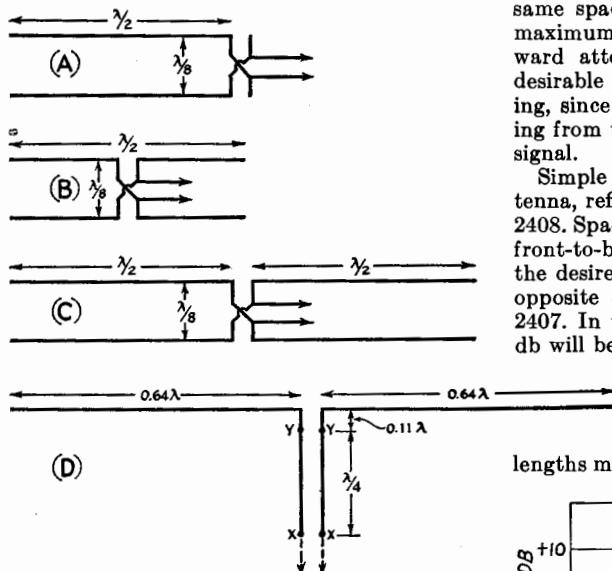

Fig. 2406 — Simple directive systems. *A*, two-element end-fire array; *B*, same with center feed, which permits use of the array on the second harmonic, where it becomes a four-element array with quarter-wave spacing. *C*, four-element end-fire array with $\frac{1}{8}$ -wave spacing. *D*, extended in-phase antennas ("extended double-Zepp"). The gain of *A* and *B* is slightly over 4 db (Table II). On the second harmonic, *B* will give about 5 db gain. With *C*, the gain is approximately 6 db, and with *D*, approximately 3 db.

In the first three, the phasing line contributes about $\frac{1}{8}$ th wavelength to the transmission line; when *B* is used on the second harmonic this contribution is $\frac{1}{8}$ th wavelength. Alternatively, the antenna ends may be bent to meet the transmission line, in which case each feeder is simply connected to one antenna. In *B* and *C* the construction is the same as shown, but each antenna element would be $\frac{1}{8}$ th wavelength shorter. In *D*, points Y-Y indicate a quarter-wave point (high current) and X-X a half-wave point (high voltage). The line may be extended in multiples of quarter-waves, if resonant feeders are to be used.

Resonant feeders may be used with all types shown, and are necessary if *B* is to be used on two bands. Non-resonant feeders may be coupled to the antennas through quarter-wave matching sections for single-band operation.

A, *B*, and *C* may be suspended on wooden spreaders. The plane containing the wires should be parallel to the ground.

to it from the antenna, and is called a *reflector* when the reverse is the case. Whether the parasitic element is a director or reflector depends upon the parasitic element tuning (which usually is adjusted by changing its length) and, particularly when the element is self-resonant, upon the spacing between it and the antenna.

The gain of an antenna-reflector or antenna-director combination varies chiefly with the spacing between elements. The way in which gain varies with spacing is shown in Fig. 2407, for the special case of self-resonant parasitic elements. This chart also shows how the attenuation to the "rear" varies with spacing. The same spacing does not necessarily give both maximum forward gain and maximum backward attenuation. Backward attenuation is desirable when the antenna is used for receiving, since it greatly reduces interference coming from the opposite direction to the desired signal.

Simple and practical combinations of antenna, reflector and director are shown in Fig. 2408. Spacings for maximum gain or maximum front-to-back ratio (ratio of power radiated in the desired direction to power radiated in the opposite direction) may be taken from Fig. 2407. In the chart, the front-to-back ratio in db will be the sum of gain and attenuation at the same spacing.

The antenna length is given by Equation (2), Chapter 21, as usual. The director and reflector

lengths must be determined experimentally for

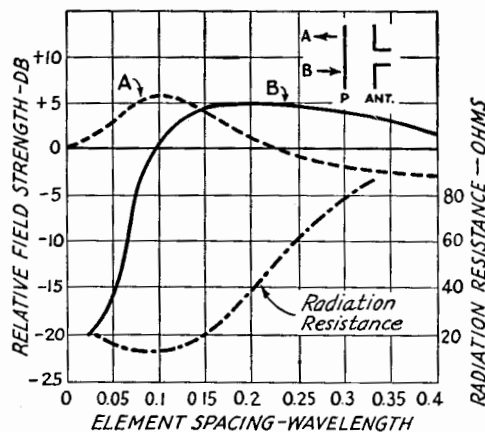

Fig. 2407 — Gain vs. element spacing for an antenna and one parasitic element. Zero db is the field strength from a half-wave antenna alone. Greatest gain is in the direction *A* at spacings less than 0.14 wavelength; in direction *B* at greater spacings. Front-to-back ratio is the difference in db between curves *A* and *B*. Variation in radiation resistance also is shown. These curves are for self-resonant parasitic element. At most spacings the gain as a reflector can be increased by slight lengthening of the parasitic element; as a director, by shortening. This likewise improves the front-to-back ratio.

Multi-Element Directive Systems

maximum performance. The preferable method is to aim the antenna at a receiver a mile or so distant and have an observer check the signal strength (on the "S" meter) while the reflector or director is adjusted a few inches at a time, until the length which gives maximum signal is found. The attenuation may be similarly checked, the length being adjusted for minimum signal. In general, the length of a director will be about 4% less than that of the antenna, for best front-to-back ratio. The reflector will be about 5% longer than the antenna.

Systems of this type are popular for rotary beam antennas, in which the whole antenna is rotated to permit its gain and directivity to be utilized for any compass direction. They may be mounted either horizontally (plane containing the elements parallel to the earth) or vertically.

Arrays using more than one parasitic element, such as those shown at C and D in Fig. 2408, will give more gain and directivity than is indicated for the single reflector and director by the curves of Fig. 2407. The gain with a properly adjusted three-element array (antenna, director and reflector) will be 5 to 7 db over a half-wave antenna, while somewhat higher gain still can be secured by adding a

second director to make a four-element array. The front-to-back ratio is correspondingly improved as the number of elements is increased.

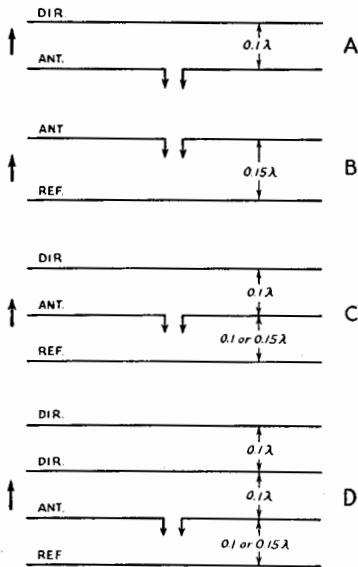

Fig. 2408 — Half-wave antennas with parasitic elements. A, with reflector; B, with director; C, with both director and reflector; D, two directors and one reflector. Gain is approximately as shown by Fig. 2407 in the first two cases and depends upon the spacing and length of the parasitic element. In the three- and four-element arrays a reflector spacing of 0.15 wavelength will give slightly more gain than 0.1-wavelength spacing. Arrows show direction of maximum radiation. The array should be mounted horizontally (these are top views).

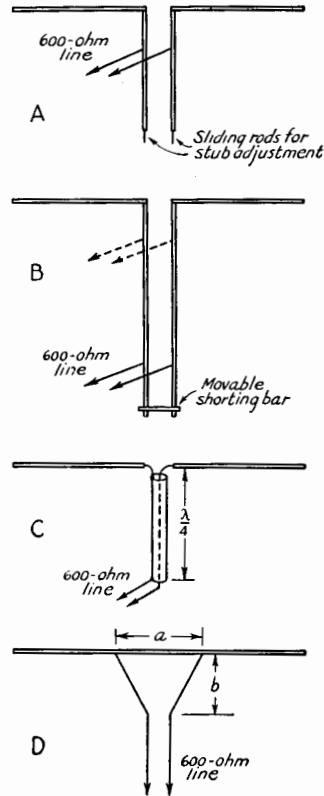

Fig. 2409 — Recommended methods of feeding the driven antenna element in close-spaced parasitic arrays. The parasitic elements are not shown. A, quarter-wave open stub; B, half-wave closed stub; C, concentric-line quarter-wave matching section; D, delta matching transformer.

The elements in close-spaced arrays preferably should be made of tubing of half- to one-inch diameter both to reduce the ohmic resistance and to secure mechanical rigidity. If the elements are free to move with respect to each other the array will show detuning effects in breezy weather.

Feeding Close-Spaced Parasitic Arrays

While any of the usual methods of feed may be applied to the driven element (usually called the "antenna") of a parasitic array, the fact that with close spacing the radiation resistance as measured at the center of the driven element drops to a very low value makes some systems more desirable than others. The preferred methods are shown in Fig. 2409. Reson-

The Radio Amateur's Handbook

ant feeders are not recommended for lengths greater than a half wavelength.

The quarter- or half-wave matching stubs shown at *A* and *B* in Fig. 2409 preferably should be constructed of tubing with rather close spacing, in the manner of the ordinary "Q" section. This lowers the impedance of the matching section and makes the position of the line taps somewhat less difficult to determine accurately. This line adjustment should be made only with the parasitic elements in place, and after the correct element lengths have been determined should be checked to compensate for changes likely to occur because of element tuning. The procedure is the same as that described in Chapter 22.

The concentric-line matching section at *C* will work with fair accuracy into a close-spaced parasitic array of 2, 3 or 4 elements without necessity for adjustment. The line is used as an impedance inverting transformer, and if its characteristic impedance is 70 ohms will give an exact match to a 600-ohm line when the resistance at the termination is about 8.5 ohms. Over a range of 5 to 15 ohms the mismatch, and therefore the standing-wave ratio, will be less than 2 to 1. The length of the quarter-wave section should be calculated from Equation (3), Chapter 22.

The delta matching transformer shown at *D* is an excellent arrangement for parasitic arrays, and probably is easier to install, mechanically, than any of the others. The positions of the taps (dimension *a*) must be determined experimentally, along with the length *b*, by checking the standing-wave ratio on the line as adjustments are made. Dimension *b* should be about 15% longer than *a*.

Combination Arrays

It is possible to combine parasitic elements with driven elements to form arrays composed of collinear driven and parasitic elements and combination broadside-collinear-parasitic elements. Thus two or more collinear elements might be provided with a collinear reflector or director set, one parasitic element to each driven element. Or both directors and reflectors might be used. A broadside-collinear array could be treated in the same fashion.

When combination arrays are built up, a rough approximation of the gain to be expected may be obtained by adding the gains

for each type of combination. Thus the gain of two broadside sets of four collinear arrays with a set of reflectors, one behind each element, at quarter-wave spacing for the parasitic elements, would be estimated as follows: From Table I, the gain of four collinear elements is 4.5 db with half-wave spacing; from Table II, the gain of two broadside elements at half-wave spacing is 4.0 db; from Fig. 2407 the gain of a parasitic reflector at quarter-wave spacing is 4.5 db; the total gain is then the sum, or 13 db for the sixteen elements. Note that using two sets of elements in broadside is equivalent to using two elements, so far as gain is concerned, similarly with sets of reflectors as against one antenna and one reflector. The actual gain of the combination array will depend, in practice, upon the way in which the power is distributed between the various elements, and upon the effect of mutual coupling between elements upon the radiation resistance of the array.

A great many directive antenna combinations can be worked out by combining elements according to these principles.

Broadness of Resonance

Peak performance of a multi-element directive array depends upon proper phasing, which in all but the simplest systems can be exact for one frequency only. However, there is some latitude, and most arrays will work well over a relatively-narrow band such as 14 Mc. If frequencies in all parts of the band are to be used, the antenna system should be designed for the mid-frequency; on the other hand, if only one frequency in the band will be used the greater portion of the time the antenna might be designed for that frequency and some degree of misadjustment tolerated on the occasionally-used spare frequencies.

When reflectors or directors are used the tolerance is usually less than in the case of driven elements, partly because the parasitic-element lengths are fixed and the operation may change appreciably as the frequency passes from one side of resonance to the other, and partly because the close spacing ordinarily used results in a sharp-tuning system. With parasitic elements operation should be confined to a small region about the frequency for which the antenna is adjusted, if peak performance is to be secured.

Antenna Construction

Masts — Rotating Mechanisms — Receiving Antennas — Dummy Antennas

IF THE antenna system is to operate most effectively the conductors must be of low resistance. On the other hand the insulators must have high mechanical strength and low losses. For short antennas an entirely satisfactory conductor is No. 14 gauge hard-drawn enamelled copper wire. For long antennas and directive arrays No. 14 or No. 12 enamelled copper-clad steel wire should be used to prevent any possible stretch. It is best to make feeders of ordinary No. 14 or No. 12 enamelled copper wire. It will be found difficult to make a neat-looking feeder with hard-drawn or copper-clad steel wire unless it is under considerable tension at all times. Every effort should be made to make the wires in one piece so that the only joints are at the output terminals of the transmitter. Where joints cannot be avoided they should be carefully soldered.

If the feeder system is of the tuned type the currents in it will be of the same order as or larger than those in the antenna, and the same care in avoiding joints is necessary. In the open-wire untuned feeder system, however, the currents are relatively low and this consideration is therefore not as important. In these cases small wire can be used if necessary.

In building a resonant two-wire feeder as much care should be taken with the quality of insulation used in the spacers as is taken with the antenna insulators proper. For this reason one of the many good ceramic spacers available should be used. Wooden dowels boiled in paraffin can be used with untuned lines but their use is not recommended for tuned lines. The wooden dowels can be attached to the feeder wires by drilling small holes in the dowels, then binding them to the feeders with wire.

It should be kept in mind that the ends of tuned feeders or the ends of the antenna are points of maximum voltage. It is at these points that the insulation is most important, and Pyrex glass, isolantite or steatite insulators with long leakage paths are recommended. Glazed porcelain also is good. Insulators should be cleaned once or twice a year, especially if they are subjected to much smoke and soot.

It is hardly possible to give practical instructions for the suspension of the antenna since

the methods used will vary so widely in individual instances. In most cases poles are desirable to lift the antenna clear of surrounding buildings but in some locations the antenna is in the clear when strung from one chimney to another or from a chimney to a tree. Small trees are not usually satisfactory as points of suspension for the antenna on account of their movements in windy weather. If the antenna is strung from a point near the center of the trunk of a large tree this difficulty is not as serious. If the antenna must be strung from one of the smaller branches, it is best to tie a pulley firmly to the branch and run a rope through the pulley to the antenna, with the other end of the rope connected to a counterweight near the ground. The counterweight will keep the tension of the antenna constant, even when the branches sway and when the rope tightens and stretches under varying climatic conditions.

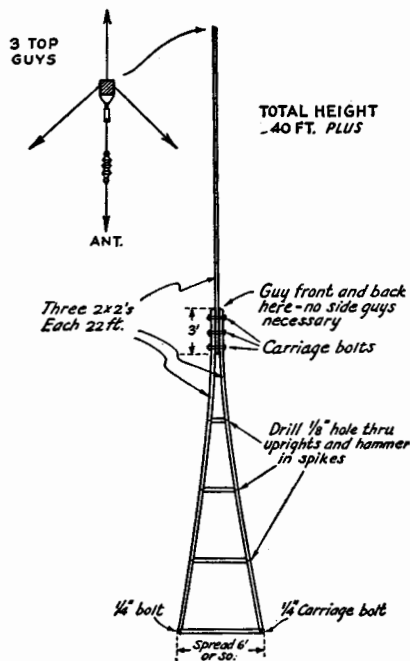

Fig. 2501 — Details of a 40-foot mast suitable for erection in locations where space is limited.

The Radio Amateur's Handbook

● ANTENNA MASTS

A very simple and inexpensive mast is shown in Fig. 2501. This design has been very popular and is satisfactory for heights up to 35 or 40 feet. In addition to the 2" x 2" lumber, the only materials required are 5 1/4" carriage bolts 5 1/2" long with washers, a few spikes, about 300 ft. No. 12 galvanized iron wire and several small strain insulators. These should be used about every 10 or 12 feet to break the guy wires into sections. Clear, sound lumber should be selected. The mast may be protected by two or three coats of house paint or, preferably, aluminum paint.

If the mast is to stand on the ground, a couple of stakes should be driven to keep the bottom from slipping. The mast may be "walked up" by a pair of helpers. If it is to go on a roof, first stand it up against the side of the building and then hoist it, from the roof, keeping it vertical. The whole assembly is light enough for two men to perform the complete operation — lifting the mast, carrying it to its permanent berth and fastening the guys

— with the mast vertical all the while. It is therefore entirely practicable to put up this kind of mast on a small flat area of roof that would prohibit the erection of one that had to be raised vertical in its final location.

A heavier mast for greater heights (W1ALJ) is shown in Fig. 2502. It can be made forty to sixty feet high, requires only two back guys forming a tripod with the antenna and is cheap to construct.

The material required is as follows:

- 1 — 6" x 6" 9 feet long
- 2 — 4" x 4" 14 feet long
- 1 — 4" x 4" 20 feet long
- 2 pieces 20 feet long, 1" thick, 3" at bottom end, tapered to 2" at top
- 1 — Top piece 2" x 1" 6 feet long

Lapping bolts:

- 4 — 5/8" x 14"
- 3 — 1/2" x 7"
- 3 — 3/8" x 3 1/2"

Reinforcement bolts to prevent splitting at ends of sticks:

- 6 — 1/2" x 4 1/2"
- 1 — 1/2" x 7"
- 2 — 1/4" x 3 1/2"
- 3 — 1/4" x 2 1/2"

Each bolt requires two washers. Large square washers may be used on the lapping bolts and regular round washers on the reinforcement bolts. The bolts and washers should preferably be galvanized.

The cost of all material for this mast is about \$12.

Constructional Hints

1. Saw sides of bottom piece (6 x 6) to accommodate lapping of the two 4 x 4's. See detail sketch.
- NOTE. — Most so-called 4 x 4's are usually about 3 5/8" square.
2. Shed the tops of all pieces to allow rain to run off.
3. Bore necessary bolt holes in all pieces.
4. Install the reinforcement bolts with washers in ends of all pieces where necessary and tighten.
5. Lay all pieces on level ground in mast formation and insert bolts. Tighten all bolts except those for lapping the first two parallel 4 x 4's with the second 4 x 4.
6. Cut and fit the intermediate reinforcement pieces used in the two parallel sections and nail them permanently in place. They should be about one foot long.

Fig. 2502 — A 50-footer of husky construction. Only two guy wires at the top are required.

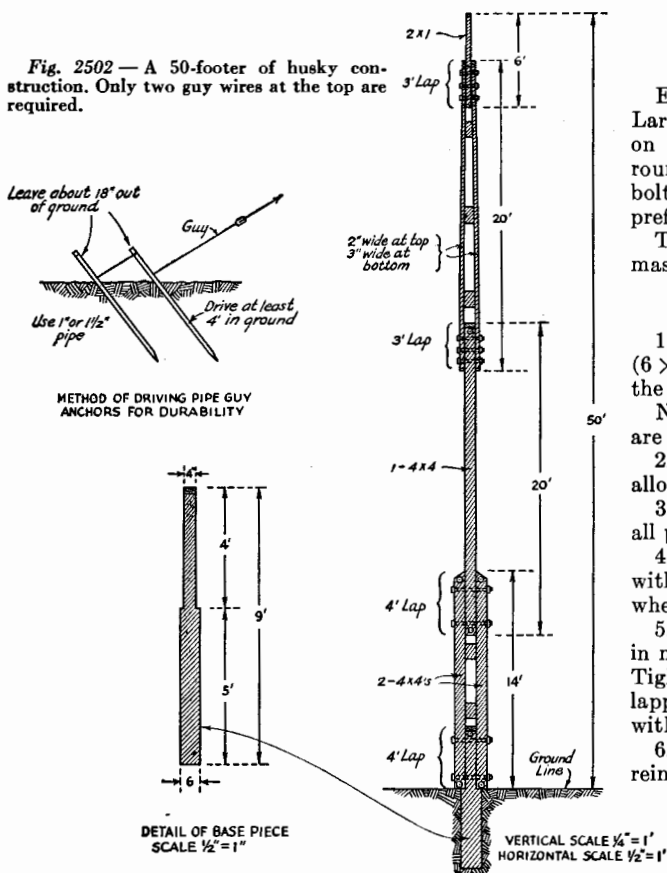

Antenna Construction

7. Get three or four soap boxes for horses and paint mast if you desire. Light gray makes a fine-looking mast.

8. Use at least $\frac{1}{2}$ " rope for raising any antenna and install a good pulley on the top stick.

Guying of this type of mast is neither complicated nor costly. No. 14 or 12 steel wire will suffice for an ordinary single wire antenna. Small egg type strain insulators are best for breakers due to lapping of guy wire holes. They should be spaced about 12 feet.

As previously mentioned, only two back guys are necessary, each of these spaced 120 degrees from the antenna.

There are numerous methods of anchoring the guys but the most common are trees, fences and pipes driven in the ground. The latter method is shown. The guy anchors should be installed at least 30 feet from the base of the mast and driven at least four feet into the ground.

Installation

Dig hole 5 feet deep for 6×6 . This piece may be set in cement or reinforced by filling hole with rocks and tamping dirt around them. Use level to make sure base piece is vertical. Raise first two parallel 4×4 's, and bolt in place to base piece. Raise remaining 40-foot section to vertical position beside the parallel 4×4 's. It is not heavy and one man can easily accomplish this. While a brother ham holds the 40-foot section in place, climb a stepladder and tie a piece of rugged rope or wire loosely around the whole assembly about 2 feet down from the top of the parallel 4×4 's. Hold this in place

with a staple driven into one of the parallel 4×4 's. This will serve as a safety guide while raising the 40-foot section vertically. Two men take one guy each and walk in opposite directions from base of pole to a distance of about 40 feet. Get a good hold under the bottom of the 40-foot section and raise vertically. Men on ends of guys should allow plenty of freedom and yet not allow top to sway more than 12 inches or so. When the bottom of this section reaches your waist, start walking up stepladder. If you are rugged, you can handle mast with one hand and hang on to stepladder with the other. However, if you are not rugged, someone should help you during this operation. When the 40-foot section reaches the proper height, slide its base between the 4×4 's and insert the two bolts for this lap. Tighten nuts and the mast is complete.

The mast shown in Fig. 2503 was put up by W9LM at a cost of no more than \$8. Only four persons were needed to put it up and no guy wires were used. It has stood up for a number of years through some strong winds.

A used telephone pole was purchased and delivered for \$5. A hole 6 ft. deep was dug for it. About 2 ft. from the top of the pole a $\frac{1}{2}$ " hole was bored. The lower section was raised by hand until ladders could be placed under it which served as gin poles. The top section consisting of 2×4 's was assembled on the ground and a $\frac{1}{2}$ " hole bored about 5 ft. from the lower end of the top section. The lower end of the top section was loosely bolted to the top of the lower section and swung up into position, as shown in the sketch, and spiked in place.

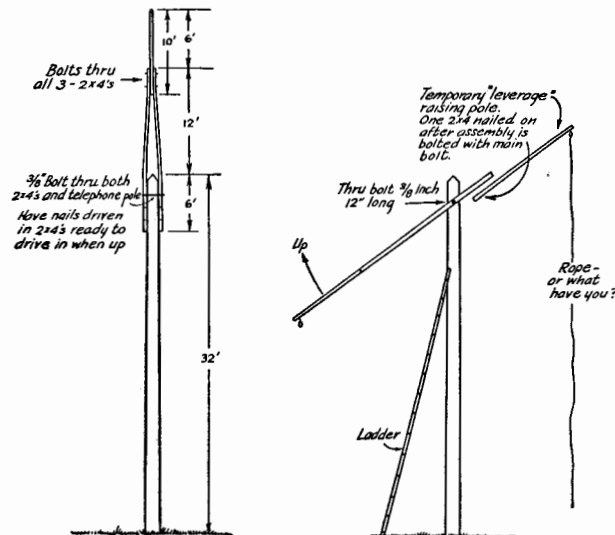

Fig. 2503 — This type may be carried to a height of 50 feet or more. No guy wires are required.

● ROTARY BEAM CONSTRUCTION

While the power gain given by a directive antenna unquestionably is desirable, it is only obtained through a decrease in the power radiated in unfavored directions, and therefore limits the "all-around" communication possibilities of the station. To overcome this, many amateurs mount the simpler types of directive antennas in such a way that the antenna can be rotated to shift the direction of the beam at will.

Obviously the use of such rotary antennas is limited to the higher frequencies if a structure of practicable size is to be used. For this reason the majority of rotary beam antennas are constructed for the 28-Mc. band, although many are in use at 14 Mc. The antenna arrangements themselves do not

The Radio Amateur's Handbook

differ from those used when the wires are fixed in position; the problems involved in the construction of a rotary beam antenna are almost purely mechanical.

The antenna elements may be arranged either vertically or horizontally as desired. At the frequencies for which most rotary antennas are built, horizontal polarization is usually more desirable, particularly in reception. This is because of the fact that the arriving waves usually are horizontally polarized and because electrical noises, bothersome at the high frequencies, are vertically polarized. With horizontal elements it is therefore possible to get a better signal-to-noise ratio under average conditions. However, it must not be thought that the vertically-polarized antenna suffers from a lack of effectiveness — it is simply that where circumstances permit a choice, horizontal polarization is to be preferred. It is true, also, that the mechanical construction of a rotating antenna with vertical elements often is simpler than that of a horizontal antenna having the same electrical arrangement.

The problems in rotary beam construction are those of providing a suitable mechanical support for the antenna elements, furnishing a means of rotation, and in attaching the transmission line so that it does not interfere with the rotation of the system. Quite simple and inexpensive arrangements can be used, although they may not be as convenient in operation as the more elaborate structures which some amateurs have built. An extremely simple method is indicated in Fig. 2504. The particular antenna shown is an extended double Zepp with a parasitic reflector, the elements being assembled on wooden spreaders and suspended vertically from any convenient point. The system is simply moved by hand to the desired position, the two-pound weights acting as anchors to hold it in place. Of course the ropes between the weights and lower spreader should be long enough to allow the weights to lie on the ground. The swivel at the top permits easy rotation without binding or twisting. The height required for this particular antenna, which is designed for the 28-Mc. band, is approximately 50 feet. It could be hung from a regular horizontal antenna of appropriate height. A similar suspension could readily be used for a half-wave antenna with director or reflector, in which case the antenna assembly would be only 25 feet or so long. (Bib. 1)

Fig. 2505 shows another mechanical arrangement for vertical elements. The antenna, which is a vertical section of metal tubing, is fixed in position and is provided with a director and reflector which rotate about it. The advantage of this arrangement is that no provision need be made for special contacts between the antenna and the feeder system, since the

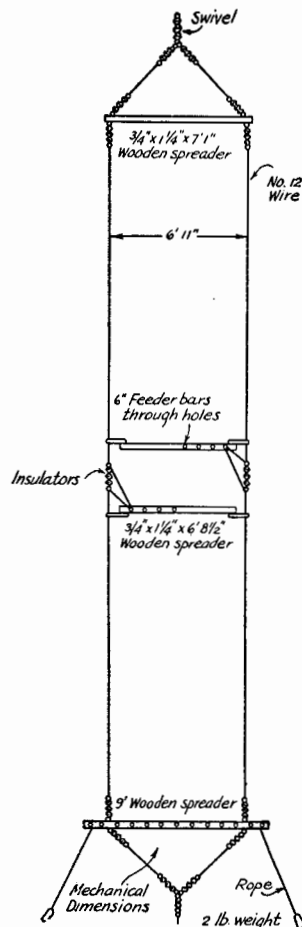

Fig. 2504 — A simple arrangement for a rotatable directive antenna. It may be suspended from any suitable support, such as another antenna, having the requisite height. The antenna shown is a 28-Mc. extended double Zepp with reflector.

position of the antenna is fixed. A rope and pulley arrangement provides rotation from the operating room, so that when a signal is picked up the antenna can be rotated rapidly to the position which gives maximum response. It is then also pointing in the proper direction for transmission to the same station. The antenna system shown can be varied in details, of course; for instance, close spacing might be used between the parasitic elements and the antenna to give somewhat greater gain. (Bib. 2)

When elements are suspended horizontally it is necessary to make a supporting structure, usually of light but strong wood. In such case, also, it is desirable, both to simplify the structure and to provide rigidity in the elements, to make the elements of light-weight metal tubing. Dural tubes often are used, and thin-walled corrugated steel tubes with copper coat-

Antenna Construction

ing also are available for this purpose. The elements usually are constructed of several sections of telescoping tubing, making length adjustments quite easy.

An easily-constructed supporting frame for a horizontal rotary beam is shown in Fig. 2506. It may be made of 1 by 2 lumber, preferably oak for the center sections, with white pine or cypress for the outer arms. The self-supporting tubing antenna elements are intended to be mounted on stand-off insulators on the arms marked E. The square block at the center (A) may be fastened to the pole by any convenient means. The dimensions of such a structure will, of course, depend upon the type of antenna system used. It is particularly well suited to a half-wave antenna with a single director or reflector on 14 Mc., or a three-element beam on 28 Mc. (Bib. 3)

Various means of rotation and of making contact to the transmission line have been devised. One method is shown in Fig. 2507. In this case the supporting pole is rotated by the chain and sprocket arrangement shown, with the base of the pole resting on a bearing. Feed-

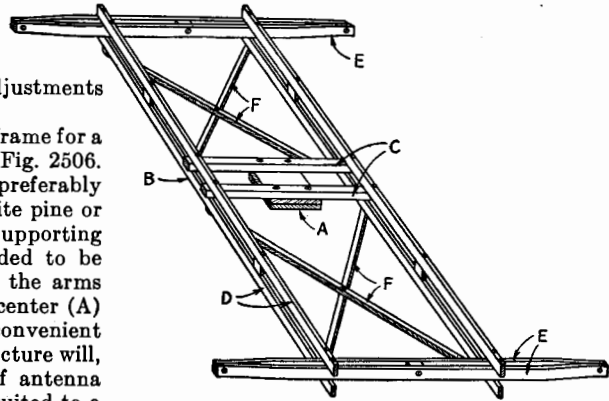

Fig. 2506 — Easily-built supporting structure. Made chiefly of 1 by 2's, the structure is strong yet light-weight. Antenna elements are supported on stand-off insulators on the "E" arms. The length of the "D" sections will depend upon the element spacing.

ers are brought down the pole from the antenna to a pair of wire rings, against which sliding contacts press. (Bib. 4)

Parts from junked automobiles often pro-

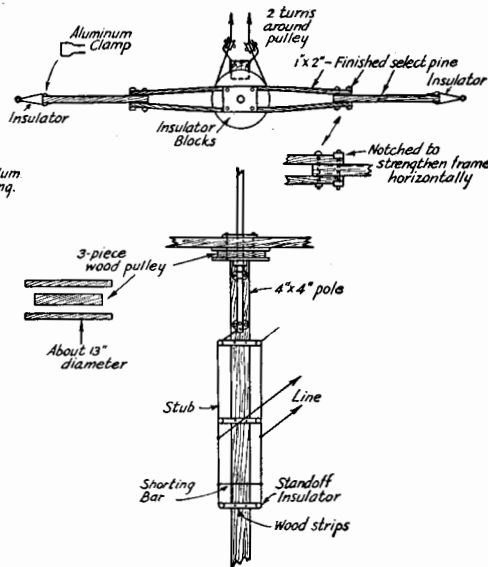
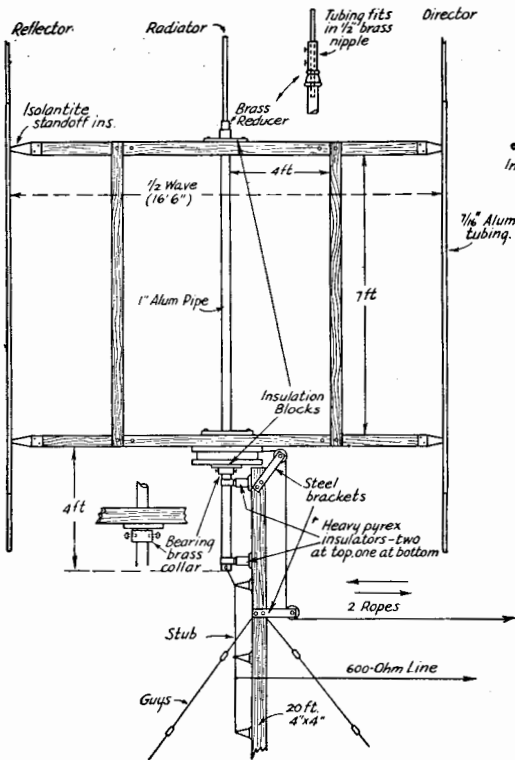

Fig. 2505 — A practical vertical-element rotatable array for 28 Mc. No special feeder-contact mechanism is needed, since the driven antenna is fixed. The reflector and director, parasitically excited, rotate around it. Close-spaced elements may be used if desired.

The Radio Amateur's Handbook

vide gear trains and bearings for rotating the antenna. Rear axles, in particular, can readily be adapted to the purpose. Some amateurs use motor-driven rotating mechanisms which, although complicating the construction, simplify the remote-control of the antenna. More or less elaborate indicating devices to show, in the operating room, the direction in which the

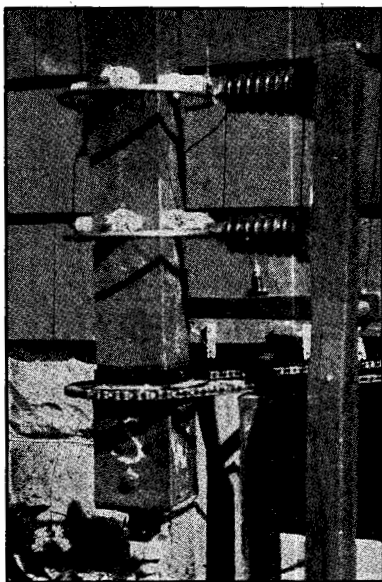

Fig. 2507 — One form of rotating mechanism. A bicycle sprocket and chain turn the pole which supports the beam antenna. Feeder connections from the antenna are brought to the metal rings, which slide against spring contacts mounted on the large stand-off on the short pole.

antenna is pointed, often are used with motor-driven beams.

Generally speaking, a rotary beam antenna is useful for only one band, and if multi-band operation is contemplated an additional antenna or antennas of conventional construction must be installed. A few systems, however, are adaptable to operation on two bands. The arrangement of Fig. 2406-B, Chapter 24, for instance, can be used for this purpose.

The full benefit of a rotating directive antenna is realized only when the system is unidirectional, since such an antenna offers the maximum possibility of reducing interference and noise in reception. An incidental advantage to other amateurs is the fact that a unidirectional antenna also reduces interference to other stations not along the line of transmission. Bidirectional systems, while somewhat less advantageous from this standpoint, are, however, somewhat easier to build mechanically, because it is only necessary to rotate the

antenna through 180 degrees rather than 360. Feeder contact is not so difficult in such a case. When the antenna is designed for 360-degree rotation, it is preferable to have the feeders arranged so that continuous rotation is possible, rather than to have a stop at some point on the circle. This avoids the necessity for re-tracing almost the whole circle when it is desired to move the antenna the few degrees from one side of the stop to the other.

Time spent in adjustment of the rotary beam for maximum results, particularly in obtaining the best front-to-back ratio, is well repaid. The fact that the antenna is rotatable facilitates this process, since any convenient receiving location can be used for checking field strength.

● THE RECEIVING ANTENNA

Because of the high sensitivity of modern receivers a large antenna is not necessary for picking up signals at good strength. Often it will be found that the receiving antenna in the amateur station is an indoor wire only 15 or 20 feet long.

On the other hand, the use of a tuned antenna unquestionably improves the operation of the receiver because the signal strength is greater in proportion to the stray noises picked up by the antenna than is the case with the antenna of random length. Also, since the transmitting antenna is usually given the more choice location, it can be used to great advantage for receiving, especially on the DX bands, and always when a directive antenna is used. A change-over switch or relay connected in the antenna leads can be used to transfer the connection from the receiver to the transmitter while the transmitter is on the air. For best results, an antenna tuning unit, as shown in Chapter 8, should be used at the receiver.

If a separate receiving antenna is preferred, a doublet antenna of the type shown in Fig. 2508 will give very good results. The length of the lamp cord transmission line may be anything convenient. The antenna itself should be a half-wave long for the frequency band most

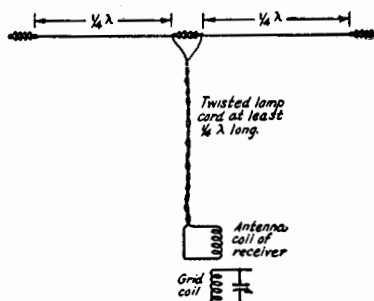

Fig. 2508 — Doublet receiving antenna.

Antenna Construction

used; despite the fact that the antenna is resonant for only one band, it will give good results on others as well. A popular length is 65 feet or so, designed to resonate in the 7000-kc. band.

The increasing popularity of short-wave broadcast receiving antennas has led to the development of many excellent commercial types available in kit form at reasonable prices. Designs such as the "Double-Doublet" and the "V Doublet" perform effectively for amateur work at 14 Mc. and lower frequencies.

● DUMMY ANTENNAS

In tuning the antenna system to the transmitter the antenna ammeter's chief function is that of providing a means for comparing the effects of different adjustments. The actual power output must be measured by adopting a different method. The simplest of these is that involving the use of a non-radiating or "dummy" antenna.

Such a dummy antenna should be part of the equipment available in all good stations. By its use, during periods of adjustment and tuning of the transmitter, much unnecessary interference with the communication of other stations may be avoided.

The dummy antenna is a resistance of suitable value capable of dissipating in the form of heat all the output power of the transmitter. One of the most satisfactory types of resistors for amateur work is the ordinary incandescent electric lamp. Other non-inductive resistors of sufficient power-dissipating capacity can be used, however.

Three circuits for use with dummy antennas are given in Fig. 2509. The first of these is for use with a low-resistance dummy — say 25 ohms or less. The resistor is connected in series with a tank circuit which tunes to the same frequency as the transmitter, and which is coupled inductively to it. If the value of the resistance is known accurately — measurement is difficult, however, because of skin effect at high frequencies — the power may be determined by measuring the radio-frequency cur-

rent in the resistor and applying Ohm's Law ($W = I^2 R$). The resistor must be noninductive. Suitable resistors are available commercially.

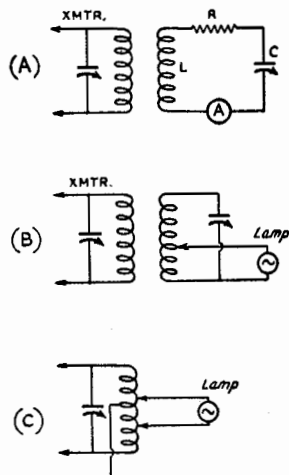

Fig. 2509 — Dummy antenna circuits.

Incandescent bulbs, which in the 115-volt sizes have a resistance of 75 ohms or more at operating temperature for ratings of 150 watts or less, will work more satisfactorily in either of the other two circuits. The lamp should be equipped with a pair of leads, preferably soldered right to the terminals on the lamp base. The number of turns across which the lamp is connected should be varied, together with the tuning and the coupling between the dummy circuit and the transmitter, until the greatest output is obtained for a given plate input.

In using lamps as dummy antennas, a size corresponding to the expected power output should be selected so that the lamp will operate near its normal brilliancy. Then when the adjustments have been completed an approximation of the power output can be obtained by comparing the brightness of the lamp with the brightness of one of similar power rating in a 115-volt socket.

Bibliography

- 1 Wallace, "A Ten-Meter Rotatable Alford Beam," *QST*, July, 1938.
- 2 Neuenhaus and Schreiner, "A Continuously-Rotatable 28-Mc. Beam," *QST*, March, 1938.
- 3 Lynch, "Some Thoughts on Rotary-Beam Antennas," *QST*, October, 1938.
- 4 Blaho, "Simplifying the Rotary Antenna Mechanism," *QST*, October, 1938.

Introduction to U.H.F.

A Brief Survey of U.H.F. Wave Propagation, Equipment and Possibilities

IN AMATEUR work, the ultra-high-frequency region is considered to include the 56- to 60-Mc. band and all higher frequency bands available for amateur use. The 28- to 30-Mc. band is not normally considered to be a part of the ultra-high-frequency region. However, it is often desirable to include dimensions for 28-Mc. operation of some of the 56-Mc. gear because many amateurs will wish to work the two bands with the same equipment. The 56-Mc. equipment converted to 28-Mc. work will usually be more effective than will lower-frequency apparatus cut down to work at 28 Mc.

Wave-propagation phenomena change rapidly as the frequency is increased above 28 Mc. Barring extremely exceptional conditions, the frequency limit at which sky waves are sufficiently bent, in the F_2 layer of the ionosphere, to be returned to earth lies in the region of 40 megacycles during the favorable part of the sunspot cycle. It may be well below 28 Mc. during the unfavorable part of the cycle. The 28-Mc. band, then, is characterized by periods, extending over several years, when fully reliable communication over long distances is possible, and by similar periods of shorter length when long distance communication is almost non-existent. During the latter periods the transmission characteristics are in many respects similar to those customarily found on 56 Mc.

Direct-Ray Transmission

Transmission by means of the F_2 layer in the 56-Mc. band is so extremely rare that it can be neglected for practical communication. There are three known ways in which waves in this frequency region are propagated. The first is by direct, or nearly direct rays, whose paths are very similar to those of light rays. The range in this case is practically the same as the visual range from the antenna, and for this reason transmission of this type is known as "line-of-sight" transmission. Just as in the case of visual distances, the transmitting and receiving range depend upon the height of the transmitter and receiver above the surrounding territory, and on the contour of the ground between the transmitting and receiving points. The actual range of line-of-sight transmission extends about 10% beyond the optical horizon, on 56 Mc.

Lower-Atmosphere Transmission

During the latter part of 1934, experimental work at A.R.R.L. Headquarters served to establish that ultra-high-frequency waves are bent very appreciably in the lower atmosphere under certain atmospheric conditions. This work indicated that, on occasions when warm, moist tropical air was overrunning relatively cold and dry Polar air, communication could be had, even from low-lying stations, over distances of a hundred and sometimes two hundred miles. It was also shown that considerable bending of the waves in the lower atmosphere occurs at all times when a layer of warm air overruns a layer of colder air. Since this effect is to be found almost every night, one can expect to find that communication with points beyond the visible range is prone to become much more effective at night than during the day.

Sporadic E-Layer Transmission

Occasionally patches of densely ionized atmosphere occur at heights somewhat lower than that of the normal E layer, and these "sporadic E " layer patches often are capable of refracting 56-Mc. waves sufficiently to return them to earth. Since the layer height is comparatively low, the distances which can be covered are not comparable to those resulting from F_2 layer transmission, but are limited to a maximum of about 1200 miles for one-hop transmission. The "sporadic E " layer is not continuous, and circumstances which result in a patch appearing at exactly the right spot to make communication possible between two stations are largely fortuitous. Two-hop transmission over longer distances is rare, although it has been known to occur. Conditions suitable for 56-Mc. transmission via the sporadic E layer occur most frequently during the summer months. Contrary to regular ionosphere transmission on the lower frequencies, there is no observed variation with time of day, and good conditions for this type of transmission are likely to exist in either daylight or darkness.

Higher Frequencies

Less has been established regarding transmission characteristics on the 112-Mc. band than is known about 56-Mc. transmission.

Introduction to U.H.F.

There are no known instances of sporadic *E*-layer refraction in the 112-Mc. band, but the possibility that it does occur cannot be ruled out until a great many stations, in different parts of the country, have made continuous observations over long periods of time. Amateur operators have the opportunity to contribute significant and greatly needed information on this point. It is urged that special efforts be made to listen and transmit in the 112-Mc. band when conditions are favorable for "DX" work on 56 Mc., since it is at these times that sporadic *E* refraction would occur on 112 Mc.

Bending in the lower atmosphere takes place on 112 Mc. in much the same way as on 56 Mc., and experiment indicates that the same ranges are possible. This question, however, has not been thoroughly investigated, and more data resulting from more widespread activity on the band would be of value.

Direct-ray or line-of-sight transmission on 112 Mc. is equivalent to that on 56 Mc. This also is true of frequencies in the 224-Mc. band. On the latter frequency, however, experimental confirmation of lower atmosphere bending is meager, and the opportunity exists for pioneering work along these lines.

Opportunities for important discovery lie in the ultra-high-frequency region, particularly in the little-explored frequencies above 112 Mc. The lack of guide-posts is a fascinating incentive to exploration on the part of the experimentally-inclined amateur.

Antennas

The familiar forms of antennas are in use on the ultra-high-frequencies, much reduced in linear dimensions but operating on the same principles. The smallness of the antenna offers an excellent opportunity for the construction of effective directive systems, with a wide range of choice in the types to use.

Experience has shown that a vertically-polarized antenna gives better results in line-of-sight transmission, insofar as signal strength is concerned, than one horizontally polarized. Most of the man-made noise which is prevalent in the lower ultra-high-frequency region (56 Mc.) is, however, vertically polarized, and can be considerably reduced in reception by using a horizontally polarized antenna. The question of whether horizontal polarization would not, on that account, be better on the whole for amateur work has not been thoroughly explored. In line-of-sight and lower atmosphere transmission, it is essential for maximum results that the same polarization be used at both transmitter and receiver. For transmission by means of the sporadic *E* layer, however, either type of polarization seems equally effective,

regardless of the kind used at the transmitter or receiver, since the polarization frequently shifts when the wave is refracted in the layer.

Equipment

The equipment used for 56-Mc. work resembles that described earlier in this volume for the lower frequencies. Transmitters are usually crystal-controlled, while in the receiving field the super-heterodyne is outstandingly superior to other types. Some modifications in design and layout are necessary to secure maximum performance, but in general the circuits and construction are straightforward.

At 112 Mc. and higher a different picture prevails. Here there are no stringent requirements as to frequency stability, so that very simple equipment is the order of the day. Ordinary tuned circuits consisting of coils and condensers are inefficient, and frequently are replaced by resonant-line circuits which bear no resemblance to their conventional equivalents. These high-*Q* linear circuits, greatly superior to ordinary coil-condenser tanks, are within the realm of practicality on ultra-high frequencies where dimensions in terms of wavelength can be expressed in inches rather than meters. They can be applied both to transmitters and receivers, and contribute greatly to making tubes of ordinary construction useful. Even so, the experimenter must pick his tubes with care if good results are to be secured — or even any results at all.

Frequency Modulation

Although frequency modulation is forbidden in the lower-frequency bands, it is specifically permitted in the 58.5- to 60-Mc. and 112- to 116-Mc. ranges. It is, however, stabilized f.m. with no appreciable amplitude modulation, and as such has several advantages, chief of which are its noise-reduction characteristics with proper receivers and its negligible audio power requirements. It is one of the most fertile fields at the present time for amateur experimentation, and demands the attention of every serious u.h.f. worker.

Amateur Television

Television is allowed in the 112-Mc. and higher-frequency bands. With the development of inexpensive picture pick-up tubes (Iconoscope) and viewing c.r. tubes (Kinescope), considerable impetus has been given to amateur television recently. Although undoubtedly destined to become an important part of amateur communication in the future, it is at present too specialized a field to be treated in the *Handbook*. Those interested in the subject will find many interesting articles in the 1938, 1939 and 1940 issues of *QST*.

U.H.F. Receiving Equipment

Converters — Superheterodynes — Superregenerative Receivers

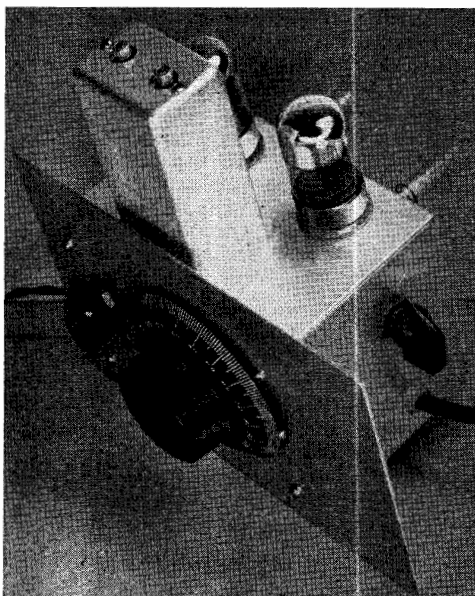

Fig. 2701 — The 112-Mc. converter uses a 7A4 oscillator and a 1232 mixer. The panel dial is the oscillator tuning dial; the panel knob is the mixer tuning control. The knob on the side adjusts the oscillator band-set condenser.

IN ESSENTIAL principles, modern receiving equipment for the 28- and 56-Mc. bands does not differ from that used on lower frequencies. In view of the higher frequency there are, of course, certain constructional precautions which must be taken to ensure good performance. The 28-Mc. band serves as the meeting-ground between those frequencies ordinarily termed "communication frequencies" and the ultra-highs, and it will be found that most of the receivers described in Chapter Eight are capable of working on 28 Mc. In this chapter will be presented receivers and converters capable of good performance on 56 Mc. and higher.

Present regulations require that transmitters working on all frequencies below 60 megacycles must meet similar requirements respecting stability of frequency and freedom from frequency modulation. It is thus possible to use

receivers for 56 Mc. having the same selectivity as those designed for the lower frequencies. This order of selectivity is not only possible but desirable, since it makes possible a considerable increase in the number of transmitters which can work in the band without interference, as compared to broad-tuning receivers. Also, high selectivity greatly improves the signal-to-noise ratio, both in the receiver itself and in the response to external noise. This means that the effective sensitivity of the receiver can be considerably higher than is possible with non-selective receivers.

Sufficiently-high selectivity can only be obtained by using the superheterodyne type receiver. This type also offers the highest degree of stability, which is an extremely important consideration in ultra-high frequency work. A receiver which will not "stay put" on one frequency requires continual retuning, which is an operating disadvantage, and the tuning is critical if the selectivity is fairly high. It is difficult to make a simple regenerative receiver sufficiently stable for c.w. reception on 56 Mc., and its selectivity is very poor. Until the transmitter frequency-stability requirements were extended to the 56-Mc. band the superregenerative type receiver was highly popular, but its selectivity also is poor and the sensitivity does not compare with that of a good superhet. The superregenerative receiver has the advantage of low cost, however, and for that reason is still used to some extent. It is, however, excellent for the 112-Mc. band and practically the only receiver used on 224 Mc.

A superhet receiver for 56-Mc. work should use a fairly high intermediate frequency so that image response will be reduced. At 56 Mc., for instance, a difference between signal and image frequencies of 900 kc. (the difference when the i.f. is 450 kc.) is a very small percentage of the signal frequency, consequently the response of the r.f. circuits to the image frequency is very nearly as great as to the desired signal frequency. To get discrimination against the image equivalent to that obtained at 3.5 Mc. with a 450-kc. i.f. would require for 56 Mc. an i.f. 16 times as high, or about 7 Mc., if the circuit Q's were the same in both cases. However, the Q of a tuned cir-

U.H.F. Receiving Equipment

cuit at 56 Mc. is not as high as at the lower frequencies, chiefly because the tube loading of the circuit is considerably greater. As a result, still higher intermediate frequencies are desirable, and a practical compromise is reached at an i.f. of about 10 Mc.

Since high selectivity cannot be obtained with a reasonable number of circuits at 10 Mc., the double superhet principle is commonly employed. The 10-Mc. frequency is changed to an i.f. of the order of 450 kc. by a second oscillator-mixer combination. Thus the receiver has two intermediate frequencies, at both of which amplification takes place before the signal is finally rectified and changed to audio frequency.

Very few amateurs build complete 56-Mc. superhet receivers along these lines. General practice is to use a conventional superhet receiver to handle the 10-Mc. output of a simple frequency-converter. Thus a regular communications type receiver — or even an all-wave broadcast receiver — can be used with excellent effect on 56 Mc. with the addition of a relatively simple and inexpensive "converter." Since most amateurs have communications receivers, the construction of a good superhet for 56 Mc. is a relatively simple matter.

From a practical aspect, superregenerative receivers may be divided into two general types. In the first the quenching voltage is

developed by the detector tube itself — so-called "self-quenched" detectors. In the second, a separate oscillator tube is used to generate the quench voltage. The self-quenched receivers have found wide favor in amateur work. The simpler types are particularly suited for portable equipment where the apparatus must be kept as simple as possible. However, it is our strong recommendation that the separately quenched type be used in all cases where the ultimate performance is expected. One enormous advantage of the separately quenched type is that it is readily possible to adjust the operating conditions so that the receiver is extremely sensitive even under conditions when relatively little hissing or "mush" noise is had. In the separately quenched superregenerative detector it would appear to be of little consequence just how the quench voltage is introduced into the circuit providing the voltage is of the correct order and that the quench frequency is something near the optimum value. Many amateurs have "pet" circuits which are claimed to be superior to all others. The probability is that the arrangement of their particular circuit has led to the use of correct operating conditions. It is certainly a fact that any of the various separately quenched circuits can be made to operate in substantially the same fashion by careful adjustment. Likewise, the self-quenched circuits are all capable of a somewhat similar performance. The latter, however, though very simple in appearance, require particularly careful handling in order to obtain smooth operation and freedom from howling and generally irregular performance.

● U.H.F. CONVERTERS

If the amateur already has a communications receiver, or even a fairly decent all-wave b.c. set capable of tuning to 5 or 10 Mc., there is little or no need for building a special u.h.f. receiver, particularly for 56 Mc. It is much easier to build a converter and work the converter into the already-existing receiver. The output transformer of the converter is tuned to the same frequency as the receiver (5 or 10 Mc.) and the signal is coupled through a low-impedance line to the input of the receiver in much the same manner that link coupling is used in a transmitter. All of the tuning is done with the converter, and the gain is adjusted to a suitable level by means of the gain control on the receiver into which the converter is working.

A Converter for 56 and 112 Mc.

The converter shown in Figs. 2701, 2702, 2704, 2705 and 2706 uses a 1232 loktal tube for the mixer and a 7A4 for the oscillator. By

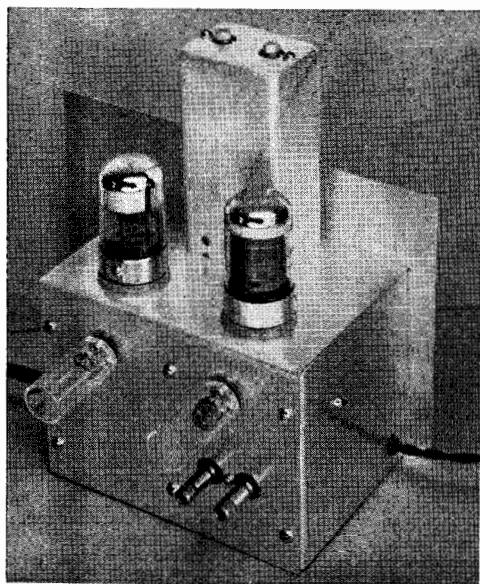

Fig. 2702 — A rear view of the converter shows the two plug-in coils and the antenna terminals. The wire leading off at the left is the battery cable; the twisted pair on the right carries the output to the i.f. amplifier.

The Radio Amateur's Handbook

grouping the tuning condenser, coil and tube socket closely together, it is a relatively simple matter to achieve low-enough circuit capacities to work readily on 112 Mc. As can be seen from Fig. 2703, the grid of the 1231 mixer is tapped down on the coil, to reduce the loading on the circuit and obtain a better gain in the stage. The plate-tickler circuit is used in the oscillator, so that the cathode can be grounded directly and thus give a minimum of hum to the signal.

The oscillator tuning condenser is a 15- μ fd. condenser from which several plates have been removed, and this is paralleled by a 35- μ fd. band-set condenser. With this type of band-spread system, the converter can be set to the desired frequency band, the mixer condenser turned to the point where the noise is greatest, and then the tuning is all done with the small oscillator condenser. When a signal has been tuned in, the mixer can be peaked again, but it

Fig. 2703 — Wiring diagram of the u.h.f. converter.

- C_1 — 15- μ fd. midget variable (Hammarlund HF-15).
 C_2 — 35- μ fd. midget variable (Hammarlund HF-35).
 C_3 — 10- μ fd. midget variable (Hammarlund HF-15 with one stator and one rotor plate removed).
 C_4 — 100- μ fd. midget mica.
 C_5, C_6, C_7 — 500- μ fd. midget mica.
 C_8, C_9 — 0.01- μ fd. 600-volt paper.
 R_1 — 500 ohms, $\frac{1}{2}$ -watt carbon.
 R_2 — 125,000 ohms, 1-watt carbon.
 R_3 — 20,000 ohms, $\frac{1}{2}$ -watt carbon.
 R_4 — 10,000 ohms, 1-watt carbon.
 T_1 — 3 Mc.: 75 turns No. 30 d.s.c. closewound; coupling coil is 20 turns No. 30 d.s.c. closewound $\frac{1}{8}$ inch from ground end of coil.

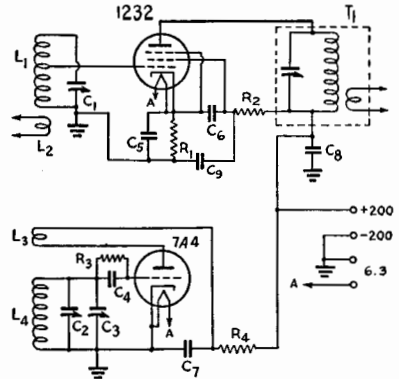

5 Mc.: 45 turns No. 30 d.s.c. closewound; coupling coil is 14 turns No. 30 d.s.c. closewound $\frac{1}{8}$ inch from ground end of coil.

The transformers are built in the Hammarlund ETU units. Both sections of the condenser are used.

- L_1 — 112 Mc.: 2 $\frac{1}{4}$ turns No. 20 enam., $\frac{3}{8}$ -inch diam., spaced diam. of wire. Grid tap at $\frac{3}{4}$ turn from top.
 56 Mc.: 4 $\frac{1}{2}$ turns No. 20 enam., $\frac{3}{4}$ -inch diam., spacewound to occupy $\frac{1}{2}$ inch. Grid tap at 1 $\frac{1}{2}$ turns from top.
 L_2 — 112 Mc.: 3 turns No. 20 enam., $\frac{1}{4}$ -inch diam., closewound one wire diameter below cold end of L_1 .
 56 Mc.: 3 turns No. 24 enam. closewound $\frac{1}{8}$ inch below L_1 .
 L_3 — 112 Mc.: 1 turn No. 20 enam. $\frac{1}{4}$ -inch diam., 3 wire-diameters below L_4 .
 56 Mc.: 1 $\frac{1}{2}$ turns No. 24 enam. closewound $\frac{1}{8}$ inch below L_4 .
 L_4 — 112 Mc.: $\frac{7}{8}$ turn No. 20 enam., $\frac{3}{8}$ -inch diam., 56 Mc.: 1 $\frac{3}{4}$ turns No. 20 enam. spaced to occupy $\frac{1}{4}$ inch.

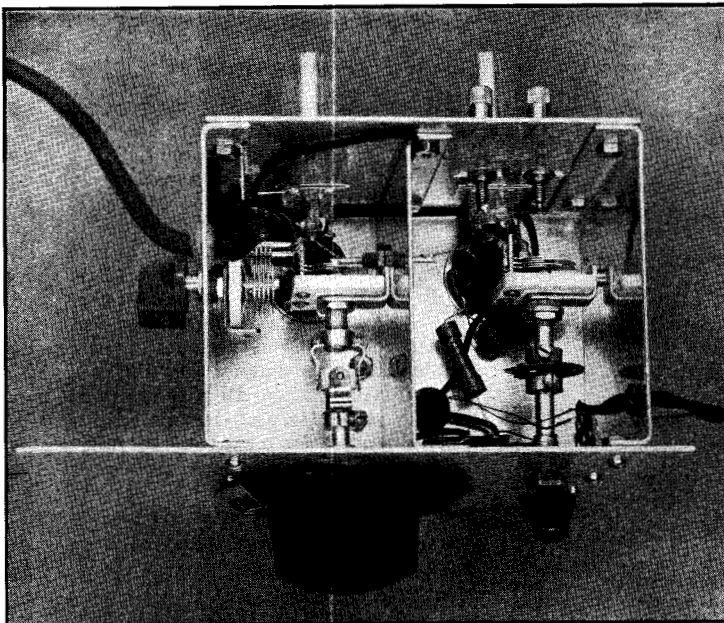

Fig. 2704 — A shot underneath the converter illustrates the arrangement of the parts. Note that in the oscillator section (on the left) the band-set and tuning condensers butt into each other for short leads. The band-set condenser is insulated from the side panel by an insulated washer, and the oscillator circuit grounds to the chassis at only one point, through the tuning condenser. The victrol through-bushing which serves as coupling between mixer and oscillator can be seen on the partition just above the oscillator tuning condenser. The bushing connects to the 1232 grid on one side and to nothing on the other.

U.H.F. Receiving Equipment

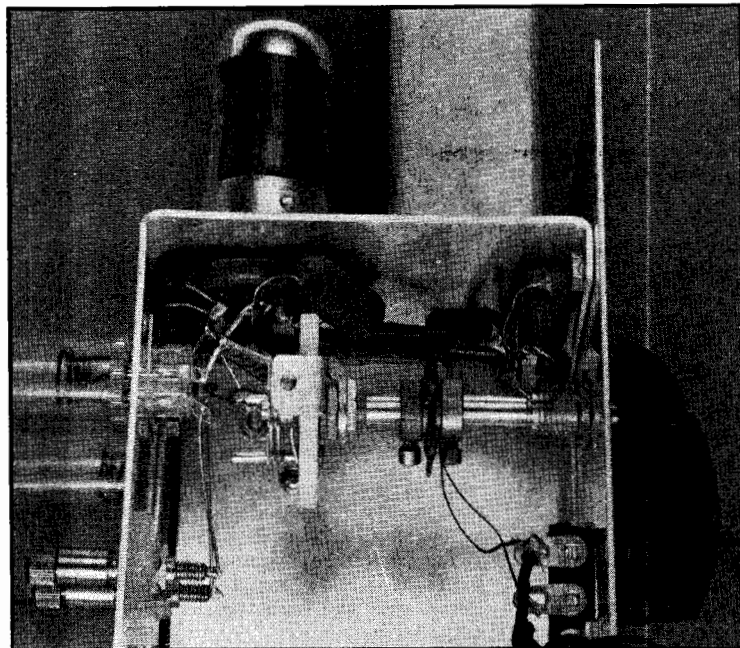

Fig. 2705 — The mixer circuit can be seen when the side panel is removed, giving an idea of the placement of the parts. The tie strip at the lower right takes the output leads from the transformer. The through-bushing can be seen just to the left of the tuning condenser, with a wire from it running to the 1232 grid.

is not usually necessary over the range of the band-spread condenser. The pulling of the oscillator by adjustment of the mixer tuning condenser is very slight because of the loose coupling.

All of the metal is 1/16-inch thick aluminum. The panel is 5½ by 8 inches, but it is longer than is absolutely necessary and could be trimmed to be only 6 inches long. The extra length was included to put the dial in the center of the panel and also to provide room for possible future switches for shifting to various i.f. amplifiers. The chassis itself is built from a piece of 5¼-inch wide metal bent to form a 3¾-inch wide top and 4-inch deep back. A ½-inch lip is bent down from the top to fasten the chassis to the panel. The two sides are made by forming shallow U's (with ½-inch sides) to fit between the panel and the back of the chassis. A shield is made and fitted under the chassis, making the oscillator compartment 2½ inches wide. This shield mounts the oscillator tuning condenser and also takes the National TPB victron through-bushing which serves as a coupling condenser between oscillator and mixer.

The coil forms are the small ¾-inch diameter Amphenol ones made of polystyrene, and the coil sockets are also of polystyrene. The coil sockets mount simply by drilling a suitable

hole and sliding the retainer rings over the sockets. The tube sockets are also made by Amphenol and mount in much the same fashion. For short leads, the oscillator socket should be mounted with the slot towards the rear of the set, and the mixer socket should be mounted with the slot towards the left-hand side of the set.

As mentioned before, the oscillator tuning condenser, C_3 , is mounted on the shield partition, and the band-set condenser, C_2 , is mounted on the right-hand side of the chassis. The band-set condenser is insulated from the metal by fiber washers so that there is only one ground point to the chassis for the oscillator circuit, that

through the oscillator tuning condenser. The mixer tuning condenser, C_1 , is mounted on the right-hand side of the chassis and grounds the mixer circuit at that point.

The oscillator tuning condenser and the mixer tuning condenser are fastened to their respective panel controls through insulated couplings, to avoid duplication of grounds.

One of the mounting screws for the tuning dial also serves to hold the top of the chassis to the panel, and another one holds the partition to the panel.

The panel and sides should be left off until all of the wiring that can be done without them has been finished. Heater leads, ground connections, by-pass condensers, and resistors can all be put in before the sides and panel are fastened. One should be a bit careful not to hold the soldering iron on the polystyrene coil sockets for any longer than is necessary to start the solder flowing, or else the socket contacts will loosen from the heat's effect on the polystyrene. A small, pointed soldering iron comes in very handy here. A lead is run from the grid of the 1232 to the through-bushing on the partition but no connection is made on the oscillator side, since the capacity between the bushing and the oscillator leads is sufficient for coupling. All r.f. leads and leads from by-pass condensers are kept short and direct.

The Radio Amateur's Handbook

The coil for the 5-meter range is wound in the usual manner on the outside of the coil forms. No trouble should be had in finding the 5-meter amateur band, since the tolerance on this range of coil is fairly wide. The only care necessary is to prevent the pins from loosening up in the forms because of the heat when soldering. The wire should be well cleaned and a spot of flux used on the tip of the pin. No attempt should be made to flow solder on the pin and wire, but a drop of solder picked up by the iron can be held against the pin for just an instant, long enough to solder wire and pin together. If the pin loosens up or moves out of place, it can be heated again slightly (by holding the soldering iron against it) and held in the proper position with long-nosed pliers. When the metal (and coil form) cools, it should be as solid as ever. If it isn't, it doesn't matter too much, since the form can still be plugged in the socket without too much difficulty.

The coils for the $2\frac{1}{2}$ -meter range are wound *inside* the coil forms. It is, however, a simple matter to adjust them, since the coil forms can first be sawed through near the base and the coils adjusted by spreading the turns. When the adjustments have been made, the coil form can be fastened together by Duco cement, and there will be no danger of the coil's being injured by handling.

The usual rule must be followed for the oscillator coil, i.e., if both grid and plate coil are wound in the same direction, the grid and plate connections come off opposite ends (in case the outside ends).

The connections on the oscillator coil, looking at it from the bottom are (starting with the oddly-spaced pin and going clockwise): plate, ground, B plus, grid and blank. In the same manner, the mixer-coil connections are grid, tuning condenser, antenna, antenna and ground. Both mixer and oscillator coil sockets are mounted with the odd pin at the top.

If the connections have been made correctly and kept short enough, no trouble should be experienced in making the oscillator oscillate in any of the ranges. For the 112-Mc. band, the oscil-

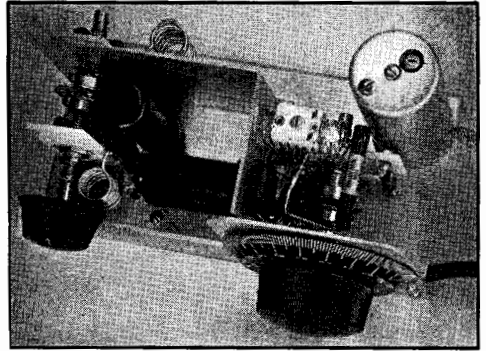

Fig. 2707 — A superhet converter for 56-Mc. reception. Designed for use with a communications-type receiver, this converter has an 1852 r.f. stage and a 6K8 mixer-oscillator. It uses a high-frequency i.f. (10 Mc.) for image reduction.

lator band-set condenser will be at minimum capacity, but will set at about mid scale for the other range, varying slightly with the i.f. used.

The converter is coupled into the i.f. amplifier through a low-impedance link, and this requires that the input transformer in the i.f. amplifier be modified by winding a number of turns about the grid coil and connecting the link to this coil. Alternatively a duplicate of the output transformer T_1 can be built and substituted for the first transformer in the i.f. amplifier. If a receiver is used for the i.f. amplifier, the output leads connect to ground and the grid cap of the mixer tube in the receiver, after the regular grid lead has been removed.

Antennas for use with the converter present the same problem that they do with any u.h.f. receiver, and your particular favorite is the one to use. A little experimenting with the antenna coil L_2 may help in giving a better match to the antenna system — the dimensions given are average values that were about right for low-impedance line input.

If signals are weak the trouble probably can be accounted for by too much or too little oscillator voltage reaching the mixer, and this can be adjusted over considerable range by moving

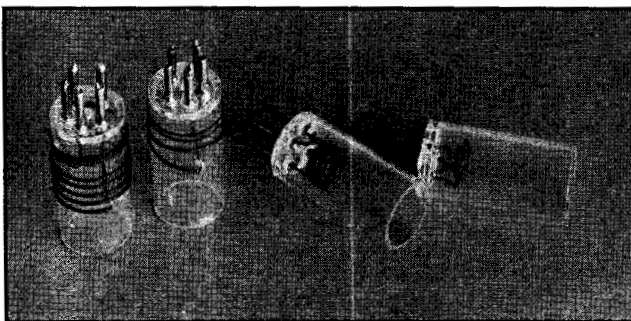

Fig. 2706 — The 112-Mc. coils (right) are self-supporting inside the coil forms, while the 56-Mc. coils are wound in the usual manner.

U.H.F. Receiving Equipment

the tickler coil L_3 closer to or farther away from L_4 . However, the adjustment does not seem to be too critical.

For maximum performance, it is suggested that a stabilized power supply be used with the converter. (*Bib. 1.*)

A 56-Mc. Converter with R.F. Amplifier

The performance of a converter can be improved by equipping it with an r.f. amplifier stage to precede the mixer. The additional amplification provided is seldom necessary with a communications receiver functioning as

tion, with C_2 directly in line with C_1 . A hole through the shield permits the two shafts to be connected by a flexible coupling. Both of the coils, and also coil L_3 , have their terminals soldered directly to the appropriate condenser lugs.

The oscillator-mixer section of the circuit is to the right of the 2½-inch partition, with the tube socket mounted on the same side. C_3 , also mounted on the partition, is located at the rear of the tube socket. The i.f. transformer, T_1 , is mounted at the right-rear corner of the chassis. The output leads from this transformer are

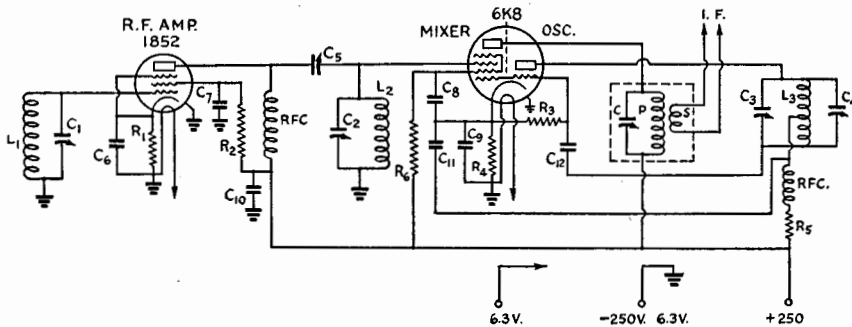

Fig. 2708 — The 1852-6K8 converter circuit.

- C_1, C_2 — 15- μ fd. midget variable (National UM-15).
- C_3 — Same as C_1 with two rotor and one stator plate removed.
- C_4, C_5 — 30- μ fd. compression-type padders.
- C_6 to C_9 , inc. — 0.005- μ fd. mica.
- C_{10} — 0.002- μ fd. mica.
- C_{11} — 250- μ fd. mica.
- C_{12} — 100- μ fd. mica.
- R_1 — 200 ohms, ½-watt.
- R_2 — 65,000 ohms ½-watt.
- R_3 — 50,000 ohms, ½-watt.
- R_4 — 300 ohms, ½-watt.

- R_5 — 20,000 ohms, ½-watt.
- R_6 — 20,000 ohms, 2-watt.
- RFC — In 1852 plate circuit, 2.5-mh. pie-wound; in oscillator circuit, solenoid type (Ohmite).
- L_1 — 6 turns No. 14, diameter ½ inch, length 1 inch.
- L_2 — 6 turns No. 14, diameter ½ inch, length ¾ inch.
- L_3 — 10 turns No. 14, diameter ½ inch, length 1¼ inches, tapped 4th turn from grid end.
- I.F. Output Transformer — P , 25 turns No. 28 d.s.c. closewound on half-inch form; S , 6 turns wound over P at bottom; C , 35- μ fd. midget variable.

an i.f. amplifier, but the improvement in both image rejection and signal-to-noise ratio is worth while. A converter with an r.f. amplifier stage is shown in Figs. 2707 and 2709. As the circuit, Fig. 2708, shows, an 1852 is used as the r.f. amplifier or preselector, and a triode-hexode converter tube, the 6K8, is used as a combined mixer and oscillator. The intermediate-frequency is 10 Mc.

The aluminum chassis measures 1 by 3½ by 7 inches. Shielding between stages is provided by the right-angle partition shown in the photograph. This partition is 2¾ inches high, and the side parallel to the front edge of the chassis is 4 inches long. The portion that supports the 6K8 is 2½ inches long. The 6K8 is mounted at the bottom of the shield, with the grid cap facing the left end of the base.

The 1852 grid tuning condenser, C_1 , and coil, L_1 , are mounted to the rear of the 4-inch section of the shield. The 1852, condenser C_2 , and coil L_2 are mounted in front of the parti-

shielded to prevent stray pick-up between the converter and the receiver. By-pass condensers and resistors are closely grouped around the tube socket, assuring short leads. A trimmer

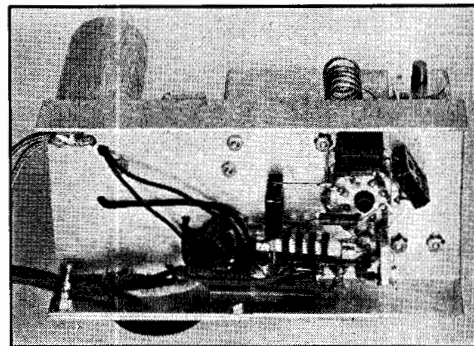

Fig. 2709 — Below-chassis wiring of the metal-tube converter. The 1852 socket may be seen at the right.

The Radio Amateur's Handbook

condenser, C_4 , soldered across L_3 , allows a small variable capacity to be used as the tuning element and at the same time makes the circuit fairly high- C in the interests of good stability.

A small panel is used to mount a vernier dial for the oscillator condenser. Since the r.f. tuning is not critical and, indeed, is broad enough to cover a good portion of the band with one setting, a small knob gives sufficient control.

The output line may be connected to the antenna and ground terminals of the standard receiver used as an i.f. amplifier, or to the "doublet" terminals, if provided. The exact i.f. chosen is not particularly important, so long as it is in the vicinity of 10 Mc. Choose a frequency which is free from signals, if possible, so that there will be no unnecessary interference from this source.

Tuning of the converter is as follows: With the r.f. and oscillator condensers at about half capacity, the padder, C_4 , is adjusted until 56-Mc. stations of known frequency are heard. After this the padder may be set to bring the high-frequency end of the band near minimum capacity on C_3 . The i.f. transformer should then be tuned for maximum signal strength. The 56-60-Mc. band will occupy approximately 60 to 70 divisions on the dial. The r.f. and mixer input circuits, L_1C_1 and L_2C_2 , may be made to track by squeezing or spreading the turns of L_1 and L_2 until both cover the same frequency range, as determined by loosening C_1 from the coupling and turning it independently to see if it peaks the noise at the same setting as C_2 .

Any type of antenna may be used, so long as it loads the r.f. grid circuit quite heavily. Optimum operation will result under these conditions. A single-wire antenna may be capacity-coupled, while a two-wire feeder system preferably should be inductively cou-

pled. The coupling coil should be slightly smaller than the r.f. coil, L_1 .

A 28- and 56-Mc. Converter for Mobile Use

Although 28-Mc. mobile work is prohibited at the time of writing, 56-Mc. work is not, and there is nothing to prevent the u.h.f. operator from carrying a receiver in his car capable of receiving on either band, since a check on 28-Mc. conditions often indicates when 56-Mc. is "hot." Obviously a most economical method of obtaining high sensitivity and selectivity is to employ a converter working into a car broadcast set. The plate power to operate the converter can be taken from the car radio set, while the car battery furnishes the filament power.

Figs. 2710-2713 show a single-tube converter which gives highly satisfactory performance in mobile operation. The i.f. output frequency is 1500 kc., to work into a standard-range b.c. receiver.

The size of the unit allows easy mounting on either dash or steering post.

The circuit, shown in Fig. 2711, uses a 6K8 triode-hexode converter tube in an arrangement which is not entirely conventional. A Colpitts type oscillator is used, having the advantage that it permits grounding the rotor of the tuning condenser, thus simplifying the insulation problem and eliminating hand capacity; furthermore, the oscillator coil need not be tapped, nor is an extra tickler coil required. The Hazeltine method of coupling the grid circuit to the antenna is used, the antenna coil (identical to the oscillator coil) being fed from the antenna at the low-impedance point, thus decreasing the possibility of trouble caused by antenna loading with the coupling coils commonly used. High gain can be achieved by the use of a tuned antenna, a quarter-wave rod (length adjusted to the band in use) on the rear bumper of the car, worked against the car as a ground. It can be coupled to the converter through a low impedance (36-ohm) cable.

An important feature of the circuit is the use of two midget neon bulbs in series as voltage regulators for the oscillator. Because the voltage drop across them is constant, variation in "B" voltage is negligible over a wide range of input-voltage change due to generator fluctuation. This eliminates frequency change in the oscillator. The neon bulbs are G.E. type T-2, without resistor.

The box is 3 by 4 by 5 inches, with the 4 by 5 sides removable. The tuning control is on

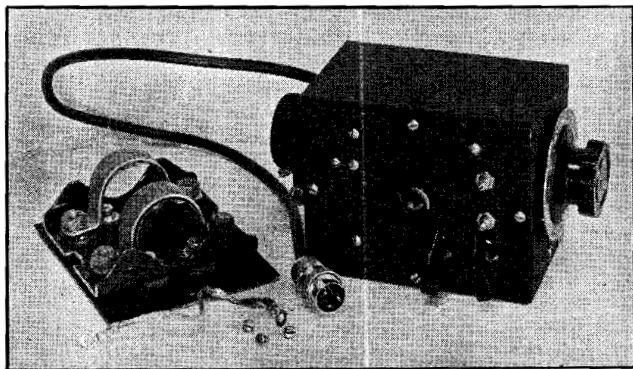

Fig. 2710 — This compact converter unit works on both 28 and 56 Mc. with any car broadcast receiver. The steering-column mounting, fastened to one side of the case, can be constructed from metal strip.

U.H.F. Receiving Equipment

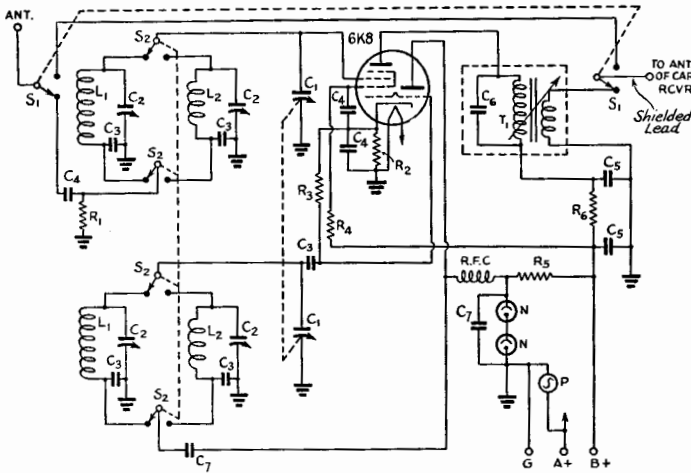

Fig. 2711 — Circuit diagram of the 28-56-Mc. mobile converter.

- C₁ — 5-15- μ fd. variable; ganged units (Sickles Type R trimmers).
- C₂ — 30- μ fd. trimmers (air type for oscillator coils, mica compression type for antenna coils).
- C₃ — 100- μ fd. midget mica.
- C₄ — 0.01- μ fd. paper (small size).
- C₅ — 0.1- μ fd. paper.
- C₆ — 30- μ fd. low-drift mica (in i.f. unit).
- C₇ — 0.002- μ fd. midget mica.
- R₁ — 0.1 megohm, $\frac{1}{2}$ -watt.
- R₂ — 300 ohms, $\frac{1}{2}$ -watt.
- R₃ — 50,000 ohms, $\frac{1}{2}$ -watt.
- R₄ — 30,000 ohms, $\frac{1}{2}$ -watt.
- R₅ — 25,000 ohms, 1-watt.
- R₆ — 1000 ohms, $\frac{1}{2}$ -watt.
- L₁ — 10 turns No. 18 tinned copper, diameter $\frac{1}{2}$ inch, length $\frac{3}{4}$ inch.
- L₂ — 4 turns No. 18 tinned copper, diameter $\frac{1}{2}$ inch, length $\frac{3}{4}$ inch.
- T₁ — 1500-ke. i.f. transformer with 15-turn output coil wound close to primary.
- N — Midget neon lamps.
- P — Pilot light.
- RFC — 5-meter choke (Sickles).
- S₁ — D.p.d.t. toggle switch.
- S₂ — 4-pole double-throw wafer switch (Yaxley 3100).

can be fitted in this space, with care in layout, if the constructor prefers not to make small aluminum containers to house them on the outside of the case.

The chassis is laid out to utilize the space to the greatest advantage by locating the parts to obtain the shortest connections. The tuning condensers, coils, socket and other parts are mounted to the sub-chassis, then this assembly is mounted to the side panel and is ready for wiring. Wiring from the oscillator and antenna trimmers, and from the band-switch to the 5- and 10-meter coils, will pass under the tube, but because the wiring is done more easily with the tube out of the socket it is well to remember this and allow for extra length in the leads. Grounds in the oscillator section are made at the socket, when possible, and in the antenna section at a central point at the control-shaft end of the

one 3 by 4 side. The chassis, with band-switch, oscillator, and antenna trimmers, is mounted on one of the 4 by 5 sides. To the other side is attached the fixture used to mount the unit to the steering post or instrument panel. The other 3 by 4 side is utilized for the i.f. transformer, the power cable, the antenna input and output, and the double-pole double-throw switch for cutting out the converter to permit broadcast reception on the car radio.

The chassis is of $\frac{1}{16}$ -inch aluminum, $2\frac{7}{8}$ by 4 inches, with side lips bent as shown in the photographs. A $2\frac{3}{4}$ by 3-inch aluminum plate is mounted vertically an inch from one end; and an L-shaped bracket is fastened to the chassis and plate as shown in one view. This assembly is attached to the side panel so as to clear the box flanges, and as near the front as possible. This will provide room between the chassis and the rear of the box for all necessary wiring to the socket, power cable, neon tubes, and other parts. The i.f. transformer and antenna switch

ganged condenser.

The i.f. transformer could be solenoid-wound, but a 1500-ke. unit can be purchased for a nominal sum and will be considerably more compact.

A three-prong shielded plug and socket (Amphenol) are used to pick up power from

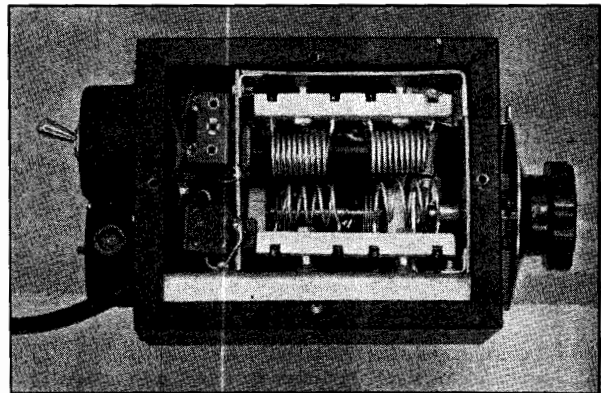

Fig. 2712 — A glimpse inside the case of the mobile converter, from the mounting side. The two coil sets are mounted inside an L-shaped bracket. The tuning condensers are visible behind the coils.

U.H.F. Receiving Equipment

be operated in the oscillating condition for the reception of c.w. signals, or just below oscillation for 'phone reception of weak signals when maximum amplification is needed.

The receiver is constructed on a chassis measuring $8\frac{1}{2}$ inches deep by 12 inches long by 2 inches high. Sufficient depth for ganging r.f., detector and oscillator condensers without cramping the components is provided. Adequate separation between these stages eliminates any possibility of undesirable coupling or interaction.

The most important details of construction pertain to the assembly and wiring of the high-frequency stages. Parts are arranged to permit extremely short r.f. leads and direct by-passing of all r.f. circuits. This is accomplished by mounting the acorn sockets on vertical aluminum partitions. At the front of the chassis, at the right-hand end, are the oscillator stage and its component parts. The 955 tube is mounted on a vertical partition $2\frac{3}{4}$ inches high by $2\frac{1}{4}$ inches wide. The socket is arranged with the cathode terminal facing towards the upper right corner of the partition, making a short and direct lead for the tap on the coil, and placing the grid terminal in a position which will allow a short and direct connection to the grid end of the oscillator coil through the 100- μ fd. grid condenser. The midget air oscillator

padding condenser and oscillator coil are mounted directly on the oscillator tuning condenser.

Directly behind the oscillator stage is the first detector. This complete assembly is made up on a 4-inch wide by $2\frac{3}{4}$ -inch high aluminum partition. The 954 acorn tube is mounted to the left of the tuning condenser with its plate terminal protruding through a $\frac{1}{4}$ -inch hole for short direct connection to the coupling condenser from the plate of the r.f. stage. This aluminum partition, in addition to offering support for all the component parts of the detector stage, also provides adequate shielding between stages. In the case of the r.f. stage, only the tuning condenser is mounted on the aluminum upright. This upright is $2\frac{3}{4}$ inches high by $2\frac{1}{4}$ inches wide, and likewise shields the r.f. coil and tuning condenser from the detector stage. The 1851 tube is mounted directly to the left of this assembly, making a short grid lead to the coil.

Initial adjustments, after construction is completed, are made as follows: The i.f. transformers are adjusted to 1600 kc. Then with tuning condensers set at half capacity, the oscillator padding condenser is adjusted until a signal of approximately 58 Mc. is heard. A test oscillator is helpful, although a signal from the transmitter can be used, or perhaps some local

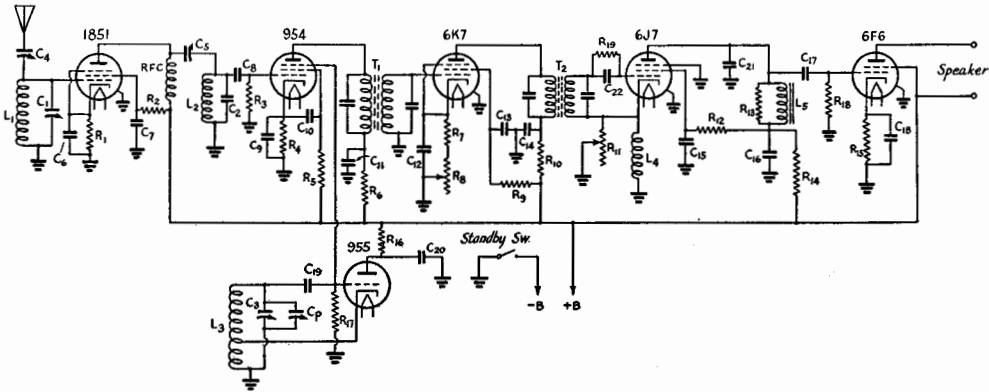

Fig. 2715 — 56-Mc. superhet circuit diagram.

- | | | |
|---|---|---|
| C ₁ , C ₂ — 10- μ fd. (Cardwell ZR-10-AS). | C ₂₁ — 0.002- μ fd., 400-volt tubular. | L ₁ — 8 turns No. 14, $\frac{1}{2}$ " diameter, winding length $1\frac{1}{2}$ ". |
| C ₃ — 15- μ fd. (Cardwell ZR-15-AS). | R ₁ — 150 ohms, $\frac{1}{2}$ -watt. | L ₂ — 9 turns No. 14, $\frac{1}{2}$ " diameter, winding length $1\frac{1}{2}$ ". |
| C ₄ , C ₅ — 3-35- μ fd. (Isolantite) padders. | R ₂ — 60,000 ohms, $\frac{1}{2}$ -watt. | L ₃ — 4 turns No. 14, $\frac{1}{2}$ " diameter, winding length $\frac{1}{2}$ " (cathode tap $\frac{1}{2}$ turn from ground end). |
| C _p — 50- μ fd. air padder (Hammarlund APC-50). | R ₃ — 1 meg., $\frac{1}{2}$ -watt. | L ₄ — 30 turns No. 24, closewound on $\frac{1}{2}$ " form. |
| C ₆ , C ₇ , C ₈ , C ₁₀ — 0.01- μ fd., 400-volt tubular. | R ₄ , R ₁₀ — 2000 ohms, $\frac{1}{2}$ -watt. | L ₅ — 1080-henry plate impedance (Thoradson T-29C27). |
| C ₈ , C ₁₃ , C ₁₅ , C ₁₆ — 0.1- μ fd., 400-volt tubular. | R ₅ , R ₁₂ , R ₁₆ — 100,000 ohms, $\frac{1}{2}$ -watt. | RFC — 2 $\frac{1}{2}$ -mh. r.f. choke (National R100). |
| C ₁₁ , C ₁₄ — 0.05- μ fd., 400-volt tubular. | R ₆ — 2000 ohms, $\frac{1}{2}$ -watt. | T ₁ — 1600-kc. iron core i.f. (Meissner No. 16-8091). |
| C ₁₂ , C ₁₃ , C ₁₅ , C ₁₆ — 0.1- μ fd., 400-volt tubular. | R ₇ — 300 ohms, $\frac{1}{2}$ -watt. | T ₂ — 1600-kc. iron core i.f. (Meissner No. 16-8099). |
| C ₁₇ — 0.02- μ fd., 400-volt tubular. | R ₈ — 50,000-ohm potentiometer. | |
| C ₁₈ — 10- μ fd., 25-volt tubular. | R ₉ , R ₁₇ — 50,000 ohms, $\frac{1}{2}$ -watt. | |
| C ₂₀ — 0.001- μ fd. midget mica. | R ₁₁ — 1000-ohm potentiometer. | |
| | R ₁₃ — 250,000 ohms, $\frac{1}{2}$ -watt. | |
| | R ₁₄ — 25,000 ohms, $\frac{1}{2}$ -watt. | |
| | R ₁₅ — 450 ohms, 10-watt. | |
| | R ₁₈ — 500,000 ohms, $\frac{1}{2}$ -watt. | |
| | R ₁₉ — 5 meg., $\frac{1}{2}$ -watt. | |

The Radio Amateur's Handbook

58-Mc. signal can be heard. If coils are made in accordance with specifications, the oscillator padding condenser will fall at a point slightly less than half meshed. The r.f. coupling condenser is then adjusted and the r.f. and detector coils pruned for maximum signal strength. The coils are pruned by compressing or expanding turns slightly, and when adjusted for the middle of the band will track sufficiently well over the entire band. The antenna trimmer condenser is also adjusted for best sensitivity with the particular antenna with which the set is used.

Any well-filtered power supply delivering approximately 250 volts at 70 ma. will be satisfactory. (*Bib. 3.*)

● SUPERREGENERATIVE RECEIVERS

As mentioned before, superregenerative receivers are widely used on the u.h.f. bands that do not have rigid stability requirements and where the need for selectivity is not too great. They are capable of excellent performance and, when properly adjusted, have decided noise-discriminating properties and a.v.c. action.

The superregenerative receiver is tuned in a similar manner to the regular regenerative receiver when used on 'phone. The regeneration control is advanced until a hiss is heard and the signal can then be tuned in. It will be found that the hiss will disappear to a greater or lesser degree, depending upon the strength of the signal. The most sensitive condition for the superregenerative receiver is at the point where the hiss first becomes marked — the receiver will not be in its most sensitive condition with the hiss going full blast.

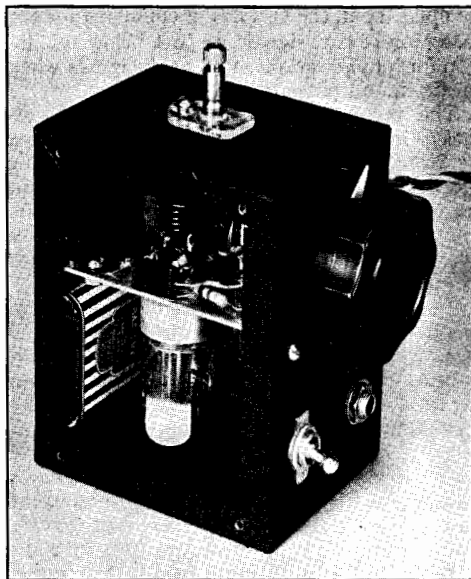

Fig. 2717 — A 112-Mc. receiver using 1.4-volt tubes, mounted in a 5- by 4- by 3-inch can. The tuning knob, phone jack and battery switch are seen on the front panel — the binding post on top takes the antenna. Note the C battery mounted in the can.

If the receiver does not hiss evenly over the entire band, it indicates that insufficient feedback is present or that the antenna is coupled too tightly. The tuning range of the receiver is adjusted as in the case of the regenerative receiver, by adjusting the inductance until the center of the band comes at the center of the tuning range. If not enough bandspread is obtained, a smaller tuning condenser should be used.

No trouble should be encountered in adjusting a superregenerative receiver using a separate quench oscillator, providing the quench oscillator oscillates and the detector can also be made to oscillate. The self-squegging type of superregenerative detector will require some critical adjustment of grid-leak value and feedback before it is operating smoothly. If trouble is experienced with making the detector oscillate, the wiring should be checked to assure that no long leads are present which introduce too much reactance into the circuits at the wrong points. On the ultra-high frequencies, a short length of wire can have appreciable inductance and

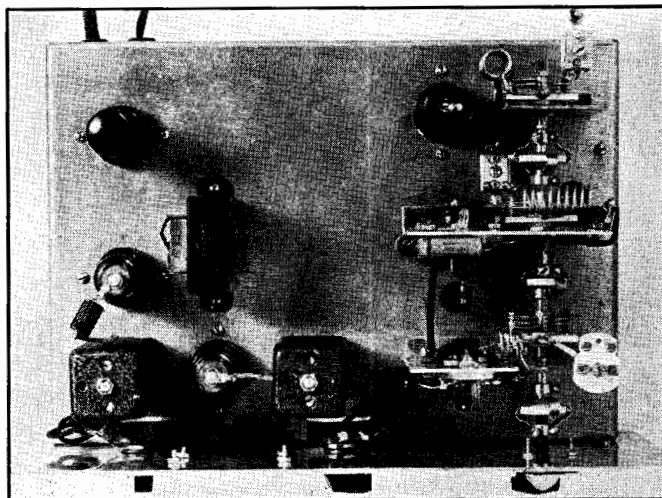

Fig. 2716 — Plan view of the 56-Mc. superhet. The r.f. section, at right, is separated from the i.f. amplifier, second detector and audio amplifier. The acorn mixer and oscillator tubes are mounted on aluminum partitions.

U.H.F. Receiving Equipment

may act as a choke coil. Ground returns through by-pass condensers should be kept short and preferably should be brought to one point on the chassis.

A Compact 112-Mc. Receiver

The receiver shown in Figs. 2717, 2719 and 2720 is a small self-quenched unit designed primarily for portable work, although it will perform as well as any other similar receiver in home operation. It uses the 1.4-volt loktal tubes, a 1LE3 detector and a 1LA4 audio amplifier. A 3 by 4 by 5-inch metal box (Par-metal MC-453) is used to house the receiver, and the tube sockets, tuning condenser and audio transformer are mounted on a 3 by 4-inch sub-chassis mounted in

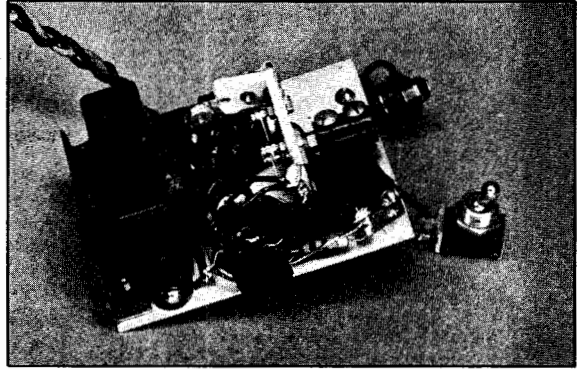

Fig. 2719 — A close-up view of the chassis removed from the box. Note that one mounting bracket (in back of the transformer) is mounted above the chassis, while the front bracket is mounted below. A nut soldered to the antenna coupling condenser makes connection to the antenna post wire a simple matter after assembly.

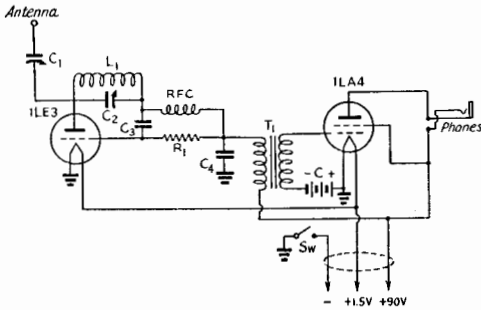

Fig. 2718 — Circuit diagram of the 112-Mc. battery receiver.

- C₁ — 3-15- μ fd. mica compression trimmer (National M-30 with top plate trimmed).
- C₂ — 5- μ fd. midget variable (National UM-15 with two rotor and two stator plates removed).
- C₃ — 50- μ fd. mica.
- C₄ — 0.001- μ fd. mica and 500- μ fd. mica in parallel. See text.
- T₁ — Audio coupling transformer (Thordarson T13A34).
- R₁ — 5 megohms, $\frac{1}{2}$ -watt.
- Sw — S.p.s.t. toggle.
- C — 4 $\frac{1}{2}$ -volt C battery (Burgess A3BPX).
- L₁ — 5 turns No. 14 enam. $\frac{1}{2}$ -inch diam. and spaced to occupy $\frac{1}{2}$ -inch winding length.
- RFC — 20 turns No. 24 enam. closewound, $\frac{1}{8}$ -inch diam. or Ohmite Z-1.

the box by two strips of $\frac{1}{2}$ -inch angle brass. It will be noted from Figs. 2719 and 2720 that the brackets are mounted on opposite faces of the sub-chassis. This allows the sub-chassis to be placed inside the box and rotated into place, a maneuver that would be impossible if both brackets were mounted on the same side.

A low-loss bakelite socket is used for the detector tube and an ordinary bakelite loktal socket is used for the audio amplifier. Both sockets are ring-mounting (Amphenol). The mounting of the tuning condenser is a bit unconventional in that a slot is cut in the sub-chassis that will just pass the Isolantite end

plate of the tuning condenser, and the bracket that mounts the condenser is mounted on the opposite side of the sub-chassis from the tuning condenser proper. This is the only way this tuning condenser and combination of tubes can be placed in the small space. The inductance, L₁, is soldered directly to the terminals of the tuning condenser, as is the antenna coupling condenser, C₁. To facilitate connecting C₁ to the antenna post after the unit has been assembled in the box, a nut is soldered to the antenna side of C₁, thus permitting a lug from the antenna post to be fastened conveniently.

The A and B batteries are carried outside the receiver, but the C battery is mounted inside the box. It is held in place by a small brass bracket screwed to the box and holding the positive terminal of the battery.

Putting the receiver in operation is similar to any self-quenched superregenerative receiver. The receiver should first be checked

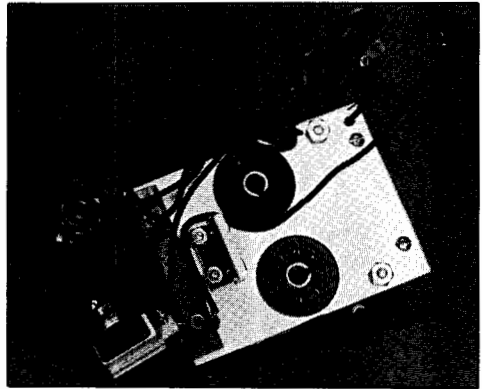

Fig. 2720 — A view of the other side of the chassis shows the position of the tube sockets and the mounting detail of the tuning condenser.

The Radio Amateur's Handbook

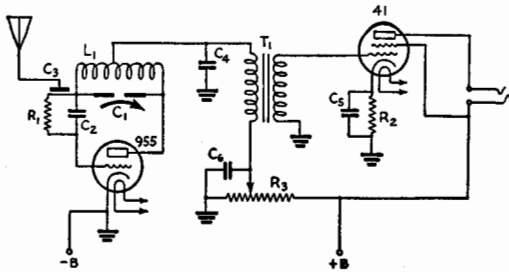

Fig. 2721 — Circuit of an "Acorn" receiver.

- L₁ — Five turns of No. 14 wire $\frac{1}{4}$ -inch inside diameter with turns spaced diameter of wire, for 224 Mc. Five similar turns $\frac{1}{2}$ -inch diameter for 112 Mc.
- C₁ — Cardwell Type ZR 15AS condenser — Special split-stator tuning condenser — two rotor and one stator plate — the latter sawed in two.
- C₂ — 50 μ fd. midget condenser.
- C₃ — Brass strip 3/16 inch wide mounted close to the exposed surface of C₂.
- C₄ — 0.002 μ fd. fixed condenser.
- C₅ — 10 μ fd. electrolytic condenser.
- C₆ — 1 μ fd.
- R₁ — 5 to 10 megohms.
- R₂ — 1200 ohm, one-watt resistor.
- R₃ — 100,000 ohm potentiometer. Note that this resistor is across plate supply and that, if batteries are used, the supply should therefore be disconnected when switching off set.

A 41 tube is used as the audio amplifier and allows speaker operation. A transformer or choke-condenser coupling unit must be used with this tube. For head-phone work, a 37 tube would be more appropriate. Quieter operation may sometimes be obtained by putting 0.5 megohm across the transformer secondary.

with the antenna disconnected and, if it doesn't squegg over the proper range, the values of R₁ and C₄ should be varied. It was found in this particular set that two condensers in parallel were needed at C₄ — a 0.001- μ fd. one that was grounded at the front of the sub-chassis and 500- μ fd. one that was grounded at a lug under one side of the audio transformer.

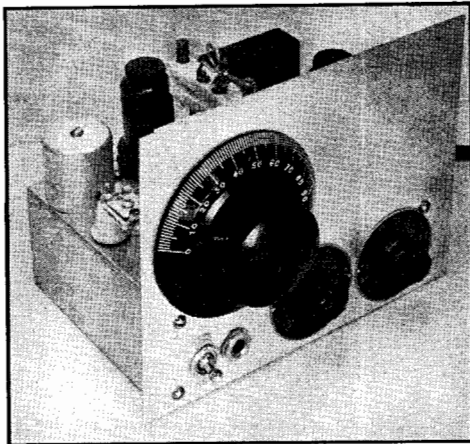

Fig. 2722 — A three-band plug-in coil separately quenched superregenerative receiver.

A few trial connections will indicate the best positions.

When the receiver is squegging properly, the antenna can be connected and the coupling condenser C₁ adjusted. It will probably be found that the maximum amount of antenna can only be used with the condenser set at the minimum capacity position. In any event, use as much antenna as is possible with smooth operation. The receiver should give a smooth hiss over the band and not a rough sound when working correctly.

The power needed is simply a 1½-volt dry cell and 90 volts of B battery. These batteries are carried externally and can be placed in a small box for convenience.

A Self-Quenched Acorn-Tube Receiver

In Fig. 2721 is a somewhat similar type of circuit except in the type of detector tube used.

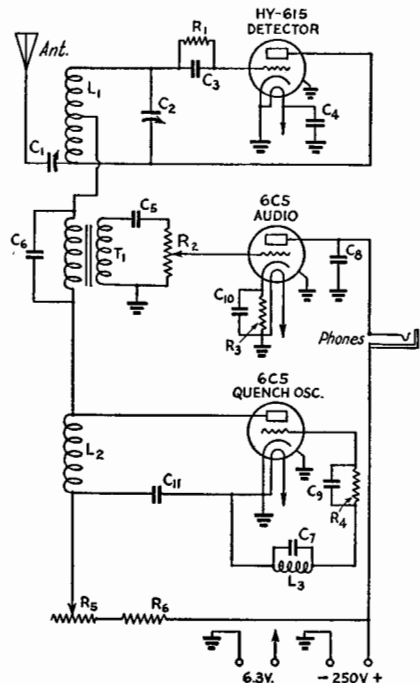

Fig. 2723 — Plug-in coil receiver circuit.

- C₁ — 30- μ fd. isolantite-insulated trimmer.
 - C₂ — 2-plate midget variable (National UM-15 with all but two plates removed).
 - C₃ — 100- μ fd. mica.
 - C₄, C₅ — 0.01- μ fd. paper.
 - C₆, C₇ — 0.002- μ fd. mica.
 - C₈, C₉ — 0.001- μ fd. mica.
 - C₁₀ — 0.5- μ fd. paper.
 - C₁₁ — 0.1- μ fd. paper.
 - R₁ — 5 megohms, $\frac{1}{2}$ -watt.
 - R₂ — 500,000-ohm variable.
 - R₃ — 2000 ohms, $\frac{1}{2}$ -watt.
 - R₄ — 50,000 ohms, $\frac{1}{2}$ -watt.
 - R₅ — 50,000-ohm variable.
 - R₆ — 10,000 ohms, 1-watt.
 - L₁ — 56 Mc.: 12 turns No. 14, length $1\frac{1}{8}$ inches, diameter $\frac{5}{8}$ inch.
 - 112 Mc.: 4 turns No. 14, length $\frac{3}{8}$ inch, diameter $\frac{5}{8}$ inch.
 - 224 Mc.: 1 turn No. 14, diameter $\frac{1}{2}$ inch.
- All diameters are outside; all coils tapped at center.

U.H.F. Receiving Equipment

In this case the acorn detector, because of its extremely small elements and short leads, allows operation on frequencies as high as 300 Mc. This receiver is therefore a particularly useful one in cases where experiment is to be conducted on the bands higher in frequency than 112 Mc. The circuit itself is quite similar to that of Fig. 2718 except in minor details. The grid resistor is again connected to the coil carrying high voltage but in some instances it is preferable to run it in the conventional manner between the grid and cathode. The other important difference in this circuit is that the tuning condenser is of the split-stator type. By splitting the stator plates of the small tuning condenser used, the path through the condenser is reduced in length and extremely short connections between the coil and condenser are made possible. The suggested sizes for coils for the two bands are, of course, approximate only. Slight variation of the length of the leads within the tuned circuit will result in modification of the coils. Fortunately, small variations of the inductance can be made readily by spacing the turns until the desired tuning range is obtained.

A Three-Band Superregenerative Receiver with Separate Quench Tube

As the circuit (Fig. 2723) shows, the receiver employs three tubes. A Type HY-615 high-frequency triode is used as the detector, and 6C5 triodes are found in both the quench and audio stages. The set may be considered to be a "general purpose" unit, since it may be operated from battery power, as well as the usual

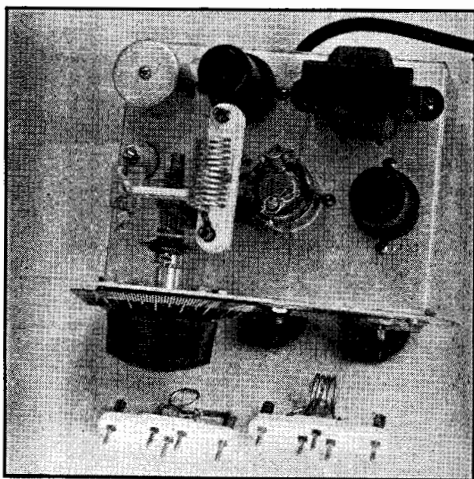

Fig. 2724 — Top view of the plug-in coil receiver with a 56-Mc. coil in place. Notice the closely grouped components of the detector circuit. The quench coil is at the left rear corner with the quench tube just to the right.

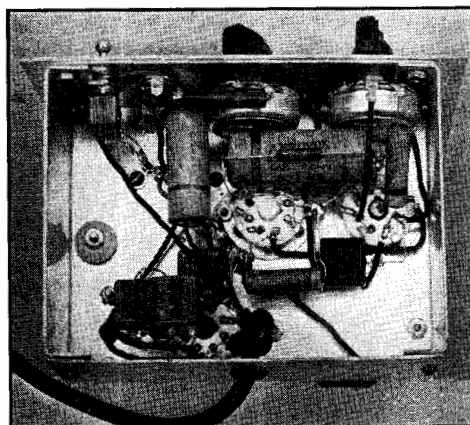

Fig. 2725 — Bottom view of the plug-in coil receiver. Parts are arranged for the prime purpose of obtaining short ground connections.

power pack, is compact and portable, and the plug-in coils permit instantaneous operation on any of the two ultra-high-frequency bands.

The top view, Fig. 2724, shows the compactness of the detector circuit layout. This portion of the circuit is arranged as shown on the 6 by 4½ by 2-inch aluminum base. The parts line-up across the panel side of the chassis is as follows: At the left, supported by a small stand-off insulator, is the antenna coupling condenser, C₁. To the right of C₁ is the detector circuit consisting of the tuning condenser, C₂, the plug-in-coil assembly and the detector tube. The audio tube is at the right. Across the back from right to left are the quench-coil unit, the quench tube and the audio transformer.

The coil-socket is mounted on pillars between the condenser and the tube, high enough so that its prongs are in line with the tube caps and the condenser lugs. Of the three prongs forming a small triangle at the center of the socket, the two along the side face the condenser and the single prong faces the tube. The single prong is the terminal to which the quench lead and coil tap are connected. A fourth prong, located at the panel end of the form, is connected to the grid side of C₂. The antenna-coupling condenser is connected to this point.

The opposite view, Fig. 2725, shows the placement of the by-pass condensers, resistors, switch and headphone jack, and the potentiometers. By-passing must be as direct as possible and preferably to not more than one or two points. The plate and filament voltage cable enters the chassis through a hole in the rear wall.

In the panel view, Fig. 2722, the tuning dial is at the left with the jack and switch just below. The small dial at the bottom right edge

The Radio Amateur's Handbook

is on the volume control and the adjacent one on the regeneration control. The panel measures $5\frac{1}{2}$ by 7 inches.

Construction of the coils is quite simple, as indicated by Fig. 2724. Each is soldered directly to the appropriate lugs on the form. The position of the tap is not particularly critical; tapping at approximately the center of the coil should be sufficient. Each coil covers slightly more than the intended band, with the band itself spread over approximately 75 divisions of the dial. Data on a 56-Mc. coil is also included.

The total current drain of the receiver is 18 milliamperes, 5 ma. each for the detector and quench tubes and 8 for the audio stage.

The antenna loading is not too critical; almost any length of wire can be coupled to the detector, through C_1 , without overloading the circuit. Of course the capacity of C_1 must be varied to suit the particular band.

Superregenerative Receivers with R.F. Amplifiers

One important disadvantage of the simple superregenerative receivers just described is that they are capable of strong radiation. Also, as we have already stated, they are extremely unselective. Prevention of radiation and some improvement in selectivity is made possible by adding an r.f. amplifier stage ahead of the superregenerative detector. Fig. 2726 illustrates various methods of coupling the r.f. stage to the detector. All of them have been shown to be effective in practice but each has its particular points of merit. The circuit shown at "A" will be recognized as an example of conventional transformer coupling with normal wiring of the r.f. amplifier itself. The best number of turns for L_3 will usually be just

slightly less than that used in L_4 , but this depends upon the order of coupling between the two coils and the order of freedom with which the detector superregenerates. One of the difficulties in this arrangement is in providing a suitable mechanical arrangement for mounting the coils. L_4 may be wound on a form of some good insulating material with the turns of L_3 occupying the spaces between the turns of L_4 but many workers prefer to avoid any dielectric in the field of u.h.f. coils. Then, L_3 may be wound on a slightly smaller form pushed inside the turns of L_4 . One effective alternative scheme is to make L_3 of about 30 gauge d.s.c. wire with the turns cemented to the turns of L_4 with Duco cement or its equivalent. Yet another method is to make L_3 a self-supporting coil of No. 18 wire of a diameter just sufficient to slide inside L_4 . In this case, L_3 might well be mounted from small stand-off insulators.

The arrangement shown at "B" in Fig. 2726 is particularly suitable in receivers having the high voltage applied to the detector coil as in Figs. 2721 and 2723. The plate lead is merely tapped near the grid end of the detector coil with no other modification to the detector circuit.

Circuit "C" in the same illustration is a general-purpose affair suited for almost any receiver. In this arrangement the plate voltage is applied to the r.f. tube plate through a good u.h.f. choke, a coupling condenser of 5 to 15 μfd . then being connected between the r.f. plate and the grid end of the detector coil. Coupling is varied by changing the capacity of C .

In all of the circuits the most important adjustment is the order of coupling between the r.f. tube and the detector. The superregenerative detector is extremely sensitive to changes of the load on its grid circuit and usually operates most effectively when heavily loaded. On the other hand, tight coupling and the conse-

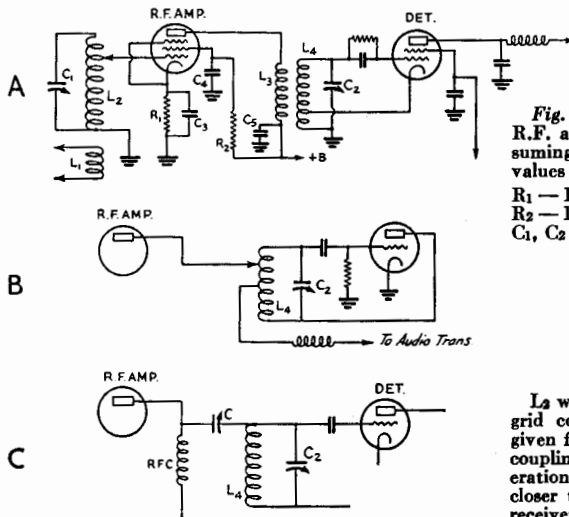

Fig. 2726 — Three effective methods of coupling an R.F. amplifier to the superregenerative detector. Assuming that the r.f. amplifier is a 954 acorn, suitable values for the various components marked will be:

- R_1 — 1500-ohm half-watt.
- R_2 — 100,000-ohm half-watt.
- C_1, C_2 — 15 μfd . Some difficulty may be had in making the two condensers "track" if a conventional tube is used as a detector. If single dial operation is essential, C_1 may be loaded with a 15- μfd . trimmer in parallel to provide the equivalent of the higher tube capacity across L_4 . A separate control for C_1 or a parallel trimmer condenser available for control from the front panel is very desirable.

L_3 will be exactly similar to L_4 — the usual detector grid coil. L_1 should comply with the specifications given for the usual antenna coil. Since variation of its coupling will have relatively little effect on the regeneration in the detector it may usually be operated closer to the grid coil than would be possible in the receiver lacking an r.f. stage.

U.H.F. Receiving Equipment

quent heavy loading of the detector will not allow the maximum possible r.f. selectivity. The coupling adjustment should therefore be varied to give the desired optimum performance considering both selectivity and sensitivity.

Suitable Tubes for R.F. Amplifiers

The types 954 and 956 acorn pentodes are, without the slightest doubt, the most effective r.f. amplifiers for 112 Mc. and above. They are, indeed, so far superior to the conventional glass or metal tubes that the serious u.h.f. worker is rarely inclined even to consider using anything else. Even on 56 Mc. the 954 and 956 are incomparably superior to the normal screen-grid pentode, although the special types 1852

and 1853 are quite effective at this frequency.

In general it will be found that quite simple shielding will serve to prevent oscillation, providing the by-passing has been done carefully. A simple baffle is probably the most practical arrangement for the acorn — the tube socket being mounted on the baffle or partition and the tube grid protruding through a small hole in the metal. The most satisfactory socket available for this type of amplifier is the National Type XMA metal socket. Excellent by-passing is possible with this particular design.

Bibliography

- ¹ Goodman, *QST*, March, 1940.
- ² Chapman, *QST*, June, 1939.
- ³ Wagenseller, *QST*, Feb., 1939.

Transmitters and Transceivers for the U.H.F.

Crystal-Controlled and Self-Excited Transmitters — Transceivers and Transmitter-Receivers for Portable/Mobile Work

ALTHOUGH most of the transmitters described in Chapter Ten can be used on the 28-Mc. band, the long leads and high minimum capacities of the tuning condensers make it desirable to design special equipment for the 56-Mc. band. Further, the excitation requirements for the same tubes are usually greater on 28 and 56 Mc., and exciter units designed for these ranges should be used. The general practice is, however, exactly the same, except that particular care must be taken in the layout of components (for short, direct leads) and in the selection of tubes. It is well to work with tubes designed for the higher frequencies.

This chapter will describe several different complete transmitters designed for the 28- and 56-Mc. range, varying in power output from a few watts (for mobile work) to several hundred. Higher-powered transmitters can be built using

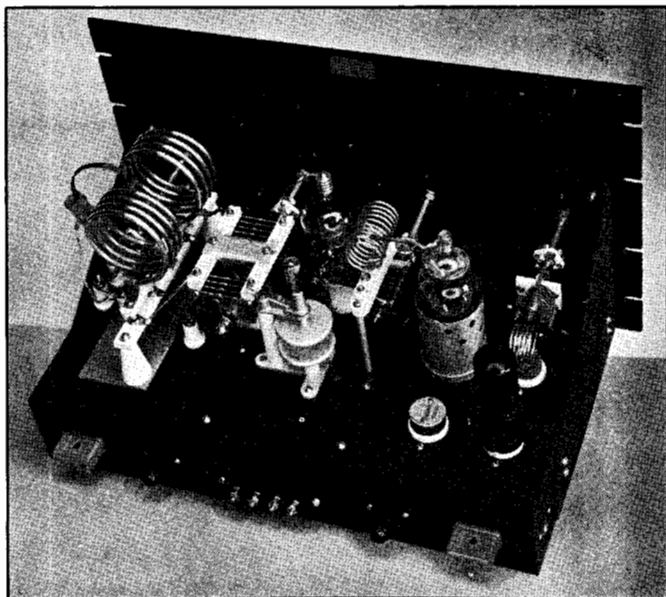

Fig. 2802 — The top view of the 28- and 56-Mc. exciter. The oscillator plate coil is supported by the base of a 1-inch coil form; the winding portion of the form has been cut away flush with the base.

one of these as the exciter unit to drive a higher-powered final amplifier built with the same design considerations.

These transmitters are designed primarily for amplitude modulation and c.w. — transmitters using f.m. for the 56- and 112-Mc. bands will be found in Chapter Twenty-Nine.

A Medium-Power Exciter for 10 and 5 Meters

The photographs of Figs. 2801, 2802 and 2804 show views of an exciter capable of delivering approximately 50 watts output. Referring to Fig. 2803,

Fig. 2801 — A panel view of the medium-power exciter. Dials for the 6L6, 807 and HK-54 plate tuning condensers and the swinging link run from left to right, respectively. The meter-switch knob is at the lower left edge of the panel, and the filament pilot light jack is on the same line and to the right. The panel measures 10½ by 19 inches.

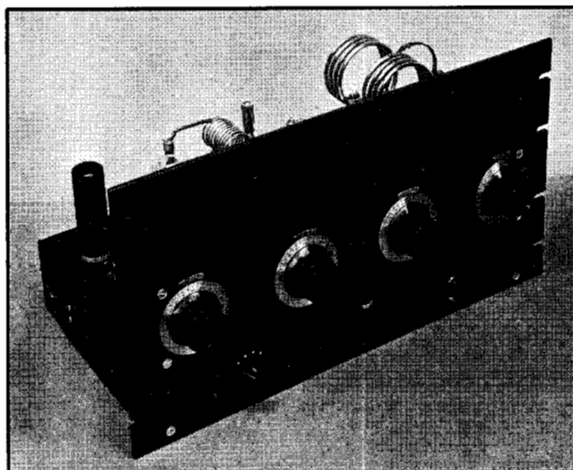

Transmitters and Transceivers for the U.H.F.

a 6L6 Tri-tet oscillator using a 7-Mc. crystal quadruples to 28 Mc. The 807 intermediate amplifier drives the HK-54 as a straight-through amplifier at 28 Mc. or as a doubler to 56 Mc.

Fig. 2801 shows the unit built on a 10 by 17 by 3-inch chassis. The plate tuning condensers are mounted above the base and the cathode tuning condenser is mounted on the chassis wall as may be seen in Fig. 2804. L_2 and L_3 are equipped with plug-in bases in order that operation with 14- and 28-Mc. crystals may be tried if desired. L_3 is supported above C_3 by a small bracket and a metal pillar; the bracket runs between the condenser shaft and the front end of the coil socket, and the pillar elevates the rear end of the socket. The 807 plate lead is connected two turns down from the hot end of the coil. This allows the plate lead to be short and helps to prevent the double-resonance effect frequently encountered with circuits employing beam-power tubes. The final amplifier tank circuit uses a swinging-link assembly for output coupling. Input and output termi-

nals are mounted on the rear wall of the chassis. The jacks at the right and left ends are for the input and output connections; an input jack was included so that the output of a frequency-modulator unit can be fed into the Tri-tet oscillator if desired. Two terminals are provided for the positive plate-voltage leads and the bias, key and negative-voltage leads are brought to a four-terminal connector strip.

Fig. 2804 shows a meter switch installed so that plate and grid current readings can be made with the same meter. The HK-54 plate circuit is not included in this arrangement because the amount of power supplied to this stage makes it desirable that a separate meter be used. The filament transformers may be seen at the rear of the chassis and the cathode coil, L_1 , is shown mounted on the cathode condenser lugs. A jack for the filament pilot bulb is fastened to the front wall of the chassis.

A 600-volt power supply delivering 200-ma. should be used for the 6L6 and 807 stages and a 1000-volt 200-ma. supply is needed for the

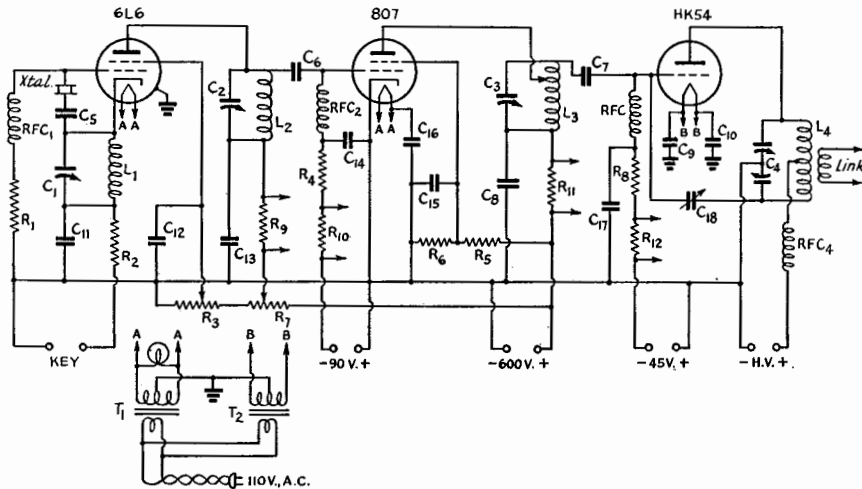

Fig. 2803 — Wiring diagram of the 6L6-807-HK-54 exciter.

- | | | |
|--|---|--|
| C_1 — 35-120- μ fd. padder condenser (Meissner 22-7027). | C_9, C_{10} — 0.002- μ fd. mica. | R_8 — 25,000 ohms, 25-watt. |
| C_2 — 35- μ fd. midget variable (Cardwell ZR-35-AS). | $C_{11}-C_{17}$ — 0.01- μ fd., 600-volt paper. | $R_9, R_{10}, R_{11}, R_{12}$ — 25 ohms, $\frac{1}{2}$ -watt. |
| C_3 — 30- μ fd. midget variable (Cardwell ZT-30-AS). | C_{18} — Neutralizing condensers (National NC-800). | R.F.C.1 — R.f. choke, 2.5 mh. (National R-100). |
| C_4 — 35- μ fd. each section dual transmitting condenser (Millen 13035). | R_1 — 20,000 ohms, 1-watt. | T_1 — 6.3 V., 2 Amps. (Thordarson T-19F81). |
| C_5, C_6, C_7 — 0.0005- μ fd. mica. | R_2 — 200 ohms, 1-watt. | T_2 — 5 V., 5 Amps. (Thordarson T-19F83). |
| C_8 — 0.002- μ fd., 2500-volt mica. | R_3 — 25,000 ohms, 50-watt. | R.F.C.2 — R.F.C. 4 — U.h.f. r.f. chokes (Ohmite Z-1). |
| L_1 — 11 turns No. 18 enam. spaced to occupy 1-inch length, $\frac{3}{4}$ -inch diam. | R_4 — 25,000 ohms, 1-watt. | each side c.t. with turns separated $\frac{1}{2}$ -inch, 2-inch diameter. $1\frac{1}{2}$ -inch space between windings. |
| L_2 — 5 turns No. 14 spaced to occupy $\frac{1}{2}$ -inch length, 1-inch diameter. | R_5 — 20,000 ohms, 10-watt. | |
| * L_3 — 10 turns No. 12 spaced to occupy $1\frac{3}{4}$ -inch length, 1-inch diameter. | R_6 — 30,000 ohms, 10-watt. | |
| † L_4 — 28 Mc.: 8 turns of $\frac{3}{8}$ -inch copper tube; 4 turns each side c.t. with turns separated diam. of tubing, $2\frac{1}{2}$ -inch diameter. $1\frac{1}{2}$ -inch space between windings for swinging link injection. | R_7 — 3,000 ohms, 25-watt. | |
| 56 Mc.: 4 turns of $\frac{3}{8}$ -inch copper tube. 2 turns | | |

* Mounted on Millen No. 40205 midget plug; plug uses No. 41205 socket.

† Mounted on Barker and Williamson TV base assembly. The assembly is complete with the swinging link and a socket for the coils. Coils use B & W T plug bar No. A62.

Output link consists of three turns No. 14 enam., turns separated diam. wire, $2\frac{1}{2}$ -inch diam.

The Radio Amateur's Handbook

Fig. 2804 — A bottom view of the 6L6-807-HK-54 exciter. The inductance of the cathode coil, shown at the right, plays an important part in the oscillator performance. The coil should be carefully pruned for low-crystal current and satisfactory plate circuit output. Crystal current may be checked with the aid of the 60 ma. pilot bulb shown connected in series with the crystal; proper plate circuit output will be indicated by suitable readings of the 807 grid current. The a.c. line cord for the filament transformer runs straight out of the top of the chassis.

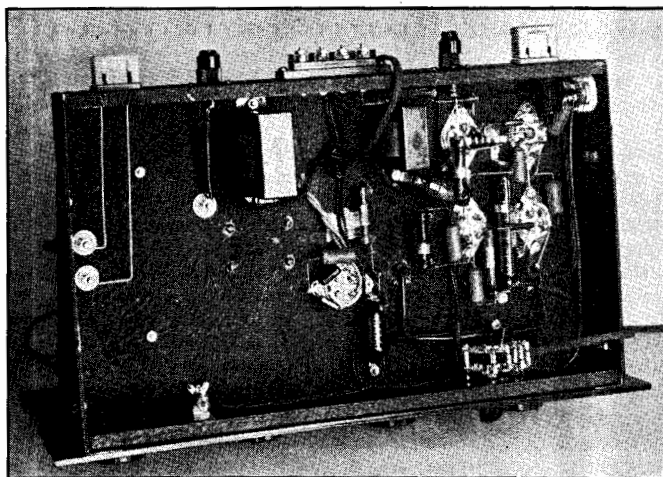

HK-54. The 807 requires 90 volts of fixed bias to insure that trouble with oscillation will not occur. The final should have 45 volts of fixed grid bias applied to prevent damage to the tube should excitation fail. Resistors R_3 and R_7 should be adjusted to reduce the 600-volt supply output to values suitable for the 6L6 screen grid and plate; the screen grid requires 200 volts, and 400 volts should be applied to the plate. When operated under these conditions the oscillator will draw between 90 and 100 ma. plate current, the 807 grid current will be 1 to 1.5 ma., and the plate will draw from 50 to 60 ma. The grid current to the HK-54 will be 20 to 25 ma., and the plate current can be as high as 100 ma., loaded. Approximately 50 watts output may be expected at 56 Mc., and slightly more on 28 Mc.

A power amplifier or low-impedance antenna feed line may be connected directly to the swinging link output terminals. The unit should be link coupled to an antenna tuner if the antenna uses tuned feeders or a high-impedance flat line.

A Medium-Power Push-Pull Amplifier

The push-pull amplifier shown in Figs. 2805, 2807 and 2808 can be plate modulated at both 28 and 56 Mc. The d.c. plate input can be as high as 300 watts (roughly 1250 volts at 250 ma.) at 28 Mc., and 200 watts at 56 Mc. (1000 volts at 200 ma.). During periods of c.w. operation it is permissible to run the tubes up to the full ICAS

Fig. 2805 — A front view of the medium-power push-pull amplifier. The large dials at the center and right are mounted on the plate tuning condenser and swinging-link shafts. The filament pilot light is at the left with the grid-condenser knob below.

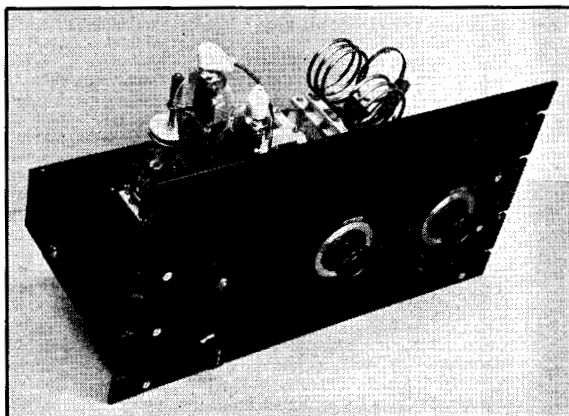

rating of 450 watts. It is intended that the amplifier will be driven by an exciter similar to the one shown in Figs. 2801-2804.

The circuit diagram of the amplifier is given in Fig. 2806. It is recognized as a standard arrangement with the exception of two features; the rotor plates of the plate tuning condenser are not grounded and the usual plate circuit r.f. choke is omitted. It was found that grounding of the rotor plates presented no particular advantage as far as circuit balance or efficiency was concerned. However, the absence of a ground connection does remove the voltage potential across the condenser plates and it is therefore possible to use a condenser with smaller spacing between plates than ordinarily required. The r.f. choke was omitted because it tended to encourage parasitic oscillations.

Fig. 2807 shows how the parts are laid out on a 10- by 17- by 3-inch chassis. The grid coil is visible at the right end of the chassis and the plate coil is to the extreme left. In between, the tubes and the plate and neutralizing con-

Transmitters and Transceivers for the U.H.F.

Fig. 2806 — Circuit diagram of the medium-power push-pull amplifier.

- C₁ — 100- μ fd. each section dual (Hammarlund HFBD-100-C).
- C₂ — 35- μ fd. each section dual transmitting condenser (Millen 13035).
- C₃, C₄ — Neutralizing condensers (National NC-800).
- C₅, C₆ — 0.005- μ fd. midget mica.
- R₁ — 1500 ohms, 10-watt.
- T₁ — 6.3 volts, 10-amp. (Thordarson T-19F99).
- L₁ — 28 Mc: 4 turns No. 12, 1 $\frac{1}{4}$ -inch long, 2-inch diam. (Barker and Williamson 10BL with 4 turns removed).
56 Mc: 2 turns No. 12, $\frac{1}{4}$ -inch long, 1-inch diam. (Mounted on Barker and Williamson B-Plug Bar No. A64).
- L₂ — 28 Mc: 6 turns $\frac{3}{8}$ -inch copper tubing; 3 $\frac{3}{4}$ -inch long, 2 $\frac{3}{8}$ -

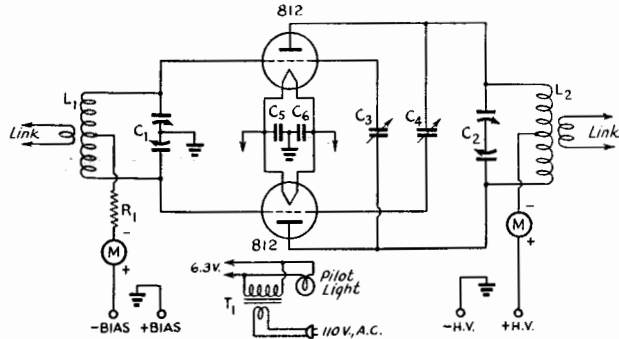

inch diam. Coil is made in 2 sections each section having 3 turns; 1 $\frac{1}{2}$ -inch space between sections (Barker and Williamson 10TVL).
56 Mc: 2 turns $\frac{3}{8}$ -inch copper tubing; $\frac{7}{8}$ -inch long, 1 $\frac{1}{2}$ -inch

diam. (Mounted on Barker and Williamson T-Plug Bar No. A62).

Swinging Link — 3 turns No. 14, spaced diam. wire, 2 $\frac{1}{2}$ -inch diam. (Barker and Williamson TV Base Assembly).

condensers are located to allow the shortest leads. The tube sockets should be mounted above the base as shown. Input and output jack strips may be seen at the right and left ends of the rear chassis wall. A high-voltage safety terminal is mounted for the d.c. input lead and the negative lead goes to the two-screw terminal strip at the center; the positive bias lead is brought to this strip also. The cord emerging at the right is the 110-volt line cord for the filament transformer.

Operation and adjustment of the amplifier are conventional. The only feature which might be confusing to an operator is that the circuit needs re-neutralizing when changing from one band to the other. This is apparently caused by some transit-time phenomena occurring in the tubes because of the high-frequency operation. A 45- or 90-volt fixed bias supply should be used in series with the grid leak during c.w. operation. The maximum grid-current rating of 50 ma. can be attained with the recommended grid resistor and 45 volts of fixed bias. If the fixed voltage is increased it is wise to lower the leak resistance. Fixed bias need not be employed for phone work.

A 100-watt modulator will supply sufficient audio for 56-Mc. operation with the amplifier running at the recommended 200-watts input. The modulator should be capable of delivering 150-watts output if the amplifier is set up as a 300-watt unit at 28 Mc. A low-impedance feed line may be connected directly to the output link or a high-impedance antenna can be coupled in by using an appropriate antenna tuner link-coupled to the final.

● A COMPACT 5- AND 10-METER TRANSMITTER

A small crystal-controlled transmitter capable of operation on either 28 or 56 Mc. is shown in Figs. 2809, 2810 and 2812. Because of its small size and power requirements (300 volts at 100 ma.) it is particularly adaptable to 56-Mc. mobile work, operating nicely from a small vibrator pack. As can be seen from the wiring diagram in Fig. 2811, one half of a 6E6 double triode is used as a crystal oscillator on 28 Mc. to drive the other half of the 6E6 as a neutralized amplifier on 28 Mc. or as a frequency-doubler on 56 Mc. A single 6F6 is all that is necessary for the audio end when work-

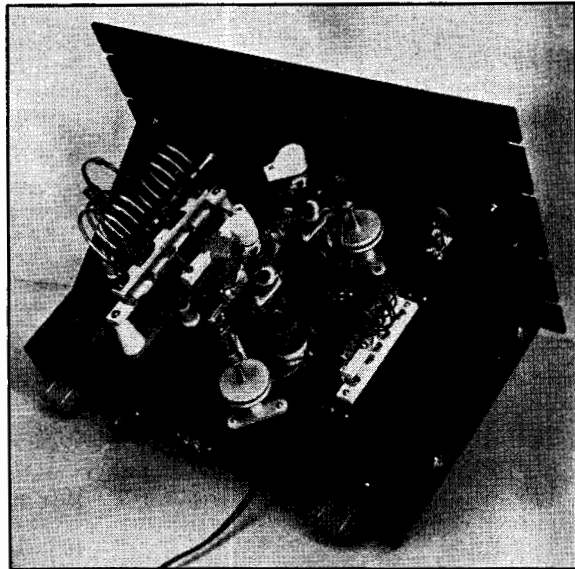

Fig. 2807 — A rear view photograph of the push-pull amplifier.

The Radio Amateur's Handbook

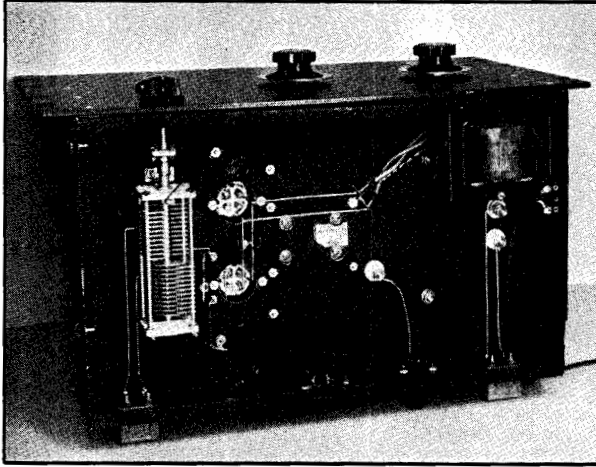

Fig. 2808 — This bottom view of the push-pull amplifier shows the placement of the grid condenser and the filament transformer. The grid leak and the filament by-pass condensers are the only other components below the chassis.

ing from a single-button carbon microphone. A meter switch allows metering of the oscillator, amplifier, or combined amplifier and modulator currents. The on-off switch on the panel also cuts the microphone current when the transmitter is not on the air.

The transmitter is housed in a cabinet 8 inches long, 7 inches high and 7 inches deep. The chassis is $1\frac{1}{2}$ inches high but is mounted slightly higher than this on the panel, to accommodate the parts more readily. Two flashlight cells mounted under the chassis furnish current for the microphone. The tuning con-

deners are insulated from the chassis by mounting them with insulating washers on the front panel, and the neutralizing condenser is insulated by mounting it on small brass pillars under the chassis. Wiring to the on-off switch, which is near the final tank coil, is run through shielding braid, to minimize r.f. pick-up. The power leads are brought to a four-prong male plug at the rear of the set, and provision for connecting to a concentric line feeding the antenna is made by bringing the antenna leads to a suitable connector at the rear of the set.

In operation, the transmitter handles as does any conventional oscillator-amplifier combination. After the oscillator has been made to work — it may be a bit tricky and the crystal may need cleaning — the amplifier is neutralized (with the plate current lead opened) and then the amplifier can be loaded and the modulation applied. With a 300-volt supply, the oscillator current and the amplifier current will each run about 30 ma., the amplifier dipping to from 5 to 20 ma. unloaded. On 56 Mc., the 5-meter final tank coil is plugged in and the circuit retuned. The dip will be much less, but the meter will clearly show the resonance point of the circuit.

A grounded quarter-wave antenna, fed at the bottom by coaxial cable, will be satisfactory for mobile work, although a half-wave antenna will give a better signal but complicates feeding.

● A TRANSMITTER FOR MOBILE WORK

A complete 28- and 56-Mc. transmitter and modulator is shown in Figs. 2813 and 2815.

To avoid the use of more than one exciter stage, and to concentrate as much power as possible in the final and modulator, a 20-meter crystal is employed in an 89 Tri-tet circuit. The 89 is not critical as to crystals and provides more than enough drive even when doubling in the 807 final, although not quite enough to permit the use of a 40-meter crystal for 5-meter operation.

The 89 doubles to 10 meters, with the 807 working straight through for 10-meter operation and doubling for 5-meter service. Actual measurements, working the 807 into a non-inductive load, show the 5-meter output to be only 20 per cent less than when working straight through on 10 meters. The actual

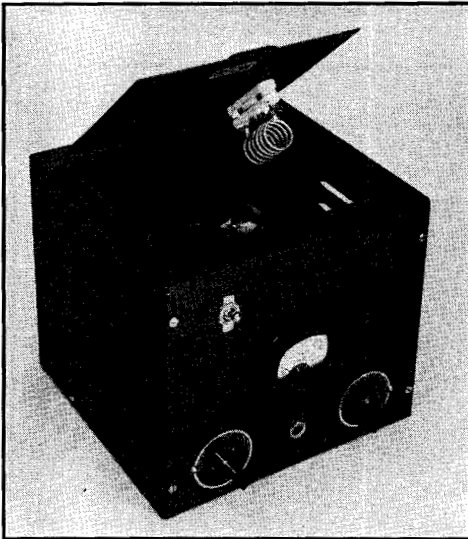

Fig. 2809 — A compact 5- and 10-meter transmitter for portable or home use. Meter switch and on-off switch at the top of the panel, and tuning condenser controls at the bottom. To prevent its loss, the final tank coil not in use is plugged in to a jack on the under side of the cabinet top.

Transmitters and Transceivers for the U.H.F.

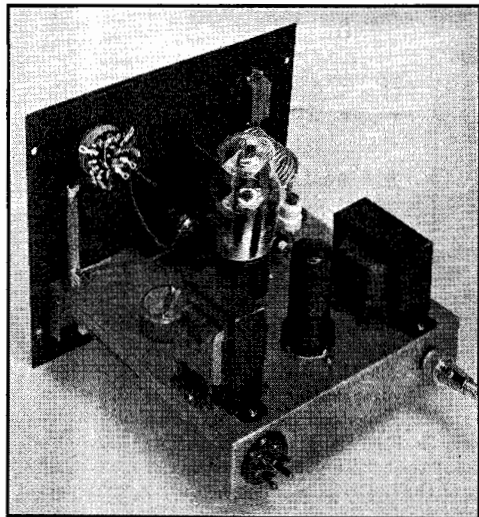

Fig. 2810 — With the cabinet removed, the placement of parts of the compact 'phone can be seen. The power plug and connector for the antenna feed line cable fit in clearing holes at the rear of the cabinet.

figures were 15 watts on 10 and 12 watts on 5; both with 28 watts into the 807.

The antenna matching network arrangement is ideally suited for mobile work, where antenna and feeder values can be almost anything — and usually are. Twisted pair, spaced pair, concentric line or single feeder — this matching network takes them all in stride. Simply by varying the capacity of C_8 , anything from a few ohms up to several hundred can be accurately matched.

The Class-B modulator using a 6N7 represents an economical arrangement for full carrier modulation. The input and output transformers are tapped to provide wide leeway for matching. The 6J5 fully drives the 6N7 when fed from a single-button carbon mike at normal voice level. Static plate-current drain for the entire audio system is between 35 and 45 ma., depending on voltage. Peak current is between 50 and 70 ma.

All connections for filament and plate supply, as well as for the microphone and microphone battery, are provided in a single plug socket mounted on the rear of the chassis. The transmitter is small enough to mount in a 14- by 8- by 7-inch Par-met cabinet as shown in the photographs. A meter on the front panel, with jacks in the oscillator and 807 cathodes and the 807 grid circuit, provide for all necessary measurements when tuning up the rig. Filament and plate switches could

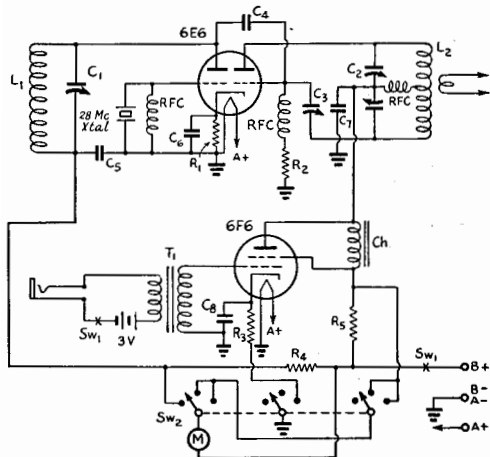

Fig. 2811 — The 6E6-6F6 5- and 10-meter 'phone.

- C_1 — 50- μ fd. midget (Hammarlund HF-50).
- C_2 — 50- μ fd. each section dual midget (Hammarlund HFD-50).
- C_3 — 15- μ fd. neutralizing condenser (Hammarlund HF-15X).
- C_4 — 0.0001- μ fd. mica.
- C_5 — 0.005- μ fd. mica.
- C_6 — 0.005- μ fd. mica. Shunted by 10- μ fd. electrolytic if any frequency-modulation is encountered.
- C_7 — 0.005- μ fd. mica or paper, 1000-volt rating.
- C_8 — 25 μ fd., 25-volt electrolytic.
- R_1, R_3 — 400-ohm, 1-watt.
- R_2 — 75,000-ohm, 1-watt.
- R_4, R_5 — 20-ohm, $\frac{1}{2}$ -watt.
- RFC — 2.5 mh. r.f. choke.
- Sw_1 — D.p.d.t. toggle switch.
- Sw_2 — Four-position three-contact switch.
- T_1 — Single-button microphone transformer (Thordarson T-86A02).
- L — 30-henry, 80 ma. choke (Thordarson T-44C02).
- L_1 — 6 turns No. 12, $\frac{1}{8}$ -inch diam., $\frac{1}{4}$ -inch long.
- L_2 — 28 Mc.: 12 turns No. 12, $\frac{3}{4}$ -inch diam., spaced diam. of wire, 56 Mc.: 6 turns No. 12, $\frac{3}{4}$ -inch diam., $1\frac{1}{8}$ -inch long.
- M — 0-100 ma.

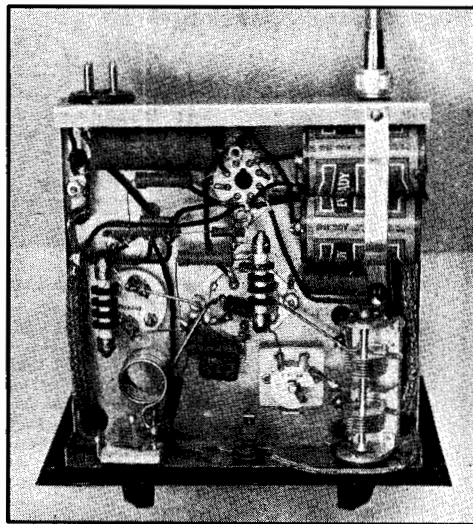

Fig. 2812 — The tuning condensers and the neutralizing condenser are mounted underneath the chassis — see text for details on mounting them.

The Radio Amateur's Handbook

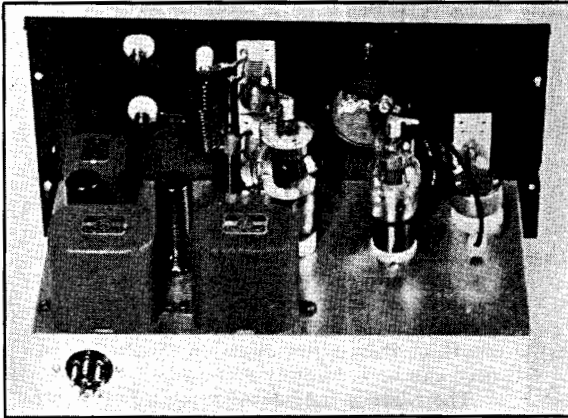

Fig. 2813 — The 89 at the right doubles from a 20-meter crystal, driving the 807 as a doubler on five or straight through on ten. The 6J5-6N7 Class-B modulator at the left provides plenty of push from a carbon mike, even with 30 watts into the 807. (W2JCR, August, 1939, QST.)

have been included in the transmitter but were omitted in favor of remote switching from the car dash (or operating table). (Bib. 1.)

● A 56- AND 112-MC. AMPLIFIER

The 56- and 112-Mc. amplifier shown in Figs. 2816, 2817 and 2819 features the new

815 dual beam-power tube. It requires only about two watts of 56-Mc. driving power to work well on either band, and can be satisfactorily excited by the transmitter shown in Fig. 2906 or any other exciter delivering comparable output. For 56-Mc. operation, only the 815 is used, and on 112 Mc. a 7C5 doubler stage is automatically cut in.

As can be seen from the wiring diagram in Fig. 2818, there is nothing unconventional about the circuit other than the neutralizing of the beam-power tube and the series-tuned plate circuit (in effect) of the 7C5. The former was found necessary for this particular tube, and the latter allows considerably more inductance to be used than would be the case

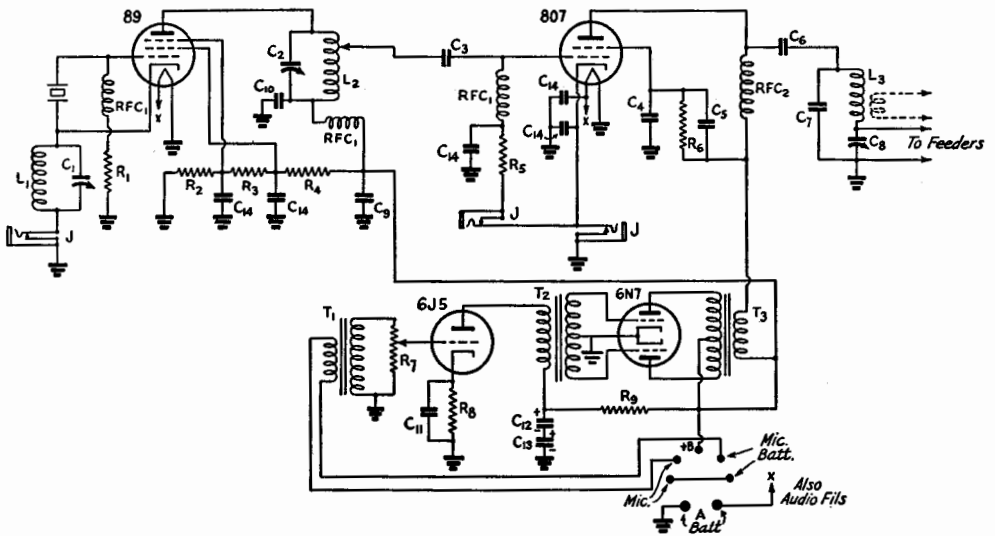

Fig. 2814 — The 89-807 transmitter circuit.

- | | | |
|---|--|---|
| C ₁ — 75- μ fd. variable (National UM-75). | C ₇ — 25- μ fd. variable (National UMA-25). | C ₁₄ — 0.01- μ fd., 400-volt paper. |
| C ₂ — 30- μ fd. variable (National UM-35). | C ₈ — 100- μ fd. variable (National UM-100). | R ₁ — 50,000 ohms, 1-watt. |
| C ₃ — 50- μ fd. mica. | C ₉ , C ₁₀ — 0.01- μ fd. paper, 600-volt. | R ₂ — 10,000 ohms, 1-watt. |
| C ₄ , C ₅ — 0.002- μ fd. mica, 400-volt. | C ₁₁ — 10- μ fd. 25-volt electrolytic. | R ₃ , R ₄ — 25,000 ohms, 1-watt. |
| C ₆ — 0.002- μ fd. mica, 1000-volt. | C ₁₂ , C ₁₃ — 4- μ fd., 450-volt electrolytic. | R ₅ — 50,000 ohms, 1-watt. |
| L ₁ — 8½ turns No. 14 enamelled, close-wound, inside diameter 1 inch. | | R ₆ — 15,000 ohms, 2-watt. |
| L ₂ — 8 turns No. 14 enam., double-spaced, inside diameter 1 inch, tapped 2½ turns from plate end. | | R ₇ — 0.5-megohm potentiometer. |
| L ₃ — 28 Mc.: 12 turns No. 12 enam., inside diameter 1 inch. | | R ₈ — 1000 ohms, 1-watt. |
| | | R ₉ — 5000 ohms, 1-watt. |
| | | 56 Mc.: 4 turns No. 12 enam., inside diameter 1 inch. |
| | | T ₁ — Single-button microphone transformer (UTC-S6). |
| | | T ₂ — Class-B input, 6J5 to 6N7 grids (UTC-S8). |
| | | T ₃ — Class-B output, 6N7 to load, tapped (UTC-S18). |
| | | J — Closed circuit jack. |

Transmitters and Transceivers for the U.H.F.

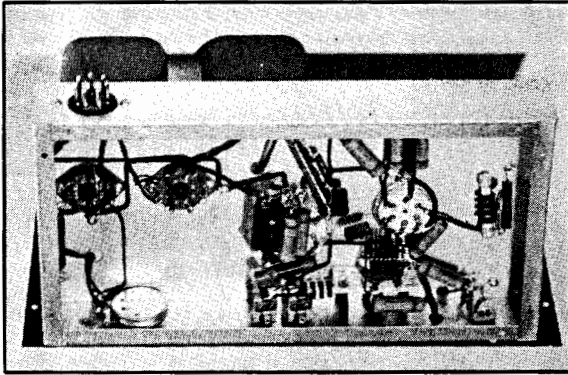

Fig. 2815 — Bottom view of the mobile transmitter. Power, mike and mike battery connect through plug at the left.

normally. Five-meter energy from the exciter can be plugged in to the coil socket for L_3 when 56-Mc. operation is desired; this automatically opens the heater lead of the 7C5 doubler and renders it inoperative. For 112-Mc. work the 5-meter excitation is plugged into the socket at the rear of the chassis, allowing energy to reach the grid of the 7C5 and also turning on its heater. Plug-in coils are used for the 815 grid and plate circuits and for the 7C5 plate circuit.

The neutralizing condensers for the 815 consist of small copper tabs, $\frac{3}{8}$ by $\frac{3}{4}$ inch, soldered on the ends of stiff wires running up through the chassis through Millen 32150 bushings and arranged to be close to the plates of the 815. Neutralizing is conventional and not at all critical.

The plate coils for the 815 are mounted on ceramic plug-in strips and provide swinging links for variable output coupling. A quarter-wavelength line would be more efficient on 112 Mc. than the coil and condenser circuit, and one could be made similarly to the one shown in Fig. 2908. The condenser should be disconnected from the plate caps of the tube when using the linear tank circuit, and the condenser can be tapped to the lines near their shorted end to provide some tuning.

The 815 can be run at 60 watts input on either 56 or 112 Mc., at 400 volts on the plate. At this input it will require a modulator capable of 30 watts output to modulate fully the output. Grid current of 3 to 5 ma. when the amplifier is loaded will indicate sufficient drive, and no advantage is obtained by increasing the excitation.

● A 112-MC. "POT" OSCILLATOR

One method of obtaining higher stability with a self-excited oscillator is the use of a "pot" oscillator as shown in Figs. 2820, 2821 and 2823. The tank circuit is made up of two

concentric shield cans and a copper rod, as can be seen from the circuit diagram in Fig. 2822. Inductive coupling to the grid is obtained by running a wire through the cans parallel to the copper rod. Power is coupled out of the circuit by a hairpin loop of wire running parallel to the rod and in the plane of a radius. Pushing the loop farther down in the pot increases the coupling. A tuning condenser is connected between plate and ground to allow the frequency to be set any place in the 112-Mc. band.

Since the pot is connected directly to the plate, the whole pot is at the d.c. plate voltage above ground, and the outer surface of the pot should be given several coats of clear lacquer as a safety measure.

The socket (Amphenol polystyrene) is sup-

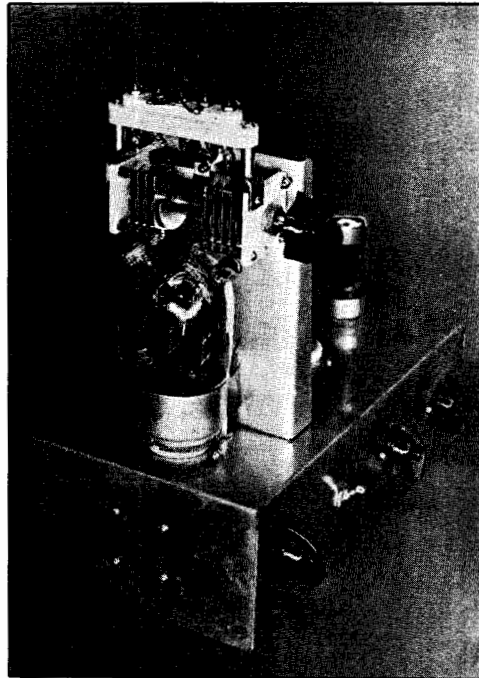

Fig. 2816 — A 56- and 112-Mc. amplifier using the 815. To insure short leads, the plate condenser is mounted on a bracket which places the condenser just over the tube. For symmetry, two straps of copper are bent around the center of the plate condenser rotor and fastened to the end-plate supports, thus effectively grounding the center of the condenser rotor. The plug-in socket for the final tank coil is mounted on the condenser with two small brass brackets.

Note the neutralizing condensers which are simply taps of copper soldered to stiff wires which support the tabs near the plates of the dual tube. Adjustment is made by moving the tabs nearer or farther away or by trimming their size — it isn't critical.

The Radio Amateur's Handbook

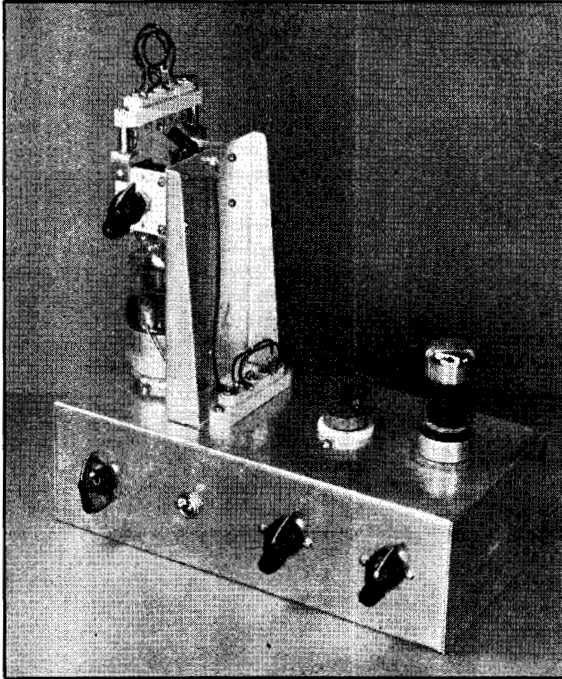

Fig. 2817 — Another view of the amplifier shows the grid coil shielded from the amplifier tube. The 112-Mc. grid coil is in the socket. The chassis measures 5 by 10 by 3 inches.

ported on top of the can by a U-shaped bracket of half-inch strap brass which is held to the can by the same screw that holds the copper rod. Another piece of brass sweated to the socket bracket supports the tuning condenser. The tuning condenser has the shaft sawed off just past the rotor plates, so that only one bearing is used, and the rear stator support is removed by unsoldering the joints.

A $\frac{1}{4}$ -inch diameter hole drilled $\frac{5}{16}$ inch in from the edge of the outer can allows the lead from the inner can to be brought up to the stator of the tuning condenser. A small lug riveted to the top of the inner can furnishes this connection. Opposite the grid terminal of the socket and $\frac{3}{4}$ inch in from the edge, a $\frac{1}{4}$ -inch diameter hole is drilled to take the grid lead, and two corresponding holes are drilled in the inner can and the bottom plate of

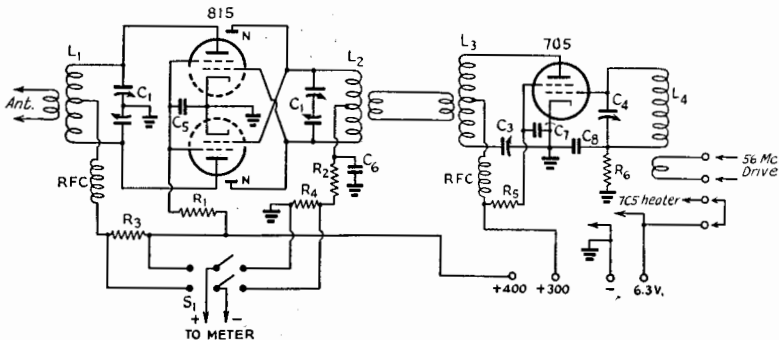

Fig. 2818 — Wiring diagram of the 815 amplifier.

- C₁ — 15 μ fd. per section (Cardwell ET-15-AD). The rotor is grounded at the center by two copper straps mounted on the end-plate support bars.
- C₂ — 10 μ fd. per section (Cardwell ER-15-AD with one stator and one rotor plate removed from each section).
- C₃ — 35- μ fd. midget variable (Cardwell ZR-35-AS).
- C₄ — 15- μ fd. midget variable (Cardwell ZR-15-AS).
- C₅ — 0.005- μ fd. mica.
- C₆ — 100- μ fd. mica.
- C₇, C₈ — 0.002- μ fd. mica.
- N — Small copper tabs near tube plates. See text.
- R₁, R₂ — 15,000 ohms, 10-watt wirewound.
- R₃ — 75 ohms, 2-watt.
- R₄ — 75 ohms, $\frac{1}{2}$ -watt.
- R₅ — 12,000 ohms, 1-watt.
- R₆ — 0.1 megohm, 1-watt.

- S₁ — D.p.d.t. toggle, for meter switching.
- RFC — 25 turns No. 24 enam., self-supporting, $\frac{1}{4}$ -inch diam. (or Ohmite Z-1).
- L₁ — 56 Mc.: 6 turns No. 14 enam., 1-inch diam., $1\frac{1}{4}$ inches long with $\frac{3}{8}$ -inch gap in center to take 2-turn link. 112 Mc.: 2 turns No. 14 enam. with 1-turn link.
- L₂ — 56 Mc.: 6 turns No. 14 enam., $\frac{7}{8}$ -inch diam., $\frac{7}{8}$ -inch long. Two-turn link of $1\frac{1}{4}$ -inch diam. wound over center. 112 Mc.: Shallow U of No. 14 enam. $\frac{5}{8}$ inch high running from strip terminals. Link is a similar winding parallel to L₂.
- L₃ — 4 turns No. 14 enam. $\frac{3}{4}$ -inch diam., $\frac{3}{4}$ -inch long. Link is 2 turns $1\frac{1}{8}$ -inch diam. wound over center of L₃.
- L₄ — 4 turns No. 14 enam. $\frac{3}{4}$ -inch diam., spaced diam. of wire. Two-turn link at cold end of L₄.

Transmitters and Transceivers for the U.H.F.

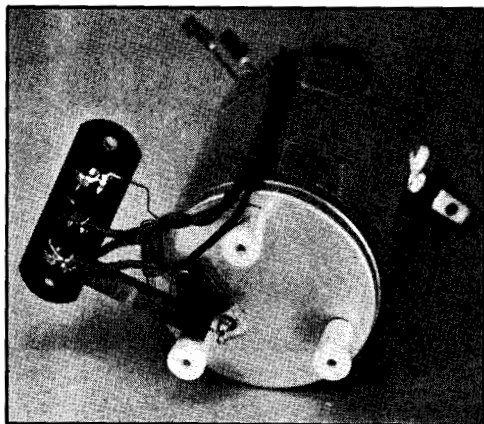

Fig. 2823—A view under the oscillator shows the grid condenser and leak, the r.f. choke and supporting pillars.

plate and filament circuits. It gives good stability and an unusually high order of efficiency for u.h.f. oscillators.

Photographs of the transmitter using this circuit are shown in Figs. 2826 and 2828. The push-pull HY-615 tubes are capable of about five watts output at $2\frac{1}{2}$ meters and somewhat less at $1\frac{1}{4}$ meters.

The aluminum chassis measures $3\frac{1}{4}$ by 16 by $1\frac{1}{2}$ inches; at one end are the tube sockets, mounted with the filament prongs facing the front edge. A soldering lug is placed under one of the socket mounting screws so that all grounds at this end of the chassis may be made to this one point.

The top view, Fig. 2826, shows the tubes mounted closely together at the left with the tuned plate line extending to the right. A homemade condenser across the tube end of the pipes permits adjusting the frequency over a fairly large range. The grids, which should be as nearly as possible at zero r.f. potential, are tied together and grounded to the chassis through the grid leak, R_1 . The antenna link is mounted on two standoff insulators at the right end of the base.

The plate-pipe assembly is supported by standoff insulators, the center of the pipes resting on one and the shorted end of the line on the other (between the two cones). Plate voltage is fed through a hole in the chassis to

this latter point. The standoffs are of sufficient height to permit the shortest possible connections between the line and the tube plates. A strip of the best obtainable r.f. insulating material should be used as the spacer and mounting support across the center of the line.

The plate tuning condenser is made from two $1\frac{1}{2}$ -inch diameter copper discs, to each of which is soldered a machine screw. The pipes are drilled and tapped so that one plate can be mounted on each pipe.

Construction of the $1\frac{1}{4}$ -meter line may be similar, but the light weight of the line suggests that only one supporting insulator be used. This may be accomplished by soldering a right-angle bracket to the shorted end of the line and attaching the assembly to the insulator used to support the center of the 112-Mc. pipes. The condenser plates for this frequency are 1 inch in diameter.

Beneath the chassis is the tuned cathode

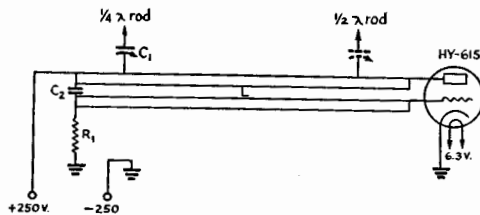

Fig. 2825—Circuit of the low-power oscillator shown in Fig. 2824.

- C_1 —30- μ fd. isolantite-insulated compression-type trimmer.
- C_2 —100- μ fd. midget mica.
- R_1 —50,000 to 75,000 ohms, $\frac{1}{2}$ -watt.
- L—Linear tank circuit; see text.

circuit, connected to the cathode prongs of the tube sockets by short lengths of No. 12 wire. The pipes are shorted and grounded to the chassis at the far end. C_1 , the tuning condenser, is insulated from the chassis and connected directly across the open end of the line. Each tube has a separate set of twisted pair filament leads running through its cathode pipe; they are connected in parallel for the heater power, of course.

In tuning to the $2\frac{1}{2}$ -meter band, first set the plate condenser C_2 so that the spacing between plates is approximately $\frac{3}{16}$ inch. Then apply power and rotate the filament condenser, C_1 , until oscillation starts, indicated by a drop in

Fig. 2824—This low-power transmitter illustrates the simplicity of construction of the 112- and 224-Mc. hands. The circuit diagram is given in Fig. 2825.

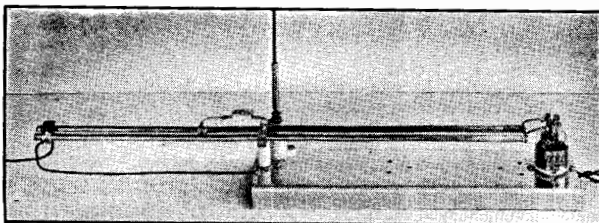

The Radio Amateur's Handbook

plate current. The oscillating plate current should be about 20 ma., rising, when the antenna is coupled, to about 40 ma. A reliable frequency checking system should then be used to make sure that the transmitter is tuned to the desired frequency. The frequency is lowered by increasing the plate condenser capacity and retuning the filament circuit. Decreasing the plate capacity increases the frequency.

For $1\frac{1}{4}$ -meter operation, in addition to replacing the larger plate pipes by smaller ones, a section of the cathode line may be shorted by a metal slider, the position of which should be adjusted so that C_1 is effective in tuning. It should, however, be possible to find resonance on this band simply by tuning C_1 carefully in the region near minimum capacity, since the line is rather short for $2\frac{1}{2}$ meters.

● MEDIUM-POWER TUNED-PLATE TUNED-FILAMENT TRANSMITTER

Figs. 2829 to 2831 show the construction and circuit of a second tuned-plate tuned-filament $2\frac{1}{2}$ -meter transmitter. This set has much in common with the one just described, but conventional tubes of the medium-power class are employed. Fundamentally the circuit of Fig. 2830 is the same as that of Fig. 2827, with slight changes made necessary by the directly-heated type of tube used. This arrangement, even with conventional tubes, operates with an efficiency of better than 50 per cent.

A glance at Fig. 2829 will show the arrangement of the plate circuit, supported on top of the chassis. The chassis is $4\frac{1}{2}$ inches wide, 15 inches long and $2\frac{1}{2}$ inches deep. There is no tuning condenser for the plate line; a condenser may be used, if desired, but for best efficiency

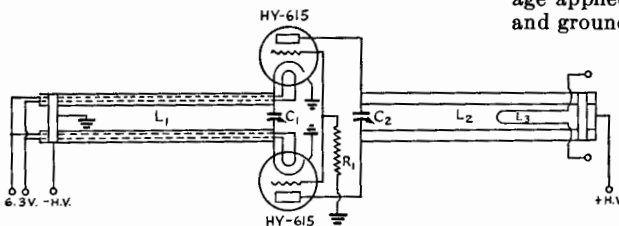

Fig. 2827 — Circuit diagram of the low-power tuned-plate tuned-filament oscillator.

- C_1 — 15- μ fd. variable (National UM-15).
- C_2 — See text.
- R_1 — 20,000 ohms, 1-watt.
- L_1 — Filament line, $\frac{1}{4}$ -inch o.d. copper tubing, length 10 inches, spacing $\frac{5}{8}$ inch.
- L_2 — Plate line; for 112 Mc., 7 16-inch o.d. copper tubing, length 14 inches; spacing diameter of tubing; for 224 Mc., $\frac{1}{4}$ -inch o.d. copper tubing, length 6 inches, spacing diameter of tubing.
- L_3 — Hairpin link for antenna coupling; length approximately $4\frac{1}{2}$ inches.

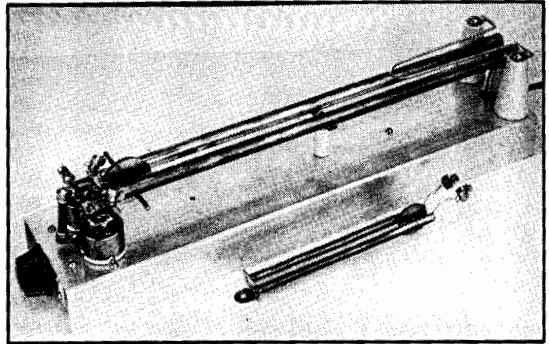

Fig. 2826 — a low-power tuned-plate tuned-filament oscillator. For operation on 112 and 224 Mc. The small line in front is for 224 Mc.

it should be omitted. The line is relatively short for the frequency, the reason being that the internal tube leads make a considerable addition to the actual length of the line, plus the loading effect of the tube plate-grid capacity.

The high-voltage connection, brought through an insulator in the chassis, is shown just to the left of the supporting insulator in Fig. 2829. The antenna-coupling link, L_3 , is made from small-diameter copper tubing; its length should be adjusted to give the desired loading, with the antenna used.

Fig. 2831 is a view of the tuned filament circuit underneath the chassis. Each pipe is soldered to and partly supported by a filament prong on each tube socket. The shorted end of the line is held in place by a metal pillar which also makes the connection to the chassis ground. A wire is fed through each pipe and connected to the other filament prong on the appropriate socket. These wires are connected together at the shorted end and filament voltage applied between this common connection and ground.

C_1 , the filament-line tuning condenser, rests on the insulated portions of the sockets and is securely mounted by two small aluminum brackets which fit under the socket mounting screws. Care must be taken to prevent grounding of the condenser plates.

A short connection is made between the two grid prongs, and the grid resistor, R_1 , runs from the center of this connection to ground.

Tuning is similar to that already described for the low-power transmitter. The setting of C_1 which gives minimum plate current is not, however, the adjustment at which the circuit delivers maximum output. A lamp dummy antenna coupled to the pipes will show that as the condenser setting is slightly altered the

Transmitters and Transceivers for the U.H.F.

Fig. 2828 — Filament-circuit view of the low-power push-pull oscillator. The tuned filament line is grounded at one end and soldered directly to the cathode prongs of the tube sockets at the other. Filament leads run inside the tubes.

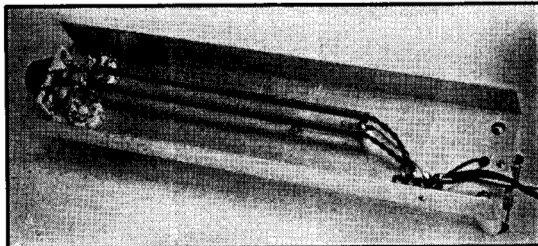

plate current will rise and the output will increase. The current should not be allowed to exceed 200 ma. at full load.

Other tubes than the T-40's shown have been used successfully in this circuit, including Types 809, T-20, RK-32, RK-11, RK-12, and TZ-40. Still others of similar construction and ratings undoubtedly also would function satisfactorily. Tubes like the HK-24 and 35T will work well at 224 Mc. using this circuit.

● TRANSMITTER-RECEIVERS AND TRANSCEIVERS

For portable or mobile work, it is necessary to have compact receivers and transmitters capable of working from small power supplies. Any one of several of the transmitters described earlier in this chapter can be combined with any of several of the receivers or converters described in Chapter Twenty Seven for the portable/mobile station. However, it is often convenient to combine both units in the same case, and several such units are described in the following pages. It is possible in these combined units to combine the functions of some of the tubes and use them during both reception and transmission. When the same tube is used for both the receiving detector and the transmitting oscillator, the unit is

called a "transceiver"; both receiver and transmitter combined in the same cabinet is called a "transmitter-receiver."

● A COMPLETE BATTERY-OPERATED 56-MC. PORTABLE STATION

The transmitter-receiver shown in Figs. 2832, 2833 and 2835 is completely battery-operated and will give excellent results on the 5-meter band. It fully complies with the regulations and is modern in every way. As can be seen from the circuit diagram in Fig. 2834, the transmitter r.f. circuit uses a 1J6G twin triode as a 28-Mc. crystal oscillator (or tuned grid for self-excited operation) and 56-Mc. doubler. A 1F5G straight r.f. amplifier having 4 watts input follows. The receiving circuit uses a 1D5GP tuned r.f. stage which greatly improves selectivity and prevents radiation. A standard superregenerative detector is used, and the tuning controls are ganged. The common audio channel makes use of a 1H4G first audio for amplifying the output of the detector or of the microphone and a 1J6G in Class B delivering 2 watts of audio.

Four tubes only are used at any time. The other two have their filaments opened by the send-receive switch when not in service. This same switch throws the antenna from the transmitter to the receiver. As the transmitter filaments take somewhat higher current than do those of the receiving tubes, a small network of $\frac{1}{2}$ -watt resistors is inserted automatically when the send-receive switch is thrown.

An additional refinement in the form of screwdriver-slot tuning of the transmitter circuits prevents accidental detuning that may occur when knobs are used. The insulated tool is clipped to the side of the case, where it is always handy.

The transceiver shown measures $12\frac{1}{2}$ inches high by 15 inches wide by 5 inches deep, holds all batteries, and weighs 15 pounds less batteries. The user has the choice of employing batteries having a combined weight of $11\frac{3}{4}$ or $5\frac{3}{4}$ pounds. The heavier batteries are somewhat cheaper and give slightly greater life than do the lighter-weight batteries. The heavier type 45-volt batteries are Burgess No. 5308 and Eveready 762. The lighter types are

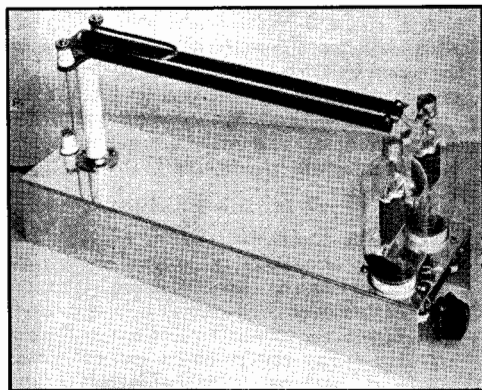
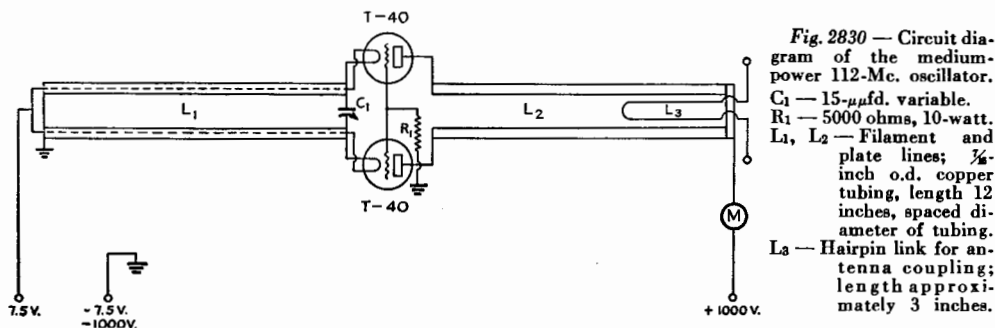

Fig. 2829 — This transmitter operates efficiently with conventional tubes at 112 Mc. To reduce losses, the plate lines are not condenser tuned. A slider is used for frequency adjustment. The hairpin coupling link is at the left.

The Radio Amateur's Handbook



Burgess Z-30-NX and Eveready No. 482. Two 1½-volt portable "A" batteries like the Burgess 4FA or Eveready 724 are recommended for filament supply.

The general layout of the unit is shown quite clearly in the various photographs, and needs little description. The receiver section is at the right, with the r.f. amplifier at the rear of the aluminum shelf. A baffle shield separates it from the detector circuit, which is next the panel. The two audio tubes are in the center, while the transmitter occupies the left-hand (from the rear) part of the chassis. The two tubes, oscillator-doubler and amplifier, are along the rear edge of the chassis. The crystal tank circuit is underneath, and the doubler tank circuit on top, of the shelf.

Connect the proper batteries and rotate the combined filament rheostat, filament and high-voltage switch sufficiently to the right for the superregenerative hiss to be heard in the "receive" position. This usually occurs in the neighborhood of 1.8 to 2.0 volts.

Next turn the switch to the "send" position and the meter switch to the "oscillator-doubler" side. The meter will read about 50 ma. with a tuned grid coil, and by checking the output with a 2-volt pilot lamp and two-turn pickup loop, the current can be reduced to 40 ma. by grid tuning without sacrifice of output as indicated by the pickup loop. When operating with a 10-meter crystal the total current will

be about 15 ma. out of resonance, and will rise to 40 ma. when the crystal frequency is reached by tuning the oscillator plate tank.

When the oscillator is "putting out" nicely, the doubler condenser is rotated for a dip of 10 ma. in the total plate current read on the meter. The oscillator and doubler now take 30 ma. Should these values not be attained when using 135 volts on the plates, tap the lead from C₁₁ to L₂ a turn or two from the hot end of the coil, and also tap down the wire from C₅ to L₃ until the doubler dips 10 ma. when C₇ is resonated.

Now throw the meter switch to the amplifier, where it will read 35 ma. out of resonance and 10 ma. when the plate tank condenser C₂ is in tune, and antenna disconnected. Connect the quarter wave antenna and tune the antenna condenser C₁ for maximum rise in plate current. Retune the plate tank condenser for a new dip and repeat the process until the amplifier draws about 30 ma., or a power input of 4 watts.

A 2-volt 60-ma. (No. 48) pink-bead pilot lamp may be connected in the circuit between the "send" side of switch SW₁ and C₁. The lamp will light to full brilliancy and may even burn out on voice modulation. If it does it is a sign of good output and the lamp may be replaced with a 6-volt 150-ma. (No. 40) brown-bead bulb. No difference has been observed in the signal by the introduction of the lamps, and as they give a real indication of current flowing in a feederless antenna system they can replace expensive thermo-couple milliammeters in portable gear. (Bib. 3)

A 112-Mc. Transceiver

The transceiver shown in Figs. 2836, 2837 and 2839 is completely self-contained and is capable of good communication over considerable distances on the 2½-meter band. It can be assembled for less than twenty dollars, including tubes and batteries, weighs about sixteen pounds, and — something not usually found in transceivers — spreads the 112- to 116-Mc. band over practically the whole tuning-condenser scale.

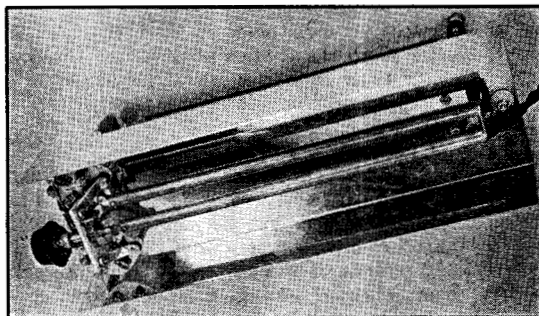
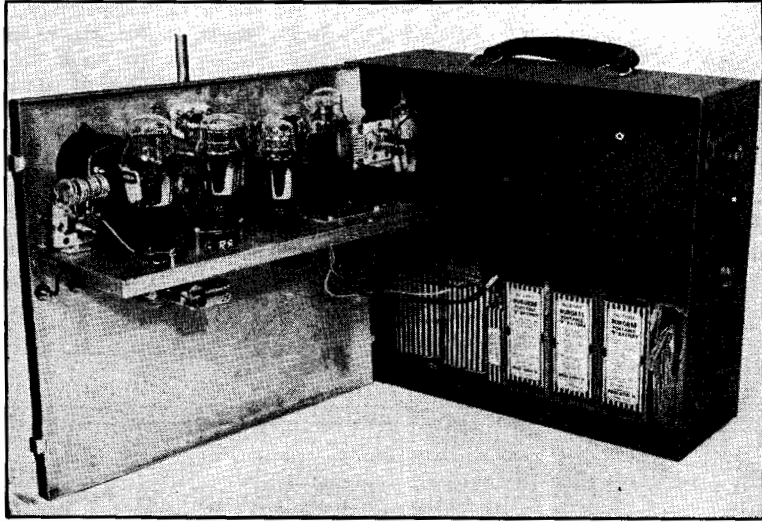

Fig. 2831 — Below-chassis view of the medium-power oscillator. The arrangement is described in the text.

Transmitters and Transceivers for the U.H.F.

Fig. 2832 — The battery-operated transceiver opened up to show how the space inside the carrying case is utilized. Transmitter and receiver are built on an aluminum shelf running the length of the panel.



The tubes used have 6.3-volt heaters, which may seem a bit odd in a unit intended for dry-battery operation. This, however, was a matter of necessity rather than choice — necessity, that is, if sure-fire and non-critical operation

was to be expected. The 6.3-volt tubes permit the transceiver to be readily adapted to a.c. operation, which will conserve battery life if the outfit is to be used at the fixed station.

As the circuit diagram shows, an HY-615 is used as the oscillator-detector, and a 6G6G as the modulator-audio amplifier. The HY-615 functions well in u.h.f. circuits, and the 6G6G makes an excellent audio tube for the purpose, giving high output with small input.

The detector-oscillator tuned circuit consists of C_2 , C_3 and L_1 . The circuit works best with fairly high C , and C_2 provides this capacity. C_3 , tapped across one-half of L_1 , serves as a band-spread tuning condenser. The incoming signal and the d.c. voltage are both fed in at the center-tap on L_1 . This is the best place for connecting the d.c. lead, and connecting the antenna at the same point affects the circuit least while still providing sufficient coupling. Converting from superregeneration to straight

oscillation is accomplished by shorting out the larger of the two grid-leak resistances, R_2 , by a set of contacts on the ganged send-receive switch. A second set of contacts connects the HY615 plate to the plate winding of the transceiver transformer, for receiving, or to the 6G6G plate circuit for transmitting. A third set of contacts grounds one side of the microphone jack during the transmission period. R_5 is the regeneration control as well as the volume control.

The cabinet which houses the unit measures 6 inches deep, 7 inches wide, and fifteen inches high. If longer battery life is desired, it will be advisable to secure a larger cabinet so that several filament batteries may be paralleled. The 6 by 7 by 15 size will permit at least two batteries to be employed.

A commercial channel-type chassis is used in conjunction with the cabinet. It can be easily duplicated by bending a piece of aluminum sheet. The width is $5\frac{3}{4}$ inches and the depth $5\frac{1}{2}$ inches. A $1\frac{1}{2}$ inch section is bent down along the panel edge for mounting. Side pieces $\frac{1}{2}$ inch wide are bent down along the two short edges to add strength and rigidity.

A view of the panel and battery compartment of the transceiver is shown in one

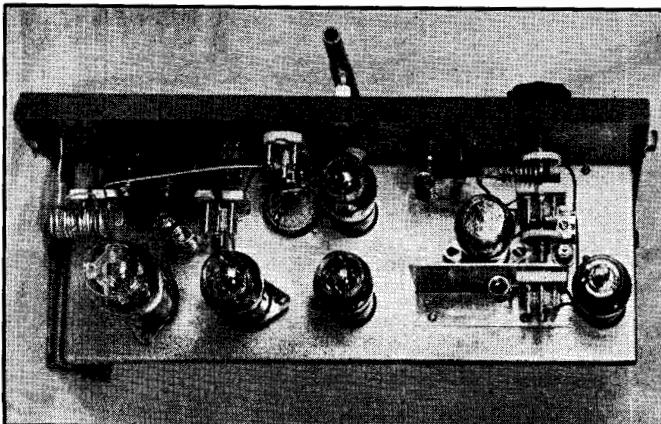

Fig. 2833 — A plan view of the outfit. Transmitter at left, receiver at right. A quarter-wave rod antenna fits into the receptacle mounted by standoff insulators on the front panel.

The Radio Amateur's Handbook

of the photos. The main tuning dial turns a bakelite shaft which runs through a bearing centered on the panel $2\frac{3}{8}$ inches down from the top edge. The two antenna support insulators are to the right, the lower one in line with the shaft bearing and the top one $1\frac{1}{2}$ inches

above; both are $\frac{7}{8}$ inch in from the right edge. The volume control, at the left, and the selector switch at the right, are mounted $1\frac{3}{4}$ inches from the edges of the panel and $5\frac{1}{4}$ inches down from the top. After these two holes have been drilled, holes of the same size and spacing

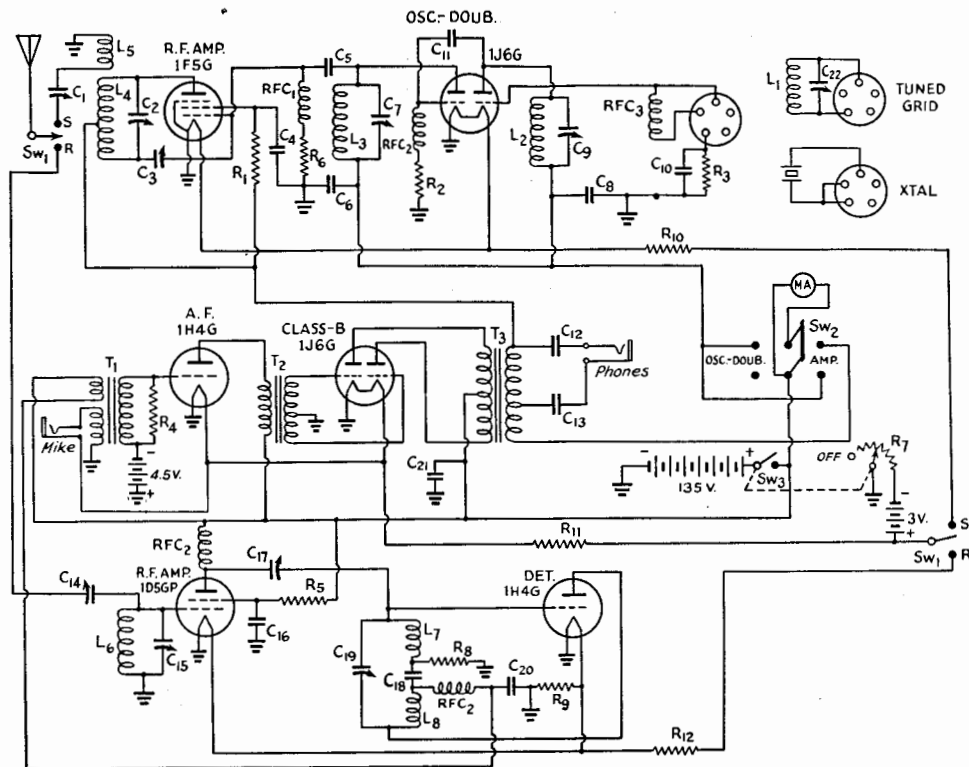

Fig. 2834 — Complete wiring diagram of the battery-operated 56-Mc. transceiver.

- C₁ — 25 μ fd. midget.
- C₂, C₇ — 15- μ fd. midget.
- C₃ — Neutralizing condenser (National NC600); not required in some layouts.
- C₄, C₆, C₈, C₁₆, C₂₀ — 0.004- μ fd. paper.
- C₅, C₁₁ — 100- μ fd. mica.
- C₉ — 35- μ fd. midget.
- C₁₀ — 250- μ fd. mica.
- C₁₂, C₁₃ — 0.1- μ fd. paper.
- C₁₄ — 50- μ fd. mica padder.
- C₁₅, C₁₉ — 10- μ fd. midget.
- C₁₇ — 50- μ fd. mica variable padder.
- C₁₈ — 100- μ fd. mica.
- C₂₁ — 8- μ fd. electrolytic.
- C₂₂ — 50- μ fd. air padder, mounts in L₁ plug-in coil form.
- R₁, R₃ — 5000 ohms, $\frac{1}{2}$ -watt.
- R₂, R₆ — 10,000 ohms, $\frac{1}{2}$ -watt.
- R₄ — 500,000 ohms, $\frac{1}{2}$ -watt.
- R₅ — 30,000 ohms, $\frac{1}{2}$ -watt.
- R₇ — 10-ohm rheostat with off position on wire and snap switch on back.
- R₈ — 100,000 ohms, $\frac{1}{2}$ -watt.
- R₉ — 8 ohms, 1-watt.
- R₁₀, R₁₁, R₁₂ — 1 ohm, $\frac{1}{2}$ -watt.
- T₁ — Mike and plate-to-single-grid transformer (high-ratio type).
- T₂ — Class-B input transformer for 1J6G.

- T₃ — Class B output transformer, 1J6G plates to 3500 and 5000 ohms.
- SW₁ — D.p.d.t. rotary switch.
- SW₂ — D.p.d.t. toggle switch.
- SW₃ — S.p.s.t. snap switch (see text), dashed lines indicate ganging.
- L₁ — Optional 28 Mc. grid coil. 9 turns No. 12 wound on $\frac{5}{8}$ -inch diameter form, spaced with No. 14; inserted in interior of plug-in coil form.
- L₂ — 28-Mc. oscillator tank — same as L₁ but not plug-in.
- L₃ — 56 Mc. doubler tank. 7 turns No. 15 on $\frac{3}{8}$ -inch diameter form, spaced with No. 14.
- L₄ — 56 Mc. amplifier tank. 6 turns No. 12 on $\frac{5}{8}$ -inch diameter form, spaced with No. 14; center tapped.
- L₅ — 4 turns No. 12 on $\frac{5}{8}$ -inch diameter form spaced with No. 14, wound over L₄ or 2 turns at each end.
- L₆ — 7 turns No. 14 on $\frac{3}{8}$ " dowel to occupy 1" — remove dowel.
- L₇, L₈ — 6 turns No. 14 on $\frac{3}{8}$ " dowel to occupy 1". Space between coils should be greater than 1", inductive relation not required.
- RFC₁ — 2.5-mh. r.f. choke.
- RFC₂ — 70 turns No. 30 d.s.c. on $\frac{3}{8}$ " dowel (wood) that has been boiled in paraffine. Paint winding with low-loss coil dope.

Transmitters and Transceivers for the U.H.F.

Fig. 2835—Bottom view, showing the wiring. Audio transformers are below the chassis. The speech system is for use with a single-button mike.

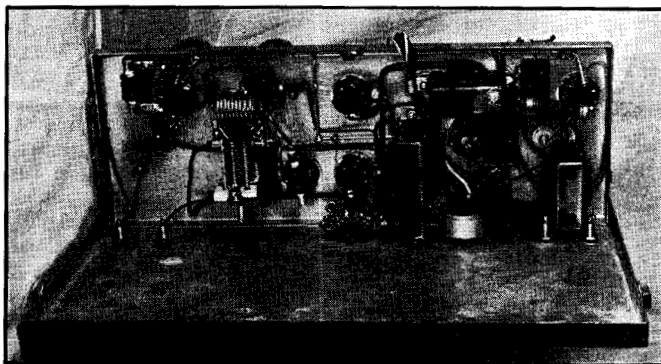

should be drilled in the supporting section of the chassis. Later, when the components are mounted, the variable control and the switch are used to fasten the panel and chassis together. Jacks for the headset and microphone are $1\frac{1}{4}$ inches below the controls just mentioned and $2\frac{3}{4}$ inches in from the panel edges.

The HY-615 is mounted at the center of the chassis. The grid-cap of the tube is to the left. A socket for the 6G6G is centered 1 inch in from the rear chassis edge and just behind the HY-615. The modulation transformer is to the left of the tubes.

Compactness in the detector-oscillator mechanical layout is the only real objective. This is easily attained by mounting the band-spread condenser on a $1\frac{3}{8}$ -inch stand-off insulator (Millen type 30001) which keeps the condenser clear of the tube. The condenser, with all but three plates removed, is first fastened by running a 6-32 machine screw through the inside of the insulator and through the condenser-frame mounting hole. This assembly may be placed quite close to the tube provided the condenser mounting is reversed so that the mounting hole comes under the shaft at the front rather than under the plates at the rear. The insulator may then be placed so that the mounting ring barely touches the tube base. A

shaft coupling connects the condenser to the bakelite extension shaft.

Next, C_2 and L_1 are paralleled and one end of the combination is soldered to the left-hand stator terminal of C_3 . This should be a solid connection because it is the main support of C_2 and L_1 . The opposite end of this combination is supported by C_4 , which also connects to the grid cap of the HY-615. C_1 , the antenna coupling condenser, mounts between the rotor terminal of C_3 and the antenna feed-through insulator. A second connection runs from the rotor of C_3 to the center of L_1 to form the band-spread tap. The d.c. voltage, which comes up through the r.f. choke at the right, is also fed in at the tap on L_1 . Another r.f. choke, in series with the grid leaks, connects to the grid of the tube. Both the grid and plate chokes are attached to victron through-point bushings mounted in the chassis to the front of the tube. The plate and grid connections are soldered to the tube caps to insure good contact, since the small spring clips are not always reliable.

However, soldering is not absolutely necessary, and is not recommended unless the builder is prepared to be careful to use just enough heat to make the connection. Otherwise the tube may be damaged.

The wiring below the chassis needs no particular care. Of course, r.f. by-pass leads must be as short and direct as possible. Fortunately, there is little opportunity to go wrong, so long as the two 0.01- μ fd. paper condensers are mounted as shown. The ground sides connect to a lug held in place by the nut

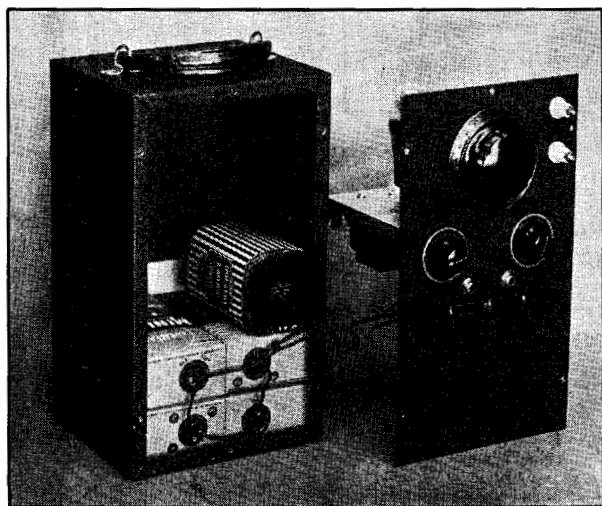

Fig. 2836—A front view of the transceiver panel layout and the battery compartment. The antenna is a half-wave rod; the upper of the two insulators is only a support.

The Radio Amateur's Handbook

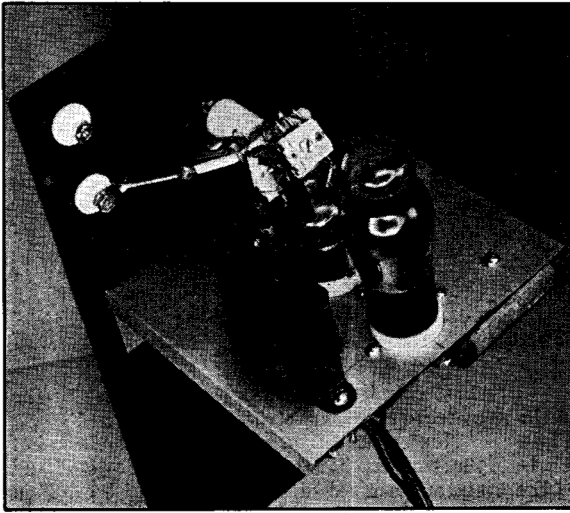

Fig. 2837 — Looking down into the r.f. circuit. The hand-spread condenser is tipped as shown so that it may be adjusted from the rear after the panel and chassis have been slipped in the case.

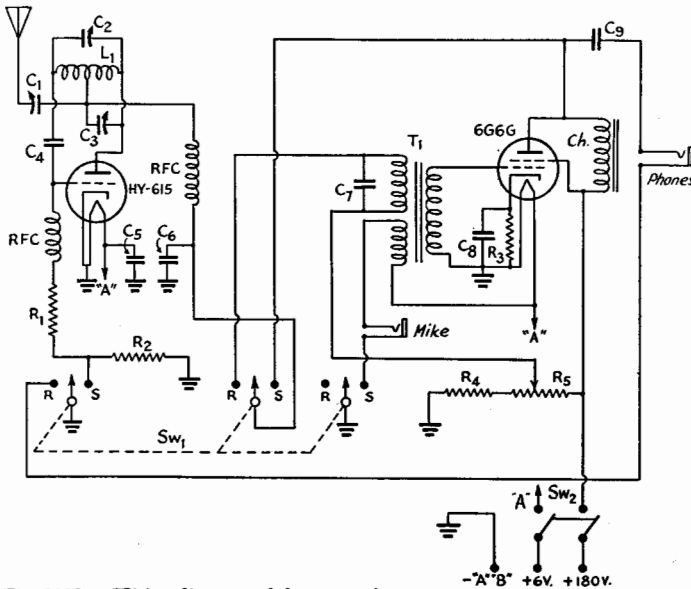

Fig. 2838 — Wiring diagram of the transceiver.

- C₁, C₂ — 30- μ fd. mica trimmers (National M30).
- C₃ — 3-plate midget variable (Hammarlund HF-15 with two plates removed).
- C₄ — 100- μ fd. midget mica.
- C₅, C₆ — 0.01- μ fd., 600-volt paper.
- C₇ — 0.002- μ fd. midget mica.
- C₈ — 20- μ fd., 25-volt paper electrolytic.
- C₉ — 0.25- μ fd., 400-volt paper.
- R₁ — 15,000 ohms, $\frac{1}{2}$ -watt.
- R₂ — 125,000 ohms, $\frac{1}{2}$ -watt.
- R₃ — 500 ohms, 1-watt.
- R₄ — 100,000 ohms, $\frac{1}{2}$ -watt.

- R₅ — 100,000-ohm variable.
- RFC — High-frequency r.f. chokes (Ohmite Z-1).
- T₁ — Transceiver transformer (Thor-darson T-72A59).
- Ch — 7-henry, 40-ma. filter choke (Thor-darson T-13C37).
- Sw₁ — 4-circuit single-gang selector switch (Yaxley 3243) with one set of contacts not used).
- Sw₂ — D.p.s.t. snap switch (Yaxley No. 7 mounted on variable resistor).
- L₁ — 3 turns No. 14 tinned wire, $\frac{1}{2}$ -inch diameter, $\frac{5}{8}$ -inch long.

which locks the tube socket in place. The transceiver transformer is at the left, with the grid winding facing the tube sockets. C₈ and R₃ are at the rear of the chassis. C₉ is the large paper condenser at right angles to C₈. R₁ runs between the selector switch and the through-point bushing at the right. R₂ goes from the switch to ground (the soldering lug). Sw₂ is mounted on the potentiometer and connects to the lug strip at the rear of the chassis. Incoming voltage leads are attached to this same strip.

Four Eveready Mini-Max type 482, 45-volt blocks form the plate supply. The Burgess type F4P1, 6-volt battery is used for the filament supply. One of these 6-volt units will permit twenty-two to twenty-five hours of operation. With a larger cabinet, three of these blocks could be paralleled so that sixty or more hours of service could be secured.

To put the transceiver in operation, the battery leads are soldered in place, an antenna (the length is not critical, but it should be around 45 inches) is attached, and the 'phones and microphone are plugged in the appropriate jacks. Resistor R₁ is then rotated in a clockwise direction to full scale. This snaps on the plate and filament switches and sets the regeneration and volume at maximum. Sw₁ should be thrown to the receive position.

After a second or two of warming up, the superregenerative hiss should become audible. It is probable that the detector will superregenerate properly only at frequencies in and near the 2 $\frac{1}{2}$ -meter band, which will be found with C₂, the band-setting condenser, at nearly full capacity. A quarter turn back from maximum capacity should be quite close to the band.

The band-spread adjustment is quite easily made because of the construction of the coil. In our model the band could be

Transmitters and Transceivers for the U.H.F.

spread over the entire dial when the band-spread tap was placed at the exact center of the coil. Less spread is obtained with the tap more toward the grid end of the coil and more when the tap is moved back toward the plate end.

It may be well to experiment a bit with the position of the d.c. voltage tap, as sometimes a considerable improvement will result. It is also worthwhile to try different values of grid-leak resistance. A point closer to straight oscillation is reached as the value of the resistance is decreased.

The oscillator is not at all seriously affected by antenna loading, but it is advisable to spend a few minutes trying different adjustments because proper loading does permit the circuit to work at its best. A setting which allows approximately three-quarters of the coupling condenser capacity to be used is about optimum. (*Bib. 4.*)

A 112-Mc. Transmitter-Receiver

The transmitter-receiver shown in Figs. 2840, 2842 and 2843 uses the new 1.4-volt filament loktal tubes for good u.h.f. performance and minimum battery requirements. Because the plate voltage is low (90), every effort was made to reduce the losses throughout the rig. Ceramic and polystyrene insulation is used wherever possible, and the parts are arranged for maximum efficiency.

As can be seen from the circuit diagram in Fig. 2841, separate 1LE3's are used for detector and transmitter oscillator, with a 1LA4 serving as audio amplifier and modulator. A switch on the panel turns off the filament battery when the set is not in use, and another switch is used for the "send-receive" changes. The only unusual feature of the circuit is that no regeneration control of the usual type is used, but a tuned antenna coil can be moved in relation to the grid coil and provides an effective control of regeneration.

The unit is housed in a 7 by 15 by 3-inch chassis which provides just enough space for the components. The tube sockets and tuning condensers are mounted on a 7 by 3-inch strip of aluminum supported by strips of $\frac{1}{4}$ -inch brass rod and mounted $2\frac{3}{4}$ inches down from the top of the chassis. This allows just enough room to get the tubes in and out of their sockets. The condensers are insulated from the chassis by National XS-6 bushings, and the shafts are connected to the dials through bakelite insulating couplings. The variable antenna coupling is made by drilling a piece of $\frac{1}{4}$ -inch bakelite rod so that it will take the ends of the antenna coil, L_3 , and mount the condenser C_4 . The wire is secured to the shaft by Duco cement. A shaft bushing furnishes the bearing for the shaft, and an insulated washer

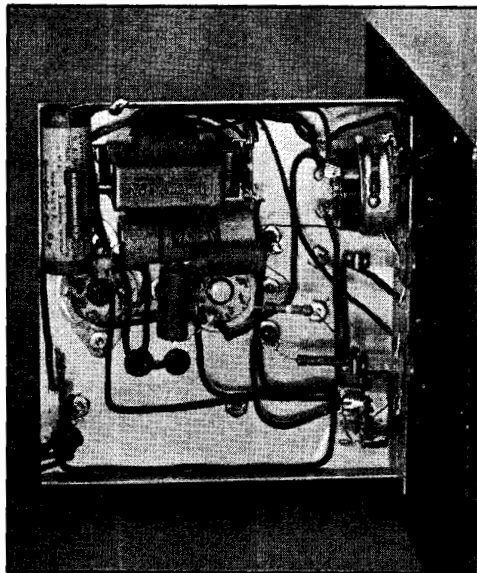

Fig. 2839 — A view of the parts and wiring below the chassis. The grouping of "grounds" is the only important consideration here. See text for details.

between the shaft bushing and one side of the coil prevents the coil from shorting against the bushing. A short piece of flexible wire from the antenna switch to the coil furnishes some drag, and a spring washer on the shaft provides enough additional drag to allow the coil to be set in any position without moving. It is not a very critical setting and does not need to be varied often.

The send-receive switch is modified to provide a low-capacity antenna switch, to eliminate coupling between the transmitter and receiver circuits. One gang of a two-gang three-circuit two-position switch is removed, and the switch bar is tapped for two 4-36 screws. A strip of polystyrene is bolted to this bar and serves as the extension arm for the antenna switch. It passes through a slot in the sub-chassis. A strip from an old phone jack is drilled and bolted to the polystyrene strip to furnish spring and contacts for the switch. The receiver and transmitter contacts are made from brass strips supported by feed-through insulators and mounted on the aluminum sub-chassis. The length of these strips is adjusted so that the switch arm will just make contact. A piece of flexible wire or braid runs from the antenna post to the switch arm. The antenna post is made by mounting a Johnson jack on a Millen polystyrene stand-off insulator. The flexible lead is insulated where it goes through the top of the chassis by running it through a small piece of polystyrene. The antenna is a 4-foot car antenna, and it is

The Radio Amateur's Handbook

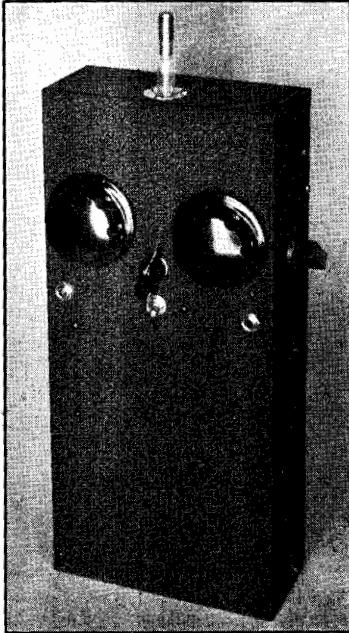

Fig. 2840 — A self-contained 112-Mc. transmitter-receiver. The two large knobs are for tuning the receiver and transmitter, the knob between them is the "send-receive" switch, and the toggle switch turns off the filament battery. A jack mounted on a polystyrene stand-off insulator provides a convenient point to plug in the vertical antenna. The knob on the side of the chassis controls the regeneration in the receiver by varying the antenna coupling.

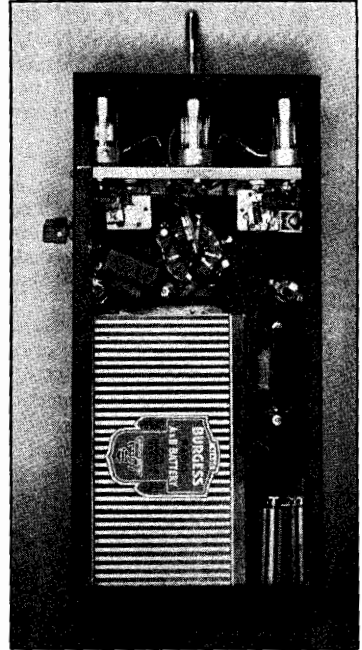

Fig. 2842 — The rear view of the transmitter-receiver shows the position of the batteries and the sub-chassis which supports the tubes and tuning condensers.

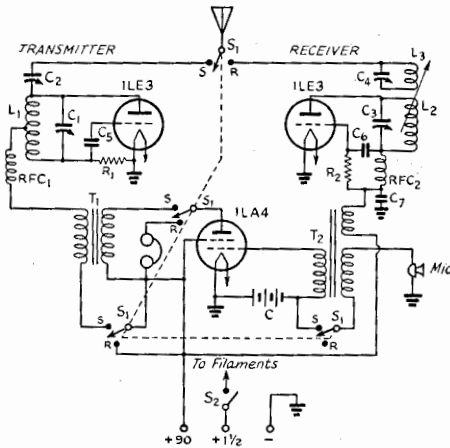

Fig. 2841 — Circuit diagram of the 112-Mc. transmitter-receiver.

- C₁ — 15- μ fd. midget variable (Hammarlund HF-15).
- C₂ — 3-15- μ fd. mica compression trimmer (National M-30 with top plate trimmed down).
- C₃ — 6- μ fd. midget variable (Hammarlund HF-15 with one rotor and two stator plates removed).
- C₄ — 3-30- μ fd. mica compression trimmer (National M-30).
- C₅, C₆ — 50- μ fd. mica.
- C₇ — 500- μ fd. mica.
- R₁ — 12,000 ohms, $\frac{1}{2}$ -watt.
- R₂ — 5 megohms, $\frac{1}{2}$ -watt.
- T₁ — Push-pull interstage transformer (Thordarson T13A36).
- T₂ — Transceiver transformer (Thordarson T72A59).
- RFC₁ — 20 turns No. 24 enam., $\frac{1}{4}$ -inch diam., spaced diam. of wire.
- RFC₂ — U.h.f. r.f. choke (Ohmite Z-1).
- S₁ — Two-gang three-circuit two-position non-shorting switch, modified. See text. (Yaxley 1323L.)

sweated to a Johnson jack to fit snugly into the antenna socket.

The details of construction of the rest of the unit can be gathered from Figs. 2842 and 2843. It is advisable to gather together all of the parts before drilling any holes, so that one can be sure there will be room for everything. The combination A and B battery (Burgess 4TA60) is held in place by a piece of $\frac{1}{2}$ -inch brass angle at the top, by the modulation transformer on the side, and by cardboard stuffed in back when the back plate is put on. The microphone and C battery (two Burgess B3BPX in parallel) is held in place by a brass bracket which is fastened directly to the positive terminals.

No difficulty should be encountered in putting the unit in operation. The transmitter antenna coupling condenser, C₂, should be screwed up until the oscillator refuses to oscillate, from which point the condenser can be backed off a turn or two, with assurance that the coupling is adequate. The coil, L₁, should be adjusted so that the 112-Mc. band will fall at the high-capacity end of the tuning range of the condenser. It is not necessary to use a high-gain carbon microphone, since the $4\frac{1}{2}$ volts in the microphone circuit allows more than enough signal to get to the modulator, and it is not necessary to shout into the microphone even with a fairly insensitive unit. If any trouble is experienced with the receiver not "supering" over the range (as indicated by a strong hiss), different values of R₂ and C₇ should be tried.

Transmitters and Transceivers for the U.H.F.

Fig. 2843 — A close-up view of the sub-chassis shows the two arms of the antenna switch and the polystyrene lever arm running from the "send-receive" switch up through the slot to the flexible lead from the antenna post. The antenna switch is mounted towards the front of the sub-chassis; the tube sockets (which are ring-mounting) are located at the very rear of the sub-chassis.

The transmitter portion is at the right and the receiver at the left. The modulator tube socket is the center one.

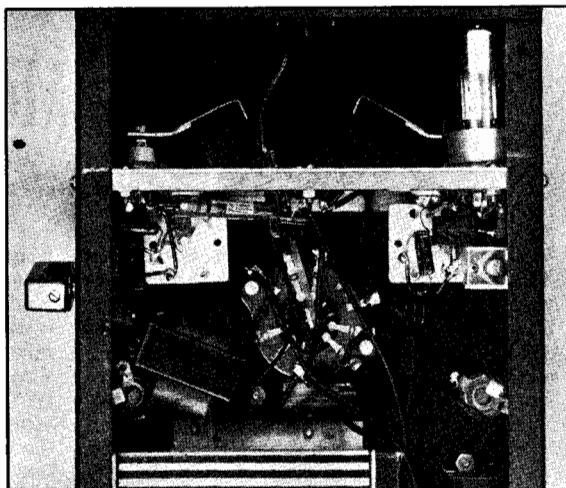

If the microphone is left in its jack when the unit is turned off, the send-receive switch should be set at "receive", otherwise the microphone battery will discharge through the microphone.

Bibliography

- ¹ Taylor, *QST*, Aug., 1939.
- ² Goodman, *QST*, Nov., 1940.
- ³ Jacobs, *QST*, April, 1940.
- ⁴ Chambers, *QST*, April, 1940.

Frequency Modulation

Principles — Transmitters — Receivers

UNTIL quite recently, amplitude modulation (variance of carrier amplitude in accordance with the audio frequencies while the frequency of the carrier remains constant) was considered the only practical type of modulation, and every effort was made towards reduction or elimination of the frequency modulation sometimes introduced in amplitude-modulation processes. However, it has been demonstrated that, with the proper type of receiver, frequency modulation can result in the reduction or elimination of man-made noise to a much greater degree than is possible with the more common type of modulation. Since all noise is an amplitude variation, a receiver that is insensitive to amplitude modulation will not be affected by noise. Such a type of receiver is used for the reception of frequency-modulated signals, and it results in virtually noise-free reception. Deliberate f.m. is allowed only in the 58.5- to 60-Mc. range and the higher-frequency amateur bands, and consequently it is a part of only the u.h.f. picture.

Principles

F.m. consists of varying the frequency of the carrier in accordance with the audio modulating frequencies at a rate proportional to the frequency of the modulating signal and by an amount proportional to the amplitude of the modulating signal. In other words, the higher audio frequencies will change the frequency of the carrier faster, and the louder audio signals will swing or deviate the carrier

frequency farther from the mean frequency. The mean or average frequency remains constant at all times; thus the signal deviation is equal on either side of the carrier frequency for any given amplitude. Linear modulation simply requires that the deviation be directly proportional to the amplitude and that the rate of deviation be directly proportional to the audio frequency. It is required by regulation that the signal amplitude and mean frequency remain constant in the 58.5- to 60-Mc. range and, for this reason, the 5-meter f.m. equipment is usually a bit more elaborate than that used on the higher frequencies.

Although f.m. signals can be received on an ordinary superregenerative or superheterodyne receiver by tuning off to one side of the carrier frequency, it is only by using a regular f.m. receiver that the noise-limiting properties can be obtained. An f.m. receiving system differs from an a.m. receiver in that, instead of the detector (or second detector in the case of a superheterodyne), it uses a limiter, to remove all traces of amplitude modulation, and a discriminator, to recover the audio modulation from the signal. The limiter is usually a high- μ tube used as a grid-leak-biased amplifier stage operating at low plate and screen voltage. When enough signal is applied to the grid, the rectified current through the grid leak biases the tube, and this in combination with the low plate and screen voltage causes the tube to saturate and become unresponsive to any amplitude changes above a certain level. This level is usually quite low compared to the level of the signal. However, in order for the limiter to work well, it is necessary that a fairly strong signal be applied to it, which requires that a good order of amplification be used ahead of the limiter. The discriminator is a variety of full-wave rectifier (see Fig. 2914), since opposite ends of the transformer secondary feed the two diode plates. However, the two diode cathodes are not connected together but tie across opposite ends of a high resistance, one end of which is grounded. The center tap of the transformer secondary is returned to the midpoint of the diode load resistor for a d.c. return and is also coupled to the "hot" end of the transformer primary through a small coupling condenser. Thus the voltage applied to the rectifier network can be

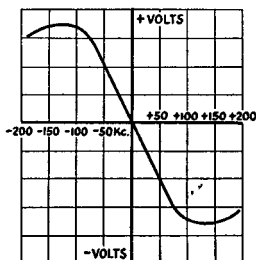

Fig. 2901 — The characteristic of the second detector of an f.m. receiver. The vertical axis represents the voltage developed across the load resistor as the frequency varies from the exact resonance frequency.

A detector with this characteristic would handle f.m. signals up to a band-width of about 150 kc. (over the linear portion of the curve).

Frequency Modulation

Fig. 2902 — This modulator-oscillator unit can work into practically any crystal-controlled 56-Mc. transmitter for frequency-modulated output. It contains a speech amplifier and power supply, so that no additional equipment is needed.

The oscillator coil is in the round shield can in the center. The coil in the left foreground is the buffer output circuit. Speech amplifier and modulator are at the right, with the power supply along the rear edge. A 7 by 11 chassis is used.

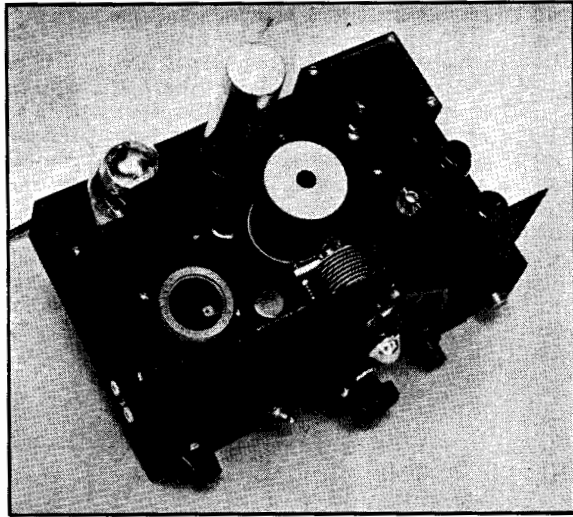

considered as consisting of two parts: that contributed by capacity coupling through the condenser and that induced by inductive coupling between the two windings. The voltage introduced by capacity coupling is in phase with the voltage across the primary of the transformer while the voltage induced by inductive coupling is always 180° out of phase with the voltage across the primary. At resonance, the current in the secondary will be in phase with the secondary voltage, since the secondary winding shows only resistance at this frequency, but at frequencies higher and lower than resonance the secondary will show inductive and capacitive reactance, respectively, and the current will lag and lead the voltage. The resultant rectified voltage developed across the load resistor can be drawn as in Fig. 2901, which might be considered the detection characteristic of the stage. Thus no voltage is developed across the load resistors at resonance, but as the frequency becomes higher than resonance a proportionate negative voltage appears across the resistor, and as the frequency becomes lower than resonance, a proportionate positive voltage appears across the load resistor. Hence the audio output is proportional to the frequency deviation and, for good detection, this characteristic should be linear over the pass band of the i.f. amplifier and symmetrical about the resonance frequency of the amplifier.

In the transmitter, the design is conventional except for the modulator circuit. Unlike a.m. systems, the modulator is a tube working as a variable inductance (or capacitance) connected across the tank circuit of a self-excited oscillator. Audio voltage fed to the modulator tube causes it to act as more or less inductance (or capacity, depending upon the way the tube is

connected) and thus varies the frequency of the oscillator. The output of the oscillator passes to the conventional doubler and amplifier stages.

The tube connected to work as a variable inductance, or **reactance modulator** (see Fig. 2903 — the 6L7 is the reactance modulator), has its control grid connected across a small capacity, C_{11} , which is in series with resistor R_{11} across the oscillator tank circuit. The current through R_{11} will be in phase with the voltage across the tank, but the voltage across C_{11} will be 90° behind the current, because of the property of a condenser in causing the voltage across it to be in quadrature with the current through it. The r.f. current in the modulator plate circuit will be in phase with the r.f. voltage on the grid, and consequently lags the current through C_{11} by 90° . This lagging current is drawn through the oscillator tank, and since causing a 90° lagging current is the property of an inductance, the modulator tube simulates an inductance connected in parallel with the tank inductance. The amplitude of the lagging current, and hence the effective value of the inductance, can be varied by changing the amplification through the tube. By varying the current at an a.f. rate, frequency modulation is obtained. Other variations of tube elements can be used, as will be seen in other reactance modulators to be described, but the principle is the same.

A reactance modulator can be checked for linearity by placing a low-range milliammeter in its plate circuit and noting whether or not the plate current flickers under modulation. If it does, it normally indicates that the audio signal is in excess of the bias of the modulator, and that the modulator should not be run at such a high signal level. The reactance modula-

The Radio Amateur's Handbook

tor is essentially a Class A amplifier, and the same general principles for linearity hold.

If the reactance modulator does not give enough deviation to the oscillator, the L/C ratio of the oscillator tank must be increased. The L/C ratio should not be increased past the point that allows the desired deviation to be obtained without distortion, because raising the L/C ratio is likely to decrease the inherent stability of the oscillator. A good figure of deviation for amateur f.m. is 15 kc. either side of the carrier frequency. This is easily obtained with the constants given for the equipment described in this chapter. (*Bib. 1*)

An F.M. Modulator-Oscillator Unit

If one already has a crystal-controlled 56-Mc. transmitter using amplitude modulation, it is a relatively simple matter to disconnect the modulator and substitute for the crystal-controlled oscillator the f.m. oscillator-modulator shown in Figs. 2902-2904. The r.f. output of the unit is intended to be fed through a link to a tuned circuit which substitutes for the crystal in the crystal oscillator. This tuned circuit is resonant at the same frequency as the output tank of the control unit, L_2C_3 in Fig. 2903, and is in fact identical with it in

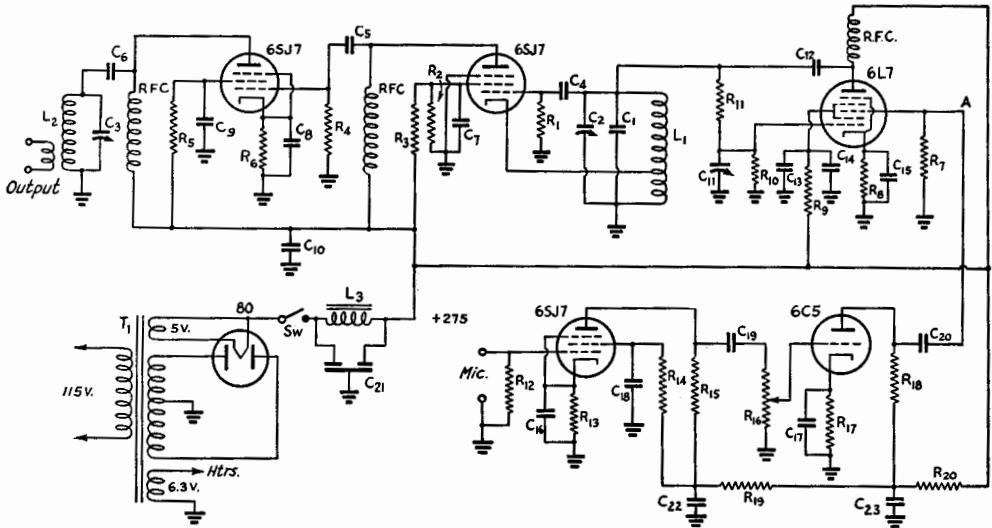

Fig. 2903 — Circuit diagram of the control unit for use with normally crystal-controlled transmitters.

- | | | |
|---|---|---|
| C ₁ — 150- μ fd. silvered mica for 7 Mc., 650 μ fd. for 3.5 Mc.; 1150 μ fd. for 1.75 Mc. | R ₁ — 0.1 megohm, 1-watt. | 3.5 Mc.: 11 turns No. 24 enam., length $\frac{3}{4}$ inch, diameter 1 inch, tapped 4th turn from ground. |
| C ₂ — 100- μ fd. variable (National SE-100). | R ₂ — 25,000 ohms, 1-watt. | 1.75 Mc.: 21 turns No. 24 enam., length 1 inch, diameter 1 inch, tapped 6th turn from ground. |
| C ₃ — 50- μ fd. variable (Hammarlund HF-50). | R _{3, R_{4, R₅} — 50,000 ohms, 1-watt.} | L ₂ — 14 Mc.: 10 turns No. 18. |
| C ₄ — 100- μ fd. mica. | R ₆ — 300 ohms, $\frac{1}{2}$ -watt. | 7 Mc.: 20 turns No. 18. |
| C ₅ — 250- μ fd. mica. | R ₇ — 0.5 megohm, $\frac{1}{2}$ -watt. | 3.5 Mc.: 40 turns No. 24. |
| C ₆ — 0.001- μ fd. mica. | R ₈ — 300 ohms, $\frac{1}{2}$ -watt. | 1.75 Mc.: 75 turns No. 26. |
| C _{7, C_{8, C_{9, C₁₀}} — 0.01-μfd. paper.} | R ₉ — 30,000 ohms, 1-watt. | All coils wound with enamelled wire on $1\frac{1}{2}$ -inch diameter forms (Hammarlund SWF-4). 1.75-Mc. coil close-wound; others spaced to a length of $1\frac{1}{2}$ inches. |
| C ₁₁ — 3-30- μ fd. compression trimmer (set full open). | R ₁₀ — 0.5 megohm, $\frac{1}{2}$ -watt. | Link 3 to 5 turns, not critical. |
| C ₁₂ — 250- μ fd. mica. | R ₁₁ — 50,000 ohms, 1-watt. | L ₃ — 10 henrys, 40 ma. |
| C ₁₃ — 0.01- μ fd. paper. | R ₁₂ — 5 megohms, $\frac{1}{2}$ -watt. | T ₁ — 250 volts at 40 ma.; 6.3 volts at 2 amp.; 5 volts at 2 amp. (Thordarson T13R11). |
| C ₁₄ — 8- μ fd. electrolytic, 450-volt. | R ₁₃ — 900 ohms, $\frac{1}{2}$ -watt. | Sw — S.p.a.t. toggle switch. |
| C ₁₅ — 0.01- μ fd. paper. | R ₁₄ — 1 megohm, $\frac{1}{2}$ -watt. | |
| C _{16, C₁₇} — 10- μ fd. 25-volt electrolytic. | R ₁₅ — 0.25 megohm, $\frac{1}{2}$ -watt. | |
| C ₁₈ — 0.1- μ fd. paper. | R ₁₆ — 0.5-megohm volume control. | |
| C _{19, C₂₀} — 0.01- μ fd. paper. | R ₁₇ — 2000 ohms, $\frac{1}{2}$ -watt. | |
| C ₂₁ — Dual 8- μ fd. electrolytic, 450-volt. | R ₁₈ — 50,000 ohms, $\frac{1}{2}$ -watt. | |
| C _{22, C₂₃} — 8- μ fd. electrolytic, 450-volt. | R ₁₉ — 0.25 megohm, $\frac{1}{2}$ -watt. | |
| | R ₂₀ — 0.15 megohm, 1-watt. | |
| | RFC — 2.5-mh. r.f. choke. | |
| | L ₁ — 7 Mc.: 10 turns No. 18 enamelled, length $\frac{3}{4}$ inch, diameter 1 inch, tapped 3rd turn from ground. | |

Note: Data for L_1 subject to individual trimming for proper frequency coverage. Adjust inductance by changing turn spacing to bring low frequency end of band near maximum capacity on C_2 . Coil specifications given apply to coil centered in round shield 2 inches in diameter and $2\frac{1}{2}$ inches high. The 3.5- and 7-Mc. coils will give full coverage of the 56-60-Mc. band with C_2 100 μ fd.; the 1.75-Mc. coil will cover approximately 57-60 Mc. with the same variable condenser.

Frequency Modulation

construction. In transmitters using triode or pentode crystal oscillators in which the tubes are not well screened, it is advisable to use the crystal oscillator tube as a doubler rather than as a straight amplifier. If the transmitter uses a 7-Mc. crystal oscillator, for instance, the output of the unit can be on 3.5 Mc. and the grid circuit of the ex-crystal tube tuned also to 3.5 Mc. This will avoid difficulty with self-oscillation in the ex-crystal tube. With a pentode oscillator it is possible to work straight through provided the grid tank substituted for the crystal is tuned well on the high-frequency side of resonance, but this procedure is not advisable since it may make the modulation non-linear. It is rather important that all circuits in the transmitter be tuned "on the nose" for best performance. Of course, if the crystal tube is a well-screened transmitting type it can be used as a straight amplifier.

With harmonic-type oscillators the input frequency can be the same as that of the crystal, since the output frequency of the crystal tube is already a harmonic. In the Tri-tet the cathode tank should be short-circuited; in the types using a cathode impedance to provide feedback

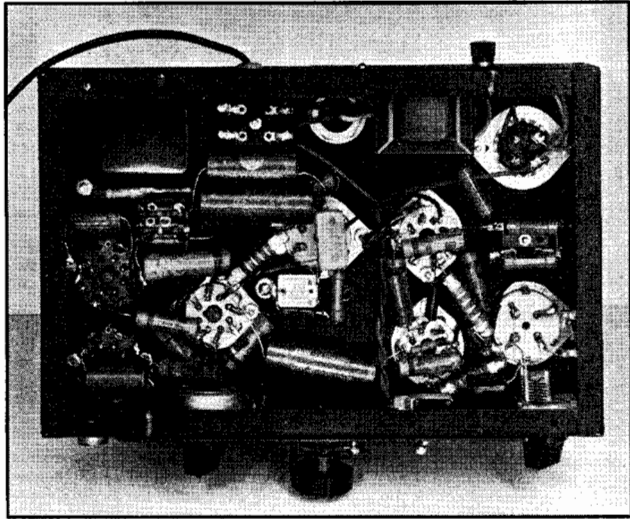

Fig. 2904 — In this bottom view of the unit, the r.f. section is at the right and the audio at the left. The oscillator socket is the one just to the right of the coil socket in the center.

this impedance also should be shorted. Care should be taken to avoid short-circuiting the grid bias, whether from a cathode resistor or grid leak. In the latter case this usually will mean that a blocking condenser (500 $\mu\text{fd.}$ or larger) should be connected between the "hot" end of the grid tank and the grid of the ex-crystal tube, with the grid leak (and choke) connected on the grid side of the condenser. Such a blocking condenser can be incorporated in the plug-in tank. The grid tank tuning condenser can be a small air padder mounted in the coil form.

Those who already have a suitable power supply and speech amplifier can omit the lower part of Fig. 2903 and build simply the oscillator, buffer and modulator. Transformer input to the modulator can be used in case the available speech amplifier happens to have a low-impedance output circuit. The transformer and gain control connect between ground and point "A" of Fig. 2903, R_7 being omitted. Any of the conventional methods may be used, in fact, to couple the modulator to an available speech amplifier, with one precaution — if a high-impedance connection is used the "hot" lead should be shielded to prevent hum pickup. (Bib. 2)

If a self-excited oscillator, electron-coupled or otherwise, is in use

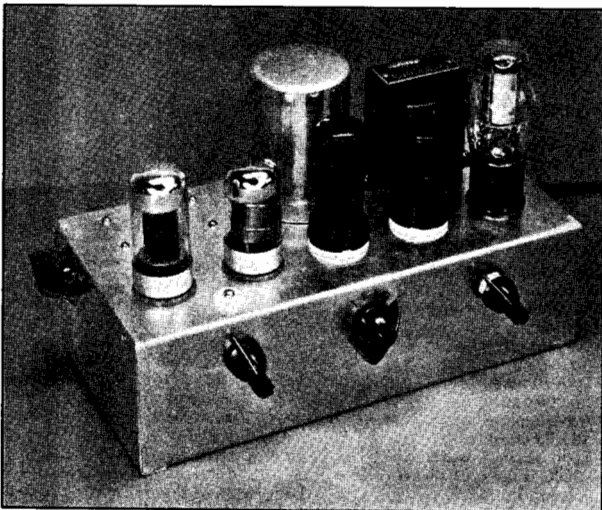

Fig. 2905 — The complete 56-Mc. f.m. transmitter has all of the r.f. components under the chassis with the exception of the oscillator grid coil, which is housed in the shield can in the rear center of the chassis. The tubes, from left to right, are 7C5 output amplifier, 7G7 doubler, 6F6 e.c.o., 6SA7 reactance modulator, and VR-150 voltage regulator.

The Radio Amateur's Handbook

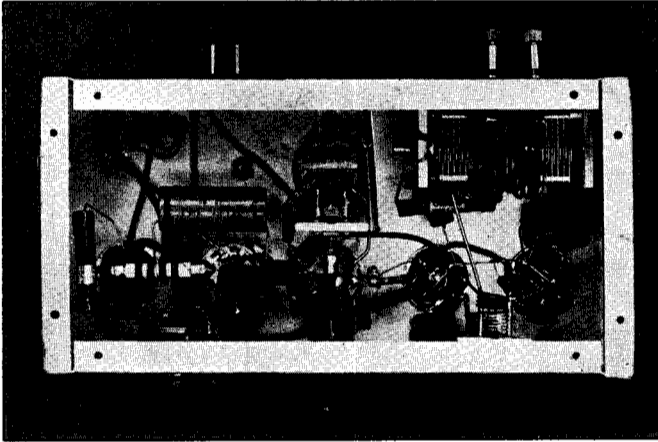

Fig. 2907 — A view underneath the chassis of the 56-Mc. f.m. transmitter shows the volume control at the left, the oscillator control at the center, the doubler tuning control at the right, and the final amplifier tuning control at the side. The microphone is connected to a connector on the left side of the chassis, and the four-prong plug and flexible wire connect to power supply and microphone battery respectively. Note the shield between the final tuning condenser and the oscillator tuning condenser, to reduce reaction between the two circuits, and the wire running from the doubler tuning condenser to near the final tank condenser which is used as a neutralizing condenser (N in Fig. 2906).

The output connects to the two binding posts mounted on a Victron strip.

in the present transmitter, a separate oscillator need not be built, and the reactance modulator

put amplifier. Used as an f.m. transmitter, the entire unit uses 300 volts at about 90 ma., mak-

can be connected directly across the tank circuit of the oscillator. If the oscillator uses too high a C/L ratio, not enough deviation may be obtained without distortion, and it is advisable to revise the L/C ratio in the oscillator to be more comparable to those given in Fig. 2903.

A Complete 56-Mc. F.M. Transmitter

The transmitter shown in Figs. 2905-2907 will yield a carrier of approximately 7 watts on 56 Mc., using a power supply of 300 volts rating. A reactance modulator is incorporated in the unit, and if it is desired to use amplitude modulation the gain control on the reactance modulator should be set at zero and the necessary 6 watts of audio connected in series to the plate and screen lead of the 7C5 out-

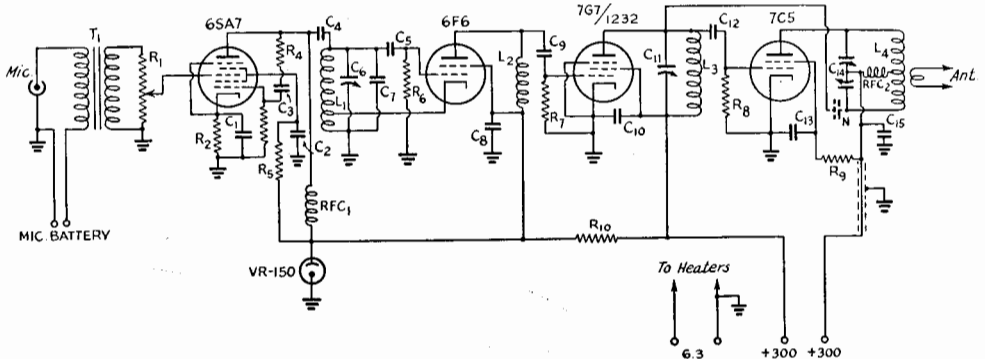

Fig. 2906 — Wiring diagram of the 56-Mc. f.m. transmitter.

- C₁ — 0.01- μ fd., 400-volt paper.
- C₂ — 8- μ fd. 450-volt electrolytic and 0.005- μ fd. mica in parallel.
- C₃ — 0.001- μ fd. mica.
- C₄ — 500- μ fd. mica.
- C₅, C₉, C₁₂ — 100- μ fd. mica.
- C₆ — 15- μ fd. midget variable (Hammarlund HF-15).
- C₇ — 25- μ fd. silvered mica (Sprague).
- C₈, C₁₀, C₁₈ — 0.005- μ fd. mica.
- C₁₁ — 35- μ fd. midget variable (Hammarlund HF-35).
- C₁₄ — 35 μ fd. per section midget split stator (Cardwell ER-35-AD).
- C₁₅ — Two 500- μ fd. mica, one at each end of rotor.

- N — Neutralizing condenser, see text.
 - R₁ — 100,000-ohm volume control.
 - R₂ — 750 ohms.
 - R₃ — 0.25 megohm.
 - R₄ — 50,000 ohms.
 - R₅ — 5000 ohms.
 - R₆ — 25,000 ohms.
 - R₇ — 0.1 megohm.
 - R₈ — 75,000 ohms.
 - R₉ — 5000 ohms, 1-watt.
 - R₁₀ — 3000 ohms, 10-watt wire-wound.
- All resistors $\frac{1}{2}$ -watt unless otherwise mentioned.
- RFC₁ — 2.5-mh. r.f. choke.
 - RFC₂ — U.h.f. r.f. choke (Ohmite Z-1).
 - T₁ — Microphone transformer

- (Thordarson T58A37).
- L₁ — 10 $\frac{1}{2}$ turns No. 20 enam. spaced to occupy 1 inch on 1-inch diam. form, cathode tap $2\frac{1}{2}$ turns up. Plugged into socket on chassis.
- L₂ — 14 turns No. 20 enam. spaced to occupy $1\frac{1}{2}$ inches, with diam. of $\frac{9}{16}$ inch, self-supporting (see text).
- L₃ — 4 turns No. 20 enam., $\frac{1}{2}$ -inch diam. and $\frac{1}{4}$ -inch long.
- L₄ — 6 turns No. 14 enam., $\frac{3}{4}$ -inch inside diam., wound to occupy 1-inch length, with $\frac{3}{8}$ -inch gap in center to take the swinging link of 2 turns No. 14 enam., same diam.

Frequency Modulation

ing it ideal to run from a vibrator pack for portable/mobile work.

A single-button carbon microphone is transformer-coupled to the 6SA7 reactance modulator which is connected across the tank circuit of the 6F6 e.c.o. A VR-150 stabilizes the voltage across the oscillator and modulator and aids materially in keeping the mean frequency constant. The grid circuit of the e.c.o. tunes from 14 to 15 Mc. with a slight margin at either end of the tuning range, and the plate circuit of the e.c.o. is tuned to 28 Mc. by using a self-resonant coil which is adjusted for maximum output by squeezing the turns together or pulling them apart. Once adjusted, it need not be touched for any tuning conditions. The 28-Mc. output of the e.c.o. drives a 7G7/1232 doubler to 56 Mc., which in turn drives the output amplifier. With a 300-volt supply, the final grid current should run about 0.6 ma. under load for linear amplitude modulation. If f.m. is used exclusively, the grid current can run lower with no harmful effect other than a slight decrease in output of the amplifier. The 7C5 final amplifier is plate neutralized by running a stiff wire from the plate side of the doubler tuning condenser over near the open side of the final amplifier split-stator tuning condenser. The capacity from this wire to the stator of the condenser is sufficient to neutralize the final amplifier, and it is adjusted by snipping off the wire a small bit at a time until the plate-tank tuning shows no reaction on the grid current (with plate and screen voltage off).

No difficulty should be encountered in adjusting the transmitter other than spotting the e.c.o. coils to the proper frequencies. The grid coil should be adjusted to the proper range with the reactance modulator tube in the circuit, and the range can be varied by pushing the turns together or spreading them apart, while checking the frequency on a calibrated receiver. The e.c.o. plate coil can best be adjusted by reading grid current to the final amplifier (by cutting in a 0-1 milliammeter between R_3 and ground) and adjusting L_2 until the grid current is a maximum with the oscillator set at 14.5 Mc.

The plate current of the final amplifier will run around 45 ma. when the stage is properly loaded. The loading is varied by changing the position of the "swinging link" fastened to the output binding posts.

When using f.m., the amount of

deviation is controlled by the setting of the gain control, R_1 . With the gain control wide open, the deviation is over 30 kc. on 58.5 Mc., which is more than adequate for all purposes. When the receiving station does not have a regular f.m. receiver, the signal can be received on a conventional receiver by reducing the deviation at the transmitting end and tuning the signal off to one side of resonance at the receiving end.

The power lead from the power supply plug to the final amplifier was shielded because it showed some traces of r.f. All r.f. should be kept out of the power supply in a rig like this where the oscillator is self-excited, because it is likely to roughen the note. When properly adjusted, the signal should be a very good T9. If it is still rough with the reactance modulator tube out of its socket, the trouble is in the e.c.o.; if it is rough with the modulator tube in its socket and the volume control set at zero, the trouble is in the modulator.

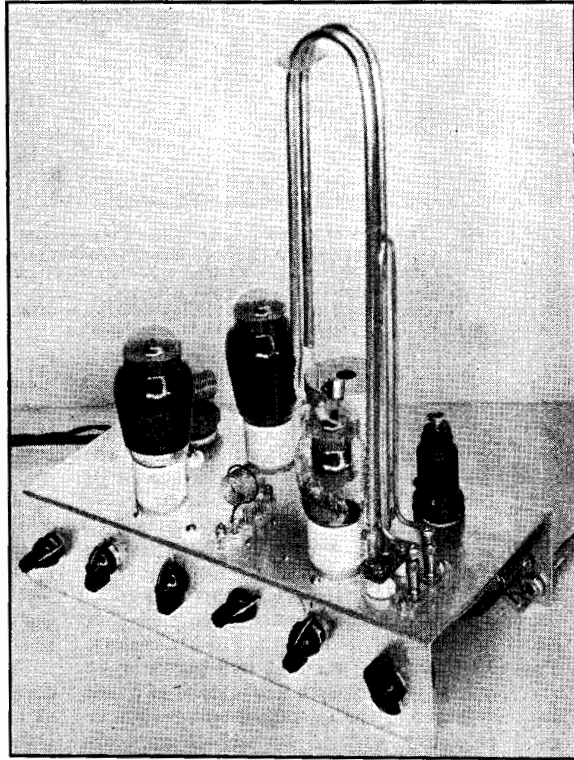

Fig. 2908 — A complete 112-Mc. f.m. transmitter which, with a 300-volt power supply, gives 6 watts output.

A quarter-wavelength line is used for the 112-Mc. tank, and the load is coupled in through the pick-up loop. Controls, from left to right, are meter switch, oscillator plate tuning, doubler plate tuning, tripler grid tuning, oscillator tuning and audio gain. The microphone connector can be seen at the right rear of the chassis.

The Radio Amateur's Handbook

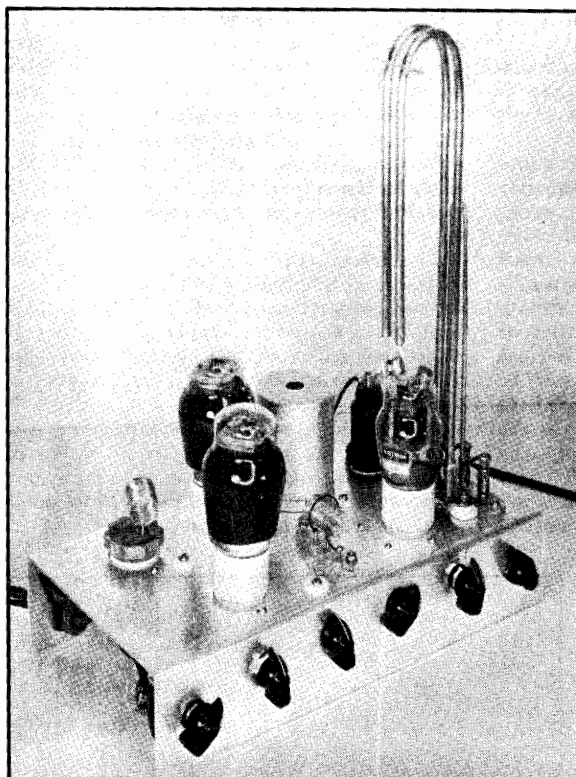

Fig. 2909 — This view of the transmitter shows the construction of the coils. The coil in the rear left-hand corner is the oscillator plate coil; the coil in the center front is the tripler grid coil, mounted on Victron bushings. The oscillator grid coil is mounted inside the shield can. The metal tube at the right of the shield can is the 6L7 modulator; the tube to the left of the can is the oscillator.

A 112-Mc. F.M. Transmitter

Although the transmitter just described can be used to drive a doubler and amplifier to 112 Mc. (see Figs. 2816-2819), a different approach is made in the transmitter shown in Figs. 2908-2911. The e.c.o. working on 9.33-9.67 Mc. and doubling in the plate circuit to 18.66-19.33 Mc. is conventional, as is the doubler which follows it and gives output from 37.33 to 38.66 Mc. However, this energy is used to drive an RK34 connected in push-pull which triples to the 112- to 116-Mc. range. The use of the balanced push-pull tripler stage and a quarter-wavelength line instead of a coil and condenser in the output circuit results in good efficiency and an output of approximately 6 watts on 112 Mc. The reactance modulator across the grid circuit of the e.c.o. is conventional.

A meter switch is provided for metering the oscillator plate circuit, doubler grid circuit, doubler plate and screen circuit, tripler grid circuit and tripler plate circuit. None of the cir-

cuits takes over 100 ma., and that range of meter is suggested.

The transmitter is built on a chassis of $\frac{1}{8}$ -inch aluminum, bent to form a "U" with $2\frac{1}{2}$ -inch sides. The top of the chassis measures 6 by 12 inches. Bending the sides gives the chassis sufficient rigidity, and no additional bracing is required even though the oscillator is self-excited. Reference to the photographs will give a clear idea of the distribution of parts, and no lengthy description is necessary. The oscillator tuning condenser C_1 is fastened directly to the chassis, and condensers C_2 and C_3 are mounted on National XS-6 lead-through bushings which support the condensers but insulate them from the chassis. To retain short leads in the oscillator and still make the panel controls symmetrical, it was necessary to offset the extension shaft controlling C_1 , but one of the new Millen 39001 flexible couplings does a good job of turning the corner without back-lash. Condenser C_4 is mounted on the two end-plate spacing bars and, fortunately, lines up with the other shafts. Panel bushings are used on the two extension shafts to keep the controls rigid.

The oscillator coil is wound on a 1-inch diameter bakelite form (Millen 45000 or National XR-2) and is supported above the chassis by a half-inch brass sleeve over the mounting screw. The shield for the oscillator coil was made by cutting down an old straight-sided, 2-inch diameter tube shield. The oscillator plate coil, L_2 , is self-supporting and is mounted on the base of an old coil form which has been cut off at the bottom and plugs into a tube socket. The doubler plate coil, L_3 , is also self-supporting and is mounted directly on the tuning condenser, while the tripler grid coil, L_4 , and link are self-supporting and mount on the National Victron type TPB bushings. They can be soldered directly to the ends of the posts instead of threading the support and using nuts as shown in the photographs.

The final tank circuit is made of quarter-inch copper tubing spaced $\frac{1}{4}$ inch. It is supported at the base by a copper strap in which two holes have been drilled to take the tubing and the tubing has been soldered in. If one soldering iron won't furnish enough heat for the job, borrow another and run them both on the work. The tubing should first be straightened, and then cleaned with polish. After the tubing has been soldered to the strap, two National metal-tube grid caps can be run down the tub-

Frequency Modulation

ing to the copper strap and soldered together when in position near the strap so that their spacing will be correct. The tubing can then be bent over in a loop so that the ends will come down near the plate caps of the RK-34. The copper base strap at the bottom of the tank is supported by bolting it to two feed-through bushings. The grid caps used to connect to the RK-34 are connected to the end of the tank by inch lengths of flexible copper braid soldered to the grid caps and the copper tubing. The flexible connection is to be preferred to a more rigid one in case of expansion or other strains on the RK-34.

The hairpin coupling loop is made of $\frac{1}{8}$ -inch copper tubing bent to the proper shape and soldered to two banana plugs which fit into jack top binding posts such as the National FWA. The binding posts are mounted on a Victron strip and, besides affording a support for the coupling loop, make convenient terminals for the antenna wires or link line to a following stage. Coupling is adjusted by bending the loop away or towards the tank line until the proper loading is obtained.

One side of the heaters of the tubes is grounded to the chassis. The power supply leads are brought out at the rear of the set

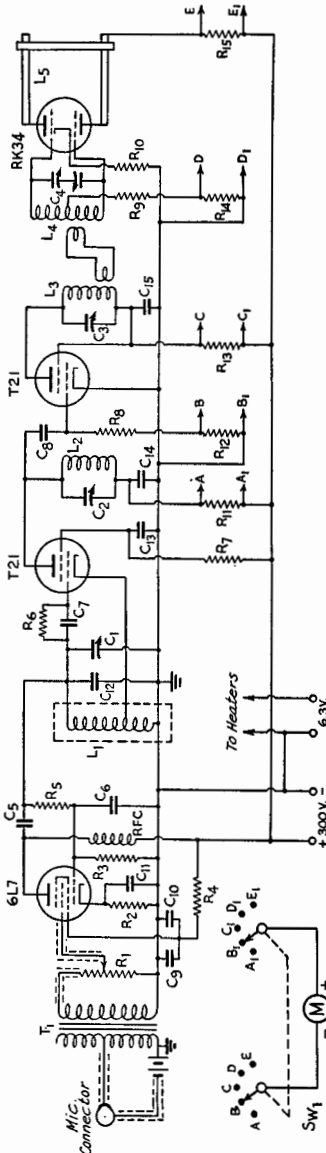

Fig. 2910 — Wiring diagram of the complete 112-Mc. f.m. transmitter.

- C₁ — 50- μ fd. midget variable condenser (Hammarlund HF-50).
- C₂ — 15- μ fd. midget variable condenser (Hammarlund HF-15).
- C₃ — 15- μ fd. double-spaced midget variable (Hammarlund HF-15-X).
- C₄ — 25- μ fd. each section dual midget variable (Cardwell ER-25-AD).
- C₅ — 250- μ fd. postage-stamp mica.
- C₆ — 3- μ fd. (National M30 with screw out. Mounted on brass pillar.)
- C₇, C₈ — 100- μ fd. postage-stamp mica.
- C₉ — 8- μ fd., 450-volt electrolytic.
- C₁₀, C₁₁ — 0.01- μ fd., 400-volt paper.
- C₁₂ — 150- μ fd. silver-mica condenser (Sickles Silvercap).
- C₁₃, C₁₄, C₁₅ — 0.002- μ fd. postage-stamp mica.
- R₁ — $\frac{1}{2}$ -megohm volume control.
- R₂ — 300 ohms, $\frac{1}{2}$ -watt.
- R₃ — $\frac{1}{2}$ -megohm, $\frac{1}{2}$ -watt.
- R₄ — 30,000 ohms.
- R₅ — 45,000 ohms.
- R₆ — 150,000 ohms.
- R₇ — 12,000 ohms.
- R₈ — 60,000 ohms.
- R₉ — 25,000 ohms, 10-watt wire-wound.
- R₁₀ — 500 ohms, 10-watt wire-wound.
- R₁₁, R₁₂, R₁₃, R₁₄ — 25 ohms, $\frac{1}{2}$ -watt. (Resistors 1-watt unless otherwise mentioned.)
- SW₁ — 2-circuit, 5-position rotary switch.
- T₁ — Double-button microphone transformer with only half the primary winding used (UTC S-6).
- L₁ — 8 $\frac{1}{2}$ turns No. 18, wound on 1-inch diameter form and evenly spaced to occupy 1-inch winding length. Cathode tap 2 $\frac{1}{4}$ turns from ground end.
- L₂ — 13 turns No. 18, wound self-supporting to have $\frac{3}{4}$ -inch diameter and spaced to occupy 1-inch winding length.
- L₃ — 7 turns No. 18, wound self-supporting to have $\frac{3}{8}$ -inch diameter and spaced to occupy $\frac{1}{2}$ -inch winding length.
- L₄ — 10 turns No. 18, wound self-supporting to have $\frac{3}{4}$ -inch diameter and spaced to occupy $\frac{7}{8}$ -inch winding length.
- L₅ — Two 23-inch lengths of $\frac{1}{4}$ -inch copper tubing spaced $\frac{1}{4}$ inch. The tubing is bent to form a half loop 2 inches wide. Coupling loop is of $\frac{1}{8}$ -inch diameter tubing, and is bent in form of hairpin extending up along L₅ for 7 inches. The coupling loops between L₃ and L₄ are single turns of No. 18.

The Radio Amateur's Handbook

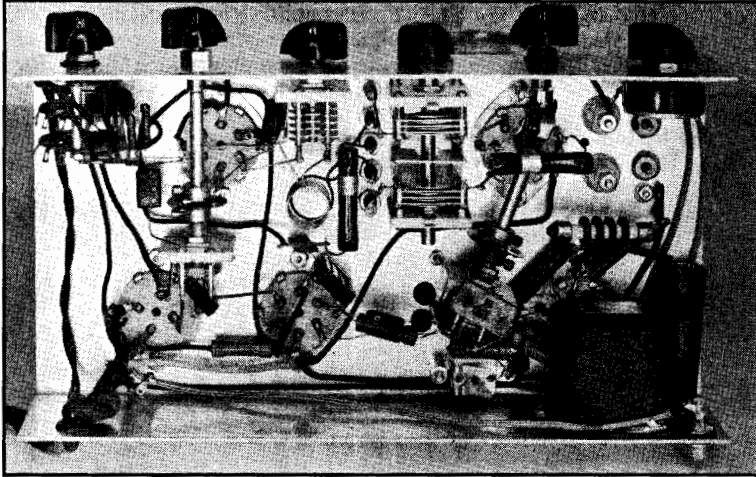

Fig. 2911 — A view underneath the chassis shows the location of parts. The microphone transformer is at the lower right, right next to the microphone connector. The small 3- μ fd. condenser used in the modulator can be seen to the left of the transformer, and directly above is the oscillator tuning condenser. The power cable runs out the back of the set at the lower left-hand corner; the twisted pair taken out the same hole goes to the meter.

through a rubber bushing — one wire for *B* minus and the grounded side of the heaters, a second for *B* plus and a third for the other side of the heaters. The fourth wire of the cable goes to the microphone battery, if a carbon microphone is used. A twisted pair goes to the meter. The leads from the microphone jack and from the volume control to grid and transformer are shielded to avoid any r.f. pick-up. The $\frac{1}{2}$ -watt resistors used in the metering circuits are mounted directly on the two-gang, five-position switch used for meter switching.

If the coil dimensions have been followed, no trouble should be experienced in adjusting the frequency range of the transmitter. The 6L7 and two T21's should be placed in their sockets and a power supply giving about 250 volts should be connected to the set. A 300-volt supply could be used, but it is well to adjust the coils at a lower voltage. An all-wave receiver is quite handy for checking the frequency of the transmitter and will save considerable time in adjusting the circuits. When the power is applied and the meter switch set to read oscillator plate current, a dip should show as the oscillator plate circuit is tuned through resonance, indicating oscillation. The all-wave receiver should be tuned to 9.5 Mc. and it should be possible to pick up the signal by tuning the grid circuit of the e.c.o. When it has been ascertained that the grid circuit will tune the range 9.3 to 9.7 Mc., the oscillator plate circuit range should be checked by tuning for a dip in current over this range. The T21 doubler should be in the socket at this time because the input capacity is high, and if the coil is adjusted with the following tube out of its socket, it will be found that the circuit will not tune to resonance when the doubler tube is plugged in.

When the oscillator coils have been adjusted

to cover their proper ranges, the meter should be switched to the doubler plate circuit and resonance checked here. Then, with the RK-34 in the socket but with the plate-voltage wire disconnected at the base of the plate tank, the RK-34 grid circuit should be checked for resonance by watching the RK-34 grid current. It will be found that the T21 plate circuits tune broadly but the RK-34 grid circuit tunes quite sharply. When grid current is obtained in the RK-34 (of the order of 10-12 ma. with 250 volts on the T21's), plate voltage can be applied to the RK-34 and the slider moved up and down until the RK-34 plate current dips sharply. The slider has plate voltage on it, so move it with a small piece of wood or some other insulating material and keep one hand in your pocket. With the oscillator on 9.5 Mc. and the other circuits tuned to the proper harmonics, the resonance dip should be obtained with the slider about one inch from the bottom. Any great discrepancy from this indicates that the wrong harmonic has been picked up somewhere along the line, but no serious trouble should be encountered if the coil data have been followed. The cathode resistor prevents the plate current from running too high in the off-resonance condition and should not be omitted from the circuit.

When all circuits have been found to resonate, the 300 volts can be applied to the set and, if everything is working properly, you should run about 100 ma. screen and plate current on the T21 doubler, and 12 to 15 ma. grid current on the tripler and, with no load, the tripler plate current should be about 20 ma. A small dial lamp connected to the coupling loop should light up brilliantly. It was found that the final could be coupled up to about 60 ma. plate current before the output refused to increase with increased loading, but

Frequency Modulation

at this input the output was about 6 watts, indicating excellent efficiency for the tripler at this frequency. Loadings will change the tuning of the final tank slightly.

When the rig is putting out well, it is only necessary to connect a single-button microphone to the connector and put the microphone batteries in the circuit. If a lower-output microphone is used, a stage of amplification will be required, and the output of the amplifier can be coupled to the modulator through a 200- or 500-ohm line. Listening to the signal on as high a harmonic as the all-wave receiver will go should yield a signal that, when modulated, is just not quite understandable but which obviously is being spread out quite a bit under modulation. With no modulation, a T9 signal should result, and if any ripple is present it must be eliminated or else there will be bad hum on the carrier. More filter can be added to the power supply and a 0.1- μ f. condenser connected between oscillator heater and ground. (*Bib. 3*)

Receivers

As pointed out earlier in this chapter, an f.m. receiving system differs from an a.m. one in that the pass band is wider and a limiter and discriminator are used instead of a second detector. The front end of an f.m. receiver is conventional, and any u.h.f. converter can be used to feed an f.m. i.f. amplifier. A u.h.f. converter is described in Chapter Twenty-Seven (Figs. 2701-2706). The f.m. i.f. amplifier can be either the i.f. amplifier of a broadcast f.m. receiver (of which there are several available on the market) or it can be readily built by the amateur. If the i.f. system of the f.m. broadcast receiver is used, the i.f. frequency should be learned so that the output of the converter can be tuned to this frequency and coupled to the grid of the mixer tube in the receiver.

The i.f. amplifier shown in Figs. 2912-2914 is a broad-band affair working on 5 Mc. that can be used for either f.m. or a.m. reception by switching the grid lead of the first audio tube from across the discriminator load (for f.m. reception) to the limiter grid resistor for a.m. reception. Because a wider-band amplifier is required for f.m. than for a.m., the amplifier is not so selective as it could be on a.m. signals, but this presents no particular difficulty at the present time, with QRM presenting a problem only in rare instances. Used with the converter described (or any converter capable of working into a 5-Mc. am-

plifier), the system can be used for the reception of a.m. and f.m. signals in the 43-Mc. band, a.m. and f.m. amateur signals in the 56-Mc. band, and f.m. and a.m. signals in the 112-Mc. band. If you can get the fellows you work on 112 Mc. who are using modulated oscillators to cut down their modulation (and thus bring their frequency deviation down to a reasonable range), the system makes a grand receiver for the reception of modulated oscillators, and even the smallest transceiver will sound many times better and save audio power as well.

As can be seen from an examination of Fig. 2914, two stages of high-gain amplification using Type 1852 tubes are unconventional only in that resistors are used across the transformer windings, to widen the pass band, and no gain control is included. No control of gain is required because it is always desirable to work the stages preceding the limiter at their highest level. The limiter stage uses a 6SJ7, with provision through R_{18} to control the plate and screen voltage to set the limiting action to meet operating conditions. The use of a grid leak and condenser, R_{16} , and C_7 , and low screen and plate voltage allows the tube to saturate quickly, even at low signal levels, and the tube wipes off any amplitude modulation (including noise) and passes only frequency modulation. For a.m. reception, the audio system is switched, by Sw_1 , on to the grid leak, R_{16} , and the grid and cathode of the tube are used as a diode rectifier to feed the audio sys-

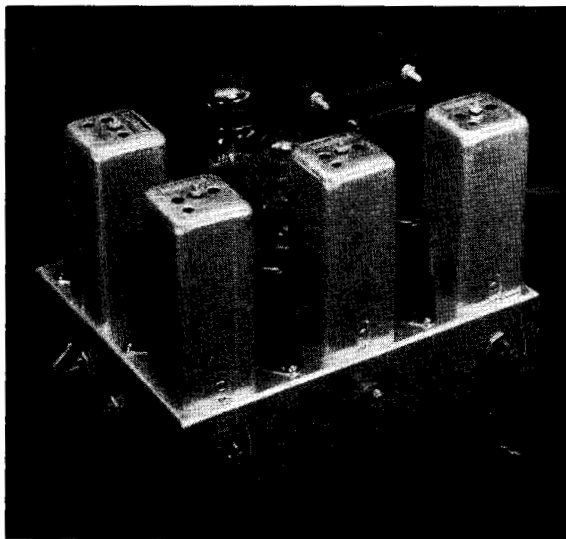

Fig. 2912 — The 5-Mc. f.m./a.m. amplifier is built, complete with power supply, on a 7-inch by 9-inch by 2-inch chassis. Controls on the front, from left to right, are audio volume control, B-plus switch and limiter control. The switch on the side is for changing from f.m. to a.m. and back, and the jack allows a meter to be plugged in to read limiter current.

The Radio Amateur's Handbook

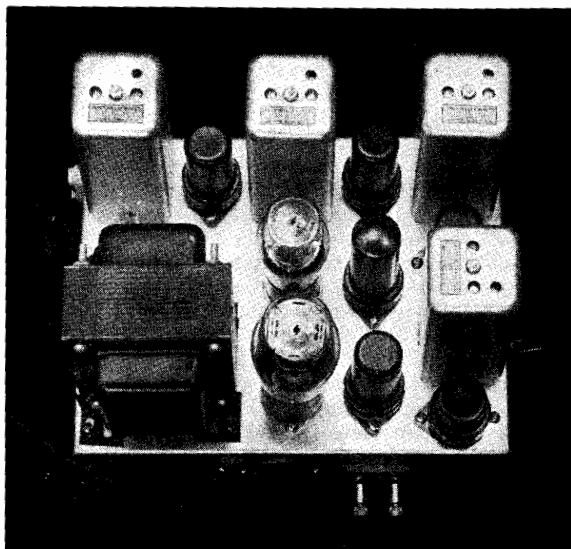

Fig. 2913 — A view of the top shows the arrangement of parts. Along the rear, from left to right, are the input transformer, first 1852, interstage transformer, second 1852 and interstage transformer. The second row of tubes, from right to left, are the 6SJ7 limiter, 6F6 audio output and VR-150 voltage regulator. The transformer at the right front is the discriminator transformer, the 6H6 detector is in front of it. The tube to the left of the 6H6 is the 6SF5 first audio. Output terminals, converter power supply socket, and 110-volt line cord can be seen.

tem. The jack, *J*, in series with the grid leak, is used for plugging in a low-range milliammeter so that the limiter current can be read. The limiter current indication is invaluable in aligning the amplifier, and the meter can be used as a tuning meter during operation.

The discriminator circuit uses a 6H6 double diode in the conventional circuit. Audio from the discriminator (or from the limiter stage, in a.m. reception) is fed through the volume control, R_{25} , into a two-stage audio amplifier using a 6SF5 and 6F6 output pentode. The resistor R_{11} and the condenser C_{12} in the input of the audio circuit serve as a combined r.f. filter and a compensating network to attenuate the higher audio frequencies. It is necessary to include some sort of compensation when listening to 43-Mc. broadcast stations, since nearly all of them use "pre-distortion" (accented higher frequencies). A 0.01- μ fd paper condenser can be added across the output terminals for further compensation, if it is considered necessary.

The power supply uses a two-section filter, and an outlet socket is provided so that the converter power cable can be plugged in. A VR-150 regulator tube is used to regulate the voltage on the converter, making for additional stability of the converter with changes in line voltage. The addition of the regulator tube adds little in the way of expense to the amplifier and, although not absolutely necessary,

is a nice refinement. If desired, it can be left out by simply erasing it from the circuit.

The amplifier is built on a 7-inch by 9-inch by 2-inch chassis. Reference to Figs. 2912 and 2913 will show the location of the parts on the chassis to be straightforward and follow in logical order. After all of the holes have been drilled for the various components, the sockets and the transformer should be fastened in place on the chassis, leaving off the variable resistors, switches, binding posts, jack and chokes until after most of the wiring has been done.

If the amplifier is to be built to use low-impedance input coupling, the first i.f. transformer must be modified. A link winding is made by first winding a short strip of half-inch wide paper for several turns over the cardboard tubing used as a form in the i.f. transformer. Eleven turns of No. 30 d.s.c. wire are then close-wound flat around the center of the paper ring. Holding the wire in place with a finger, paint the coil with Duco cement to secure the turns in place. When the cement has dried, it should be possible to slip the coil off the cardboard

form. The plate and B-plus wires are removed from the trimmer condenser in the transformer, and the wires from the plate coil to the trimmer condenser are disconnected. By unwinding and cutting off a turn or two of paper from the inside of the paper ring, the 11-turn coil can now be slipped easily over the grid coil and fastened in position so that it covers the ground end of the grid coil. A piece of paper should be slipped between the grid coil and the ground lead from the grid coil, to avoid any possibility of this lead shorting against the turns of the coil when the paper ring is slipped in place. The two ends of the link coil are brought out the bottom of the transformer can and later fastened to the input terminals of the set.

It is, of course, possible to use the transformer as is, by running the plate lead of the transformer to the plate of the mixer tube in the converter, but this makes it less convenient to use the converter with sharper i.f. amplifiers, since it would require soldering and unsoldering wires in the converter each time the change was made. Further, the long lead to the mixer tube would increase the chances for stray pickup of signals in the vicinity of 5 Mc.

The usual procedure is followed in wiring the amplifier. One side of the heaters is grounded. By-pass condensers are mounted and grounded as close to the associated tube as possible. The

Frequency Modulation

screen by-pass condensers, C_1 , C_4 and C_8 , are mounted across the sockets so that they act as a partial shield between the plate and grid of the tube, as is the custom with single-ended tubes. Tie-points are used wherever they are needed for mounting resistors and condensers. It is recommended that the 1852, 6SJ7 and 6H6 stages be wired first, so that the leads carrying r.f. can be made as short and direct as possible. After that, the rest of the leads can be filled in wherever convenient. The wires from the audio volume control, R_{25} , are shielded by running them over in a single piece of flexible copper braid. Whenever convenient, spare pins on sockets were used to support resistors, condensers, etc.

If the parts list is duplicated, it will be found that the two variable resistors mounted on the front of the chassis will not clear the spade bolts projecting down from the i.f. transformers above, and this is easily remedied by cutting off $\frac{1}{8}$ inch of the spade bolts before mounting the transformers in place. Also, in order to make room for the 6SF5 cathode by-pass condenser, C_{17} , some of the binding post strip for

the output terminals had to be filed off. A simpler way would be to mount the binding-post strip nearer the bottom of the chassis. The input terminals, a Millen crystal holder, are mounted on the outside of the chassis so that they will clear the limiter control. A handy connector for plugging into this input terminal can be made from an old 5-prong tube base or coil form, by sawing across the base and removing the two correctly-spaced pins and their supporting strip of bakelite.

If you have a source of 5-Mc. signal, such as a signal generator, aligning the amplifier is a very easy matter. If you don't already have the source available, a simple e.c.o. can be built with the grid circuit on 2.5 Mc. and the plate on 5 Mc. using an ordinary receiving pentode like the 6K7. Or, if you already have the converter, tune your regular receiver to 5 Mc., couple in the converter and tune in a steady signal, such as a harmonic from your transmitter or some other strong signal. The converter output can now be transferred to the f.m./a.m. i.f. and the transformers aligned. This is done by plugging in a 0-1 ma. meter in the jack, J ,

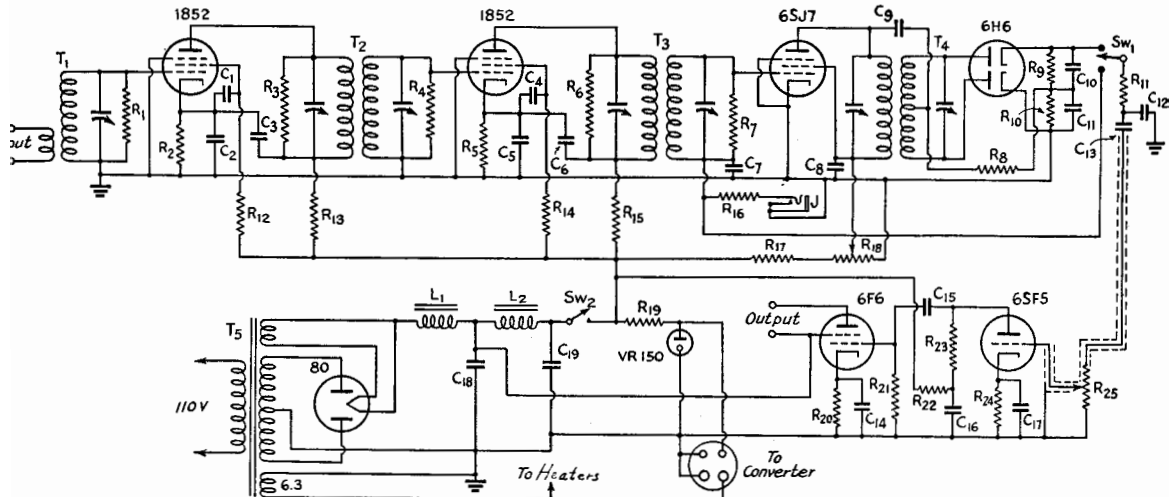

Fig. 2914 — Wiring diagram of the 5-Mc. f.m./a.m. amplifier.

- C_1 , C_2 , C_3 , C_4 , C_5 , C_6 , C_8 , C_{13} , C_{15} — 0.01- μ fd., 600-volt paper.
- C_7 , C_{10} , C_{11} — 100- μ fd. midget mica.
- C_9 — 50- μ fd. midget mica.
- C_{12} — 0.001- μ fd. midget mica.
- C_{14} , C_{17} — 10- μ fd., 25-volt electrolytic.
- C_{16} , C_{18} , C_{19} — 16- μ fd., 450-volt electrolytic.
- R_1 , R_4 — 55,000 ohms. R_2 — 200 ohms.
- R_3 , R_6 — 50,000 ohms. R_5 — 300 ohms.
- R_7 — 40,000 ohms. R_8 , R_{11} , R_{22} — 75,000 ohms.

- R_9 , R_{10} , R_{16} — 150,000 ohms. R_{12} , R_{14} — 60,000 ohms.
- R_{13} , R_{15} — 100 ohms.
- R_{17} — 25,000 ohms, 10-watt wire-wound (Ohmite).
- R_{18} — 3000-ohm wire-wound potentiometer.
- R_{19} — 5000 ohms, 10-watt wire-wound (Ohmite).
- R_{20} — 500 ohms, 1-watt.
- R_{21} , R_{23} — 250,000 ohms.
- R_{24} — 5000 ohms.
- R_{25} — 500,000-ohm volume control.
- T_1 — 5-Mc. input transformer, modified. See text (Millen 67503).
- T_2 , T_3 — 5-Mc. interstage Transformer (Millen 67503).

- T_4 — 5-Mc. discriminator transformer (Millen 67504).
- T_5 — 700-volt, 90-ma. transformer with 6.3- and 5-volt windings.
- L_1 — 9-henry, 85-ma. choke (Thordarson T-13C29).
- L_2 — 10-henry, 65-ma. choke (Thordarson T-13C28).
- Sw_1 — Selector switch, only two positions used (Yaxley 32112-J).
- Sw_2 — On-off switch, s.p.s.t. toggle. J — Closed-circuit jack.

All condensers are Mallory; all resistors are Centralab of $\frac{1}{2}$ -watt rating unless otherwise noted.

The Radio Amateur's Handbook

and tuning the trimmers of the transformers for maximum current. You may have to hunt around a bit before the meter shows any indication, but once it starts to read the rest is easy. With a variable-frequency signal source, the signal is swung back and forth until some indication is obtained and then the amplifier alignment is completed. The exact frequency of alignment is unimportant as long as every stage can be tuned *through* resonance, which means that each trimmer can be adjusted through a maximum reading of the tuning meter. With the resistors across the circuits, it will be found that the transformers tune a little broader than normal, and the correct setting is in the midpoint of the broad point. Now that transformers T_1 , T_2 and T_3 are aligned, it should be possible to switch Sw_1 to a.m. reception and hear signals, or at least noise if the converter is on 56 or 43 Mc. There isn't much noise on 112 Mc.

The alignment procedure can be carried on with a speaker connected to the output terminals through an output transformer or, if no speaker is used at this point, the terminals should be shorted with a jumper of wire, otherwise the 6F6 may be injured. The meter for alignment is a necessity, and no attempt should be made to line up the amplifier by ear except for very rough initial alignment.

If you live within the range of an f.m. broadcast station, adjustment of the transformer T_4 is a simple matter. Switch the amplifier on a.m., plug in the proper coils in the converter and tune in the f.m. station. It will sound pretty awful but don't worry about that. Switch the amplifier to f.m. and tune around with the trimmers on T_4 until you start to hear the signal again. This is best done with the audio gain almost wide open and the limiter control set at about half scale. The trimmers are best adjusted with an insulated tool, to reduce body capacity effects, and they should be adjusted until the b.c. signal is clearest and loudest. It will be found that one of the trimmers (plate circuit) will affect the volume mostly, while the trimmer in the grid circuit will have the greatest effect on the quality. During this period of adjustment, the receiver is kept tuned to the signal as indicated by maximum limiter current. If one is available, an audio output meter can be used to determine maximum audio output, although it is not an essential.

In the event that there is no local f.m. broadcast station, the only alternative is to line up the discriminator on an f.m. signal from an

amateur station or, as a last resort, from a $2\frac{1}{2}$ -meter modulated oscillator. The disadvantage with the self-excited u.h.f. oscillator is that it is usually modulated too heavily and it doesn't stay on one frequency long enough to allow the amplifier to be aligned.

The final adjustment of the discriminator tuning can be checked by tuning in an a.m. signal. If the discriminator is properly tuned, the audio output (signal and noise) should practically disappear at the point that the signal as indicated by limiter current is a maximum. This is an indication that the discriminator characteristic crosses the axis at the mid-resonance point of the amplifier. Tuning the signal (by tuning the converter), it should be possible to understand the audio output at points either side of this minimum-volume setting. These points should appear symmetrically on either side of the minimum-volume point and should have about the same volume. Slight readjustment of the discriminator-transformer settings will bring this about.

When using the amplifier, it will be noted that the a.m. signals appear to give louder signals than those from f.m. stations, comparing audio-volume-control settings on stations showing equal limiter current. This doesn't indicate that the amplifier isn't working properly nor does it indicate that more audio is obtained from an a.m. signal than from an f.m. signal of similar strength. It is, however, an indication that the discriminator characteristic could have more slope to it and not have its peaks so far apart. We mention this simply to forestall any inquiries on the part of amateurs experimenting with f.m. amplifiers. As discriminator-transformer construction is improved, this apparent shortcoming will disappear.

The performance of the amplifier on a.m. reception could be improved somewhat by the inclusion of a.v.c. on the two 1852 tubes, taking the a.v.c. voltage from the limiter grid leak through the usual filter circuit. However, this was considered an unnecessary refinement because the amplifier will be used primarily on f.m. reception and the provision for a.m. reception was considered of secondary importance. The amplifier should run "wide open" on f.m. reception. (*Bib. 4*)

Bibliography

- ¹ Noble, *QST*, August, 1939. Grammer & Goodman. *QST*, Jan., 1940.
- ² Grammer, *QST*, June, 1940.
- ³ Goodman, *QST*, Feb., 1940.
- ⁴ Goodman, *QST*, April, 1940.

Antennas for the U.H.F.

Simple and Directive Systems for Use from 28 to 224 Mc.

ULTRA-HIGH-FREQUENCY transmission and reception differs from lower-frequency work in that it is normally carried out by means of semi-optical transmission paths, and it is only on rare occasions that the "sky wave" ever returns to earth and enables long-distance transmission to take place. This is not true, of course, for the 28-Mc. band, where world-wide communication is a regular occurrence during certain parts of the sun-spot cycle. In any event, it is desirable on frequencies higher than 28 Mc. to concentrate the radiated energy as close to the horizontal plane as is practically possible.

On the ultra-high frequencies, signals sent from a vertical antenna (vertically polarized) can only be received well on a vertical antenna, and signals from a horizontal antenna (horizontally polarized) are only received well on a horizontal antenna. Vertical antennas seem to be more common than horizontal ones on the ultra-highs, although there is some evidence that the horizontally-polarized waves provide better signals over long indirect paths.

It has been found that directive antenna systems will extend the operating range on 56-Mc. to such a degree that suitable communication can be carried on with a directive system where no signal could be put through with a simple antenna. Because of the small physical dimensions of antennas on these ultra-high frequencies, and because of their advantages, there is practically no reason why the u.h.f. antenna should not be a directive affair, except possibly in the case of mobile or portable work. Since the only radiation effective at these frequencies is at quite a low angle with respect to the ground, every effort should

be made to concentrate the radiation as near to the horizontal as possible.

It is desirable to keep the Q of the u.h.f. antenna as low as possible, because the bands are proportionately wide and a high-Q system could not be made to take power except over a small portion of the band. "Q" simply relates to the sharpness of resonance of the antenna — a high-Q antenna is one of low radiation resistance and consequently a sharp resonance characteristic. Close-spaced arrays with either driven or parasitic elements are to be avoided because of their high Q, and only the arrays with quarter- or half-wave (or greater) spacing should be used.

The Q of an u.h.f. antenna can be lowered (and thus permit working more readily over the whole band) by using heavy wire or even copper tubing for the elements. Copper tubing of one-inch or even greater diameter is not too unwieldy for the elements of a 56- or 112-Mc. array, and it has the further advantage that self-supporting elements can be used, avoiding any possible loss due to poor insulation at the voltage loops.

It is particularly important that the u.h.f. antenna be placed in the clear and as high as possible. The field strength at a distance is dependent on the height of the antenna, and adding height is like getting more watts output from the transmitter.

Tuned lines can be used to feed the u.h.f. antennas, but untuned ones are recommended, used with suitable matching systems. If an open-wire line is used, either tuned or untuned, it should be carefully balanced as to length, and the spacing should not exceed 4 inches. Coaxial line is excellent for feeding u.h.f.

Fig. 3001 — Two methods of feeding a simple vertical radiator. That shown at A is with a tuned line, while B shows a 56-Mc. antenna with delta match. The dimensions are approximate and may be subject to some slight modification if it is found that coupling the feeders to the tank coil changes the tuning considerably. The 2-foot dimension may have to be changed slightly, to effect a better match, by tapping the line at slightly different points than shown in the sketch.

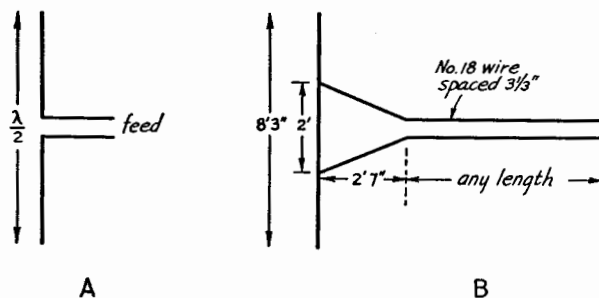

The Radio Amateur's Handbook

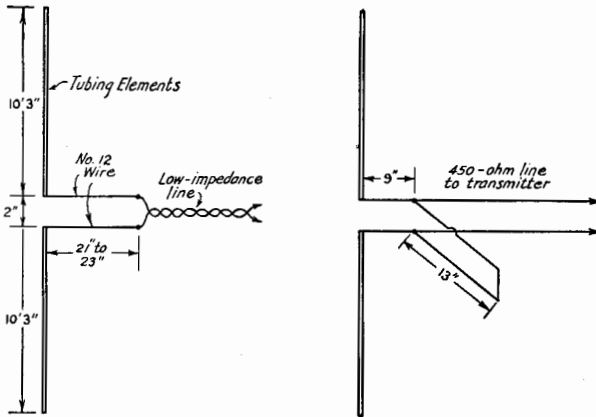

Fig. 3002 — Two methods of feeding an "extended double Zepp" type of collinear array. The dimensions given are for the 56-Mc. band, and should be halved for 112 Mc. The 450-ohm line can be made of No. 12 wire spaced 2 inches. The stub should be adjusted until there is a minimum of change in the final tank circuit tuning when the line is coupled to the transmitter.

antennas. Feed lines should be carefully balanced and made with small spacing to reduce the radiation from the line, since it can become quite serious at these frequencies.

Half-Wave Antennas

Although directive systems are undoubtedly the most effective, good results can be obtained with simple half-wave antennas. They are normally used vertically, so that the radiation will be vertically polarized. Although it is more convenient to end-feed a vertical antenna, center-feed is preferable so that the feed line

can be more readily balanced and remain balanced over the whole band. Tuned feeders can be run to the center of the radiator, or a delta match can be used with an untuned transmission line. Fig. 3001 shows suggested methods of feeding a half-wave radiator for the ultra-high frequencies.

Simple Collinear Antennas

By placing a second vertical element above the first, a collinear antenna results which will give increased low-angle radiation and consequently greater signal strength. Fig. 3002 shows two methods of feeding a type of collinear array known as the "extended double Zepp." This antenna has considerable gain over two simple half waves stacked above each other and, since the difference in required space is not great, its use is recommended over the stacking of two half-wave elements. The twisted-pair type of transmission line will have greater losses than the open line, but it radiates less and is sometimes more effective.

The elements can be made of copper tubing and supported on the side of the pole by stand-off insulators, or the antenna can be of wire suspended from a suitable support. (Bib. 1)

The Coaxial Vertical Radiator

If only a single vertical radiator can be used, and it is necessary to run the line for 30 feet or more, serious thought should be given to the use of coaxial-line feed. It is doubtless the best method of feeding a simple antenna, as testified to by the many police and other u.h.f. installations where no horizontal directivity is desirable but where a maximum of efficiency is required. Although it is possible to run the coaxial line directly to the center of the antenna with no modifications, it is much better to use the method shown in Fig. 3004. This amounts to feeding the antenna at the center with coaxial line but short-circuits the possi-

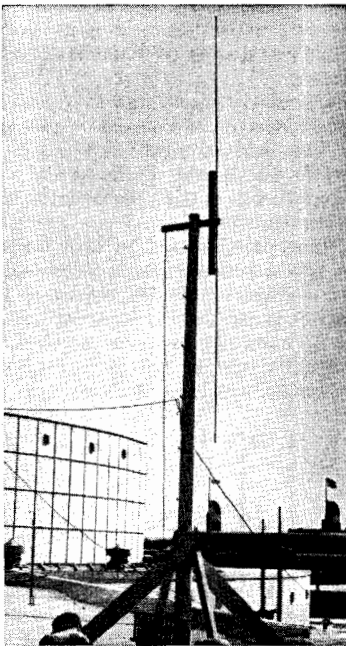

Fig. 3003 — The 56-Mc. antenna at W2USA, dimensions of which are given in Fig. 3002.

Antennas for the U.H.F.

bility that the whole coaxial line may act as a vertical radiator, resulting in high-angle radiation and loss of signal strength. The wire extends a quarter wavelength above the juncture of the line and the outer sheath. Because there is no field in the inside of the sheath, the coaxial

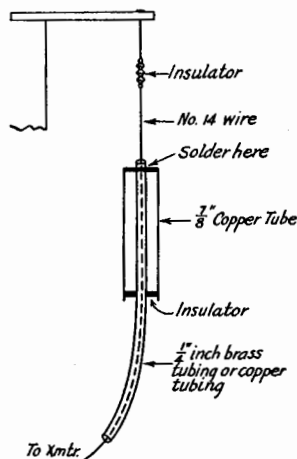

Fig. 3004 — The coaxial vertical radiator is one of the most efficient methods for feeding a vertical half-wave antenna. The wire above the sheath is a quarter-wavelength long, and the sheath is also a quarter-wavelength long. The sheath and wire combine to form a half-wave radiator, and the concentric line feeding the system works to best advantage because of the way it is introduced. If desired, a horizontal ground screen or radial-wire counterpoise can be installed just below the bottom of the sheath (but not connected to it) to increase low-angle radiation. The entire system should be mounted as high as possible. (The sketch of the antenna is one of the systems used at W8PK.)

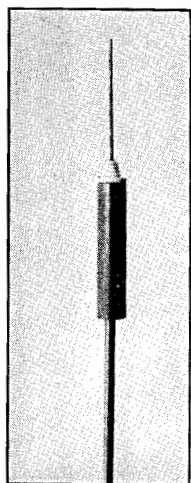

Fig. 3005 — A practical coaxial vertical radiator, used at W6GPY on 325 Mc.

line can run up through it with no harmful effects. This antenna is used in many amateur and commercial installations and always results in increased signal strength over that obtained with a single-half-wave antenna and any other type of feed.

The coaxial line should have an impedance of around 70 ohms, although this is not critical and can range up to 120 ohms without too serious a mismatch. (Bib. 2)

Phased Arrays

Principles other than stacking can be used to obtain greater gains from the u.h.f. antenna, and both the "broadside" and

"end-fire" types of arrays have been used at many stations. One simple application of the "end-fire" principle is shown in Fig. 3006. Two lengths of copper tubing are bent to form a "pitchfork" a half-wavelength long (down to the bend) and with anything from a quarter- to an eighth-wavelength separation. The wider separation will give a lower-Q system and should be used if a matching system of some kind is used or if the feed line has to run for more than several wavelengths. The closer spacing gives slightly greater gain. The end-fire antenna of Fig. 3006 is particularly simple to construct by supporting the two vertical elements of copper tubing from the top of a single vertical pole and running the feed line down the pole.

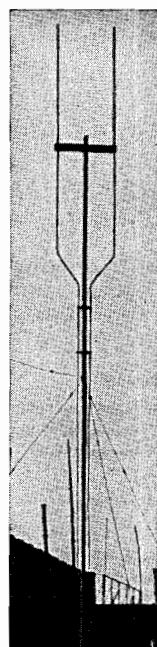

Fig. 3006 — A simple form of end-fire array as used at W2JCR. The two copper-tubing elements are curved in and run down the pole to form part of the feed line.

If the pole can be made to rotate 90°, full advantage can be taken of the directivity of the simple system. While it will not show as sharp a lobe as the broadside type of array, it will show a very definite null which is useful in reducing QRM in congested areas. Its pattern is similar to a figure "8," with the nulls broadside to the plane of the elements.

The broadside arrays, described in Chapter Twenty-four, give good gains and are not too difficult to construct. Several practical applications are shown in Figs. 3007-3009. The elements can be of wire or copper tubing, and the assembly can be simply wires hung from a rope stretched between two supports or it can take the form of a more permanent structure, as shown in the photographs.

The "Corner" Reflector Antenna

A type of antenna system that differs somewhat from any previously described, and one that is particularly well-suited to the u.h.f. ranges above 56 Mc., is the "corner" reflector shown in Fig. 3010.

It is simply two plane surfaces set at an angle of 90°, with the antenna set on a line bisecting this angle. The distance of the antenna from the vertex should be 0.5 wavelength, but some compromise designs can be built with closer spacings (see Table I). The plane surfaces do not need to be solid, and can most easily be made of spines spaced about 0.1 wavelength apart. The spines do not have to be con-

The Radio Amateur's Handbook

Fig. 3007 — The 4 half-waves in phase with reflectors at W7FDJ, illustrating how straightforward can be the construction of a beam antenna for u.h.f.

nected together electrically.

The resistance of the antenna is raised when a corner reflector is used, and this greatly simplifies the problem of feeding. The feedline should be run out at the rear of the reflector, or it can be run through the side. It is, however, preferable to keep it as symmetrical as possible, to avoid any unbalance. Two simple antennas that can be used with the corner reflector are shown in Fig. 3011.

The corner reflector can be used with the antenna either horizontal or vertical, and the plane of polarization will be the plane of the antenna. The relative positions of the antenna and reflector must remain the same, however, which means that a support for both horizontal and vertical polarization would require a means for rotating the reflector about its horizontal axis. (*Bib. 3*)

Other Types of Antennas

Close-spaced arrays with either parasitic or driven elements are not recommended for the

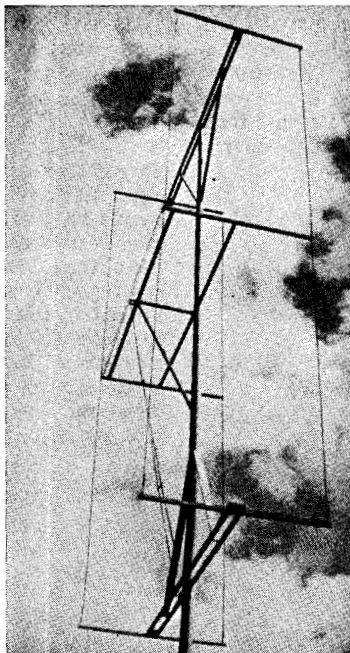

ultra-high frequencies. A possible exception to this rule is the antenna of Fig. 3006, which, while shown with quarter-wave spacing, can be used with spacing as close as one-eighth wavelength when tuned feeders are used. The gain will be slightly higher with the closer spacing but the antenna must be built more rigidly because the closer spacing will make relative motion of the elements more noticeable.

Feeding the U.H.F. Antenna

Close spacing and balance are important factors in u.h.f. feeder operation so that the radiation from the line will be minimized. For this reason, the coaxial line is doubtless the best type of feed for the u.h.f. antenna, but the open-wire line is quite effective if care is taken in its construc-

TABLE I

Frequency Band	Length of Side	Length of Reflector Elements	Number of Reflector Elements	Spacing of Reflector Elements	Spacing of Driven Dipole to Vertex
224-230 Mc. ($1\frac{1}{4}$ meter)	4' 2"	4' 7"	20	5"	2' 2"
112-116 Mc. ($2\frac{1}{2}$ meter)	8' 4"	5' 2"	20	10"	4' 4"
112-116 Mc.* ($2\frac{1}{2}$ meter)	6' 8"	5' 2"	16	10"	3' 6"
56-60 Mc. (5 meter)	16' 8"	10' 4"	20	1' 8"	8' 8"
56-60 Mc.* (5 meter)	13' 4"	10' 4"	16	1' 8"	6' 11"

Table I. — Dimensions of square-corner reflector for the 224-, 112-, and 56-Mc. bands. Alternative designs are listed for the 112- and 56-Mc. bands. These designs, marked (*), have fewer reflector elements and shorter sides, but the effectiveness is only slightly reduced. There is no reflector element at the vertex in any of the designs. The construction is shown in Fig. 3010.

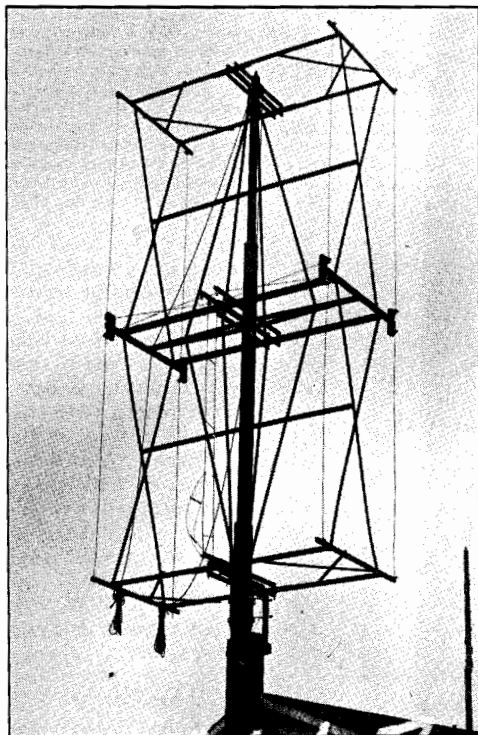

Fig. 3008 — An antenna electrically similar to the one in Fig. 3007, this antenna at W1AZ is built to withstand any kind of weather, and has slip rings in the feeders to allow continuous rotation.

Antennas for the U.H.F.

tion. Low-impedance twisted pair lines, and solid rubber insulated concentric lines are not to be recommended, although they will not be

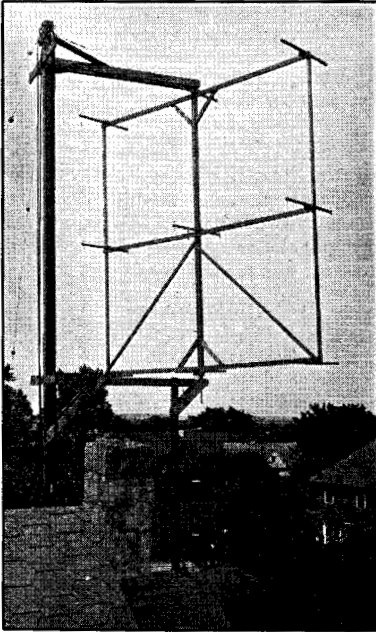

Fig. 3009 — The 112-Mc. array at W2CUZ uses two collinear sets of three broadside driven elements, backed by parasitic reflectors. This type of construction allows rotation of the system.

bad for short distances. The desirable type of coaxial line is one using ceramic beads or some other good material for insulation.

If a matching section is used, it should be symmetrical and loaded on both sides, to maintain current balance in the matching section. If, for example, a single vertical antenna is fed at the bottom by a quarter-wavelength matching section, any radiation from the matching section (due to current unbalance) will combine with the radiation from the antenna to result in a raising of the vertical angle of radiation. Less trouble with feeder radiation will be experienced with any symmetrical sys-

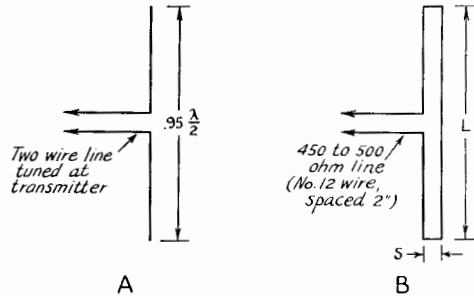

Fig. 3011 — Dipoles suitable for use with the corner reflector antenna system. The length L is 25 inches for 224 Mc., $s = 1$ inch for the same band.

tem, which simply means a system with equal amounts of wire each side of the end of the feeder.

Methods of coupling the transmitter to the feed line are shown in Fig. 3012. At C, the link line running from the transmitter to the antenna tuning unit should be made of No. 12 or 14 wire spaced a half inch or so.

Length of Elements

The formula given for the length of a half-wave antenna on the lower frequencies must be modified somewhat for 56 Mc. and higher because of the greater "end effect" at these frequencies. The length of a half-wave element can be found from

$$\text{Length (inches)} = \frac{5540}{\text{Freq. (Mc.)}}$$

TABLE II

Freq. (Mc.)	Half-Wave Radiator	Half-Wave Open Line
56.0	8' 3"	8' 7"
57.0	8' 1½"	8' 5"
58.0	8'	8' 3"
59.0	7' 10"	8' 1½"
60.0	7' 8½"	8'
112	4' 1½"	4' 3½"
114	4' 1½"	4' 2½"
116	3' 11½"	4' 1½"

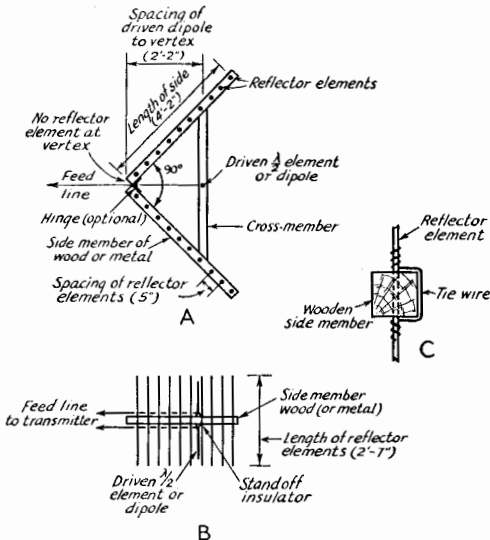

Fig. 3010 — Details of construction of a corner reflector antenna system with grid-type reflector. The reflector elements are stiff wire or tubing. The dimensions are for 224 Mc., and should be doubled for 112 Mc. (See Table I.) The gain of the system is close to 10 db.

The Radio Amateur's Handbook

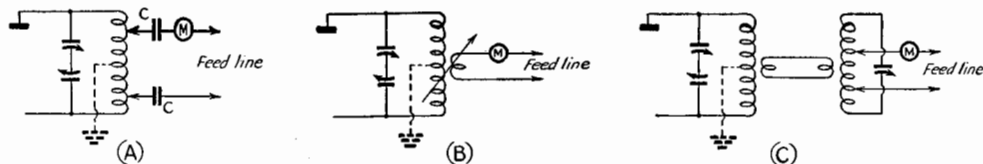

Fig. 3012 — Three types of coupling to feed lines. Those at A and B are used with untuned lines or coaxial line, and that at C is used with either tuned or untuned lines. If a tuned feeder is used, the taps on the coil (in C) should be moved out to the ends of the coil.

The length of a half-wave section of open-wire line is still

$$\text{Length (inches)} = \frac{5760}{\text{Freq. (Mc.)}}$$

For ready reference, typical lengths are tabulated in Table II for the 56- and 112-Mc. bands.

A quarter-wave radiator or open line will

be half the length of the half-wave value.

A reflector element should be spaced a quarter-wavelength back of the radiator and its length made the same as a half wavelength of open line for the same frequency.

Bibliography

1. Lynch, Nov., 1939, *QST*. 2. Long, Jan., 1939, *QST*. 3. Kraus, Nov. 1940, *QST*.

Operating the Station

Operating Routine and Practices — Emergency Procedure — A.R.R.L. Activities

THE transmitter should be adjusted for satisfactory, stable, operation. Do not try to work too near the edge of an amateur band. Keep well *within* the estimated accuracy of your frequency measuring equipment and means of measurement. Check frequency often. Crystal control provides a certain degree of "frequency insurance" but do not omit checks for harmonics and parasitics that may be present with the signal, as well as for frequency changes due to quartz temperature or circuit element capacities if near a band edge. Other control methods require *tremendously increased precautions*. F.C.C. monitoring stations are on the job of checking notes, frequency and other possible discrepancies, so it pays to be watchful.

Method in operating is important, and in this chapter we shall discuss the common practices. The *good* operator does not sit down and send a long call when he wants to work someone. He *listens in*. He covers the dial thoroughly. The fellow that is admired for his good operating is the one who is always calling some particular station instead of using CQ. Because he *listens* until he hears someone to work and *then* goes after him, our good operator gets his man nearly every time. A good operator chooses the proper time to call, he makes plain signals, and he does not call too long. A short call is sufficient because if a station does not get the call it is likely that he is listening to another station. A long call makes the receiving operator lose patience and look for someone else.

Pride in technique is the earmark of the successful amateur among his fellows. Code proficiency sets apart the real seasoned operator from the one who builds equipment only to tear it apart again. Engineering or applied common sense are essential to both the operator and experimenter. Operating ability is just as essential and important in radio-telephone operating as in code work — perhaps it is more essential and more rare, for understanding of phonetics must contribute to conciseness with careful system, as in the airways service, for effective two-way work. The penalty for not having "what it takes" in operating is ineffectiveness in results, as well as to win the name of "lid" by bungling.

Too often the beginner-operator operates his set like a plaything; the aim should be to

operate with a serious and constructive purpose, not for novelty or mere entertainment. It must be remembered that radio communication is not an individual plaything but the interference one causes may affect many others. It may cause pleasure or expressions of annoyance depending on the care and thoughtfulness with which one operates. All of this merely to introduce the plea that time be given to the brief study of operating technique before going on the air.

Many the amateur who complains about his results or blames his equipment when the real fault was with proper timing of calls and failure to do enough intelligent listening. Patience and judgment, and familiarity with tuning methods and ways, and standard procedures are absolutely essential to full success and enjoyment.

The operator who sends forty or more CQ's and signs two or three times in a slipshod manner gains the respect of no one. His call may be impossible to identify. His lack of operating judgment seriously impairs and handicaps *his own success and enjoyment* in addition to causing other amateurs to form an unfavorable opinion of his work and the uncalled-for interference he creates. *By proper procedure* the number of two-way contacts (QSO's) and the enjoyment and profit in each will be a maximum.

The adjustment on the receiver has much to do with successful operation, too. The good receiving operator notes the dial setting and when he has completed calling in proper fashion, he waits a moment and then tunes above or below the logged dial setting just in case something has shifted slightly in the receiver or transmitter. The best operator has patience and waits a few minutes in case of delay at the transmitter or in case fading signals make a second answer necessary. Upon the station and its *operation* depend the possibility of good communication records.

An operator with a clean-cut, slow, steady method of sending has a big advantage over the poor operator. Good sending is partly a matter of practice but patience and judgment are just as important qualities of an operator as a good "fist."

Accuracy is of first importance. Then *speed* must be considered. Very often, transmission at moderate speeds moves traffic or insures

The Radio Amateur's Handbook

understandable conversation better than fast sending. A great deal depends on the proficiency and good judgment of the two operators concerned. Fast sending is helpful only when two fast operators work together.

As time is a factor, uniform practices in operating are necessary to insure a ready understanding. So proficiency in the commonly-used abbreviations and in knowledge of uniform operating practices is to be desired. Proficiency comes with practice. In the Appendix are the "Q" signals and some abbreviations used by amateur operators.

Procedure

Official A.R.R.L. Stations observe the rules regarded as "standard practice" carefully. Any actively-operating stations will do well to copy these rules, to post them conspicuously in the station, and to follow them when operating.

1. Calls should be made by transmitting *not more than three times* the call signal of the station called, and DE, followed by one's own call signal sent *not more than three times*, thus: VE2BE VE2BE VE2BE DE W1AW W1AW W1AW. In amateur practice this form is repeated completely once or twice. The call signal of the calling station *must* be inserted at frequent intervals for identification purposes. Repeating the call signal of the called station five times and signing not more than twice has proved excellent practice in connection with break-in operation (the receiver being kept tuned to the frequency of the called station). The use of a break-in system is highly recommended to save time and reduce unnecessary interference.

The A.R.R.L. method of using the general inquiry call (CQ) is also that of calling three times, signing three times, and repeating three times. CQ is not to be used when testing or when the sender is not expecting or looking for an answer. After CQ, the dial should be covered thoroughly for two or three minutes looking for replies.

The directional CQ: To reduce the number of useless answers and lessen QRM, every CQ call should be made informative when possible. Stations desiring communication should follow each CQ by an indication of direction, district, state, continent, country or the like. International prefixes (Appendix) may be used to identify a particular country. Examples:

A United States station looking for any Canadian amateur calls: CQ VE CQ VE CQ VE DE W1UE W1UE W1UE K. A western station with traffic for the east coast when looking for an intermediate relay station calls: CQ EAST CQ EAST CQ EAST DE W5CEZ W5CEZ W5CEZ K. A station with messages for points in Massachusetts calls: CQ MASS CQ MASS CQ MASS DE W8KKG W8KKG W8KKG K. In each example indicated it is understood that the combination used is repeated three times.

2. **Answering a call:** Call three times (or less); send DE; sign three times (or less); and after contact is established decrease the use of the call signals of both stations *to once or twice*. Example:

W1GNF DE W1AW GE OM GA K (meaning, "Good evening, old man, go ahead").

3. **Ending signals and sign off:** The proper use of AR, K and VA ending signals is as follows: AR (end of transmission) shall be used at the end of messages during communication; and also at the end of a call, *indicating when so used that communication is not yet established*. In the case of CQ calls, the international regulations recommend that K shall follow. K (invitation to transmit) shall also be used at the end of each transmission *when answering or working* another station, carrying the significance of "go ahead." VA (or SK) shall be used by each station only when signing off, this followed by your own call sent once for identification purposes. VA (end of work) sent alone, or for clarification followed by a single (never more) "CQ DE _____," indicates to others that you are through with the station which you have been working and will listen for whom-ever wishes to call. Examples:

(AR) — G2OD DE W1CTI AR (showing that W1CTI has not yet gotten in touch with G2OD but has called and is now listening for his reply). Used after the signature between messages, it indicates the end of one message. There may be a slight pause before starting the second of the series of messages. The courteous and thoughtful operator allows time for the receiving operator to enter the time on the message and put another blank in readiness for the traffic to come. If K is added it means that the operator wishes his first message acknowledged before going on with the second message. If no K is heard, preparations should be made to continue copying.

(K) — ZL2AC DE W6AJM R K. (This arrangement is very often used for the acknowledgment of a transmission. When anyone overhears this he at once knows that the two stations are in touch, communicating with each other, that ZL2AC's transmission was all understood by W6AJM, and that W6AJM is telling ZL2AC to go ahead with more of what he has to say.) W9KJY DE W7NH NR 23 R K. (Evidently W9KJY is sending messages to W7NH. The contact is good. The message was all received correctly. W7NH tells W9KJY to "go ahead" with more.)

(VA) — R NM NW CUL VY 73 AR VA W7WY. (W7WY says "I understand OK, no more now, see you later, very best regards. I am through with you for now and will listen for whomever wishes to call. W7WY signing off.")

4. If a station sends test signals to adjust the transmitter or at the request of another station to permit the latter to adjust its receiving apparatus, the signals must be composed of a series of V's with the call signal of the transmitting station at frequent intervals.

5. When a station receives a call without being certain that the call is intended for it, it should not reply until the call has been repeated and is understood. If it receives the call but is uncertain of the call signal of the send-

Operating the Station

ing station, it should answer using the signal ·· — — ·· (?) instead of the call signal of this latter station. QRZ? (see Appendix) is the appropriate signal to use, followed by your call, to ask who is calling and get this station to call again.

6. Several radiograms may be transmitted in series (QSG. . . .) with the consent of the station which is to receive them. As a general rule, long radiograms should be transmitted in sections of approximately fifty words, each ending with ·· — — ·· (?) meaning, "Have you received the message correctly thus far?"

7. **Receiving** for conversation or traffic: Never send a single acknowledgment until the transmission has been entirely received. "R" means "All right, OK, I understand completely." When a poor operator, commonly called a "lid," has only received part of a message, he answers, "R R R R R R R R R R, sorry, missed address and text, pse repeat" and every good operator who hears, raves inwardly. Use R *only* when *all* is received correctly. Example:

When all the message has been received correctly a short call with "NR 155 R K" or simply "155 K" is sufficient.

8. **Repeats:** When most of the message was lost the call should be followed by the correct abbreviations (see Appendix) from the international list, asking for a repetition of the address, text, etc. (RPT ADR AND TXT K.) When but a few words were lost the last word received correctly is given after ?AA, meaning that "all after" this should be repeated. ?AB for "all before" a stated word should be used if most of the first part of the copy is missing. ?BN AND (two stated words) asks for a fill "between" certain sections. If only a word or two is lost this is the quickest method to get it repeated.

Do not send words twice (QSZ) unless it is requested. Send single. Do not fall into the bad habit of sending double *without a request* from fellows you work.

Do not accept or start incomplete messages.

9. A file of messages handled must be kept, F.C.C. regulations requiring that they be maintained on hand at least one year.

10. The operator will *never make changes or alterations in the texts or other portions of messages passing through his hands.* However slight or however desirable such changes may seem, the changing of a message without proper authority or without the knowledge of the originator of the message may be considered the "unpardonable sin." The proper thing to do of course is to notify the party filing the message or the originating station of your observations, secure permission from the proper source for making the change by sending a "service message" or other means. If the

case seems urgent, the traffic should not be delayed but should be delivered or forwarded with appropriate notation or service accompanying it.

Activities — Contests

Operating in the amateur bands offers many thrills. Routine communication is possible, but even the most consistent and reliable communication by amateur radio is not at all limited to routine. The "unexpected" is always around the corner. A pleasant experience may arrive in the form of unusual DX, a renewed friendship over the air, a chance to render message service in some special case, or a sudden communication emergency in which one may play a part.

Special activities are sponsored by the American Radio Relay League, adding to ham interest and fraternalism at the same time opportunity is given for testing station performance over definite periods, making new friendships and QSOs, and developing operating technique. A.R.R.L. also coöperates with foreign amateur societies in many jointly publicized programs for the operating man that have similar beneficial aims.

Contest activities are diversified as greatly as possible to appeal to every classification of amateur interest showing a desire to participate. The most well known of all are the annual Sweepstakes, and the Field Day, appealing to all groups.

The annual Navy Day Receiving Competition is managed by the A.R.R.L. in late October, an opportunity for any receiving ham to check his copying ability and proficiency by getting the telegraphic dispatches sent from NAA and NPG to amateurs on the occasion of Navy Day, October 27th. An "honor roll" in QST and letters of commendation follow this event.

One of the very biggest events of the year is the annual Sweepstakes Contest which has potentialities of operating fun and new QSOs for everybody, the operation extending to all bands. Each November the rules for this are announced. A large number of contacts, new stations, new Sections and other operating records are always reported in and after the "SS" and the spirit of fraternalism prevails. The magic key to open the door to QSOs, new and old, during the Sweepstakes is a CQ SS, sent in a snappy manner, by any ham, anywhere in the 72 A.R.R.L. Sections.

In December a Copying Bee has been arranged. The League offers a special award to the most proficient. Unusual word and figure combinations are transmitted at a fairly rapid speed by tape transmitters from three or four of the more powerful amateur stations throughout the country. Note the schedules in December QST and report your copy from one of

The Radio Amateur's Handbook

The Radio Amateur's Handbook

these stations to A.R.R.L. Coöperative announcements of operating arrangements with other societies are often made for December and January, also.

Of major importance in the League's operating program, is the annual A.R.R.L. Field Day held on a week-end in June, combining the out-of-door opportunities with the Field testing of portables. As in all our operating, the idea of having a good time is combined with the more serious thought of preparing ourselves to shoulder the communication load as emergencies turn up and the occasion requires. A premium is placed on the use of low or medium power, on portability, and on the use of equipment without connection to commercial sources of power supply. Clubs as well as individuals have a major part in this.

Working DX

Hams who do not raise DX stations readily may find that their sending is poor, their calls ill-timed or judgment in error. It is usually *wasted* effort for W/VE stations to send CQ DX. When conditions are right to bring in the DX, and the receiver sensitive enough to bring in several stations from the desired locality, the way to raise DX is to use the appropriate frequency and to *call these stations*. Reasonably *short* calls, with appropriate and brief breaks to listen will raise stations with minimum time and trouble. The reason W/VE CQs do not raise DX is that the number of U. S. A. and Canadian hams is so great that it is always possible for a foreign station to find a large number of W/VE's calling, without wasting time on stations not definitely looking for his station.

A sensitive receiver is often more important than the power input in working foreigners. There is not much difference in results with the different powers used, though 500 watts will probably give 10% better signal strength at

the distant point than 100 watts, other factors being the same. It will not do much better than this because the field strength drops so rapidly as we get away from the antenna. In working foreign countries and DX stations you should be able to hear ten or a dozen stations before expecting that one of them will hear you call.

Conditions in the transmission medium make all field strengths from a given region more nearly equal at a distance, irrespective of power used. In general, the higher the frequency band the less important "power" considerations become.

General Practices

The signal "V" is used for testing. When one station has trouble in receiving, the operator asks the transmitting station to "QSV" while he tries to adjust his receiving set for better reception. A decimal point is often sent by the letter "R." Example: 2:30 PM is sent "2R30PM." A long dash for "zero" and the Morse C (. . .) for "clear" are in common use. Figures are best spelled out in texts, for highest accuracy. An operator who misses directions for a repeat will send "4," meaning, "Please start me, where?" NFT for "no filing time" is common.

The law concerning superfluous signals should be noted carefully by every amateur. Do not hold the key down for long periods of time when testing or thinking of something to send. If you must test, disconnect the antenna system and use an equivalent "dummy" antenna (made of lumped resistance, capacity and inductance). Send your call frequently when operating with the antenna. Pick a time for adjusting the station apparatus when few stations will be bothered.

Long calls after communication has been established are unnecessary and inexcusable. The up-to-date amateur station uses a "break-in" system of operation and just one switch controlling the power supply to the transmitter. The best sending speed is a medium speed with the letters quickly formed and sent evenly with proper spacing. The standard type telegraph key is best for all-



One of these Proficiency Certificates may be awarded to you. Try for it, by copying W1AW at 10:30 p.m. E.S.T. on dates announced in QST for monthly official qualifying runs. If you can do 15, 20, 25, 30 or 35 w.p.m. your certificate will so state! Every F.C.C. amateur licensee is eligible.

The material is sent simultaneously on 1761, 3825, 7280, 14253, and 28,510 kc.- from W1AW. There are *practice* runs starting 15 minutes to 20 minutes earlier daily, except Friday, from W1AW.

Operating the Station

round use. Before any freak keys are used a few months should be spent listening-in and practicing with a buzzer. Regular daily practice periods, two or three half hour periods a day, are best to acquire real familiarity and proficiency with code.

No excuse can be made for a "garbled" text. Operators should copy what is sent and refuse to acknowledge messages until every word has been received correctly. *Good operators never guess.* "Swing" in a fist is *not* the mark of a good operator, is undesirable. Unusual words are sent twice, the word repeated following transmission of "?". If *not sure*, good operators systematically ask for fills or repeats.

Don't say, "QRM" or "QRN" when you mean "QRS."

Don't acknowledge any message until you have received it completely.

Don't CQ unless there is definite reason for so doing. When sending CQ, use judgment. Sign your call frequently, interspersed with calls, and at the end of all transmissions.

Abbreviated standard procedure deserves a word in the interest of brevity on the air. Abbreviated practices help to cut down unnecessary transmission. However, make it a rule not to abbreviate unnecessarily when working an operator of unknown experience.

NIL is shorter than *QRU CU NEXT SKED*. Instead of using the completely spelled out preamble *HR MSG NR 287 W1GME CK 18 MIDDLEBURY CONN OCTOBER 28 TO*, etc., transmission can be saved by using *287 W1GME 18 MIDDLEBURY CT OCT 28 TO*, etc. One more thing that conserves operating time is the cultivation of the operating practice of writing down "287 W1UE 615P 11/13/37" with the free hand during the sending of the next message.

"Handling" a message always includes the transmission and receipt of radio acknowledgment (QSL) of same, and entry of date, time and station call *on the traffic*, as handled, for purposes of record.

Procedure for Voice Work

Most broadcasting work is casual and merely one-way communication while amateur radio and point-to-point services such as the airways require the specific attention of the listener, and receipting for all transmissions. The International Telecommunications Convention and the supplementary regulations thereto prescribe method and system for time saving and maximum understandability. The most effective amateur voice operation conforms closely, where *accuracy* is the required objective, and examples of such procedure in accordance with the universal practice will be given. The general practices of radio extend to voice and telegraph alike and may be fol-

lowed with the special voice procedure mentioned.

At the start of communication the calling formula is spoken twice by both the station called and the calling station. After contact is established it is spoken once only. Examples:

W5QL calls: "Hello W3JZ Philadelphia, hello W3JZ Philadelphia, W5QL Oklahoma City calling, W5QL Oklahoma City calling, message for you, message for you, come in please."

W3JZ replies: "Hello W5QL Oklahoma City, hello W5QL Oklahoma City, W3JZ Philadelphia answering, W3JZ Philadelphia answering, send your message, send your message, come in please."

W5QL replies: "Hello W3JZ Philadelphia, W5QL Oklahoma City answering, the message begins, from Oklahoma City Oklahoma W5QL number [usual preamble, address, text, signature, etc.], message ends; I repeat, the message begins, from Oklahoma City Oklahoma W5QL number [repetition of preamble, address, text, signature, etc.], message ends, come in please."

W3JZ replies: "Hello W5QL Oklahoma City, W3JZ Philadelphia answering, your message begins, from Oklahoma City Oklahoma W5QL number [repetition of complete message], end of your message, come in please."

W5QL replies: "Hello W3JZ Philadelphia, W5QL Oklahoma City answering, you have the message correctly, you have the message correctly, W5QL Oklahoma City signing off."

Note that in handling traffic by voice, messages are repeated *twice* for accuracy, using the word list to spell names and prevent misunderstandings: The receiving station must repeat the message *back in addition*. Only when the sender *confirms* the repetition as correct can the message be regarded as handled.

Word List for Accurate Transmission

When sending *messages* containing radio calls or initials likely to be confused and where errors must be avoided, the calls or initials should be thrown into short code words:

A — ABLE	J — JIG	S — SAIL
B — BOY	K — KING	T — TARE
C — CAST	L — LOVE	U — UNIT
D — DOG	M — MIKE	V — VICE
E — EAST	N — NAN	W — WATCH
F — FOX	O — OBOE	X — X-RAY
G — GEORGE	P — PUP	Y — YOKE
H — HAVE	Q — QUACK	Z — ZED
I — ITEM	R — ROT	

Example: *W1BCG* is sent as *WATCH ONE BOY CAST GEORGE*.

A somewhat different list can be obtained from the local Western Union telegraph office and posted beside the telephone to use when telephoning messages containing initials and difficult words. Such code words prevent errors due to phonetic similarity. Here is the Western Union word-list:

A — ADAMS	J — JOHN	S — SUGAR
B — BOSTON	K — KING	T — THOMAS
C — CHICAGO	L — LINCOLN	U — UNION
D — DENVER	M — MARY	V — VICTOR
E — EDWARD	N — NEW YORK	W — WILLIAM
F — FRANK	O — OCEAN	X — X-RAY
G — GEORGE	P — PETER	Y — YOUNG
H — HENRY	Q — QUEEN	Z — ZERO
I — IDA	R — ROBERT	

The Radio Amateur's Handbook

Names of states and countries are often used for identifying letters in amateur radiotelephone work, the possible objection being the confusion of the names of places with the station's location. It is recommended by A.R.R.L. that use of special abbreviations such as Q code be minimized insofar as possible in voice work, and that full expression (with conciseness) be substituted. O.P.S. have adopted the Western Union word list as A.R.R.L. practice for avoiding difficulty with phonetic similarity. All word lists should be used in moderation, as necessary in avoiding misunderstanding, and at the end of calls not more than once.

Using a Break-In System

If you aim to have the best, and every ham does, you will have break-in, whether of the push-to-talk or open the key variety, but if you haven't the ideal installation yet, by all means operate intelligently and take every advantage of the other fellow's facilities when break-in is offered! Break-in avoids unnecessarily long calls, prevents QRM, gives you more communication per hour of operating. Brief calls with frequent short pauses for reply can approach (but not equal) break-in efficiency.

A separate receiving antenna makes it possible to listen to most stations while the transmitting tubes are lighted. It is only necessary with break-in to pause just a moment occasionally when the key is up (or to cut the carrier momentarily and pause in a 'phone conversation) to listen for the other station. The click when the carrier is cut off is as effective as the word "break."

For 'phone a push button to put the carrier on the air only while talking is a completely practical device, and amateur 'phone operators would do well to emulate the push-to-talk efficiency of the airways operators to improve conditions in the 'phone bands.

C.w. telegraph break-in is usually simple to arrange. With break-in, ideas and messages to be transmitted can be pulled right through the holes in the QRM. Snappy, effective, efficient, enjoyable amateur work really requires but a simple switching arrangement in your station to cut off the power and switch 'phones from monitor to receiver. If trouble occurs the sending station can "stand by" (QRX), or it can take traffic until the reception conditions at the distant point are again good.

In calling, the transmitting operator sends the letters "BK," "BK IN," or "BK ME" at frequent intervals during his call so that stations hearing the call may know that a break-in is in use and take advantage of the fact. *He pauses at intervals* during his call, to listen for a moment for a reply from the station being called. If the station being called does not

answer the call can be continued. If the station called answers someone else, he will be heard and the calling can be broken off. With full break-in, transmitter may be remotely controlled so no receiver switching is necessary. A tap of the key, and the man on the receiving end can interrupt (if a word is missed) since the receiver is monitoring, awaiting just such directions constantly. But it is not necessary that *you* have such complete perfect facilities to take advantage of break-in when the stations you work are break-in equipped. It is not intelligent handling of a station or coöperation with an operator advertising that he has "bk in" with his calls, to sit idly by minute after minute of a properly sent call. After the first invitation to break is given and at each subsequent pause turn on your transmitter and tap your key — and you will find that conversation or business can start immediately.

Keeping a Log

The F.C.C. requires every amateur to keep a complete station operating record. It may

AMATEUR RADIO STATION LOG											
Date of first use		1935		Station No.		123		Frequency, 2245 Kcs.			
Type of station		AL		Type of vehicle or mobile use		None		Approximate location			
Type of vehicle or mobile use		None		Type of vehicle or mobile use		None		Remarks and comments, please reproduce prominent facts, etc.			
DATE	STATION	CALLS	BY	STATION	RECEIVED	OR	REMARKS	CLASS	TIME	REMARKS	REMARKS
TIME	CLASS	X	Y	BY	BY	BY	BY	BY	BY	BY	BY
4:57 PM	W6TPI	X	3	4	3	5	9	6:25 PM		None open!	
6:08	W6STP	X	5	7	7					No. dup.	
6:34	W6TPI	X	4	6	2	5	6	8:12		W6TPI close 1/2 way down!	
6:37	W6TPI	X	4	6	2	5	6	8:12		Business, Calif.	50
7:24	CA	X									
7:22	X	W6DPE	3	4	9			3	9	7:33	Too early for 2nd sign-out
7:45											off for evening
7:50	W6ARS	X						7:50 AM		None	50
7:51	W6ARS	X						7:53		Closed about 7:50	
8:07	CA	X									
8:23	W6FLG	X	5	9	7	5	7	8:38		W6FLG at key time	
8:40	CA	W6BVA	5	9	5	4				Switched sig!	
8:40 PM	CA	X									
8:42	X	W6ACH	5	7	7			8:24 PM		Trans Line Station	50
8:52	W6GSH	X						8:57		Los Angeles	
7:00	ART	X									

KEEP AN ACCURATE AND COMPLETE STATION LOG AT ALL TIMES! THE F.C.C. REQUIRES IT

The official A.R.R.L. log is shown above, answering every government requirement in respect to station records. Bound logs made up in accord with the above form can be obtained from Headquarters for a nominal sum or you can prepare your own, in which case we offer this form as a suggestion, hoping that you find it worthy of adoption. Every station must keep some sort of a log. The above log has a special wire binding and lies perfectly flat on the table.

also contain records of experimental tests and adjustment data. A stenographer's notebook can be ruled with vertical lines in any form to suit the user. The Federal Communications Commission requirements are that a log be maintained which shows (1) the date and time of each transmission, (2) all calls and transmissions made (whether two way contacts resulted or not), (3) the input power to the last stage of the transmitter, (4) the frequency band used, (5) the time of ending each QSO

Operating the Station

and the operator's identifying signature for responsibility for each session of operating. Messages may be written in the log or separate records kept — but record must be made for one year as required by the F.C.C. For the convenience of amateurs A.R.R.L. stocks both log books and message blanks, and if one uses the official log he is sure to fully comply with the government requirements if the precautions and suggestions included in the log are followed.

The R-S-T System of Signal Reports

The R-S-T system is an abbreviated method of indicating the main characteristics of a received signal, the Readability, Signal Strength, and Tone. The letters R-S-T determine the order of sending the report. In asking for this form of report, one transmits RST? or simply QRK?

READABILITY

- 1 — Unreadable
- 2 — Barely readable, occasional words distinguishable
- 3 — Readable with considerable difficulty
- 4 — Readable with practically no difficulty
- 5 — Perfectly readable

SIGNAL STRENGTH

- 1 — Faint — signals barely perceptible
- 2 — Very weak signals
- 3 — Weak signals
- 4 — Fair signals
- 5 — Fairly good signals
- 6 — Good signals
- 7 — Moderately strong signals
- 8 — Strong signals
- 9 — Extremely strong signals

TONE

- 1 — Extremely rough hissing note
- 2 — Very rough a.c. note, no trace of musicality
- 3 — Rough, low-pitched a.c. note, slightly musical
- 4 — Rather rough a.c. note, moderately musical
- 5 — Musically modulated note
- 6 — Modulated note, slight trace of whistle
- 7 — Near d.c. note, smooth ripple
- 8 — Good d.c. note, just a trace of ripple
- 9 — Purest d.c. note

(If the note appears to be crystal controlled simply add an X after the appropriate number.)

Such a signal report as "RST 387X" (abbreviated to 387X) will be interpreted as "Your signals are readable with considerable difficulty; good signals (strength); near d.c. note, smooth ripple; crystal characteristic noticed." Unless it is desired to comment in regard to a crystal characteristic of the signal, a single three-numeral group will constitute a complete report on an amateur signal. The

R-S-T system is the standard A.R.R.L. method of reporting. Various report combinations are based on the table.

Emergency Operating Precautions¹

In emergency operating a fine sense of discrimination is necessary. Desire to help through *transmitting* participation is often a dangerous thing. Careful listening locates stations, places, nets, keeps general calls at minimum and enables handling traffic efficiently responsive to the CQ of an emergency area station. "Talking it over" and general chatter should be *reserved* until emergency conditions no longer exist.

As soon as the F.C.C. has "declared" a condition of general communications emergency, special amateur regulations (Sec. 152.54) govern absolutely, with the following provisions effective until the Commission declares the emergency ended:

1. No transmissions in the 80- or 160-meter bands may be made *except* those relating to the relief or emergency service. Casual conversation, incidental calling or testing, remarks not pertinent to the constructive handling of the emergency communications, shall be prohibited.

2. 25-kc. band-edge segments shall be reserved at all times for (a) emergency calling channels, (b) initial calls from the isolated, (c) first calls initiating dispatch of important priority relief matters. All stations shall, for general communication, shift to other within-band frequencies for carrying on communication. The channels for calling ONLY, in emergencies, are: 2025-2050 3500-3525 and 3975-4000 kcs.

3. Hourly observance of mandatory quiet or listening periods, the first five minutes of each hour. (No calls may be answered in this period. Only "utmost priority" traffic may continue.)

4. For promulgating the emergency-declaration, for policing-warning-observing work in 1750-2050 and 3500-4000 kc. bands, F.C.C. may designate certain amateur stations. Announcements from these stations will be identified by their reference to Sec. 152.54 by number, and their specification of the date of the F.C.C.'s declaration, with statement of the area and nature of the emergency.

Where a communications emergency is part of a general emergency accompanied by relief problems and movements of the population it will be found that many refugees are created by the situation and deliveries of ingoing messages to these people are well nigh impossible. There is great good will as a result of handling personal safety messages in each instance where delivery can be effected, but it must be remembered that relief problems of the community at large, official messages from Red Cross, military and civic officials have *absolute priority*. Radio circuits must carry the important messages first, and when personal safety messages are permissible in the judgment of operators in the affected area it is even then much more profitable to have the burden of traffic outgoing messages of safety rather

The Radio Amateur's Handbook

than requests for investigating safety which cannot be acted upon except at a deferred date. Organization must avoid unnecessary duplication of channels, must load telegraph circuits properly to avoid congesting telephone channels where fewer circuits are available. Messages should be routed for point to point delivery by a single channel, and no irritating duplications or repeating of the same messages (broadcast) be permitted where this can be avoided. The function of broadcasting stations is to reach the public, that of amateur stations to handle point to point information efficiently with as little public excitement as possible and maximum secrecy for texts of official messages and any information that might start rumors.

It is important that originating stations *number* their messages and *put them in standard form*. That makes the work systematic and respected and takes it out of the hit or miss classification into which casual exchanges fall in the minds of recipients. Such method in all amateur work instantly nails duplicate messages, makes tracing possible, and makes amateur performance comparable with that of other communication services.

Unauthorized broadcasting and modifying of broadcasts addressed to the amateur service has caused difficulty in major emergencies of recent years. Rumors are started by unintelligent expansion or contraction (and subsequent repetitions) of broadcast dispatches. It is improper and deserving of censure and severe penalties to delete essential limiting words that qualify a message, to expand, exaggerate, or alter meanings. Broadcasts should include their source and authority; they should be repeated exactly if at all, or not repeated; League and F.C.C. transmissions through vigilante appointees in emergencies of the future will as in the past extend no authority, or specified limited authority, to rebroadcast.

The League's Emergency Corps has adopted the principles tabulated for "before — in — after emergencies" and in addition is pledged to a man to observe the following:

... to confirm the authenticity of reports, and as a responsible individual avoid publication or transmission of any rumor, except labelled as such. (Vital information should be released only when verified by proper authority. Make your operation in connection with official agencies such as the Red Cross, civil and military authorities so that messages may be signed by *officials* in as many cases as possible.)

... to work closely with any A.R.R.L. (city or regional) Emergency Coordinator that may be appointed. Also to cooperate with Section Communications Manager, Route Manager, or Phone Activities Manager in any definite steps for emergency organization.

... to have proper regard to priority of communications. To keep quiet (QRX) as much as possible to reduce interference. Priority is normally determined within the emergency zone itself.

... to become acquainted with the special frequencies and facilities of organized amateur groups, the A.A.R.S. and U.S.N.R.

... to use QRR *only* if necessary, and then use it correctly. (It may *ONLY* be used by a station in an emergency zone with an actual distress message.)

Emergency Communication¹

A communications emergency occurs whenever normal facilities are interrupted or overloaded, and may or may not involve general public participation. A communications emergency need not involve a public relief or welfare emergency, but the latter condition usually is accompanied by a communications emergency.

In scores of emergencies radio amateurs have given a good account of themselves. Radio has proved the only agency to span the gap with power failing and wires down. Since our amateur stations are of the most numerous class licensed, because they are located anywhere and everywhere, many are located strategically to give an account of themselves as need arises. Those amateurs best *prepared* before trouble comes are credited with having played most important parts. It should be a matter of pride with every amateur to fit himself as a superlative *operator*, and equip himself with apparatus with an eye to emergencies when power may evaporate from customary commercial sources with a view to carrying on the vital service of amateur communication if urgent opportunity for a service large or small arrives.

We serve *best* by manning a few powerful, best situated stations with amateur operators in 8-hour shifts, rather than inadequately manning too many amateur stations with overworked operators creating band congestion.

Those we serve in widespread emergency are the Red Cross, civil and military authorities, transportation agencies, power-gas-light-water utilities, the Coast Guard, Army engineers and others. In doing this we often work hand in hand with other wire and radio services as well as with each other.

In the event of new cases of serious and widespread communications emergency, it is likely that the F.C.C. will follow precedent (and its new regulations, Sec. 152.54) and again declare a general communications emergency. Then, as in the Ohio valley flood (1937) it is likely that F.C.C. will call on your A.R.R.L. to recommend policing-observing stations for F.C.C. to appoint in the different amateur bands to function for the duration of the emergency. A.R.R.L. stands ready with its experience, its program of preparedness, and its member-station organization in which every live amateur who volunteers has a part.

Monitored Frequencies

A few words on the last two points: In dire disaster where life and property are threatened and a region is isolated except for wireless

Operating the Station

BEFORE EMERGENCIES

Be ready, with emergency power supply. Six-volt tubes in exciters and receivers make for convertibility and utility in portable work where gas engine generators are not available. Overhaul and test periodically.

Test set operator ability in A.R.R.L. Field Day and Contests. Give local officials and agencies your address; explain amateur facilities; act via the A.R.R.L. Emergency Coördinator wherever one is appointed.

IN EMERGENCY

REPORT at once to the A.R.R.L. Emergency Coördinator so he will have full data on availability of stations — operators — circuits. Work direct with agencies we serve where no appointed official is in charge, and when so assigned.

CHECK station operating facilities; offer services to all who may use them, via Coördinator or helping official where one is available.

QRR is the official A.R.R.L. "land SOS," a distress call for emergency uses *only* . . . for use *only* by station asking assistance.

RESTRICT all work in accord with F.C.C. regulations,² Sec. 152.54, as soon as F.C.C. has "declared" a state of communications emergency.

THE KEY STATION in emergency zone is the first and the supreme authority for priority and traffic routing in the early stages of emergency relief communications.

PRIORITY must be given messages in the general public interest (relief plans, re food, medicine, necessities). Press reports and personal assurance messages can then be handled if practicable.

COÖPERATION is required of all amateurs with those we serve; with other communication agencies. Don't clutter air with CQ's. The majority of amateurs must *listen in*; QRX, avoid QRMing. Be ready to help; operate as intelligently as possible; coöperate by staying off the air while vital information and relief measures are handled, if stations able to help as well as yours are on the job. (CQ STORM AREA is nothing but "more QRM.")

AFTER EMERGENCIES

REPORT to A.R.R.L. as soon as possible and as fully as possible so amateur radio can receive full credit. Amateur radio communication in 52 major disasters since 1919 has won glowing public tribute. Maintain this record.

communication, government aid may be secured when all attempts on normal channels have failed, by "breaking" an existing government circuit. A.A.R.S. use 6990-, 3497½-, etc., kcs. Naval shore stations guard certain frequencies constantly, also. In the east 4040-4075, 4235- and 8920- kcs. at night, or 7995 kcs. in daylight hours, and in the west 4010-, 4235-, 4525- and 7995- kcs. are the night, with 8150 kc. a day frequency.

Emergency Calling Frequencies

Regarding QRR, which call is limited to use of isolated stations for first emergency calls, special provision and methods are necessary to assist the stations under handicap of no commercial power in remote sections in getting contact and help. Their problem is vital, and different from the problem of casual participation by the amateur community at large.

It is recommended by A.R.R.L. that frequencies *at the band edges* be utilized for emergency calls, with no general emergency declared or in effect. This lends point and specification to builders of emergency equipment. This spot on all bands is well covered continuously by receivers. It gives hope to the isolated operator that he be heard. At such frequencies all listeners are instructed to hunt for weak signals in any periods in general emergency established for taking account of the isolated, and establishing new important connections.

The F.C.C. regulations² now require that in general emergency 2050-2025 kcs., 4000-3975 kcs. and 3500-3525 kcs. shall be reserved as *emergency calling channels* — prohibited to all stations except for first emergency or QRR calls, and initial or important emergency relief traffic or arrangements, *whenever F.C.C. shall have recognized and declared a general communications emergency exists*. All stations using such channels shall as rapidly as practicable shift to normal working and calling frequencies, to leave these emergency channels clear for important calls of this type.

The Federal Communications Commission rules also require that in emergency, all amateur stations in the designated areas observe a silent or listening period for the *first five minutes of each hour* (0000-0005), *on all amateur channels* (3500-4000 kcs., 1750-2000 kcs.), tuning through the emergency calling channels and other channels for any QRR or initial-important calls from weak stations, previously unheard in interference.

The League requests the fullest collaboration³ and coöperation of all amateurs to add to our public service record. *Preparedness* of station and operator is the first step. Voluntary enlistment of every amateur is requested (1) in abiding by the precepts above outlined (2) in registering in the A.R.R.L. Emergency

The Radio Amateur's Handbook

Corps (3) in cooperation for local community and regional planning and tests, which will be initiated by appointed coordinators and other League Officials (4) in building self-powered equipment.

After emergency (large or small) full individual reports to the A.R.R.L. Communications Department are requested for the amateur service record. The part that every amateur played must be recorded not only for the *QST* account, but to strengthen and support the running record of amateur achievement.

From analysis of all reports A.R.R.L. Public Service Certificates are awarded for notable "public service" work.

Stations outside an "emergency zone" in communication with relief stations in that zone are requested to inform A.R.R.L. Headquarters at once of this situation by telegram to facilitate traffic movement and for the information of the press.

Message Handling

Amateur traffic handling is highly developed and effective, *if one knows how to use it*. Don't expect that you can get on the air with the message you have written and give it to the first station that comes along and expect miracles to happen. You fellows who get your fun principally from DX, rag chewing, and building equipment should appreciate that you must place the occasional message *you* start and wish to have reach its destination, not in the hands of others like yourselves, but in the hands of one of the many operators who *specialize* in keeping schedules and handling messages, one who gets his fun mainly out of this branch of our hobby, who knows the best current routes and is in a position to use them.

Station owners may originate traffic of *any kind* going to any part of the United States, Hawaii, Porto Rico, Alaska, or the Philippines.

Messages should be put in as complete form as possible before transmitting them. *Incom-*

plete messages should not be accepted. As messages are often relayed through several stations before arriving at their destination, *no abbreviations should be used in the text* as mistakes are bound to happen when the text is shortened in this manner. To people not acquainted with radio abbreviations, messages written in shortened form are meaningless. Delivering stations must be careful to see that messages are written out fully.

In handling messages we are doing something really worth while. We want to start only good worth-while messages from our stations. Our efforts should be directed to making the quality of our message service high. The number of messages we handle is of secondary importance. The *kind of messages* we originate or start from our stations and the *speed* with which the messages pass through our station and the *reliability or accuracy* with which the messages are handled are the things of paramount importance.

Just as the ultimate aim of amateur radio on all frequency bands is *communication*, so is the relaying of word by radiogram a "natural" when one has something to say to a party beyond immediate reach. Not all hams perhaps appreciate the utility that results from using amateur message service in our ham correspondence. However, no ham, not even a new member of the brotherhood, but feels the satisfaction of having really accomplished something tangible in exchanging a message (recorded communication) with another amateur. Of course not all beginners develop the advanced operating technique of the finished message handler, but it is within the reach of all who will try.

The amateur who handles traffic is automatically training himself to do the kind of a job official agencies desire in emergencies, and he becomes a valuable exponent of the whole amateur service.

Message Form

Each message originated and handled should contain the following component parts in the order given:

- (a) Number
- (b) Station of Origin
- (c) Check
- (d) Place of Origin
- (e) Time Filed
- (f) Date
- (g) Address
- (h) Text
- (i) Signature

A standard form enables one to know just what is coming next, and makes accuracy possible with speed. Start some messages to familiarize yourself with the proper way to

Operating the Station

write and send traffic in good form. Just as you would be ashamed to admit it if you could not qualify as an experienced amateur by at least "15 w.p.m." code capability, be equally proud of your basic knowledge of how to properly form and send record communications.

(a) Every message transmitted should bear a "number." On the first day of each calendar year, each transmitting station establishes a new series of numbers, beginning at No. 1. Keep a sheet with a consecutive list of numbers handy. File all messages without numbers. When you send the messages, assign numbers to them from the "number sheet," scratching off the numbers on that list as you do so, making a notation on the number sheet of the station to which the message was sent and the date. Such a system is convenient for reference to the number of messages originated each month.

(b) The "station of origin" refers to the call of the station at which the message was filed. This should always be included so that a "service" message may be sent back to the originating station if something interferes with the prompt handling or delivery of a message. In the example in "d" below, W1AW is the station of origin, that call being the one assigned the station at the national headquarters of the League.

(c) Every word and numeral in the text of a message counts in the check. Full information on checking messages is given later in this chapter.

(d) The "place of origin" refers to the name of the city from which the message was started. If a message is filed at League Headquarters by someone in West Hartford, Conn., the preamble reads *Nr 467 W1AW ck 21 West Hartford Conn 8R57 p June 11, etc.*

If a message is sent to your radio station by mail the preamble shows the place of origin as the town where the message came from. If a message was filed at A.R.R.L. Headquarters and if it came by mail from Wiscasset, Maine, the preamble would run like this to avoid confusion: *Hr msg nr 467 W1AW ck 21 Wiscasset Maine 8R57 p June 11, etc.*

(e) The time filed is the time at which the message is received at the station for transmission. "NFT" in a preamble means no filing time.

(f) Every message shall bear a "date" and this date is transmitted by each station handling the message. The date is the "day filed" at the originating station unless otherwise specified by the sender.

(g) The "address" refers to the name, street and number, city, state, and telephone number of the party to whom the message is being sent. A *very complete address* should always be given to insure delivery. When accepting messages this point should be stressed. In transmitting the message the address is followed by a double dash or break sign (— · · · —) and it always precedes the text.

(h) The "text" consists of the words in the body of the message. No abbreviations should ever be substituted for the words in the text of the message. The text follows the address and is set off from the signature by another break (— · · · —).

(i) The "signature" is usually the name of the person sending the message. When no signature is given it is customary to include the words "no sig" at the end of the message to avoid confusion and misunderstanding. When there is a signature, it follows the break; the abbreviation "sig" is not transmitted.

The presence of unnecessary capital letters, periods, commas or other marks of punctuation may alter the meaning of a text. For this reason commercial communication companies use a shiftless typewriter (capitals only). The texts of messages are typed in block letters (all capitals) devoid of punctuation, underlining and paragraphing, except where expressed in words. In all communication work, accuracy is

of first importance. Spell out figures and punctuation.

Numbering Messages

Use of a "number sheet" or consecutive list of numbers enables any operator to tell quickly just what number is "next." Numbers may be crossed off as the messages are filed for origination. Another method of use consists of filing messages in complete form *except for the number*. Then the list of numbers is consulted and numbers assigned as each message is sent. As the operator you work acknowledges (QSLs) each message cross off the number used and note the call of the station and the date opposite this number.

The original number supplied each message by the operator at the originating station is transmitted by each station handling the message. No new numbers are given the message by intermediate stations.

Checking Traffic — The Land Line Check

The A.R.R.L. check is the land line or "text-only" count, consisting of the count of only the words in the body or text of the message. It is quicker and easier to count in this fashion than to use the cable count of words in address, text and signature check which is followed in marine operating work, this simplification being the reason for its adoption. When in the case of a few exceptions to the basic rule in land line checking, certain words in address, signature or preamble are counted, they are known as extra words, and all such are so designated in the check right after the total number of words.

Counting Words in Messages

The check includes: (1) all words, figures and letters in the body, and (2) the following extra words:

(a) Signatures except the first, when there are more than one (a title with signature does not count extra; but an address following a signature does).

(b) Words "report delivery," or "rush" in the check.

(c) Alternative names and/or street addresses, and such extras as "personal" or "attention -----."

Examples: "Mother, Father, James and Henry" is a family signature, no names counted extra. "John Brown, Second Lieutenant" or "Richard Johnson, Secretary Albany Auto Club" are each one signature with no words counted as extra. An official title or connection is part of one signature, not extra. "Technical Department, Lamb, Grammer and Mix" as a signature would count three extra words, those italicized after the first name counting as extras. The check of a message

The Radio Amateur's Handbook

with ten words text and three such extras in the signature would be "CK 13 3 extra."

Dictionary words in most languages count as one word irrespective of length of the word. In counting figures, a group of five digits or less will count as *one word*. Bars of division and decimal points may constitute one or more of the digits in such a group. It is recommended that, where feasible, words be substituted for figures to reduce the possibility of error in transmission. Detailed examples of word counting are about as difficult in one system of count as another.

Count as words dictionary words taken from English, German, French, Spanish, Latin, Italian, Dutch and Portuguese languages; initial letters, surnames of persons, names of countries, cities and territorial subdivisions. Abbreviations as a rule should be used only in service messages. Complete spelling of words is one way to avoid error. Contractions such as "don't" should be changed to "do not." Examples:

Emergency (English dictionary)	1 word
Nous arriverrons dimanche (French dictionary)	3 words
DeWitt (surname)	1 word
E.L.B.D. (initials)	4 words
United States (country)	1 word
President Hoover (steamship)	1 word
Prince William Sound	3 words
M.S. City of Belgrade (motor ship)	2 words

EXCEPTIONS

A.M., P.M.	1 word
F.O.B. (or fob)	1 word
O.K.	1 word
Per cent (or percent)	1 word

The best practice is to spell out all such when it is desired to send them in messages. In groups consisting of letters and figures *each* letter and figure will count as one word. The one exception to this is that amateur call signals sent as a group count as one word. In ordinal numbers, affixes d, nd, rd, st, and th count as one word. Abbreviations of weights and measures in common use count as one word each. Examples:

10 000 000 (figures)	2 words
Ten millions (dictionary words)	2 words
5348 (figures)	1 word
67.98 (figures)	1 word
64A2	1 word
45¼ (figures and bar of division)	1 word
3rd (ordinal number and affix)	2 words
W1BD1	1 word

Groups of letters which are not dictionary words of one of the languages enumerated, or combinations of such words will count at the rate of five letters or fraction thereof to a word. In the case of combinations each dictionary word so combined will count as a word. In addition USS USCG, etc., written and sent as compact letter-groups count as one word. Examples:

Tyfa (artificial 5 letter group)	1 word
Adecol (artificial 6 letter group)	2 words
alright, alright (improperly combined)	2 words
Dothe (improperly combined)	2 words
ARRL	1 word

At the request of sender the words "report back delivery" asking for a service showing success or failure in delivering at the terminal station, may be inserted after the check of "rush" or "get answer" similarly, such words counting as extras in the group or check designation as just covered by example. "Phone" or "Don't Phone" or other sender's instructions in the address are not counted as extra words. In transmitting street addresses where the words east, west, north or south are part of the address, spell out the words in full. Suffixes "th," "nd," "st," etc., should not be transmitted. Example: Transmit "19 W 9th St" as "19 West 9 St." "F St NE" should be sent, "F St Northeast." When figures and a decimal point are to be transmitted, add the words CNT DOT in the check.

Isolated characters each count as one word. Words joined by a hyphen or apostrophe count as separate words. Such words are sent as two words, without the hyphen. A hyphen or apostrophe each counts as one word. However, they are seldom transmitted. Two quotation marks or parenthesis signs count as one word. Punctuation is *never* sent in radio messages except at the express command of the sender. *Even then it is spelled out.*

Here is an example of a plain language message in correct A.R.R.L. form carrying the land line check:

NR 601 W1AW CK 9 WEST HARTFORD CONN
1R15P OCT 28

ALL RADIO HAMS
9 COMPLETE ADR ST
ANYCITY USA

ALL AMATEURS ARE REQUESTED TO FOLLOW
STANDARD ARRL FORM

HANDY ARRL CM

Message handling is one of the major things that lies in our power as amateurs to do to show our amateur radio in a respected light, rather than from a novelty standpoint. Regardless of experimental, QSL-collecting, friendly ragchews, and DX objectives, we doubt if the amateur exists who does not want to know how to phrase a message, how to put the preamble in order, how to communicate wisely and well when called upon to do so. Scarcely a month passes but what some of us in some section of our A.R.R.L. are called upon to add to the communication service record of the amateur.

It is important that deliveries be made in business-like fashion to give the best impression, and so that in each case a new friend

Operating the Station

and booster for amateur radio may be won. Messages should be typed or neatly copied, preferably on a standard blank, retaining original for the F.C.C. station file where these are mailed. The designation and address of the delivering station should be plainly given so a reply can be made by the same route if desired.

For those who would disparage some message texts as unimportant, perhaps a reminder is in order that in the last analysis it is not the importance to the ham that handles it that counts, but the importance to the party that sends and the party that receives a message.

The individual handling of traffic in quantities small as well as large is to a very great extent the material that we amateurs use for developing our operating ability, for organizing our relay lines, for making ourselves such a very valuable asset to the public and our country in every communications emergency that comes along, not to mention the individual utility and service performed by each message passed in normal amateur communications.

For those "breaking-in" may we say that any O.R.S., Trunkliner or experienced A.R.R.L. traffic handler will be very pleased to answer your questions and give additional pointers both in procedure and concerning your station set-up to help you make yours a really effective communications set-up. Since experience is the only real teacher we conclude by suggesting to all and sundry that becoming proficient in any branch of the game is partly just a matter of practice. Start a few messages, to get accustomed to the form. Check some messages to become familiar with the official A.R.R.L. (land line) check. You will find increased enjoyment in this side of amateur radio by adding to your ability to perform; by your familiarity with these things the chance of being able to serve your community or country in emergency will be greater. Credit will be reflected on amateur radio as a whole thereby.

Originating Traffic

Messages to other amateurs are a natural means of exchanging comment and maintaining friendships. The simplest additional way to get messages is to offer to send a few for friends, reminding them that the message service is free and no one can be held responsible for delay or non-delivery. Wide-awake amateurs have distributed message blanks to tourist camps. Lots of good traffic has been collected through a system of message-collection boxes placed in public buildings and hospitals. A neatly typed card should be displayed near-by explaining the workings of our A.R.R.L. traffic organization, and *listing the points to which the best possible service can be given.*

Messages that are not complete in every respect *should not be accepted* for relaying.

Complete address on every message is important.

To properly represent amateur radio, placards when used should avoid any possible confusion with telegraph and cable services. Any posters should refer to AMATEUR RADIOGRAMS, and explain that messages are sent through AMATEUR RADIO STATIONS, as a HOBBY, FREE, without cost (since amateurs can't and will not accept compensation). The exact conditions of the service should be stated or explained as completely as possible, including the fact that there is NO GUARANTEE OF DELIVERY. The individual in charge of the station has full powers to refuse any traffic unsuitable for radio transmission, or addressed to points where deliveries cannot be made. Relaying is subject to radio conditions and favorable opportunity for contacting. Better service can be expected on 15-word texts of *apparent importance* than on extremely long messages. Traffic should *not* be accepted for "all over the world."

Careful planning and organized schedules are necessary if a *real* job of handling traffic is to be done. Advance schedules are essential to assist in the distribution of messages. It may be possible to schedule stations in cities to which you know quantities of messages will be filed. Distribute messages, in the proper directions, widely enough so that a few outside stations do not become seriously overburdened. Operators must route traffic properly — not merely aim to "clear the hook."

It is better to handle a small or moderate volume of traffic *well* than to attempt to break records in a manner that results in delayed messages, non-deliveries, and the like which certainly cannot help in creating any public good-will for amateur radio.

Whatever type of exhibit is planned, write A.R.R.L. in advance, in order to receive sample material to make your amateur booth more complete. A *portable* station can be installed and operated, by an already licensed amateur subject to F.C.C. notification of location, etc., as provided by regulations. No license coverage is needed if no station is operated, of course.

Relay Procedure

Messages shall be relayed to the station nearest the location of the addressee and over the greatest distance permitting reliable communication.

No abbreviations shall be substituted for the words in the text of a message with the exception of "service messages," to be explained. Delivering stations must be careful that no confusing abbreviations are written into delivered messages.

Sending "words twice" is a practice to

The Radio Amateur's Handbook

avoid. Use it only when expressly called for by the receiving operator when receiving conditions are poor.

Messages shall be transmitted as many as three times at the request of the receiving operator. Failing to make a complete copy after three attempts, the receiving operator shall cancel the message (QTA).

Agreement to handle (relay or deliver) a message properly and promptly is always tacitly implied in accepting traffic. When temporarily *not* in a position to so handle, it is a service to amateur radio and your fellow ham to courteously *refuse* a message.

An operator with California traffic does not hear any western stations so he decides to give a directional "CQ" as per A.R.R.L. practice. He calls, CQ, CALIF CQ CALIF DE W11NF W11NF W11NF, repeating the combination three times.

He listens and hears W9CXX in Cedar Rapids calling him, W11NF W11NF W11NF DE W9CXX W9CXX W9CXX AR.

Then he answers W9CXX indicating that he wishes him to take the message. W11NF says W9CXX W9CXX DE W11NF R QSP MILL VALLEY CALIF NEAR SF? K.

After W9CXX has given him the signal to go ahead, the message is transmitted, thus:

HR MSG NR 78 W11NF CK15 WEST HARTFORD
CONN NFT (for "no filing time") NOV 18

ALAN D WHITTAKER JR W6SG
79 ELINOR AVE
MILL VALLEY CALIF

SUGGEST YOU USE ARRL TRUNK LINE K
THROUGH W5NW TO HANDLE PROPOSED VOL-
UME TRAFFIC REGARDS

BUBB W1JTD

W9CXX acknowledges the message like this: W11NF DE W9CXX NR 78 R. K. Not a single R should be sent unless the whole message has been correctly received.

Full handling data is placed on the message for permanent record at W11NF. The operator at W9CXX has now taken full responsibility for doing his best in forwarding the message.

Fixed Text Messages — ARL Check

To start a fixed text message, the originator must select one of the texts from a list. The amateur starting the message sends the *number* corresponding to that particular text instead of the text. The letters ARL (short for American-Radio-Relay-League-numbered-text-to-follow) must be placed before the figures of the check to show that the text is from our particular numbered text list. "ARL" identifies this at once as a message that has to be expanded for delivery or relaying to a station that has no list (to have complete understanding and avoid error). In radio handling the number must always be spelled out, for accuracy.

The new list of "A.R.R.L. Numbered Radiograms" is in the possession of every member of the League's Emergency Corps, and every O.R.S., O.P.S., and field organization official. The list of fixed texts was prepared mainly with possible emergency needs and utility in mind; it is a special tool for special occasions. It may be used *only* when stations at each end of a QSO are equipped with exactly similar lists. Extra precautions to insure accuracy are necessary when using a number for a text; every message delivered or relayed to a station not having a list must be completely expanded.

The new list of sixty texts will be sent free of charge to anyone requesting it by sending a radiogram asking for it. We want the list to be available to anyone active in amateur traffic handling or likely to have a use for it. We shall continue to recommend the use of *individually worded messages* instead of any stereotyped form in every case possible. Use "numbered texts" with caution, only with other operators with experience and similar lists. But all stations might well keep a copy of the new list ready *in the station log*.

Example: NR1 W1AW CK ARL1 Newington Conn
March 2 (Address) BT THREE BT John AR

"ARL?" can readily be understood to mean, "Do you have the list of A.R.R.L.-Numbered Radiograms, and are you ready for such a message," "ARL" (reply) then means, "I have the A.R.R.L.-Numbered Radiogram list. I am ready for such a message."

A list of the texts applicable to possible relief-emergency uses follows:

ONE	All safe. Do not be concerned about disaster reports.
TWO	Coming home as soon as possible.
THREE	Am perfectly all right. Don't worry.
FOUR	Everyone safe here. Only slight property damage.
FIVE	All well here. Love to folks.
SIX	Everyone safe, writing soon.
*SEVEN	Reply by amateur radio.
EIGHT	All safe, writing soon, love.
NINE	Come home at once.
TEN	Will be home as soon as conditions permit.
ELEVEN	Cannot get home. Am perfectly all right. Will be home as soon as conditions permit.
*TWELVE	Are you safe? Anxious to hear from you.
*THIRTEEN	Is safe? Anxious to hear.
*FOURTEEN	Anxious to know if everything is OK. Please advise.
*FIFTEEN	Advise at once if you need help.
*SIXTEEN	Please advise your condition.
*SEVENTEEN	Kindly get in touch with us.
*EIGHTEEN	Please contact me as soon as possible (at).

None of these numbered-text messages should be handled in the *first stages* of any general emergency. Those marked above with an asterisk (*) should never be *solicited* during an emergency, since experience shows that such

Operating the Station

Delivering Messages

Provisions of the Radio Act of 1934 make it a misdemeanor to give out information of any sort to any person except the addressee of a message. It is in no manner unethical to deliver an unofficial copy of a radiogram, if you carefully mark it *duplicate* or *unofficial copy* and do it to improve the speed of handling a message or to insure certain and prompt delivery. Do not forget that there are heavy fines prescribed by Federal laws for divulging the contents of messages to anyone *except* the person addressed in a message.

When it is possible to deliver messages in person, that is usually the most effective way. When the telephone does not prove instrumental in locating the party addressed in the message it is usually quickest to mail the message.

A.R.R.L. delivery rules:

Messages received by stations shall be delivered immediately.

Every domestic message shall be relayed within forty-eight (48) hours after receipt or if it cannot be relayed within this time shall be mailed to the addressee.

Messages for points outside North America must not be held longer than half the length of time required for them to reach their destination by mail.

When a message cannot be delivered, or if it is unduly delayed, a "service" message should be written and started back to the "office of origin."

Each operator who reads these pages is asked to assume *personal responsibility* for accuracy, speed of each message handled and delivery that we may approach a 100% delivery figure.

The Service Message

A service message is a message sent by one station to another station relating to the service which we are or are not able to give in message handling. The service message may refer to non-deliveries, to delayed transmission, errors, or to any phase of message handling activity. It is not proper to abbreviate words in the texts of regular messages, but it is quite desirable and correct to use abbreviations in these station-to-station messages relating to traffic-handling work. Example:

HR SVC NR 291 W3CA CK XX ROANOKE VA NPT
AUG 19
LC MAYBEE W7GE
110 SOUTH SEVENTH AVE
PASCO WASHN — — — —
UR NR 87 AUG 17 TO CUSHING SIG BOB HELD
HR UNDL D PSE GBA — — — —
WOHLFORD W3CA

Counting Messages

To compare the number originated and delivered each month to learn some facts about the "efficiency" of our work in handling mes-

inquiry traffic going into an emergency area ordinarily cannot be delivered while the emergency still exists. Concentration must be on traffic going out of an emergency area.

Never forget to put "ARL" in the check — or the delivering station will deliver a "number" instead of the words it stands for. From the table we see that the text in the example must be completely written out as AM PERFECTLY ALL RIGHT. DON'T WORRY. when it is delivered, or transmitted to any station without a list, or that cannot make affirmative response to "ARL?"

Getting Fills

If the first part of a message is received but substantially all of the latter portions lost, the request for the missing parts is simply *RPT TXT AND SIG*, meaning "Repeat text and signature." *PBL* and *ADR* may be used similarly for the preamble and address of a message. *RPT AL* or *RPT MSG* should not be sent unless nearly all of the message is lost.

Each abbreviation used after a question mark (· — — ·) asks for a repetition of that particular part of a message.

When a few word-groups in conversation or message handling have been missed, a selection of one or more of the following abbreviations will enable you to ask for a repeat on the parts in doubt. Phone stations of course request fills by using the full wording specified, without attempt at abbreviation.

Abbreviation	Meaning
?AA.....	Repeat all after.....
?AB.....	Repeat all before.....
?AL.....	Repeat all that has been sent
?BN...AND.....	Repeat all between...and....
?WA.....	Repeat the word after.....
?WB.....	Repeat the word before.....

The good operator will ask for only what fills are needed, separating different requests for repetition by using the break sign or double dash (— · · —) between these parts. There is seldom any excuse for repeating a whole message just to get a few lost words.

Another interrogation method is sometimes used, the question signal (· · — — · ·) being sent between the last word received correctly and the first word (or first few words) received after the interruption. *RPT FROM TO* is a long way of asking for fills which we have heard used by beginners.

The figure four (· · · —) is a time-saving abbreviation which deserves popularity with traffic men. It is another of those hybrid abbreviations whose original meaning, "Please start me, where?" has come to us from Morse practice. Of course *?AL* or *RPT AL* will serve the same purpose, where a request for a repetition of parts of a message has been missed.

The Radio Amateur's Handbook

A.R.R.L.—AMERICAN RED CROSS UNDERSTANDING

The purpose of this understanding between the American Red Cross and the American Radio Relay League is to secure maximum co-operation in time of disaster. The Board of Directors of the American Radio Relay League at its meeting June 1, 1940, considered the relationships of the American amateur radio fraternity with the American Red Cross in time of disasters involving disruption of communication.

The American Radio Relay League recognizes the American Red Cross as the agency chartered by Congress to represent the American people in carrying on disaster relief and therefore as the primary agency.

The American Red Cross recognizes that the amateur radio service, because of its excellent geographical station coverage, and especially the available stations possessing emergency power supply, can render valuable aid in re-establishing communication when other facilities have been disrupted.

The American Red Cross welcomes the co-operation of the American Radio Relay League with local Red Cross chapters to extend radio planning into chapter jurisdictions and to correlate amateur radio operations to assure the best possible communications by such facilities. This co-operation with American Red Cross chapters may be furthered by individual chapters' designation of an American Radio Relay League Emergency Coordinator to serve as a member of the Red Cross Chapter Sub-Committee on Transportation and Communication as recommended in the Chapter Disaster Preparedness & Relief Manual, ARC 209.

sages, a method of counting is used. Each time a message is *handled by radio* it counts one in the total.

A message received in person, by telephone, by telegraph, or by mail, *filed at the station and transmitted by radio* in proper form, counts as *one originated*.

A message *received by radio and delivered* in person, by telephone, telegraph, or mail, counts as *one delivered*.

A message *received by radio and sent forward by radio* counts as two messages *relayed* (one when received and again one when sent forward).

A "service" message counts the same as any other type of message.

In addition to the basic count of *one* for each time a message is handled by radio, an *extra credit* of one point for each delivery made by mail, telephone, in person, by messenger or other external means *other than use of radio* (which would count as a "relay" of course) will also be allowed. A message received by an operator for himself or his station or party on the immediate premises counts *only* "one delivered." A message for a third party delivered by *additional means or effort* will receive a point under "extra delivery credits."

The message total shall be the sum of the messages originated, delivered and relayed and the "extra" delivery credits. Each station's message file and log shall be used to determine the report submitted by that particular station. Messages with identical texts (so-called rubber-stamp messages) shall count once only for each time the complete text, preamble and signature are sent by radio.

League Operating Organization

Your A.R.R.L. arranges amateur operating activities, promotes preparation and organization for communications emergencies, establishes procedure to aid efficient operation, encourages good operating and maintains a strong field organization. The Communications Department of the League is concerned with the practical operation of stations in all branches of amateur activity. Appointments and awards are available for rag chewer, 'phone operator, traffic enthusiast and DX man. It is the League's policy to benefit each group concerned along lines of natural interest. All activities have specific objectives with widest participation invited. This insures maximum fun and benefit to the whole fraternity.

Whether your activity is directed toward 'phone or telegraph, there is a place for you in League organization.

We live in an age of specialization, and A.R.R.L. appointees specialize in particular branches of amateur operation for which they have special interest, aptitude or equipment. The voluntary acceptance of organization appointment carries prestige. It is a symbol of the mature, serious, accomplished amateur. Appointment also entitles the individual to certain bulletins that carry the first facts on new items of legislation and regulation as well as reports on activity and operating announcements. Every amateur should aim to become and remain a *member* of the League, and take an active part in his society and field organization work. There is fun and profit in doing this.

Complete information on all appointments and League awards for working all states (WAS), working all countries (WAC), the DX Century Club, etc., is included in the booklet, "Operating an Amateur Radio Station." Members of the League may obtain a copy free upon request; to others, a charge of 10 cents is made.

Bibliography

- ¹ Plans for Emergency Operating, page 35, April, 1938, QST.
- ² What Will Be Expected of Amateurs — The F.C.C. Emergency Regulations, page 71, February, 1939, QST.
- ³ All Amateurs Invited to Join the A.R.R.L. Emergency Corps — Western Union Collaborates in Registrations, page 45, June, 1939, QST.

Regulations and Data

"Q" Code — Abbreviations — Country List — Amateur Regulations

IN THE REGULATIONS accompanying the existing International Radiotelegraph Convention there is a very useful internationally-agreed code designed to meet major needs in international radio communication. This code follows. The abbreviations themselves have the meanings shown in the "answer" column. When an abbreviation is followed by an interrogation mark (?) it assumes the meaning shown in the "question" column.

Abbreviation	Question	Answer
QRA	What is the name of your station?	The name of my station is
QRB	How far approximately are you from my station?	The approximate distance between our stations is nautical miles (or kilometers).
QRC	What company (or Government Administration) settles the accounts for your station?	The accounts for my station are settled by the company (or by the Government Administration of).
QRD	Where are you bound and where are you from?	I am bound for from
QRC	Will you tell me my exact frequency (wave-length) in kc/s (or m)?	Your exact frequency (wave-length) is kc/s (or m).
QRH	Does my frequency (wave-length) vary?	Your frequency (wave-length) varies.
QRI	Is my note good?	Your note varies.
QRJ	Do you receive me badly? Are my signals weak?	I cannot receive you. Your signals are too weak.
QRK	What is the legibility of my signals (1 to 5)?	The legibility of your signals is (1 to 5).
QRL	Are you busy?	I am busy (or I am busy with). Please do not interfere.
QRM	Are you being interfered with?	I am being interfered with.
QRN	Are you troubled by atmospherics?	I am troubled by atmospherics.
QRO	Shall I increase power?	Increase power.
QRP	Shall I decrease power?	Decrease power.
QRQ	Shall I send faster?	Send faster (. words per minute).
QRS	Shall I send more slowly?	Send more slowly (. words per minute);
QRT	Shall I stop sending?	Stop sending.
QRU	Have you anything for me?	I have nothing for you.
QRV	Are you ready?	I am ready.
QRW	Shall I tell that you are calling him on kc/s (or m)?	Please tell that I am calling him on kc/s (or m).
QRX	Shall I wait? When will you call me again?	Wait (or wait until I have finished communicating with) I will call you at o'clock (or immediately).
QRY	What is my turn?	Your turn is No. (or according to any other method of arranging it).
QRZ	Who is calling me?	You are being called by
QSA	What is the strength of my signals (1 to 5)?	The strength of your signals is (1 to 5).
QSB	Does the strength of my signals vary?	The strength of your signals varies.
QSD	Is my keying correct; are my signals distinct?	Your keying is incorrect; your signals are bad.
QSC	Shall I send telegrams (or one telegram) at a time?	Send telegrams (or one telegram) at a time.
QSJ	What is the charge per word for including your internal telegraph charge?	The charge per word for is francs, including my internal telegraph charge.
QSK	Shall I continue with the transmission of all my traffic, I can hear you through my signals?	Continue with the transmission of all your traffic, I will interrupt you if necessary.
QSL	Can you give me acknowledgment of receipt?	I give you acknowledgment of receipt.
QSM	Shall I repeat the last telegram I sent you?	Repeat the last telegram you have sent me.
QSO	Can you communicate with direct (or through the medium of)?	I can communicate with direct (or through the medium of).
QSP	Will you retransmit to free of charge?	I will retransmit to free of charge.
QSR	Has the distress call received from been cleared?	The distress call received from has been cleared by
QSU	Shall I send (or reply) on kc/s (or m) and/or on waves of Type A1, A2, A3, or B?	Send (or reply) on kc/s (or m) and/or on waves of Type A1, A2, A3, or B.
QSV	Shall I send a series of VVV?	Send a series of VVV

The Radio Amateur's Handbook

Abbreviation	Question	Answer
QSW	Will you send on kc/s (or m) and/or on waves of Type A1, A2, A3, or B?	I am going to send (or I will send) on kc/s (or m) and/or on waves of Type A1, A2, A3, or B.
QSX	Will you listen for (call sign) on kc/s (or m)?	I am listening for (call sign) on kc/s (or m).
QSY	Shall I change to transmission on kc/s (or m) without changing the type of wave? or Shall I change to transmission on another wave?	Change to transmission on kc/s (or m) without changing the type of wave or Change to transmission on another wave.
QSZ	Shall I send each word or group twice?	Send each word or group twice.
QTA	Shall I cancel telegram No. as if it had not been sent?	Cancel telegram No. as if it had not been sent.
QTB	Do you agree with my number of words?	I do not agree with your number of words; I will repeat the first letter of each word and the first figure of each number.
QTC	How many telegrams have you to send?	I have telegrams for you (or for).
QTE	What is my true bearing in relation to you? or What is my true bearing in relation (call sign)? or What is the true bearing of (call sign) in relation to (call sign)?	Your true bearing in relation to me is degrees or Your true bearing in relation to (call sign) is degrees at (time) or The true bearing of (call sign) in relation to (call sign) is degrees at (time).
QTF	Will you give me the position of my station according to the bearings taken by the direction-finding stations which you control?	The position of your station according to the bearings taken by the direction-finding stations which I control is latitude longitude.
QTC	Will you send your call sign for fifty seconds followed by a dash of ten seconds on kc/s (or m) in order that I may take your bearing?	I will send my call sign for fifty seconds followed by a dash of ten seconds on kc/s (or m) in order that you may take my bearing.
QTH	What is your position in latitude and longitude (or by any other way of showing it)?	My position is latitude longitude (or by any other way of showing it).
QTI	What is your true course?	My true course is degrees.
QTJ	What is your speed?	My speed is knots (or kilometers) per hour.
QTM	Send radioelectric signals and submarine sound signals to enable me to fix my bearing and my distance.	I will send radioelectric signals and submarine sound signals to enable you to fix your bearing and your distance.
QTO	Have you left dock (or port)?	I have just left dock (or port).
QTP	Are you going to enter dock (or port)?	I am going to enter dock (or port).
QTQ	Can you communicate with my station by means of the International Code of Signals?	I am going to communicate with your station by means of the International Code of Signals.
QTR	What is the exact time?	The exact time is
QTU	What are the hours during which your station is open?	My station is open from to
QUA	Have you news of (call sign of the mobile station)?	Here is news of (call sign of the mobile station).
QUB	Can you give me in this order, information concerning: visibility, height of clouds, ground wind for (place of observation)?	Here is the information requested
QUC	What is the last message received by you from (call sign of the mobile station)?	The last message received by me from (call sign of the mobile station) is
QUD	Have you received the urgency signal sent by (call sign of the mobile station)?	I have received the urgency signal sent by (call sign of the mobile station) at (time).
QUF	Have you received the distress signal sent by (call sign of the mobile station)?	I have received the distress signal sent by (call sign of the mobile station) at (time).
QUG	Are you being forced to alight in the sea (or to land)?	I am forced to alight (or land) at (place).
QUH	Will you indicate the present barometric pressure at sea level?	The present barometric pressure at sea level is (units).
QUJ	Will you indicate the true course for me to follow, with no wind, to make for you?	The true course for you to follow, with no wind, to make for me is degrees at (time).
QUK	Can you tell me the condition of the sea observed at (place or coördinates)?	The sea at (place or coördinates) is
QUL	Can you tell me the swell observed at (place or coördinates)?	The swell at (place or coördinates) is
QUM	Is the distress traffic ended?	The distress traffic is ended.

Special abbreviations adopted by the A.R.R.L.:

QST General call preceding a message addressed to all amateurs and A.R.R.L. Members. This is in effect "CQ ARRL."

QRR Official A.R.R.L. "land SOS." A distress call for use by stations in emergency zones only.

Regulations and Data

Scales Used in Expressing Signal Strength and Readability

(See QRK and QSA in the Q Code)

<i>Strength</i>	<i>Readability</i>
QSA1.....Barely perceptible	QRK1.....Unreadable
QSA2.....Weak	QRK2.....Readable now and then
QSA3.....Fairly good	QRK3.....Readable with difficulty
QSA4.....Good	QRK4.....Readable
QSA5.....Very good	QRK5.....Perfectly readable

● ABBREVIATIONS

In amateur work many frequently-used words are abbreviated. Many of these abbreviations have the sanction of international regulations but others come from the old press codes and many have been made by amateurs themselves. Together, with the "Q Code," they constitute a miniature language frequently called "QST English," from the name of the A.R.R.L.'s magazine. We list below the more frequently encountered abbreviations. While some are purely arbitrary, it will be noted that some are simple phonetic spellings, others are the first and last letters of a word, some simply eliminate vowels, some use the letter *x* to replace part of a word, etc.

AA	All after (to be used after a ? to ask for a repetition).	FB	Fine business, excellent
AB	All before (to be used after a ? to ask for a repetition).	FD	A.R.R.L. Field Day
AL	All that has just been sent (to be used after a ? to ask for a repetition).	FIL	Filament
BN	All between (to be used after a ? to ask for a repetition).	FM	From
ABT	About	FONES	Telephones
ACCT	Account	FR	For
ADR	Address	FREQ	Frequency
AGN	Again	GA	Go ahead (resume sending)
AMP	Ampere	GB	Good-bye
AMT	Amount	GBA	Give better address
ANI	Any	GE	Good evening
BCL	Broadcast listener	GG	Going
BCNU	Be seeing you	GM	Good morning
BD	Bad	GN	Gone, good night
BK	Break	GND	Ground
BLV	Believe	GSA	Give some address
BN	Been, all between	HAM	Amateur, brass-pounder
BPL	Brass Pounders' League	HBN	Have been, has been
BTN	Between	HI	Laughter, high
BUG	Vibroplex key	HR	Here, hear
C	Yes	HRD	Heard
CANS	Phones	HV	Have
CFM	Confirm (or I confirm)	ICW	Interrupted continuous wave
CK	Check	JM	If I may transmit, send a series of dashes. To stop my transmission, send a series of dots.
CKT	Circuit	LID	"Lid," a poor operator
CL	Closing station; call	LTR	Later, letter
CLD	Called	MA	Milliampere
CM	Communications Manager	MG	Motor-generator
CRD	Card	MILS	Milliamperes
CD-CUD	Could	MSG	Message
CUL	See you later	ND	Nothing doing
CW	Continuous wave	NIL	Nothing
DH	Dead head	NM	No more
DLV-DLVD	Delivered	NR	Number, near
DLY	Delivery	NSA	No such address
DX	Distance	NW	Now
ES	And	OB	Old Boy, Official Broadcast
		OC	Old chap
		OM	Old Man
		OO	Official Observer
		OPN	Operation
		OPS	Official 'Phone Station
		OP-OPR	Operator
		ORS	Official Relay Station
		OT	Old timer, old top
		OW	Old woman
		PBL	Preamble
		PP	Push-pull
		PSE	Please
		PUNK	Poor operator
		PX	Press
		R	Are, all right, O.K.
		RAC	Rectified alternating current
		RCD	Received
		RCVR	Receiver
		RDO	Radio
		RI	Radio Inspector
		RM	Route Manager
		RPT	Repeat
		SA	Say
		SCM	Section Communications Manager
		SED	Said
		SEZ	Says

The Radio Amateur's Handbook

SIG	Signature
SIGS	Signals
SINE	Sign, personal initials
SKED	Schedule
SS	A.R.R.L. Sweepstakes Contest
SVC	Service
TFC	Traffic
TKS-TNX-TU	Thanks
TNG	Thing
TMW	Tomorrow
TT	That
U	You
UR	Your, you're
URS	Yours
VT	Vacuum tube
VY	Very
WA	Word after (to be used after a ? to request a repetition).
WB	Word before (to be used after a ? to request a repetition).
WD	Would, word
WDS	Words
WKD	Worked
WKG	Working
WL	Will
WT	What, wait, watt
WUD	Would
WX	Weather
XMTR	Transmitter
XYL	Wife
YF	Wife
YL	Young lady
YS	Your service message
73	Best regards
88	Love and kisses

● PREFIXES

Alaska	K7
Antarctica	KC4
Baker Island, Howland Island, Am. Phoenix Islands	KF6
Canal Zone	K5, NY1, NY2
Guam	KB6
Guantanamo	NY4
Hawaiian Islands	K6
Jarvis Island, Palmyra Group	KG6
Johnston Island	KE6
Midway Island	KD6
Philippine Islands	KA
Puerto Rico	K4
Samoa, American	KH6
Swan Island	KD4
United States	W [N]
Virgin Islands	KB4
Wake group	KC6

● UNITED STATES AMATEUR REGULATIONS

Pursuant to the basic communications law, general regulations for amateurs have been drafted by the Federal Communications Commission. The number before each regulation is its official number in the complete book of regulations for all classes of radio stations as issued by the Commission; the number of each regulation is of no consequence to the amateur, except as a means of reference.

These regulations are correct as of October 1, 1940. As the regulations are subject to change from time to time, it is recommended that *The Radio Amateur's License Manual* (25¢ postpaid, from the A.R.R.L.) be consulted for latest official regulations, since it is always kept

up-to-date either by frequent revisions or by the inclusion of a "change-sheet" giving necessary corrections. It is not expected that any changes of importance will have been made during 1940 but if studying for a license it is best to take no chances, and the *License Manual* should always be consulted for the text of regulations in such cases.

GENERAL REGULATIONS APPLICABLE TO AMATEURS

1.71. *Applications made on prescribed forms.* Each application for an instrument of authorization shall comply with the Commission's Rules and Regulations and shall be made in writing . . . on a form furnished by . . . the Commission. . . . Separate application shall be filed for each instrument of authorization requested. . . . The required forms may be obtained from the Commission or from any of its field offices. (For a list of such offices and related geographical districts see the table following these regulations.)

1.351. *Place of filing; number of copies.* Each application for . . . station license . . . with respect to the number of copies and place of filing, shall be submitted as follows: . . . g. Amateur: 1 copy to be sent as follows: (a) To proper district office if it requires personal appearance for operator examination under direct supervision from that office; (b) direct to Washington, D. C., in all other cases, including examinations for Class C privileges.

1.359. *Modification of license.* . . . each application for modification of license shall be filed at least 60 days prior to the contemplated modification of license: *Provided, however*, That in emergencies and for good cause shown, the requirements hereof may be waived insofar as time for filing is concerned.

1.360. *Renewal of license.* Unless otherwise directed by the Commission, each application for renewal of license shall be filed at least 60 days prior to the expiration date of the license sought to be renewed.

1.391. *Answers to notices of violation.* Any licensee receiving official notice of a violation of the terms of the Communications Act of 1934, any legislative act, Executive order, treaty to which the United States is a party, or the Rules and Regulations of the Federal Communications Commission, shall, within 3 days from such receipt, send a written answer direct to the Federal Communications Commission at Washington, D. C., and a copy thereof to the office of the Commission originating the official notice when the originating office is other than the office of the Commission in Washington, D. C.: *Provided, however*, That if an answer cannot be sent nor an acknowledgment made within such 3-day period by reason of illness or other unavoidable circumstances, acknowledgment and answer shall be made at the earliest practicable date with a satisfactory explanation of the delay. The answer to each notice shall be complete in itself and shall not be abbreviated by reference to other communications or answers to other notices. If the notice relates to some violation that may be due to the physical or electrical characteristics of transmitting apparatus, the answer shall state fully what steps, if any, are taken to prevent future violations, and if any new apparatus is to be installed, the date such apparatus was ordered, the name of the manufacturer, and promised date of delivery. . . . If the notice of violation relates to some lack of attention or improper operation of the transmitter, the name and license number of the operator in charge shall be given.

1.401. *Revocation of station license.* Whenever the Commission shall institute a revocation proceeding against the holder of any radio station . . . license . . . it shall initiate said proceeding by serving upon said licensee an order of revocation effective not less than 15 days after written notice thereof is given the licensee. The order of revocation shall contain a statement of the grounds and reasons for such proposed revocation and a notice of the licensee's right to be heard by filing with the Commission a written request for hearing within 15 days after receipt of said order. Upon the filing of such written request for hearing by said licensee the order of revocation shall stand suspended and the Commission will set a time and place for hearing and shall give the licensee and other interested parties notice thereof. If no request for hearing on any order of revocation is made by the licensee against whom such an order is directed within the time hereinabove set forth, the order of revocation shall become final and effective, without further action of the Commission. When any order of revocation has become final, the person whose license has been revoked shall forthwith

Regulations and Data

deliver the station license in question to the inspector in charge of the district in which the licensee resides.

1.411. *Suspension of operator licenses: Order of suspension.* No order of suspension of any operator's license shall take effect until 15 days' notice in writing thereof, stating the cause for the proposed suspension, has been given to the operator licensee who may make written application to the Commission at any time within said 15 days for a hearing upon such order. The notice to the operator licensee shall not be effective until actually received by him, and from that time he shall have 15 days in which to mail the said application. In the event that physical conditions prevent mailing of the application at the expiration of the 15-day period, the application shall then be mailed as soon as possible thereafter, accompanied by a satisfactory explanation of the delay. Upon receipt by the Commission of such application for a hearing, said order of suspension shall be held in abeyance until the conclusion of the hearing which shall be conducted under such rules as the Commission shall deem appropriate. Upon the conclusion of said hearing the Commission may affirm, modify, or revoke said order of suspension.

1.412. *Suspension of operator licenses: Proceedings.* Proceedings for the suspension of an operator's license shall in all cases be initiated by the entry of an order of suspension. Respondent will be given notice thereof together with notice of his right to be heard and to contest the proceeding. The effective date of the suspension will not be specified in the original order but will be fixed by subsequent motion of the Commission in accordance with the conditions specified above. Notice of the effective date of suspension will be given respondent, who shall send his operator license to the office of the Commission in Washington, D. C., on or before the said effective date, or, if the effective date has passed at the time notice is received, the license shall be sent to the Commission forthwith.

2.45. *License expiration time and periods.* Each station license will be issued so as to expire at the hour 3 A.M. eastern standard time. The normal license periods and expiration dates are specified under the rules governing the class of station concerned. (See Sec. 12.64 of amateur regulations for amateur station-license period.)

2.48. *Station inspection.* The licensee of any radio station shall make the station available for inspection by representatives of the Commission at any reasonable hour and under the regulations governing the class of station concerned.

2.53. *Operators, place of duty.* (a) Except as may be provided in the rules governing a particular class of station, one or more licensed operators of the grade specified by these rules and regulations shall be on duty at the place where the transmitting apparatus of each station is located and in actual charge thereof whenever it is being operated; *Provided, however, That:* (1) Subject to the provisions of paragraph (b) of this section, in the case of a station licensed for service other than broadcast, where remote control is used, the Commission may modify the foregoing requirements upon proper application and showing being made so that such operator or operators may be on duty at the control station in lieu of the place where the transmitting apparatus is located. . . .

(b) Authority to employ an operator at the control point in accordance with paragraph (a) (1) of this section shall be subject to the following conditions:

(1) The transmitter shall be so installed and protected that it is not accessible to other than duly authorized persons.

(2) The emissions of the transmitter shall be continuously monitored at the control point by a licensed operator of the grade specified for the class of station involved.

(3) Provision shall be made so that the transmitter can quickly and without delay be placed in an inoperative condition in the event there is a deviation from the terms of the station license.

(4) The radiation of the transmitter shall be suspended immediately when there is a deviation from the terms of the station license.

2.59. *Distress messages.* Each station licensee shall give absolute priority to radio communications or signals relating to ships or aircraft in distress; shall cease all sending on frequencies which will interfere with hearing a radio communication or signal of distress. . . .

2.91. *Military or naval test communications.* The licensee of any radio station may, if proper notice from authorized government representatives is filed with and approved by the Commission, utilize such stations for military or naval test communications (messages not necessary for the conduct of ordinary governmental business) in preparation for national defense during the period or periods stated in said notice subject to the sole condition that no interference to

any service of another country will result therefrom. Nothing herein or in any other regulation of the Commission shall be construed to require any such station to participate in any such test.

AMATEUR REGULATIONS

DEFINITIONS

12.1. *Amateur service.* The term "amateur service" means a radio service carried on by amateur stations.

12.2. *Amateur station.* The term "amateur station" means a station used by an "amateur," that is, a duly authorized person interested in radio technique solely with a personal aim and without pecuniary interest. It embraces all radio transmitting apparatus at a particular location used for amateur service and operated under a single instrument of authorization.

12.3. *Amateur portable station.* The term "amateur portable station" means an amateur station that is portable in fact, that is so constructed that it may conveniently be moved about from place to place for communication, and that is in fact so moved from time to time, but which is not operated while in motion.

12.4. *Amateur portable-mobile station.* The term "amateur portable-mobile station" means an amateur station that is portable in fact, that is so constructed that it may conveniently be transferred to or from a mobile unit or from one such unit to another, and that is in fact so transferred from time to time and is ordinarily used while such mobile unit is in motion.

12.5. *Amateur radio communication.* The term "amateur radio communication" means radio communication between amateur stations solely with a personal aim and without pecuniary interest.

12.6. *Amateur operator.* The term "amateur operator" means a person holding a valid license issued by the Federal Communications Commission authorizing him to operate licensed amateur stations.

LICENSES; PRIVILEGES

12.21. *Eligibility for license.* The following are eligible to apply for amateur operator license and privileges:

Class A — A United States citizen who has within five years of receipt of application held license as an amateur operator for a year or who in lieu thereof qualified under Section 12.46.

Class B — Any United States citizen.

Class C — A United States citizen whose actual residence, address, and station, are more than 125 miles airline from the nearest point where examination is given at least quarterly for Class B; or is shown by physician's certificate to be unable to appear for examination due to protracted disability; or is shown by certificate of the commanding officer to be in a camp of the Civilian Conservation Corps or in the regular military or naval service of the United States at a military post or naval station and unable to appear for Class B examination.

12.22. *Classification of operating privileges.* Amateur operating privileges are as follows:

Class A — All amateur privileges.

Class B — Same as Class A except specially limited as in Section 12.114.

Class C — Same as Class B.

12.23. *Scope of operator authority.* Amateur operators licenses are valid only for the operation of licensed amateur stations; *provided, however,* any person holding a valid radio operator's license of any class may operate stations in the experimental service licensed for, and operating on, frequencies above 300,000 kilocycles.

12.24. *Posting of license.* The original operator's license shall be posted in a conspicuous place in the room occupied by such operator while on duty or kept in his personal possession and available for inspection at all times while the operator is on duty, except when such license has been filed with application for modification or renewal, or has been mutilated, lost, or destroyed, and application has been made for a duplicate.

12.25. *Duplicate license.* Any licensee applying for a duplicate license to replace an original which has been lost, mutilated, or destroyed, shall submit to the Commission such mutilated license or affidavit attesting to the facts regarding the manner in which the original was lost or destroyed. If the original is later found, it or the duplicate shall be returned to the Commission.

12.26. *Renewal of amateur operator license.* An amateur operator license may be renewed upon proper application and a showing that within three months of receipt of the application by the Commission the licensee has lawfully

The Radio Amateur's Handbook

operated an amateur station licensed by the Commission, and that he has communicated by radio with at least three other such amateur stations. Failure to meet the requirements of this section will make it necessary for the applicant to again qualify by examination.

12.27. *Who may operate an amateur station.* An amateur station may be operated only by a person holding a valid amateur operator's license, and then only to the extent provided for by the class of privileges for which the operator's license is endorsed. When an amateur station uses radiotelephony (type A-3 emission) the licensee may permit any person to transmit by voice, provided a duly licensed amateur operator maintains control over the emissions by turning the carrier on and off when required and signs the station off after the transmission has been completed.

EXAMINATIONS

12.41. *When required.* Examination is required for a new license as an amateur operator or for change of class of privileges.

12.42. *Elements of examination.* The examination for amateur operator privileges will comprise the following elements:

1. Code test — ability to send and receive, in plain language, messages in the International Morse Code at a speed of not less than thirteen words per minute, counting five characters to the word, each numeral or punctuation mark counting as two characters.
2. Amateur radio operation and apparatus, both telephone and telegraph.
3. Provisions of treaty, statute and regulations affecting amateurs.
4. Advanced amateur radiotelephony.

12.43. *Elements required for various privileges.* Examinations for Class A privileges will include all four examination elements as specified in Section 12.42.

Examinations for Classes B and C privileges will include elements 1, 2, and 3 as set forth in Section 12.42.

12.44. *Manner of conducting examination.* Examinations for Class A and Class B privileges will be conducted by an authorized Commission employee or representative at points specified by the Commission.

Examinations for Class C privileges will be given by volunteer examiner(s), whom the Commission may designate or permit the applicant to select; in the latter event the examiner giving the code test shall be a holder of an amateur license with Class A or B privileges, or have held within five years a license as a professional radiotelegraph operator or have within that time been employed as a radiotelegraph operator in the service of the United States; and the examiner for the written test, if not the same individual, shall be a person of legal age.

12.45. *Additional examination for holders of Class C privileges.* The Commission may require a licensee holding Class C privileges to appear at an examining point for a Class B examination. If such licensee fails to appear for examination when directed to do so, or fails to pass the supervisory examination, the license held will be canceled and the holder thereof will not be issued another license for the Class C privileges.

Whenever the holder of Class C amateur operator privileges changes his actual residence or station location to a point where he would not be eligible to apply for Class C privileges in the first instance, or whenever a new examining point is established in a region from which applicants were previously eligible for Class C privileges, such holders of Class C privileges shall within four months thereafter appear at an examining point and be examined for Class B privileges. The license will be canceled if such licensee fails to appear, or fails to pass the examination.

12.46. *Examination abridgment.* An applicant for Class A privileges, who holds a license with Class B privileges, will be required to pass only the added examination element, No. 4. (See Section 12.42.)

A holder of Class C privileges will not be accorded an abridged examination for either Class B or Class A privileges.

An applicant who has held a license for the class of privileges specified below, within five years prior to receipt of application, will be credited with examination elements as follows:

Class of license or privileges	Credits
Commercial extra first,	Elements 1, 2 & 4
Radiotelegraph 1st, 2nd, or 3rd,	Elements 1 & 2
Radiotelephone 1st or 2nd,	Elements 2 & 4
Class A,	Elements 2 & 4

No examination credit is given on account of license of Radiotelephone 3rd Class, nor for other class of license or privileges not above listed.

12.47. *Examination procedure.* Applicants shall write examinations in longhand — code tests and diagrams in ink or pencil, written tests in ink — except that applicants unable to do so because of physical disability may typewrite or dictate their examinations and, if unable to draw required diagrams, may make instead a detailed description essentially equivalent. The examiner shall certify the nature of the applicant's disability and, if the examination is dictated, the name and address of the person(s) taking and transcribing the applicant's dictation.

12.48. *Grading.* Code tests are graded as passed or failed, separately for sending and receiving tests. A code test is failed unless free of omission or other error for a continuous period of at least one minute at required speed. Failure to pass the required code test will terminate the examination. (See Sec. 12.49.)

A passing grade of 75 per cent is required separately for Class B and Class A written examinations.

12.49. *Eligibility for reexamination.* An applicant who fails examination for amateur privileges may not take another examination for such privileges within two months, except that this rule shall not apply to an examination for Class B following one for Class C.

LICENSES

12.61. *Eligibility for amateur station license.* License for an amateur station will be issued only to a licensed amateur operator who has made a satisfactory showing of control of proper transmitting apparatus and control of the premises upon which such apparatus is to be located; provided, however, that in the case of an amateur station of the military or Naval Reserve of the United States located in approved public quarters and established for training purposes, but not operated by the United States Government, a station license may be issued to a person in charge of such a station although not a licensed amateur operator.

12.62. *Eligibility of corporations or organizations to hold license.* An amateur station license will not be issued to a school, company, corporation, association, or other organization; nor for their use; provided, however, that in the case of a bona fide amateur radio society a station license may be issued in accordance with Section 12.61 to a licensed amateur operator as trustee for such society.

12.63. *Location of station.* An amateur radio station, and the control point thereof when remote control is authorized shall not be located on premises controlled by an alien.

12.64. *License period.* License for an amateur station will normally be for a period of three years from the date of issuance of a new, renewed, or modified license.

12.65. *Authorized operation.* An amateur station license authorizes the operation of all transmitting apparatus used by the licensee at the location specified in the station license and in addition the operation of portable and portable-mobile stations at other locations under the same instrument of authorization.

12.66. *Renewal of amateur station license.* An amateur station license may be renewed upon proper application and a showing that, within three months of receipt of the application by the Commission, the licensee thereof has lawfully operated such station in communication by radio with at least three other amateur stations licensed by the Commission, except that in the case of an application for renewal of station license issued for an amateur society or reserve group, the required operation may be by any licensed amateur operator. Upon failure to comply with the above requirements, a successor license will not be granted until two months after expiration of the old license.

12.67. *Posting of station license.* The original of each station license or a facsimile thereof shall be posted by the licensee in a conspicuous place in the room in which the transmitter is located or kept in the personal possession of the operator on duty, except when such license has been filed with application for modification or renewal, or has been mutilated, lost, or destroyed, and application has been made for a duplicate.

CALL SIGNALS

12.81. *Assignment of call letters.* Amateur station calls will be assigned in regular order and special requests will not be considered except that a call may be reassigned to the latest holder, or if not under license during the past five years to any previous holder, or to an amateur organization in memoriam to a deceased member and former holder, and particular calls may be temporarily assigned to stations connected with events of general public interest.

Regulations and Data

12.82. *Call signals for members of U.S.N.R.* In the case of an amateur licensee whose station is licensed to a regularly commissioned or enlisted member of the United States Naval Reserve, the Commandant of the naval district in which such station is located may authorize in his discretion the use of the call-letter prefix N in lieu of the prefix W or K, assigned in the license issued by the Commission; provided that such N prefix shall be used only when operating in the frequency bands 1750-2050 kilocycles, 3500-4000 kilocycles, 56,000-60,000 kilocycles, and 400,000-401,000 kilocycles in accordance with instructions to be issued by the Navy Department.

12.83. *Transmission of call signals.* An operator of an amateur station shall transmit its assigned call at the end of each transmission and at least once every ten minutes during transmission of more than ten minutes' duration; provided, however, that transmission of less than one minute duration from stations employing break-in operation need be identified only once every ten minutes of operation and at the termination of the correspondence. In addition, an operator of an amateur portable or portable-mobile radiotelegraph station shall transmit immediately after the call of the station the fraction-bar character (DN) followed by the number of the amateur call area in which the portable or portable-mobile amateur station is then operating, as for example:

Example 1. Portable or portable-mobile amateur station operating in the third amateur call area calls a fixed amateur station: WIABC WIABC WIABC DE W2DEF DN3 W2DEF DN3 W2DEF DN3 AR.

Example 2. Fixed amateur station answers the portable or portable-mobile amateur station: W2DEF W2DEF W2DEF DE WIABC WIABC WIABC K.

Example 3. Portable or portable-mobile amateur station calls a portable or portable-mobile amateur station: W3GHI W3GHI W3GHI DE W4JKL DN4 W4JKL DN4 W4JKL DN4 AR.

If telephony is used, the call sign of the station shall be followed by an announcement of the amateur call area in which the portable or portable-mobile station is operating.

12.91. *Requirements for portable and portable-mobile operation.* A licensee of an amateur station may operate portable amateur stations (Section 12.3) in accordance with the provisions of Sections 12.82, 12.83, 12.92 and 12.136. Such licensee may operate portable and portable-mobile amateur stations without regard to Section 12.92, but in compliance with Sections 12.82, 12.83 and 12.136, when such operation takes place on authorized amateur frequencies above 28,000 kilocycles.

12.92. *Special provisions for portable stations.* Advance notice in writing shall be given by the licensee to the inspector in charge of the district in which such portable station is to be operated. Such notices shall be given prior to any operation contemplated, and shall state the station call, name of licensee, the date of proposed operation, and the locations as specifically as possible. An amateur station operating under this Section shall not be operated during any period exceeding one month without giving further notice to the inspector in charge of the radio-inspection district in which the station will be operated, nor more than four consecutive periods of one month at the same location. This Section does not apply to the operation of portable or portable-mobile amateur stations on frequencies above 28,000 kilocycles. (See Section 12.91.)

12.93. *Special provisions for non-portable stations.* The provisions for portable stations shall not be applied to any non-portable station except that:

a. An amateur station that has been moved from one permanent location to another permanent location may be operated at the latter location in accordance with the provisions governing portable stations for a period not exceeding sixty days, but in no event beyond the expiration date of the license, provided an application for modification of license to change the permanent location has been made to the Commission.

b. The licensee of an amateur station who is temporarily residing at a location other than the licensed location for a period not exceeding four months may for such period operate his amateur station at his temporary address in accordance with the provisions governing portable stations.

USE OF AMATEUR STATIONS

12.101. *Points of communication.* An amateur station shall communicate only with other amateur stations, except that in emergencies or for testing purposes it may be used also for communication with commercial or Government radio stations. In addition, amateur stations may communicate with any mobile radio station which is licensed by the Commission to communicate with amateur stations, and with stations of expeditions which may also be authorized

to communicate with amateur stations. They may also make transmissions to points equipped only with receiving apparatus for the measurement of emissions, observation of transmission phenomena, radio control of remote objects, and similar purely experimental purposes.

12.102. *No remuneration for use of station.* An amateur station shall not be used to transmit or receive messages for hire, nor for communication for material compensation, direct or indirect, paid or promised.

12.103. *Broadcasting prohibited.* An amateur station shall not be used for broadcasting any form of entertainment, nor for the simultaneous retransmission by automatic means of programs or signals emanating from any class of station other than amateur.

12.104. *Radiotelephone tests.* The transmission of music by an amateur station is forbidden. However, single audio-frequency tones may be transmitted by radiotelephony for test purposes of short duration in connection with the development of experimental radio telephone equipment.

ALLOCATION OF FREQUENCIES

12.111. *Frequencies for exclusive use of amateur stations.* The following bands of frequencies are allocated exclusively for use by amateur stations:

1,750 to 2,050 kc.	28,000 to 30,000 kc.
3,500 to 4,000 kc.	56,000 to 60,000 kc.
7,000 to 7,300 kc.	112,000 to 116,000 kc.
14,000 to 14,400 kc.	224,000 to 230,000 kc.
	400,000 to 401,000 kc.

12.112. *Use of frequencies above 300,000 kilocycles.* The licensee of an amateur station may, subject to change upon further order, operate amateur stations, with any type of emission authorized for amateur stations, on any frequency above 300,000 kilocycles without separate licenses therefor.

12.113. *Individual frequency not specified.* Transmissions by an amateur station may be on any frequency within the bands assigned. Sideband frequencies resulting from keying or modulating a transmitter shall be confined within the frequency band used.

12.114. *Types of emission.*¹ All bands of frequencies allocated to the amateur service may be used without modulation (Type A-1 emission).¹

12.115. *Additional bands for types of emission using amplitude modulation.* The following bands of frequencies are allocated for use by amateur stations using additional types of emission¹ as shown:

1,750 to 2,050 kc.	—	—	A-4	—
1,800 to 2,050 kc.	—	A-3	—	—
28,500 to 30,000 kc.	—	A-3	—	—
56,000 to 60,000 kc.	A-2	A-3	A-4	—
112,000 to 116,000 kc.	A-2	A-3	A-4	A-5
224,000 to 230,000 kc.	A-2	A-3	A-4	A-5
400,000 to 401,000 kc.	A-2	A-3	A-4	A-5

12.116. *Additional bands for radiotelephony.* Amateur stations may use radiotelephony with amplitude modulation (Type A-3 emission)¹ in the frequency bands 3900 to 4000 kc. and 14,150 to 14,250 kc.; provided the station is licensed to a person who holds an amateur operator license endorsed with Class A privileges, and actually is operated by an amateur operator holding Class A privileges.

12.117. *Frequency modulation.* The following bands of frequencies are allocated for use by amateur stations for radiotelephone frequency modulation transmission:²

58,500 to 60,000 kc.
112,000 to 116,000 kc.
224,000 to 230,000 kc.
400,000 to 401,000 kc.

EQUIPMENT AND OPERATION

12.131. *Maximum power input.* The licensee of an amateur station is authorized to use a maximum power input of 1 kilowatt to the plate circuit of the final amplifier stage of an oscillator-amplifier transmitter or to the plate circuit of an oscillator transmitter. An amateur transmitter operating with a power input exceeding nine-hundred watts to the plate circuit shall provide means for accurately measuring

¹ Types of emission: Emissions are classified according to the purpose for which they are used, assuming their modulation or their possible keying to be only in amplitude as follows:

- Type A-1 — Telegraphy on pure continuous waves.
- Type A-2 — Modulated telegraphy.
- Type A-3 — Telephony.
- Type A-4 — Facsimile.
- Type A-5 — Television.

² When using frequency modulation no simultaneous amplitude modulation is permitted.

The Radio Amateur's Handbook

the plate power input to the vacuum tube, or tubes, supply power to the antenna.

12.132. *Power supply to transmitter.* The licensee of an amateur station using frequencies below 60,000 kilocycles shall use adequately filtered direct-current plate power supply for the transmitting equipment to minimize frequency modulation and to prevent the emission of broad signals.

12.133. *Requirements for prevention of interference.* Spurious radiations from an amateur transmitter operating on a frequency below 60,000 kilocycles shall be reduced or eliminated in accordance with good engineering practice and shall not be of sufficient intensity to cause interference on receiving sets of modern design which are tuned outside the frequency band of emission normally required for the type of emission employed. In the case of A-3 emission, the transmitter shall not be modulated in excess of its modulation capability to the extent that interfering spurious radiations occur, and in no case shall the emitted carrier be amplitude-modulated in excess of 100 per cent. Means shall be employed to insure that the transmitter is not modulated in excess of its modulation capability. A spurious radiation is any radiation from a transmitter which is outside the frequency band of emission normal for the type of transmission employed, including any component whose frequency is an integral multiple or submultiple of the carrier frequency (harmonics and subharmonics), spurious modulation products, key clicks, and other transient effects, and parasitic oscillations. The frequency of emission shall be as constant as the state of the art permits.

12.134. *Modulation of carrier wave.* Except for brief tests or adjustments, an amateur radiotelephone station shall not emit a carrier wave on frequencies below 112,000 kilocycles unless modulated for the purpose of communication.

12.135. *Frequency measurement and regular check.* The licensee of an amateur station shall provide for measurement of the transmitter frequency and establish procedure for checking it regularly. The measurement of the transmitter frequency shall be made by means independent of the frequency control of the transmitter and shall be of sufficient accuracy to assure operation within the frequency band used.

12.136. *Logs.* Each licensee of an amateur station shall keep an accurate log of station operation, including the following data:

(a) The date and time of each transmission. (The date need only be entered once for each day's operation. The expression "time of each transmission" means the time of making a call and need not be repeated during the sequence of communication which immediately follows; however, an entry shall be made in the log when "signing off" so as to show the period during which communication was carried on.)

(b) The signature of the person manipulating the transmitting key of a radiotelegraph transmitter or the signature of the person operating a transmitter of any other type (type A-3 or A-4 emission) with statement as to type of emission, and the signature of any other person who transmits by voice over a radiotelephone transmitter (type A-3 emission). (The signature need only be entered once in the log provided the log contains a statement to the effect that all transmissions were made by the person named except where otherwise stated. The signature of any other person who operates the station shall be entered in the proper space for his transmissions.)

(c) Call letters of the station called. (This entry need not be repeated for calls made to the same station during any sequence of communication, provided the time of "signing off" is given.)

(d) The input power to the oscillator, or to the final amplifier stage where an oscillator-amplifier transmitter is employed. (This need be entered only once, provided the input power is not changed.)

(e) The frequency band used. (This information need be entered only once in the log for all transmissions until there is a change in frequency to another amateur band.)

(f) The location of a portable or portable-mobile station at the time of each transmission. (This need be entered only once provided the location of the station is not changed. However, suitable entry shall be made in the log upon changing location, showing the type of vehicle or mobile unit in which the station is operated and the approximate geographical location of the station at the time of operation.)

(g) The message traffic handled. (If record communications are handled in regular message form, a copy of each message sent and received shall be entered in the log or retained on file for at least one year.)

The log shall be preserved for a period of at least one year following the last date of entry. The copies of record communications and station log, as required under this section, shall be available for inspection upon request by an authorized Government representative.

SPECIAL CONDITIONS

12.151. *Additional conditions to be observed by licensee.* An amateur station license is granted subject to the conditions imposed in Sections 12.152 to 12.155 inclusive, in addition to any others that may be imposed during the term of the license. Any licensee receiving due notice requiring the station licensee to observe such conditions shall immediately act in conformity therewith.

12.152. *Quiet hours.* In the event that the operation of an amateur station causes general interference to the reception of broadcast programs with receivers of modern design, such amateur station shall not operate during the hours from 8 o'clock P.M. to 10:30 P.M., local time, and on Sunday for the additional period from 10:30 A.M. until 1 P.M., local time, upon such frequency or frequencies as cause such interference.

12.153. *Second notice of same violation.* In every case where an amateur station licensee is cited a second time within a year for the same violation under Sections 12.111, 12.113, 12.114, 12.116, 12.117, 12.132, or 12.133, the Commission will direct that the station remain silent from 6 P.M. to 10:30 P.M., local time, until written notice has been received authorizing full-time operation. The licensee shall arrange for tests at other hours with at least two amateur stations within fifteen days of the date of notice, such tests to be made for the specific purpose of aiding the licensee in determining whether the emissions of his station are in accordance with the Commission's Regulations. The licensee shall report under oath to the Commission at the conclusion of the tests as to the observations reported by amateur licensees in relation to the reported violation. Such reports shall include a statement as to the corrective measures taken to insure compliance with the Regulations.

12.154. *Third notice of same violation.* In every case where an amateur station licensee is cited the third time within a year for the same violation as indicated in Section 12.153, the Commission will direct that the station remain silent from 8 A.M. to 12 midnight, local time, except for the purpose of transmitting a prearranged test to be observed by a monitoring station of the Commission to be designated in each particular case. Upon completion of the test the station shall again remain silent during these hours until authorized by the Commission to resume full-time operation. The Commission will consider the results of the tests and the licensee's past record in determining the advisability of suspending the operator license and/or revoking the station license.

12.155. *Operation in emergencies.* In the event of widespread emergency conditions affecting domestic communication facilities, the Commission may confer with representatives of the amateur service and others and, if deemed advisable, will declare that a state of general communications emergency exists, designating the licensing area or areas concerned (in general not exceeding 1000 miles from center of the affected area), whereupon it shall be incumbent upon each amateur station in such area or areas to observe the following restrictions for the duration of such emergency:

(a) No transmissions except those relating to relief work or other emergency service such as amateur nets can afford shall be made within the 1750-2050 kilocycle or 3500-4000 kilocycle amateur bands. Incidental calling, testing, or working, including casual conversation or remarks not pertinent or necessary to constructive handling of the general situation shall be prohibited.

(b) The frequencies 2025-2050, 3500-3520, and 3975-4000 kilocycles shall be reserved for emergency calling channels, for initial calls from isolated stations or first calls concerning very important emergency relief matters or arrangements. All stations having occasion to use such channels shall, as quickly as possible, shift to other frequencies for carrying on their communications.

(c) A five-minute listening period for the first five minutes of each hour shall be observed for initial calls of major importance, both in the designated emergency calling channels and throughout the 1750-2050 and 3500-4000 kilocycle bands. Only stations isolated or engaged in handling official traffic of the highest priority may continue with transmissions in these listening periods, which must be accurately observed. No replies to calls or resumption of routine traffic shall be made in the five-minute listening period.

(d) The Commission may designate certain amateur stations to assist in promulgation of its emergency announcement, and for policing the 1750-2050 and 3500-4000 kilocycle bands and warning non-complying stations noted operating therein. The operators of these observing stations shall report fully the identity of any stations failing, after due notice, to comply with any section of this regulation. Such designated stations will act in an advisory capacity

Regulations and Data

when able to provide information on emergency circuits. Their policing authority is limited to the transmission of information from responsible official sources, and full reports of non-compliance which may serve as a basis for investigation and action under Section 502 of the Communications Act. Policing authority extends only 1750-2050 and 3500-4000 kilocycle bands. Individual policing transmissions shall refer to this Section by number, shall specify the date of the Commission's declaration, the area and nature of the emergency, all briefly and concisely. Policing-observer stations shall not enter into discussions beyond essentials with the stations notified, or other stations.

(c) These special conditions imposed under this Section will cease to apply only after the Commission shall have declared such emergency to be terminated.

12.156. *Obscenity, indecency, profanity.* No licensed radio operator or other person shall transmit communications containing obscene, indecent, or profane words, language, or meaning.

12.157. *False signals.* No licensed radio operator shall transmit false or deceptive signals or communications by radio, or any call letter or signal which has not been assigned by proper authority to the radio station he is operating.

12.158. *Unidentified communications.* No licensed radio operator shall transmit unidentified radio communications or signals.

12.159. *Interference.* No licensed radio operator shall willfully or maliciously interfere with or cause interference to any radio communication or signal.

UNITED STATES RADIO DISTRICTS

District	Territory	Address, Radio Inspector-in-Charge
No. 1	The States of Connecticut, Maine, Massachusetts, New Hampshire, Rhode Island and Vermont.	Customhouse, Boston, Mass.
No. 2	The counties of Albany, Bronx, Columbia, Delaware, Dutchess, Greene, Kings, Nassau, New York, Orange, Putnam, Queens, Rensselaer, Richmond, Rockland, Schenectady, Suffolk, Sullivan, Ulster and Westchester of the State of New York; and the counties of Bergen, Essex, Hudson, Hunterdon, Mercer, Middlesex, Monmouth, Morris, Passaic, Somerset, Sussex, Union and Warren of the State of New Jersey.	Federal Building, 641 Washington St., New York, N. Y.
No. 3	The counties of Adams, Berks, Bucks, Carbon, Chester, Cumberland, Dauphin, Delaware, Lancaster, Lebanon, Lehigh, Monroe, Montgomery, Northampton, Perry, Philadelphia, Schuylkill and York of the State of Pennsylvania; and the counties of Atlantic, Burlington, Camden, Cape May, Cumberland, Gloucester, Ocean and Salem of the State of New Jersey; and the county of Newcastle of the State of Delaware.	Room 1200, U. S. Customhouse, Second and Chestnut Sts., Philadelphia, Pa.
No. 4	The State of Maryland; the District of Columbia; and the counties of Arlington, Clark, Fairfax, Fauquier, Frederick, Loudoun, Page, Prince William, Rappahannock, Shenandoah and Warren of the State of Virginia; and the counties of Kent and Sussex of the State of Delaware.	Fort McHenry, Baltimore, Md.
No. 5	The State of Virginia except that part lying in District 4, and the State of North Carolina except that part lying in District 6.	402 New Post Office Bldg., Norfolk, Va.
No. 6	The States of Alabama, Georgia, South Carolina, and Tennessee; and the counties of Ashe, Avery, Buncombe, Burke, Caldwell, Cherokee, Clay, Cleveland, Graham, Haywood, Henderson, Jackson, McDowell, Macon, Madison, Mitchell, Polk, Rutherford, Swain, Transylvania, Watauga and Yancey of the State of North Carolina.	411 Federal Annex, Atlanta, Ga.
No. 7	The State of Florida.	314 Federal Bldg., Miami, Fla.
No. 8	The States of Arkansas, Louisiana and Mississippi; and the city of Texarkana in the State of Texas.	326 Customhouse, New Orleans, La.
No. 9	The counties of Arkansas, Brazoria, Brooks, Calhoun, Cameron, Chambers, Fort Bend, Galveston, Goliad, Harris, Hidalgo, Jackson, Jefferson, Jim Wells, Kenedy, Kleberg, Matagorda, Nueces, Refugio, San Patricio, Victoria, Wharton and Willacy of the State of Texas.	404-406 Federal Bldg., Galveston, Tex.
No. 10	The State of Texas except that part lying in District 9 and in the city of Texarkana; and the States of Oklahoma and New Mexico.	302 U. S. Terminal Annex Bldg., Dallas, Tex.
No. 11	The State of Arizona; the county of Clarke in the State of Nevada; and the counties of Imperial, Inyo, Kern, Los Angeles, Orange, Riverside, San Bernardino, San Diego, San Luis Obispo, Santa Barbara and Ventura of the State of California.	1749 Federal Bldg., Los Angeles, Calif.
No. 12	The State of California except that part lying in District 11; the State of Nevada except the county of Clark.	328 Customhouse, San Francisco, Calif.
No. 13	The State of Oregon; and the State of Idaho except that part lying in District 14.	207 New U. S. Courthouse Bldg., Portland, Ore.
No. 14	The Territory of Alaska; the State of Washington; the counties of Benewah, Bonner, Boundary, Clearwater, Idaho, Kootenai, Latah, Lewis, Nez Perce and Shoshone of the State of Idaho; the counties of Beaverhead, Broadwater, Cascade, Deerlodge, Flathead, Gallatin, Glacier, Granite, Jefferson, Lake, Lewis & Clark, Lincoln, Madison, Meagher, Mineral, Missoula, Pondera, Powell, Ravalli, Sanders, Silver Bow, Teton and Toole of the State of Montana.	808 Federal Office Building, Seattle, Wash.
No. 15	The States of Colorado, Utah and Wyoming; and the State of Montana except that part lying in District 14.	504 Customhouse, Denver, Colo.
No. 16	The States of North Dakota, South Dakota and Minnesota; the counties of Alger, Baraga, Chippewa, Delta, Dickinson, Gogebic, Houghton, Iron, Keweenaw, Luce, Mackinac, Marquette, Menominee, Ontonagon and Schoolcraft of the State of Michigan; and the State of Wisconsin except that part lying in District 18.	208 Uptown P. O. and Federal Courts Bldg., St. Paul, Minn.
No. 17	The States of Nebraska, Kansas and Missouri; and the State of Iowa except that part lying in District 18.	927 U. S. Courthouse, Kansas City, Mo.
No. 18	The States of Indiana and Illinois; the counties of Allamakee, Buchanan, Cedar, Clayton, Clinton, Delaware, Des Moines, Dubuque, Fayette, Henry, Jackson, Johnson, Jones, Lee, Linn, Louisa, Muscatine, Scott, Washington and Winneshiek of the State of Iowa; the counties of Columbia, Crawford, Dane, Dodge, Grant, Green, Iowa, Jefferson, Kenosha, Lafayette, Milwaukee, Ozaukee, Racine, Richland, Rock, Sauk, Walworth, Washington and Waukesha of the State of Wisconsin.	246 U. S. Courthouse Bldg., Chicago, Ill.
No. 19	The State of Michigan except that part lying in District 16; the States of Ohio, Kentucky and West Virginia.	1025 New Federal Bldg., Detroit, Mich.
No. 20	The State of New York except that part lying in District 2, and the State of Pennsylvania except that part lying in District 3.	518 Federal Building, Buffalo, N. Y.
No. 21	The Territory of Hawaii, Guam and American Samoa.	Aloha Tower, Honolulu, T. H.
No. 22	Puerto Rico and Virgin Islands.	303 Ochoa Bldg., San Juan, P. R.

The Radio Amateur's Handbook

12.160. *Damage to apparatus.* No licensed radio operator shall willfully damage, or cause or permit to be damaged, any radio apparatus or installation in any licensed radio station.

12.161. *Fraudulent licenses.* No licensed radio operator or other person shall obtain or attempt to obtain, or assist another to obtain or attempt to obtain, an operator license by fraudulent means.

● TEMPORARY ORDERS AFFECTING AMATEUR REGULATIONS

Because of the international situation, the F.C.C. in June, 1940, forbade amateurs to exchange communications "with operators or radio stations of any foreign government or located in any foreign country," except that it does not apply between continental United States and "United States citizens authorized to operate amateur radio stations in the Philippine Islands or Canal Zone." Communication between F.C.C.-licensed amateurs in the United States and all its possessions and territories is all right, but it should now be remembered that all foreign communication by U. S. amateurs is temporarily forbidden.

Another order, also effective until further

notice, prohibits portable and portable-mobile operation on frequencies below 30 Mc., except during domestic communication emergencies when normal facilities are inadequate or non-existent, and except for the testing and development of self-powered emergency equipment during the daylight hours of Saturday and Sunday of each week, upon 48 hours' advance notice to the F.C.C. inspector in charge of the district. The portable order does not affect the normal operation of Section 12.93 of the regulations, however, although it should be noted that Section 12.93 does not refer to portable *equipment* but merely the use of portable *operating procedure* for the operation of a station's normal fixed equipment under certain conditions.

None of the orders here mentioned are actual changes in the regulations; the regulations remain the same but these orders temporarily affect the operation of some of them. Amateurs should read *QST* each month to keep posted on modification of the above orders, or details of any new ones.

To Handbook Readers Who Are Not A.R.R.L. Members

AMATEUR RADIO OF TO-DAY IS THE
RESULT OF THE EFFORTS OF A.R.R.L.

For Twenty-six Years

the A.R.R.L. has been the organized body of amateur radio, its representative in this country and abroad, its champion against attack by foreign government and American commercial, its leader in technical progress.

To:

Save yourself 50c a year (newsstand copies of *QST* cost \$3).

Be sure of getting your copy of *QST* first.

Be sure of getting your copy of *QST* (newsstands are often sold out).

Be eligible for appointment or election to A.R.R.L. offices.

Be eligible to sign petitions for your Director, your representative on the A.R.R.L. Board.

Be eligible to vote for Director and Section Comm. Manager (only A.R.R.L. members receive ballots).

Lend the strength of your support to the organization which represents YOU at all important radio conferences.

Have YOUR part in the A.R.R.L., which has at heart the welfare of all amateurs.

JOIN THE LEAGUE!

AMERICAN RADIO RELAY LEAGUE
West Hartford, Conn., U. S. A.

I hereby apply for membership in the American Radio Relay League, and enclose \$2.50 (\$3.00 outside of the United States and its Possessions) in payment of one year's dues, \$1.25 of which is for a subscription to *QST* for the same period. Please begin my subscription with the issue. Mail my Certificate of Membership and send *QST* to the following:

Name

Street or Box

City and State

To Handbook Readers Who Are Already A.R.R.L. Members:

FOR members who hold amateur licenses, who are interested in radio activities and Communications Department operating work (explained fully, Chapter 31), here is an application blank which may be filled out for appointment as either Official Relay Station (for telegraphing members) or Official Phone Station (for voice operated member-stations). Copy this, or cut and fill it out, and send it direct to your Section Communications Manager (address in *QST*) or to A.R.R.L. Headquarters, 38 LaSalle Road, West Hartford, Conn., for routing to the proper S.C.M. for attention if you are interested.

The Communications Department field organization includes only the United States and its territories, and Canada, Newfoundland, Labrador, Cuba, and the Philippine Islands. Foreign applications, that is, those from outside these areas, cannot be handled.

APPLICATION FOR APPOINTMENT AS OFFICIAL.....STATION (Relay or Phone?)

To: Section Communications Manager.....Section, A. R. R. L.

Name.....Call.....

Street and Number.....Date.....

City.....State.....County.....

Transmitting frequencies:.....kilocycles

My membership in the A.R.R.L. expires.....
month year



In making application for appointment as Official Relay Station, I agree:

— to obey the radio communication laws and regulations of the country under which this station is licensed, particularly with respect to quiet hours and observance of our frequency allocations.

— to send monthly reports of station activities to the Section Communications Manager under whose jurisdiction this station comes.

— to handle messages in accordance with good operating procedure, delivering messages within forty-eight (48) hours when possible, mailing to destination whenever impossible to relay to the next station in line within a 48-hour period.

— to participate in every A.R.R.L. communication activity to the best of my ability, always trying to live up to those ideals set forth in "The Amateur's Code."

In making application for appointment as Official Phone Station, I agree:

— to obey the radio communication laws of the country under which my station is licensed, particularly with respect to the regulations governing quiet hours and frequencies.

— to send monthly reports of station activities to the Section Communications Manager under whose jurisdiction this station comes; to use such operating procedure as may be adopted by the O.P.S. group; to test outside busy operating hours or using dummy antennas.

— to handle such messages as may come to me, as accurately, promptly and reliably as possible.

— to participate in all amateur communication activities to the best of my ability, always trying to live up to those ideals set forth in "The Amateur's Code" and to carry on amateur operation in a constructive and unselfish spirit.

— to use circuits and adjustments that avoid frequency modulation and over modulation by proper transmitter adjustment (accomplished by use of proper indicating devices) to avoid causing interference unnecessarily.

I understand that this appointment requires annual endorsement, and also may be suspended or cancelled at the discretion of the Section Communications Manager for violation of the agreement set forth above

Please send detailed forms to submit in connection with this application.



Signed.....



The Catalog Section



In the following pages is a catalog-file of products of the principal manufacturers who serve the short-wave field. Appearance in these pages is by invitation—space has been sold only to those dependable firms whose established integrity and whose products have met with the approval of the American Radio Relay League.



INDEX OF MANUFACTURERS

★ CATALOG SECTION ★

The Radio Amateur's Handbook

	Page		Page
Aerovox Corporation	514	Kenyon Transformer Company, Inc.	502
American Phenolic Corporation	480	Mallory & Company, Inc., P. R.	494-495
A.R.R.L.	533-543	McElroy, T. R.	524-525
A.R.R.L. Bookshelf	544	Meissner Mfg. Company	509
Astatic Microphone Laboratory, Inc.	505	Millen Mfg. Company, Inc., James 478-479	
Barker & Williamson	520-521	National Company, Inc.	451-469
Birnbach Radio Company, Inc.	527	Ohmite Mfg. Company	492-493
Bliley Electric Company	482-483	Par-Metal Products Corp.	481
Candler System Company, The	519	Premax Products	496
Cardwell Mfg. Corp., Allen D.	515	RCA Mfg. Company, Inc.	489-491
Centralab	506	Radio Mfg. Engineers, Inc.	512
Clarostat Mfg. Company	523	Raytheon Production Corp.	529
Cornell-Dubilier Electric Corp.	510-511	Solar Mfg. Corp.	530
Corning Glass Works	504	Sprague Products Company	503
Eitel-McCullough, Inc.	508	Struthers Dunn, Inc.	507
Gardiner-Levering Company	484	Teleplex Company	528
General Electric Company	498-499	Triplett Electrical Instrument Company, The	532
Hallicrafters, Inc., The	470-477	Turner Company, The	531
Hammarlund Mfg. Company, Inc.	486-487	United Transformer Corp.	518
Howard Radio Company	516-517	Vibroplex Company, Inc., The	513
Hytronic Laboratories	488		
Instructograph Company, The	497		
International Resistance Company	485		
Johnson Company, E. F.	500-501		

NATIONAL RADIO PRODUCTS

1941

A COMPLETE LINE

	PAGE
Dials and Knobs	2
Condensers	3-8
Couplings	9
Coils and Chokes	9-12
Shields	12
Cabinets	12
Oscilloscopes	13
Plate and Grid Grips	14
Sockets	14, 15
Insulators	14, 15
Amplifiers and Modulators	16
Transmitters	16
Receivers	17-19





FACTS

NATIONAL DIALS

PRECISION 6" DIAL NW

The six-inch NW Dial has an engine divided scale and vernier of solid nickel silver. The vernier is flush with the scale. The variable ratio drive is unusually powerful at all settings. 2, 3, 4 or 5 scale. Standard Dial fits $\frac{3}{8}$ " shaft. $\frac{1}{4}$ " shaft on request.

NW Dial List \$15.00

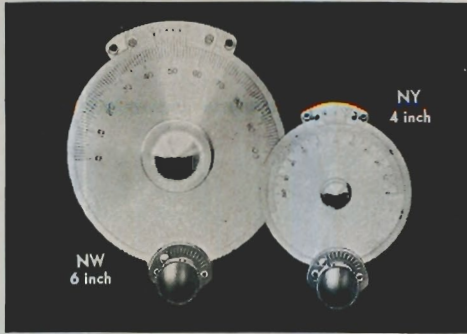

PRECISION 4" DIAL NY

The four-inch NY Dial is similar to the NW Dial except for size. Scales are engine divided on solid nickel silver. A flush vernier and a variable ratio drive are provided. 2, 3, 4 or 5 scale. Fits $\frac{1}{4}$ " shaft.

NY Dial List \$8.00



The four-inch N Dial has an engine divided scale and vernier of solid nickel silver. The vernier is flush with the scale. The planetary drive has a ratio of 5 to 1, and is contained within the body of the dial. 2, 3, 4 or 5 scale. Fits $\frac{1}{4}$ " shaft.

N Dial List \$6.75

The original black bakelite "Velvet Vernier" Dial, Type A, is still an unchallenged favorite for general purpose use. The planetary drive has a ratio of 5 to 1. In 4 inch diameter with 2, 4 or 5 scale, and in $3\frac{3}{8}$ inch diameter with 2 scale. Fits $\frac{1}{4}$ " shaft.

A Dial List \$3.00



"Velvet Vernier" Dial, Type B, has a compact variable ratio 6 to 1 minimum, 20 to 1 maximum drive that is smooth and trouble free. An illuminator is available. The case is black bakelite. 1 or 5 scale. 4" diam. Fits $\frac{1}{4}$ " shaft.

B Dial List \$2.75
Illuminator, extra List \$5.00

The BM Dial is a smaller version of the B Dial (described in the opposite column) for use where space is limited. The drive ratio is fixed. Although small in size, the BM Dial has the same smooth action as the larger units. 1 or 5 scale. 3" diam. Fits $\frac{1}{4}$ " shaft.

BM Dial List \$2.50



INEXPENSIVE DIALS



TYPE R
List \$:75

Etched nickel-silver dial, 1 $\frac{1}{2}$ " Dia. Not insulated from shaft.

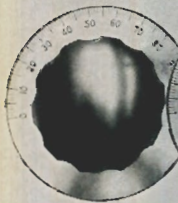

TYPE O
List \$1.50

Etched nickel-silver dial, 3 $\frac{1}{2}$ " Dia. Insulated from shaft.

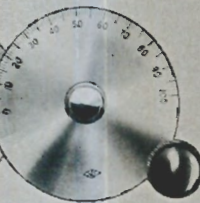

TYPE K
List \$1.50

Etched nickel-silver dial, 3 $\frac{1}{2}$ " Dia. Vernier drive.

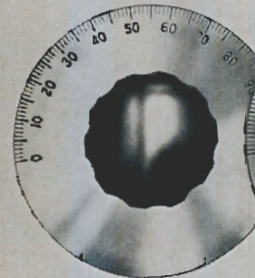

TYPE L
List \$2.50

Etched nickel-silver dial, 5" Dia. Insulated from shaft.

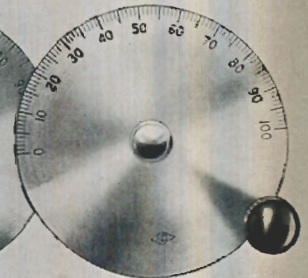

TYPE M
List \$2.50

Etched nickel-silver dial, 5" Dia. Vernier drive.

HRK



HRK (Fits $\frac{1}{4}$ " shaft)
Black bakelite knob 2 $\frac{3}{8}$ " diam.

List \$85

ODL
A locking device which clamps the rim of O, K, L and M Dials. Brass, nickel plated.

List \$50

HRP-P (Fits $\frac{1}{4}$ " shaft)
Black bakelite knob 1 $\frac{1}{4}$ " long and $\frac{1}{2}$ " wide. Equipped with pointer.

List \$35

ODD
Vernier drive for O, K, L, M or other plain dials.

List \$60

HRP List \$15
The Type HRP knob has no pointer, but is otherwise the same as the knob above.

DIAL SCALES

Scale	Divisions	Rotation	Direction of Condenser Rotation for increase of dial reading
1	0-100-0	180°	Either
2	0-100	180°	Counter Clockwise
3	0-100-0	180°	Clockwise
4	150-0	270°	Clockwise
5	200-0	360°	Clockwise
6	0-150	270°	Counter Clockwise

SB (Fits $\frac{1}{4}$ " shaft)

A nickel plated brass bushing $\frac{3}{8}$ " dia.

RSL (Fits $\frac{1}{4}$ " shaft) List \$85

Rotor Shaft Lock for TMA, TMC and similar condensers.



ODL

ODD

RSL

HRP-P

HRP



NATIONAL PRECISION CONDENSERS

The Micrometer dial reads direct to one part in 500. Division lines are approximately 1/4" apart. The dial revolves ten times in covering the tuning range, and the numbers visible through the small windows change every revolution to give consecutive numbering by tens from 0 to 500. The condenser is of extremely rigid construction, with four bearings on the rotor shaft. The drive, at the mid-point of the rotor, is through an enclosed preloaded worm gear with 20 to 1 ratio. Each rotor is individually insulated from the frame, and each has its own individual rotor contact, of the multi-fingered brush type. Stator insulation is Steatite.

PW Ganged Condensers are available in 2, 3 or 4 sections, in either 160 or 225 mmf per section. Larger capacities cannot be supplied.

A single-section PW condenser with grounded rotor is supplied in capacities of 150, 200, 350 and 500 mmf, single spaced, and capacities up to 125 mmf, double spaced. Plate shape is straight-line-frequency when the frequency range is 2:1.

PW condensers and drives are all with rotor shaft parallel to the panel.

NOTE: When ordering specify capacity per section and desired position right or left of dial

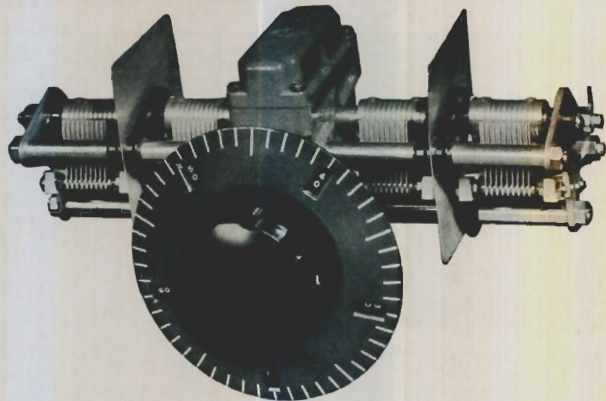

- PW-1, Single Section List \$15.00
- PW-2, Two Section List \$20.00
- PW-3, Three Section List \$24.00
- PW-4, Four Section List \$27.50

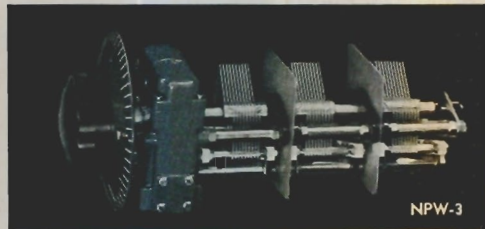
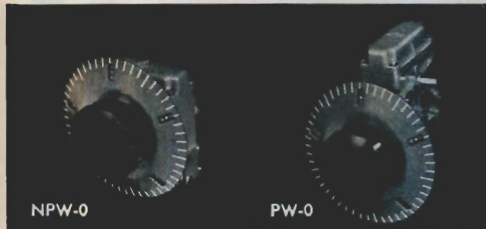

GEAR DRIVE UNITS

With micrometer dial

NPW-O List \$10.50
Uses parts similar to the NPW condenser. Drive shaft perpendicular to panel. One TX-9 coupling supplied.

PW-O List \$13.50
Uses parts similar to the PW condenser. Drive shaft parallel to panel. Two TX-9 couplings supplied.

NPW MODELS

With micrometer dial

NPW-3. Three sections, each 225 mmf. List \$24.50

NPW-X. Three sections, each 25 mmf. List \$20.00

Both condensers are similar to PW models, except that rotor shaft is perpendicular to panel.

NATIONAL RECEIVING CONDENSERS

Capacity	Minimum Capacity	No. of Plates	Air Gap	Catalog Symbol	List
15 Mmf.	1.5	6	.017"	UM- 15	\$1.25
35	2.5	12	.017"	UM- 35	1.50
50	3	16	.017"	UM- 50	1.60
75	3.5	22	.017"	UM- 75	1.70
100	4.5	28	.017"	UM-100	1.90
25	3.4	14	.050"	UMA- 25	1.85
BALANCED STATOR MODEL					
25	2	4-4-4	.017"	UMB- 25	\$1.85

The **UM CONDENSER**, designed for ultra high frequency use is small enough for convenient mounting in our square shield cans. Shaft extensions at each end of the rotor permit easy ganging when used with one of our flexible couplings. The **UMB-25** Condenser is a balanced stator model, two stators act on a single rotor. The **UM** can be mounted by the angle foot supplied or by bolts and spacers.

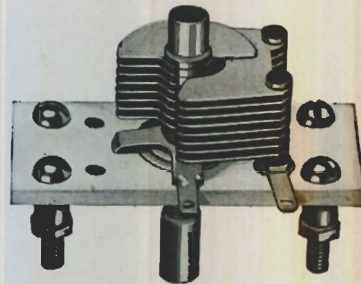

TYPE UM

STRAIGHT-LINE CAPACITY
180° Rotation
Dimensions: Base 1" x 2 1/4"
Mounting Holes: 3/8" x 1 23/32"
Overall Length: 2 1/8"



NATIONAL RECEIVING CONDENSERS

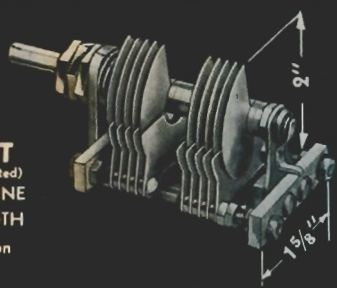

TYPE ST
(Type STD Illustrated)
STRAIGHT-LINE
WAVELENGTH
180° Rotation

Capacity	Minimum Capacity	No. of Plates	Air Gap	Length	Catalog Symbol	List
SINGLE BEARING MODELS						
15 Mmf.	3 Mmf.	3	.018"	1 1/16"	STHS- 15	\$1.40
25	3.25	4	.018"	1 1/16"	STHS- 25	1.50
50	3.5	7	.018"	1 1/16"	STHS- 50	1.60
DOUBLE BEARING MODELS						
35 Mmf.	6 Mmf.	9	.026"	2 1/4"	ST- 50	\$1.50
50	7	11	.026"	2 1/4"	ST- 35	1.80
75	8	15	.026"	2 1/4"	ST- 75	2.00
100	9	20	.026"	2 1/4"	ST-100	2.25
140	10	28	.026"	2 3/4"	ST-140	2.50
150	10.5	29	.026"	2 3/4"	ST-150	2.50
200	12.0	27	.018"	2 1/4"	STH-200	2.75
250	13.5	32	.018"	2 3/4"	STH-250	3.00
300	15.0	39	.018"	2 3/4"	STH-300	3.25
335	17.0	43	.018"	2 3/4"	STH-335	3.50
SPLIT STATOR DOUBLE BEARING MODELS						
50-50	5-5	11-11	.026"	2 3/4"	STD- 50	\$3.50
100-100	5.5-5.5	14-14	.018"	2 3/4"	STHD-100	4.50

NOTE — Type SS Condensers, having straight-line-capacity plates but otherwise similar to the Type ST, are available. Capacities and Prices same as Type ST.

The ST Type condenser has Straight-Line Wavelength plates. All double-bearing models have the front bearing insulated to prevent noise. On special order a shaft extension at each end is available, for ganging. On double-bearing single shaft models, the rotor contact is through a constant impedance pigtail. Isolantite insulation.

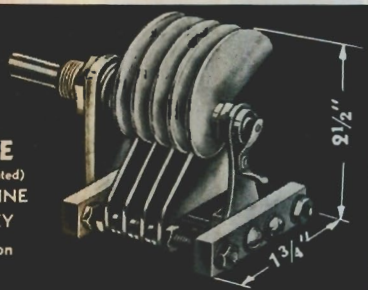

TYPE SE
(Type SEU Illustrated)
STRAIGHT-LINE
FREQUENCY
270° Rotation

Capacity	Minimum Capacity	No. of Plates	Air Gap	Length	Catalog Symbol	List
15 Mmf.	7 Mmf.	6	.055"	2 1/4"	SEU- 15	\$2.50
20	7.5	8	.055"	2 1/4"	SEU- 20	2.75
25	8	9	.055"	2 1/4"	SEU- 25	2.75
50	9	11	.026"	2 1/4"	SE- 50	2.25
75	10	15	.026"	2 1/4"	SE- 75	2.50
100	11.5	20	.026"	2 1/4"	SE-100	2.75
150	13	29	.026"	2 3/4"	SE-150	3.00
200	12	27	.018"	2 1/4"	SEH-200	3.00
250	14	32	.018"	2 3/4"	SEH-250	3.25
300	16	39	.018"	2 3/4"	SEH-300	3.25
335	17	43	.018"	2 3/4"	SEH-335	3.50

TYPE SE — All models have two rotor bearings, the front bearing being insulated to prevent noise. A shaft extension at each end, for ganging, is available on special order. On models with single shaft extension, the rotor contact is through a constant impedance pigtail. The SEU models (illustrated) are suitable for high voltages as their plates are thick polished aluminum with rounded edges. Other SE condensers do not have polished edges on the plates. Isolantite insulation.

EXPERIMENTER
STRAIGHT-LINE
CAPACITY
180° Rotation

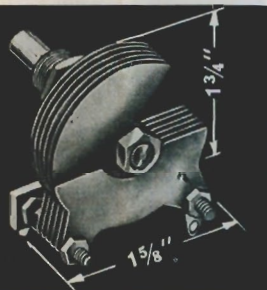

Capacity	Minimum Capacity	Length	Air Gap	No. of Plates	Catalog Symbol	List
15 Mmf.	3.5	1 5/16"	.045"	5	EX- 15	\$.85
25	3.75	1 5/16"	.045"	7	EX- 25	.85
35	3.75	1 5/16"	.045"	10	EX- 35	1.00
50	4	1 5/8"	.017"	6	EX- 50	.90
100	4.75	1 5/8"	.017"	12	EX-100	1.00
140	5.5	1 5/8"	.017"	15	EX-140	1.25

The National "Experimenter" Type Condensers are low-priced models for general experimental work. They are of all-brass construction. The rotor has only one bearing. Plates can be removed without difficulty. Bakelite insulation.





NATIONAL GENERAL PURPOSE CONDENSERS

Capacity	Minimum Capacity	No. of Plates	Length	Catalog Symbol	List
150 Mmf.	9	9	4"	EMC-150	\$3.25
250	11	14	2 ¹⁵ / ₁₆ "	EMC-250	3.75
350	12	20	2 ¹⁵ / ₁₆ "	EMC-350	4.25
500	16	27	4 ³ / ₈ "	EMC-500	4.75
1000	22	55	6 ³ / ₄ "	EMC-1000	7.25
SPLIT-STATOR MODEL					
350-350	12-12	20-20	6"	EMCD-350	\$7.50

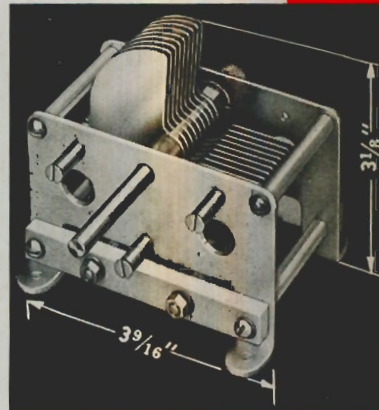

National EMC Condensers are made in large sizes for general purpose uses. They are similar in construction to the TMC Transmitting condenser, and have high efficiency and rugged frames. Insulation is Isolantite, and Peak Voltage Rating is 1000 Volts. Plate shape is Straight-Line Wavelength.

NATIONAL PADDING CONDENSERS

US — See table — Type US condensers are small, compact, low-loss units. Their soldered construction makes them particularly suitable for applications where vibration is present. Adjustment is made with a screw driver. Steatite base.

USE — See table — Type USE condensers are similar to Type US, but are provided with a 1/4" diameter shaft extension at each end.

USL — See table — Type USL condensers are similar to Type US, but are provided with a rotor shaft lock, so that the rotor can be clamped at any setting.

M-30 **List \$3.30**
Type M-30 is a small adjustable mica condenser with a maximum capacity of 30 mmf. Dimensions 1³/₁₆" x 3/16" x 1/2". Isolantite base.

W-75, 75 mmf. List \$2.25
W-100, 100 mmf. List \$2.50
Small padding condensers having very low temperature coefficient mounted in an aluminum shield 1 1/4" in diameter.

Capacity	Catalog Symbol			List
25 mmf.	US-25	USE-25	USL-25	\$1.30
50	US-50	USE-50	USL-50	1.50
75	US-75	USE-75	USL-75	1.70
100	US-100	USE-100	USL-100	1.90
140	US-140	USE-140	USL-140	2.25

NATIONAL NEUTRALIZING CONDENSERS



NC-600U **List \$3.55**
With standoff insulator

NC-600 **List \$4.45**
Without insulator

The NC-600 and NC-600U are for neutralizing low power beam tubes requiring from .5 to 4 mmf, and 1500 max. total volts such as the 6L6. The NC-600U is supplied with a GS-10 standoff insulator screwed on one end, which may be removed for pig-tail mounting.

STN **List \$2.00**

The Type STN neutralizing condenser has a maximum capacity of 18 mmf (3000 V), making it suitable for such tubes as the 10 and 45. It is supplied with two standoff insulators.

TCM **List \$4.00**

The Type TCM neutralizing condenser is similar to the TMC. It has a maximum capacity of 25 mmf (6000 V), making it suitable for the 203A, 211 and similar tubes.

NC-800 **List \$3.00**

The NC-800 disk-type neutralizing condenser is suitable for the RCA-800, 35T, HK-54 and similar tubes. It is equipped with a micrometer thimble and clamp. The chart below gives capacity and air gap for different settings.

NC-75 **List \$4.00**

For 75T, 808, 811, 812 & similar tubes.

NC-150 **List \$6.50**

For HK35-4, RK36, 300T, 852, etc.

NC-500 **List \$12.50**

For WIE-251, 450TH, 450TL, 750TL, etc.

These larger disk-type neutralizing condensers are for the higher powered tubes. Disks are aluminum, insulation steatite.

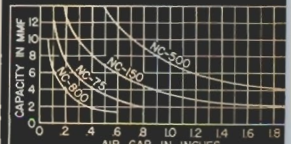
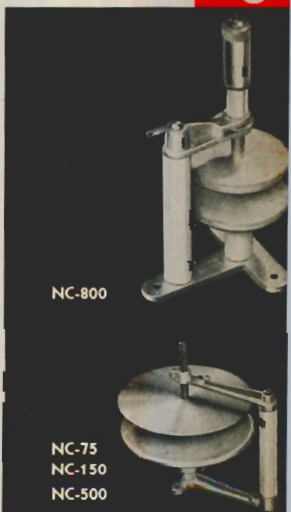



NATIONAL TRANSMITTING CONDENSERS

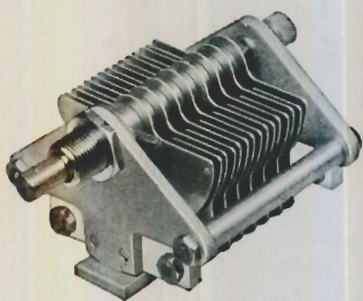

TYPE TMS

is a condenser designed for transmitter use in low power stages. It is compact, rigid, and dependable. Provision has been made for mounting either on the panel, on the chassis, or on two stand-off insulators. Insulation is Isolantite. Voltage ratings listed are conservative.

Capacity	Minimum Capacity	Length	Air Gap	Peak Voltage	No. of Plates	Catalog Symbol	List Price
SINGLE STATOR MODELS							
100 Mmf.	9.5	3"	.026"	1000v.	10	TMS-100	\$2.50
150	11	3"	.026"	1000v.	14	TMS-150	2.75
250	13.5	3"	.026"	1000v.	23	TMS-250	3.00
300	15	3"	.026"	1000v.	27	TMS-300	3.60
35	8	3"	.065"	2000v.	8	TMSA-35	3.00
50	11	3"	.065"	2000v.	11	TMSA-50	3.25
DOUBLE STATOR MODELS							
50-50 Mmf.	6-6	3"	.026"	1000v.	5-5	TMS-50D	\$3.75
100-100	7-7	3"	.026"	1000v.	9-9	TMS-100D	4.50
50-50	10.5-10.5	3"	.065"	2000v.	11-11	TMSA-50D	4.00

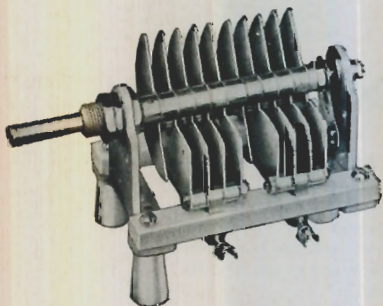

TYPE TMH

features very compact construction, excellent power factor, and aluminum plates .040" thick with polished edges. It mounts on the panel or on removable stand-off insulators. Isolantite insulators have long leakage path. Stand-offs included in listed price.

Capacity	Minimum Capacity	Length	Air Gap	Peak Voltage	No. of Plates	Catalog Symbol	List
SINGLE STATOR MODELS							
50 Mmf.	9	3 ³ / ₄ "	.085"	3500v.	15	TMH-50	\$3.50
75	11	3 ³ / ₄ "	.085"	3500v.	19	TMH-75	4.00
100	12.5	5 ¹ / ₂ "	.085"	3500v.	25	TMH-100	4.75
150	18	6 ¹ / ₂ "	.085"	3500v.	37	TMH-150	6.00
35	11	5 ¹ / ₈ "	.180"	6500v.	17	TMH-35A	5.25
DOUBLE STATOR MODELS							
35-35 Mmf.	6-6	3 ³ / ₄ "	.085"	3500v.	9-9	TMH-35D	\$5.50
50-50	8-8	5 ¹ / ₈ "	.085"	3500v.	13-13	TMH-50D	6.00
75-75	11-11	6 ¹ / ₂ "	.085"	3500v.	19-19	TMH-75D	7.25

NATIONAL TRANSMITTING CONDENSERS

TYPE TMK

is a new condenser for exciters and low power transmitters. Special provision has been made for mounting AR-16 coils in a swivel plug-in mount on either the top or rear of the condenser, (see page 11). For panel or stand-off mounting. Isolantite insulation.

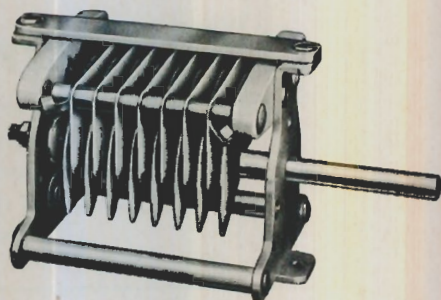

Capacity	Minimum Capacity	Length	Air Gap	Peak Voltage	No. of Plates	Catalog Symbol	List Price
SINGLE STATOR MODELS							
35 Mmf.	7.5	2 ⁷ / ₃₂ "	.047"	1500v.	7	TMK-35	\$3.25
50	8	2 ³ / ₈ "	.047"	1500v.	9	TMK-50	3.50
75	9	2 ¹ / ₁₆ "	.047"	1500v.	13	TMK-75	3.75
100	10	3"	.047"	1500v.	17	TMK-100	4.00
150	10.5	3 ⁵ / ₈ "	.047"	1500v.	25	TMK-150	4.50
200	11	4 ¹ / ₄ "	.047"	1500v.	33	TMK-200	5.00
250	11.5	4 ⁷ / ₈ "	.047"	1500v.	41	TMK-250	5.50
DOUBLE STATOR MODELS							
35-35 Mmf.	7.5-7.5	3"	.047"	1500v.	7-7	TMK-35D	\$5.25
50-50	8-8	3 ⁵ / ₈ "	.047"	1500v.	9-9	TMK-50D	5.75
100-100	10-10	4 ¹ / ₄ "	.047"	1500v.	17-17	TMK-100D	7.25
Extra for Swivel Mounting Hardware for AR 16 Coils							.15

TYPE TMC

is designed for use in the power stages of transmitters where peak voltages do not exceed 3000. The frame is extremely rigid and arranged for mounting on panel, chassis or stand-off insulators. The plates are aluminum with buffed edges. Insulation is Isolantite. The stator in the split stator models is supported at both ends.

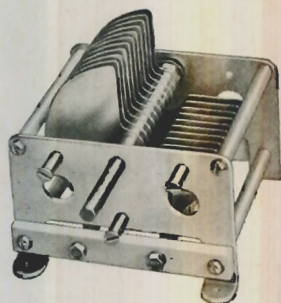

Capacity	Minimum Capacity	Length	Air Gap	Peak Voltage	No. of Plates	Catalog Symbol	List Price
SINGLE STATOR MODELS							
50 Mmf.	10	3"	.077"	3000v.	7	TMC-50	\$4.00
100	13	3 ¹ / ₂ "	.077"	3000v.	13	TMC-100	4.50
150	17	4 ⁵ / ₈ "	.077"	3000v.	21	TMC-150	5.25
250	23	6"	.077"	3000v.	32	TMC-250	6.00
300	25	6 ³ / ₄ "	.077"	3000v.	39	TMC-300	6.50
DOUBLE STATOR MODELS							
50-50 Mmf.	9-9	4 ⁵ / ₈ "	.077"	3000v.	7-7	TMC-50D	\$6.50
100-100	11-11	6 ³ / ₄ "	.077"	3000v.	13-13	TMC-100D	7.50
200-200	18.5-18.5	9 ¹ / ₄ "	.077"	3000v.	25-25	TMC-200D	10.00

NATIONAL RADIO PRODUCTS



NATIONAL TRANSMITTING CONDENSERS

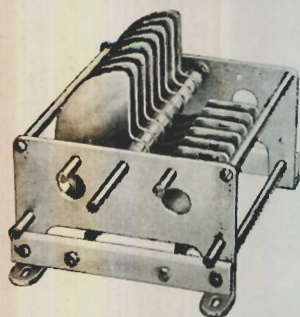

TYPE TMA

is a larger model of the popular TMC. The frame is extremely rigid and arranged for mounting on panel, chassis or stand-off insulators. The plates are of heavy aluminum with rounded and buffed edges. Insulation is Isolantite, located outside of the concentrated field.

Capacity	Minimum Capacity	Length	Air Gap	Peak Voltage	No. of Plates	Catalog Symbol	List Price
SINGLE STATOR MODELS							
300 Mmf.	19.5	4 9/8"	.077"	3000v.	23	TMA-300	\$12.00
50	15	4 3/8"	.171"	6000v.	8	TMA-50A	6.50
100	19.5	6 7/8"	.171"	6000v.	17	TMA-100A	10.00
150	22.5	6 7/8"	.171"	6000v.	23	TMA-150A	12.00
230	33	9 3/8"	.171"	6000v.	35	TMA-230A	16.00
100	30	9 1/4"	.265"	9000v.	23	TMA-100B	13.50
150	40.5	12 1/2"	.265"	9000v.	35	TMA-150B	17.00
50	21	7 1/8"	.359"	12000v.	13	TMA-50C	8.00
100	37.5	12 7/8"	.359"	12000v.	27	TMA-100C	14.50
DOUBLE STATOR MODELS							
200-200 Mmf.	15-15	6 7/8"	.077"	3000v.	16-16	TMA-200D	\$15.00
50-50	12.5-12.5	6 7/8"	.171"	6000v.	9-9	TMA-50DA	11.00
100-100	17-17	9 3/8"	.171"	6000v.	15-15	TMA-100DA	17.50
60-60	19.5-19.5	12 1/2"	.265"	9000v.	15-15	TMA-60DB	18.50
40-40	18-18	12 7/8"	.359"	12000v.	11-11	TMA-40DC	13.50

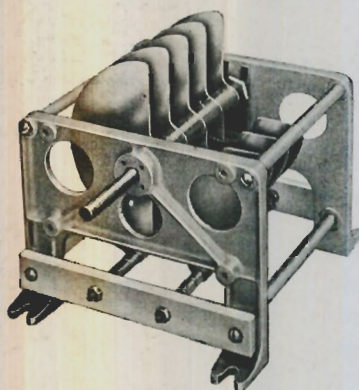

TYPE TML

condenser is a 1 KW job throughout. Isolantite insulators, specially treated against moisture absorption, prevent flashovers. A large self-cleaning rotor contact provides high current capacity. Thick capacitor plates, with accurately rounded and polished edges, provide high voltage ratings. Sturdy cast aluminum end frames and dural tie bars permit an unusually rigid structure. Precision end bearings insure smooth turning and permanent alignment of the rotor. End frames are arranged for panel, chassis or stand-off mountings.

Capacity	Minimum Capacity	Length	Air Gap	Peak Voltage	No. of Plates	Catalog Symbol	List Price
SINGLE STATOR MODELS							
75 Mmf.	25	18 1/2"	.719"	20,000v.	17	TML-75E	\$26.00
150	60	18 1/2"	.469"	15,000v.	27	TML-150D	26.50
100	45	13 3/8"	.469"	15,000v.	19	TML-100D	23.50
50	22	8 3/8"	.469"	15,000v.	9	TML-50D	16.50
245	54	18 1/2"	.344"	10,000v.	35	TML-245B+	28.50
150	45	13 3/8"	.344"	10,000v.	21	TML-150B+	26.00
100	32	10 3/8"	.344"	10,000v.	15	TML-100B+	25.00
75	23.5	8 3/8"	.344"	10,000v.	11	TML-75B+	18.00
500	55	18 1/2"	.219"	7,500v.	49	TML-500A+	35.00
350	45	13 3/8"	.219"	7,500v.	33	TML-350A+	28.00
250	35	10 3/8"	.219"	7,500v.	25	TML-250A+	26.00
DOUBLE STATOR MODELS							
30-30 Mmf.	12-12	18 1/2"	.719"	20,000v.	7-7	TML-30DE	\$26.50
60-60	26-26	18 1/2"	.469"	15,000v.	11-11	TML-60DD	28.50
100-100	27-27	18 1/2"	.344"	10,000v.	15-15	TML-100DB+	31.50
60-60	20-20	13 3/8"	.344"	10,000v.	9-9	TML-60DB+	27.50
200-200	30-30	18 1/2"	.219"	7,500v.	21-21	TML-200DA+	35.00
100-100	17-17	10 3/8"	.219"	7,500v.	11-11	TML-100DA+	28.50



NATIONAL RF CHOKES

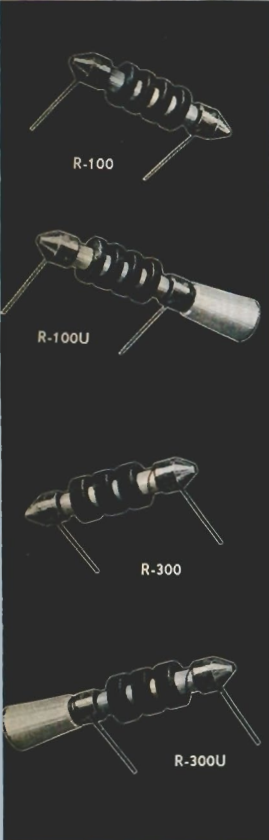

R-100 List \$5.50
Without standoff insulator

R-100U List \$6.60
With standoff insulator

R.F. chokes R-100 and R-100U are identical electrically, but the latter is provided with a removable standoff insulator screwed on one end. Both have Isolantite insulation and both have a continuous universal winding in four sections. Inductance $2\frac{1}{2}$ m.h. distributed capacity 1 mmf. DC resistance 50 ohms, current rating 125 ma.

R-300 List \$5.50
Without insulator

R-300U List \$6.60
With insulator

R.F. chokes R-300 and R-300U are similar in size to R-100U but have higher current capacity. The R-300U is provided with a removable standoff insulator screwed on one end. Inductance 1 m.h.; distributed capacity 1 mmf.; DC resistance 10 ohms; current rating 300 MA.

R-152 List \$2.25

For the 80 and 160 meter bands. Inductance 4 m.h., DC resistance 10 ohms, DC current 600 MA. Coils honeycomb wound on Isolantite core.

R-154 List \$2.25

R-154U List \$1.75

For the 20, 40 and 80 meter bands. Inductance 1 m.h., DC resistance 6 ohms, DC current 600 MA. Coils honeycomb wound on Isolantite core. The R-154U does not have the third mounting foot and the small insulator, but is otherwise the same as R-154. See illustration.

R-175 List \$2.75

The R-175 Choke is suitable for parallel-feed as well as series-feed in transmitters with plate supply up to 3000 volts modulated or 4000 volts unmodulated. Unlike conventional chokes, the reactance of the R-175 is high throughout the 10 and 20 meter bands as well as the 40, 80 and 160 meter bands. Inductance $225 \mu\text{h}$, distributed capacity 0.6 mmf, DC resistance 6 ohms, DC current 800 MA, voltage breakdown to base 12,500 volts.

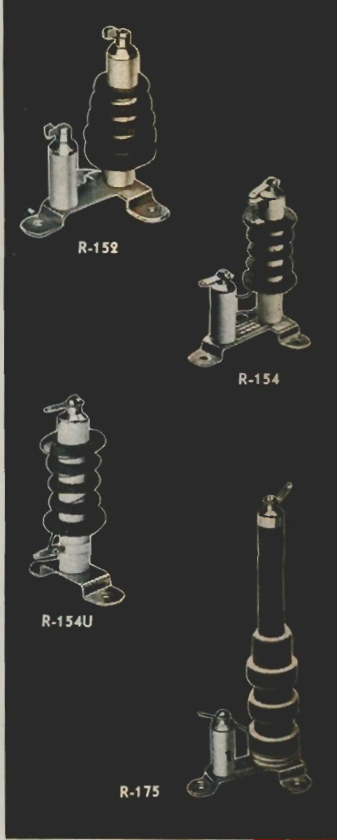

NATIONAL SHAFT COUPLINGS



TX-1, Leakage path 1" List \$1.00

TX-2, Leakage path $2\frac{1}{2}$ " List \$1.10

Flexible couplings with glazed Isolantite insulation which fit $\frac{1}{4}$ " shafts.

TX-8 List \$7.75

A non-flexible rigid coupling with Isolantite insulation. 1" diam. Fits $\frac{1}{4}$ " shaft.

TX-9 List \$1.10

This small insulated flexible coupling provides high electrical efficiency when used to isolate circuits. Insulation is Steatite. $1\frac{5}{8}$ " diam. Fits $\frac{1}{4}$ " shaft.

TX-10 List \$5.55

A very compact insulated coupling free from backlash. Insulation is canvas Bakelite. $1\frac{1}{16}$ " diam. Fits $\frac{1}{4}$ " shaft.

TX-11 List \$6.60

The flexible shaft of this coupling connects shafts at angles up to 90 degrees, and eliminates misalignment problems. Fits $\frac{1}{4}$ " shafts. Length $4\frac{1}{4}$ ".

TX-12, Length $4\frac{5}{8}$ " List \$1.25

TX-13, Length $7\frac{7}{8}$ " List \$1.50

These couplings use flexible shafting like the TX-11 above, but are also provided with Isolantite insulators at each end.

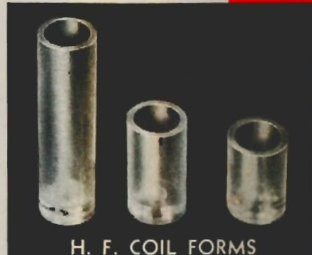

H. F. COIL FORMS

For ultra high frequency work, where very low losses are essential, these small Victron coil forms will be found extremely useful. They can be readily drilled and grooved with ordinary tools, and firmly cemented with National Coil Dope without impairing electrical characteristics.

Symbol	Outside Diameter	Length	List
PRC-1	$\frac{3}{8}$ "	$\frac{3}{8}$ "	\$1.15
PRC-2	$\frac{3}{8}$ "	$\frac{1}{2}$ "	.15
PRC-3	$\frac{3}{8}$ "	$\frac{3}{4}$ "	.15
PRD-1	$\frac{1}{2}$ "	$\frac{1}{2}$ "	.15
PRD-2	$\frac{1}{2}$ "	1"	.15
PRE-1	$\frac{9}{16}$ "	$\frac{3}{4}$ "	.30
PRE-2	$\frac{9}{16}$ "	1"	.30
PRE-3	$\frac{9}{16}$ "	2"	.30
PRF-1	$\frac{3}{4}$ "	$\frac{3}{4}$ "	.30
PRF-2	$\frac{3}{4}$ "	$1\frac{1}{4}$ "	.40

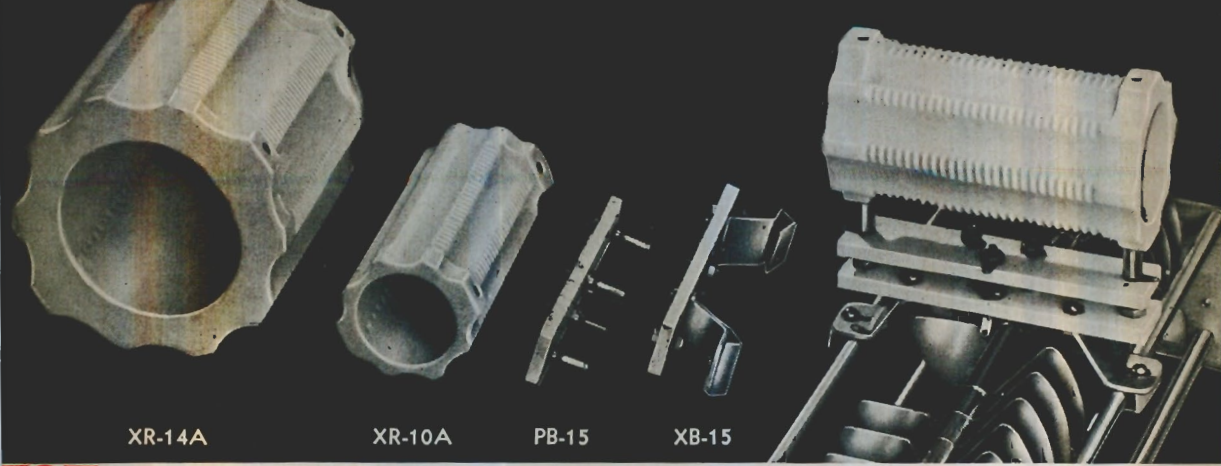

XR-14A

XR-10A

PB-15

XB-15

NATIONAL TRANSMITTER COIL FORMS

The Transmitter Coil Forms and Mounting are designed as a group, and mount conveniently on the bars of a TMA condenser. The larger coil form, Type XR-14A, has a winding diameter of 5" and a winding length of 3³/₄" and is intended for the 80 meter band. The smaller form, Type XR-10A, has a winding length of 3³/₄" and a winding diameter of 2¹/₂". For 20 and 40 meter bands.

Either coil form fits the PB-15 plug. For higher frequencies, the plug may be used with a self-supporting coil of copper tubing. The XB-15 Socket may be mounted on breadboards, chassis, or the TMA Condenser.

SINGLE UNITS

- XR-10A, Coil Form only List \$1.50
- XR-14A, Coil Form only List 3.50
- PB-15, Plug only List 1.35
- XB-15, Socket only List 1.75

ASSEMBLIES

- UR-10A, Assembly (including small Coil Form, Plug and Socket) List \$4.60
- UR-14A, Assembly (including large Coil Form, Plug and Socket) List \$6.25

10 PROD

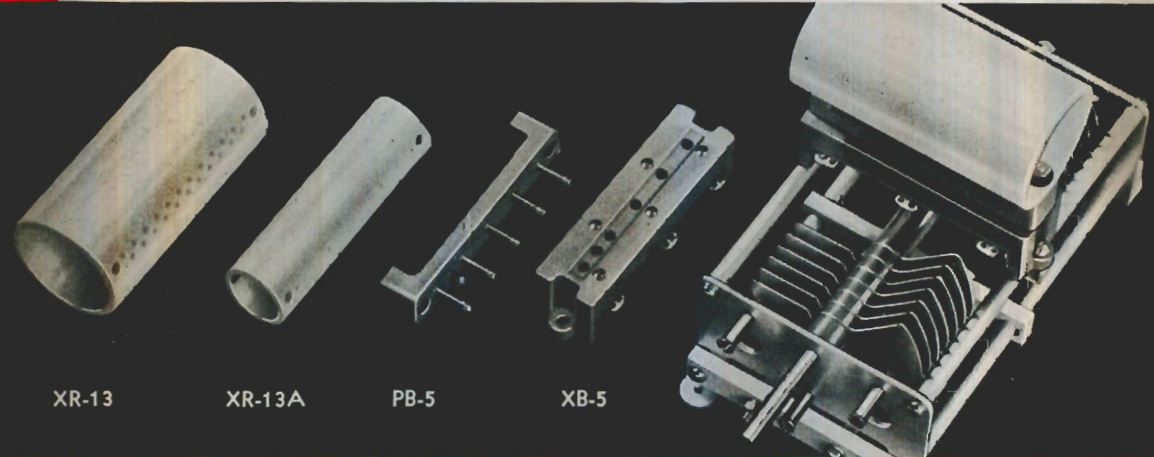

XR-13

XR-13A

PB-5

XB-5

NATIONAL BUFFER COIL FORMS

National Buffer Coil Forms are designed to mount directly on the tie bars of a TMC condenser using the PB-5 Plug and XB-5 Socket. Plug and Socket are of molded R-39.

The two coil forms are of Isolantite, left unglazed to provide a tooth for coil dope. The larger form, Type XR-13, is 1³/₄" in diameter and has a winding length of 2³/₄". The smaller form, Type XR-13A, is 1" in diameter and provides a winding length of 2³/₄". Both forms have holes for mounting and for leads.

SINGLE UNITS

- XR-13, Coil Form only List \$1.10
- XR-13A, Coil Form only List .60
- PB-5, Plug only List .75
- XB-5, Socket only List .75

ASSEMBLIES

- UR-13A, Assembly (including small Coil Form, Plug and Socket) List \$2.00
- UR-13, Assembly (including large Coil Form, Plug and Socket) List \$2.50

NATIO





END LINK



CENTER LINK



SWING LINK

XR-16 FORM



PB-16 PLUG

XB-16 SOCKET

EXCITER COILS AND FORMS—TYPE AR-16 (Air Spaced)

These air-spaced coils are suitable for use in stages where the plate input does not exceed 50 watts and are available in the sizes tabulated below. Capacities listed will resonate the coils at the low frequency end of the band and include all stray circuit capacities. All have separate link coupling coils and all fit the PB-16 Plug and XB-16 Socket.

The XR-16 Coil Form also fits the PB-16 Plug and XB-16 Socket. It has a winding diameter of 1 1/4" and a winding length of 1 3/4".

Order by Catalog Symbol Shown in This Table

Band	End Link	Cap Mmf	Center Link	Cap Mmf	Swinging Link	Cap Mmf
5 meter	AR16-5E	20	AR16-5C	20	—	—
10 meter	AR16-10E	20	AR16-10C	20	AR16-10S	25
20 meter	AR16-20E	26	AR16-20C	26	AR16-20S	40
40 meter	AR16-40E	33	AR16-40C	33	AR16-40S	55
80 meter	AR16-80E	37	AR16-80C	37	AR16-80S	60
160 meter	AR16-160E	65	AR16-160C	65	—	—

XR-16, Coil Form only List \$ 6.60
 PB-16, Plug-in Base only List .40
 XB-16, Plug-in Socket only List .50
 AR-16 Coils — Any type (see table) Each, List \$1.50
 Including PB-16 Plug as illustrated.

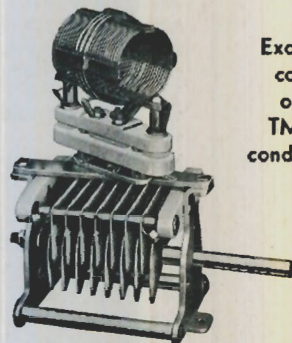

Exciter coil on TMK condenser

NATIONAL RA



IF TRANSFORMER

FIXED-TUNED EXCITER TANK



PLUG-IN BASE AND SHIELD

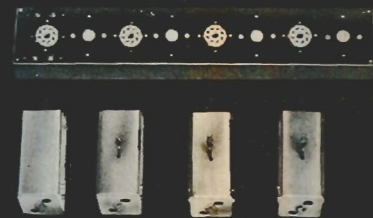

TRF UNITS

I. F. TRANSFORMERS

IFC, Transformer, air core

List \$5.00

IFCO, Oscillator, air core

List \$5.00

Air dielectric condensers isolated from each other by an aluminum shield. Litz wound coils on a moisture proofed ceramic base. Shield can 4 1/8" x 2 3/8" x 2". Available for either 175 KC or 450-550 KC. Specify frequency.

IFD, Diode Transformer, air core

List \$3.50

Tuned primary and untuned, closely-coupled secondary for full-wave diode rectifiers. For noise silencing circuits, etc. 450-550 KC, air core only.

IFE, Transformer, iron core

List \$5.50

FIXED-TUNED EXCITER TANK

FXT, without plug-in base

List \$4.50

FXTB, with base (either 5- or 6-prong)

List \$4.90

Similar in general construction to the I.F. transformer described above, this unit has two 25 mmf, 2000 volt air condensers and an unwound XR-2 coil form.

PLUG-IN BASE AND SHIELD

PB-10, (Base and Shield)

List \$7.75

PB-10A, (Base only)

List \$4.40

The low-loss R-39 base is ideal for mounting condensers and coils when it is desirable to have them shielded and easily removable. Shield can is 2" x 2 3/8" x 4 1/8". Two models are available; 5- or 6-prong.

NATIONAL HIGH FIDELITY TRF UNITS

National Tuners are based on a high performance TRF circuit reduced to its simplest terms. Similar in construction to an IF Amplifier, each chassis provides a three-stage RF Amplifier tuned to one station only. A group of separate chassis are usually used in each installation.

Each RF Transformer is tuned both primary and secondary (8 tuned circuits). The coupling is adjustable to include 10 KC with less than 1 db variation in the audio range. Sensitivity is adjustable from 5 microvolts to one volt. Three models cover ranges of 540-875, 740-1230, and 1100-1700 KC. The chassis fits a standard 3 1/2" relay rack panel.

DLCA, Chassis as illustrated with sockets and terminals riveted in place List \$4.60

DLPS, Steel 1/8" panel List \$1.50

DLPA, Aluminum 3/16" panel List \$5.00

DLT, RF Transformer, set of four required List, each, \$6.50

(Specify approximate operating frequency)

ODUCTS





NATIONAL PARTS

COIL FORMS

XR-1, Four prong, **List \$5.00**

XR-2, without prongs **List \$3.50**

Molded of R-39, permitting them to be grooved and drilled. Coil form diameter 1", length 1 1/2".

XR-3 **List \$3.00**

Molded of R-39. Diameter 3/16", length 3/4". Without prongs.

XR-4, Four prong, **List \$7.50**

XR-5, Five prong, **List \$7.50**

XR-6, Six prong, **List \$7.50**

Molded of R-39, permitting them to be grooved and drilled. Coil form diameter 1 1/2", length 2 1/4". A special socket is required for the six-prong form.

XC6C, Special six prong socket for XR-6 Coil Form, **List \$7.50**

IMPEDANCE COUPLER

S-101 **List \$6.00**

A plate choke, coupling condenser and grid leak sealed in one case, for coupling the output of a regenerative detector to an audio stage. Used in SW-3.

100 KC OSCILL. COIL

OSR **List \$1.50**

A shielded oscillator coil which tunes to 100 KC with .00041 Mfd. Two separate inductances, closely coupled. Excellent for interruption-frequency oscillator in super-regenerative receivers.

SHIELDS

CS-1, 5" x 3" x 3" (outside) **List \$5.00**

CS-2, 5" x 4" x 4" (outside) **List \$6.75**

CS-3, 6 3/4" x 6" x 6" (outside) **List \$13.50**

These rugged cast aluminum shields may be used as cases for small wavemeters, monitors and as stage shields in high-gain equipment.

COIL SHIELDS

RO, coil shield **List \$3.50**

2" x 2 3/8" x 4 1/8" high

J30, coil shield **List \$3.50**

2 1/2" dia. x 3 3/4" high

B30, coil shield **List \$3.50**

3" dia. x 3 3/4" high without mounting base.

B30, coil shield **List \$5.00**

Same as above, but with mounting base.

TUBE SHIELDS

TS, tube shield **List \$4.00**

With cap and base.

T58, tube shield **List \$4.00**

With cap and base, for 77, 78, etc. tubes.

T78, tube shield **List \$4.00**

With cap and base, for 77, 78, etc. tubes.

T14, tube shield **List \$4.00**

2 1/8" high, for 814, RK-20, etc.

T07, tube shield **List \$4.00**

3" high, for 807, RK-23, etc.

JACK SHIELD

JS-1, Jack shield **List \$3.50**

For shield in small standard jacks. For mounting behind a panel, or on the ends of extension cords.



XR-1
XR-2



XR-3

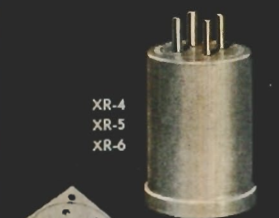

XR-4
XR-5
XR-6



XC-6C



S-101



OSR

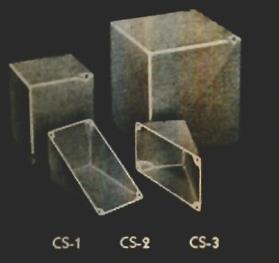

CS-1 CS-2 CS-3

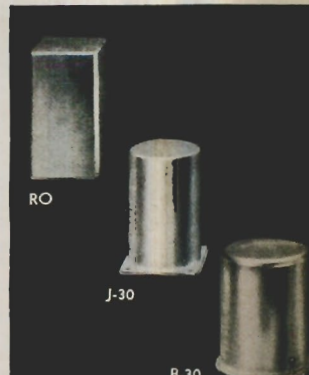

RO

J-30

B-30



TS

T-58

T-78

T-07

T-14



JS-1

NATIONAL CABINETS

The National Cabinets listed below are the same as those used in National Receivers, except that they are supplied in blank form. They are made of heavy gauge steel, and the paint is unusually well bonded to the metal. Sub-bases and bottom covers are included in the price.

Type	Width	Height	Depth	List Price
Type C-HWR	13 1/2"	7"	7 1/4"	\$5.00
Type C-FB7	11 1/2"	8"	12"	7.00
Type C-SW3	9 3/4"	7"	9"	5.50
Type C-NC100	17 1/4"	8 3/4"	11 1/4"	8.50
Type C-HRO	16 3/4"	8 3/4"	10"	8.50
Type C-One-Ten	11"	7"	7 1/4"	4.50
Type C-PSK	6"	8"	12"	6.00
Type C-SRR	7 1/2"	7"	7 1/2"	3.50



CODE PRACTICE OSCILLATOR

CPO, without batteries or tube **List \$6.00**

This small audio oscillator is suitable for either code practice, or as an audio signal source for ICW on the Ultra High Frequency Bands.

A type 30 tube is used, and four flashlight cells in the case provide filament and plate current.

PUSH SWITCH

ACS-4, Four gang, with trigger bar **List \$5.00**

ACS-1, Single section, less trigger bar **List \$1.25**

The National Interlocking Push Switch has low losses, complete reliability and positive contacts. Insulation is R-39. The silverplated contacts are double pole, double throw.

SAFETY METER PANEL

MPF **List \$2.50**

Meter Panel with window

MPS **List \$2.00**

Sub-panel for meters

This new panel makes it safe to connect meters into high-voltage leads. The meters are mounted behind a glass window on a sub-panel. It is available either blank, or punched with 2, 3, or 4 holes for 2" diameter meters. Holes for bolting the meters in place are not provided, as their location varies with different makes of meters. Finish is black wrinkle.

CRYSTAL HOLDERS

4-in 1 **List \$7.50**

Designed to hold four separate crystals up to 1" square, which may be selected by a built-in low capacity switch. Plug-in base. Low loss construction.

CHR **List \$2.50**

A small crystal holder of the resonator type, for use in receivers. Plug-in base. Low loss construction.

CHT **List \$2.50**

A small pressure type crystal holder, for use in transmitters. Plug-in base. Low loss construction.

CHV, less crystal **List \$9.50**

CHV, with crystal **List \$32.50**

A crystal holder of the variable gap type which permits tuning the crystal over a range of one part in 600, when a suitable crystal is used. An 80 meter crystal that will double into the 20 meter phone band is supplied when the holder is ordered with crystal.

CHART FRAMES

Size A, 2 1/4" x 3 1/4" **List \$5.00**

Size B, 3" x 4" **List .60**

Size C, 3 3/4" x 4" **List .70**

National Chart Frames are blanked from one piece of solid nickel silver. Sides of all charts are 1/4" wide. Prices include a celluloid sheet to protect the chart.

SPEAKER CABINETS

NDC-8 for 8" speaker **List \$5.00**

NDC-10 for 10" speaker **List \$6.00**

These cabinets are corrected acoustically to prevent undesired resonance peaks. Acoustic felt lined. Finish: black wrinkle.

COIL DOPE

CD-1, 1/4 pint can **List \$1.50**

Liquid Polystyrene Cement — is ideal for windings as it will not spoil the properties of the best coil form.

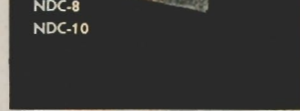

CPO

ACS-4

ACS-1

MPF
MPS

NATIONAL OSCILLOSCOPES

National Oscilloscopes have power supply and input controls built in. A panel switch permits use of the built-in 60-cycle sweep or external audio sweep for securing the familiar trapezoid pattern for modulation measurements.

CRM, less tubes **List \$18.50**

1" screen, using RCA-913 and 6X5 rectifier. Table model, 4 1/8" x 6 1/8" x 8".

CRR, less tubes **List \$32.50**

2" screen, using RCA-902 and 6X5 rectifier. Relay rack mounting.

NATIONAL OSCILLOSCOPES

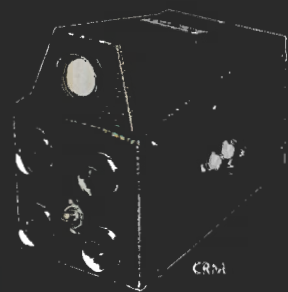

CRM



CRR



NATIONAL LOW-LOSS SOCKETS AND INSULATORS



XCA List \$1.50
A low-loss socket for acorn triodes.

XMA List \$2.00
For pentode acorn tubes, this socket has built-in by-pass condensers. The base is a copper plate.

XM-10 List \$1.25
A heavy duty metal shell socket for tubes having the UX base.

XM-50 List \$1.75
A heavy duty metal shell socket for tubes having the Jumbo 4-pin base ("fifty watt-ers").

JX-50 List \$1.20
Without Standoff Insulators

JX-50S List \$1.50
With Standoff Insulators

A low-loss wafer socket for the 813 and other tubes having the Giant 7-pin Base.

JX-100 List \$3.00
Without Standoff Insulators

JX-100S List \$3.60
With Standoff Insulators

A low-loss wafer socket for the 803, RK-28 and other tubes using the Giant 5-pin Base.

SAFETY GRID & PLATE CAPS

SPG List \$3.35
9/16" Cap, R-39 L. L. insulation

SPP-9 List \$3.35
9/16" Cap L. L. ceramic insulation. These offer protection against accidental contact with High Voltage lobe Caps

SPP-3 List \$3.30
3/8" Cap L. L. ceramic insulation

GRID & PLATE GRIPS

12, for 9/16" Caps List \$1.10

24, for 3/8" Caps List .05

8, for 1/4" Cap List .05

12 & 24 suitable for glass tubes
8 is for metal tubes

GS-1, 1/2" x 13/8" List \$.25

GS-2, 1/2" x 27/8" List .35

GS-3, 3/4" x 27/8" List .90

GS-4, 3/4" x 47/8" List 1.10

GS-4A, 3/4" x 6" List 1.60

Cylindrical low-loss steatite stand-off insulators with nickel plated caps and bases.

GSJ, (not illustrated) List \$1.10
A special nickel plated jack top threaded to fit the 3/4" diam. Insulators GS-3, GS-4 & GS-4A.

GS-5, 1 1/4" List, each \$2.25

GS-6, 2" List, each .45

GS-7, 3" List, each .75

GS-10, 3/4", package of 10 List \$7.75

These cone type standoff insulators are of low-loss steatite. They have a tapped hole at each end for mounting.

GS-8, Plain List \$3.35

GS-9, with Jack List .50

These low-loss steatite stand-off insulators are also useful as lead-through bushings.

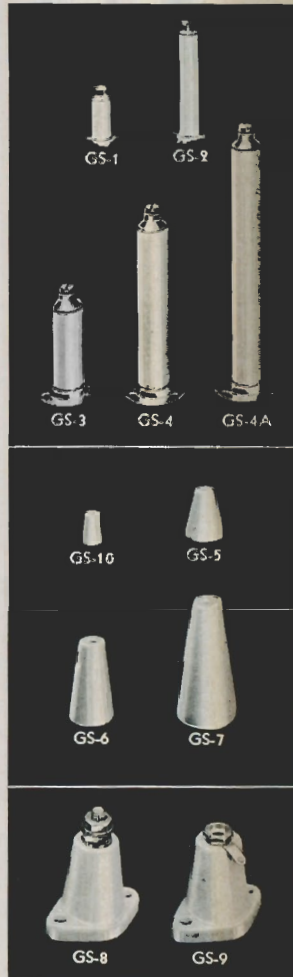

XC Series Sockets

Any Type List \$6.00

National wafer sockets have exceptionally good contacts with high current capacity together with low loss insulating insulation. All types have a locating groove to make tube insertion easy, with the exception of the Octal socket which has a central locating hole.

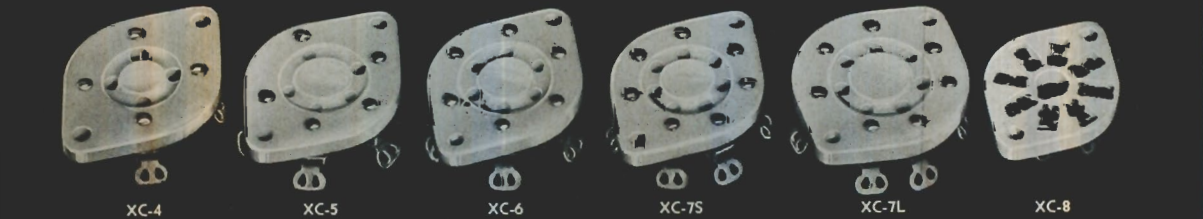

NATIONAL LOW-LOSS SOCKETS AND INSULATORS

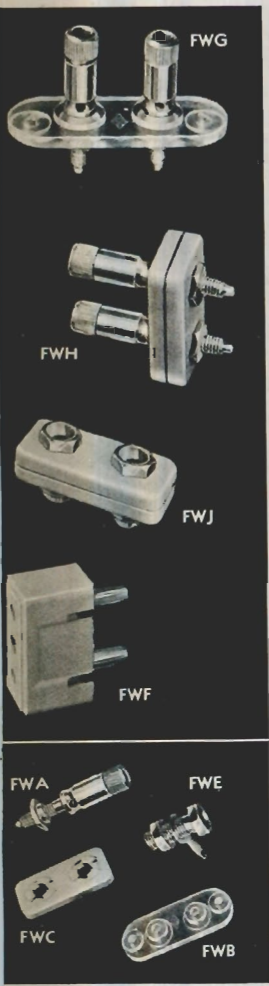

FWG List \$.60

A Victron terminal strip for high frequency use. The binding posts take banana plugs at the top, and grip wires through hole at the bottom, simultaneously, if desired.

FWH List \$.85

The insulators of this terminal assembly are molded R-39 and have serrated bosses that allow the thinnest panel to be gripped firmly, and yet have ample shoulders. Binding posts same as FWG above.

FWJ List \$.65

This assembly uses the same insulators as the FWH above, but has jacks. When used with the FWF plug (below), there is no exposed metal when the plug is in place.

FWF List \$ 1.00

This molded R-39 plug has two banana plugs on $\frac{3}{4}$ " centers and fits FWH or FWJ above. Leads may be brought out through the top or side.

FWA, Post List, each \$.25
Brass Nickel Plated

FWE, Jack List, each \$.15
Brass Nickel Plated

FWC, Insulator List, per pair \$.35
R-39 Insulation

FWB, Insulator List, each \$ 1.10
Polystyrene insulation

AA-3 List \$.30

A low-loss steatite spreader for 6 inch line spacing. (600 ohms impedance with No. 12 wire.)

AA-5 List \$.30

A low-loss steatite aircraft-type strain insulator.

AA-6 List \$.35

A general purpose strain insulator of low-loss steatite.

XS-6 List, each \$ 1.15

A low-loss isolantite bushing for $\frac{1}{2}$ " holes.

TPB List, per dozen \$.75

A threaded Polystyrene bushing with removable .093 conductor moulded in, $\frac{3}{8}$ " diam., 32 thread.

XS-7, ($\frac{3}{8}$ " Hole) List \$.50

XS-8, ($\frac{1}{2}$ " Hole) List \$.65

Steatite bushings. Prices include male and female bushings with metal fittings.

XS-1, (1" Hole) List \$.75

XS-2, (1 $\frac{1}{2}$ " Hole) List \$.90

Prices listed are per pair, including metal fittings. Insulation — steatite.

XS-3, (2 $\frac{3}{4}$ " Hole) List \$ 5.00

XS-4, (3 $\frac{3}{4}$ " Hole) List \$ 6.50

Prices are per pair, including metal fittings. These low-loss steatite bowls are ideal for lead-in purposes at high voltages.

XS-5, Without Fittings List, each, \$ 7.50

XS-5, With Fittings List, per pair, \$ 15.50

These big low-loss bowls have an extremely long leakage path and a $5\frac{1}{4}$ " flange for bolting in place. Insulation — steatite.

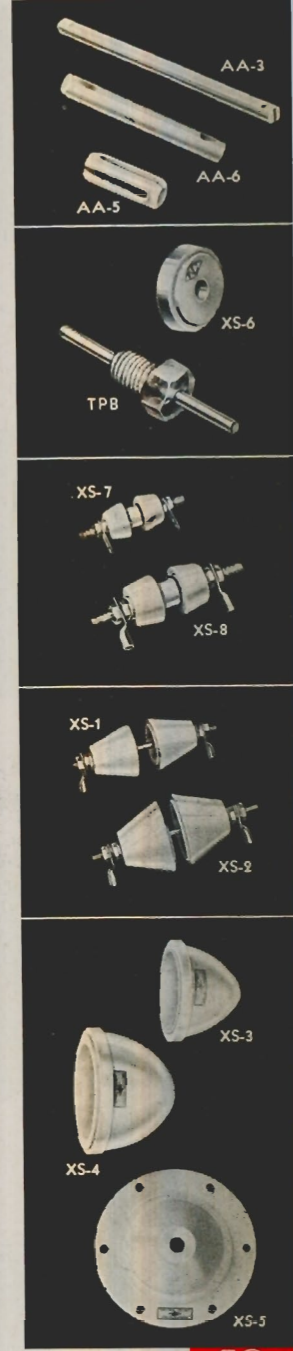

CIR Series Sockets

Any Type List \$.40

Type CIR Sockets feature low-loss isolantite or steatite insulation, a contact that grips the tube prong for its entire length, and a metal ring for six position mounting. The sockets are supplied with two metal standoffs.

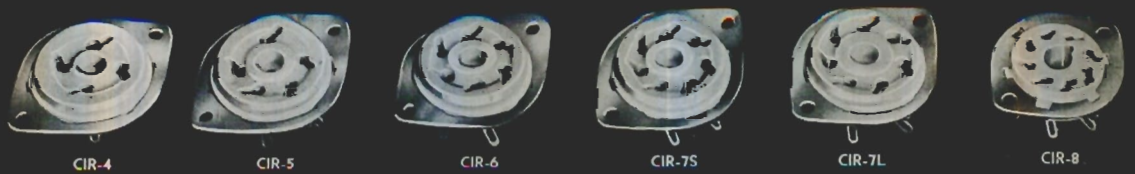



NTE EXCITER-AMPLIFIER

The ideal answer to transmitter control at the operating position, the NTE combines a multiband exciter with a high gain speech amplifier. In the exciter, a crystal oscillator is followed by three frequency multiplier stages, giving a choice of four amateur bands, selected by a push button switch on the panel. Crystals plug in from the front panel, and special holders provide for a choice of frequencies in each band. The speech amplifier delivers 10 watts with an input of .005 volts. A complete description and price listing will be found in our 1941 catalogue No. 400. **NTE Exciter-Amplifier, List \$215.00, Table Model.**



NSA SPEECH AMPLIFIER

Two input circuits with an electronic mixer, one with 125 db gain for crystal microphones, etc., and the other with one less stage for phonograph pickups, etc. 15 watts output from fixed-bias PP 2A3's. Frequency characteristic within 1 db from 25 to 10,000 cycles. A complete description and listing will be found in our 1941 catalogue No. 400. **NSA Amplifier, List \$115.00, Table Model.**

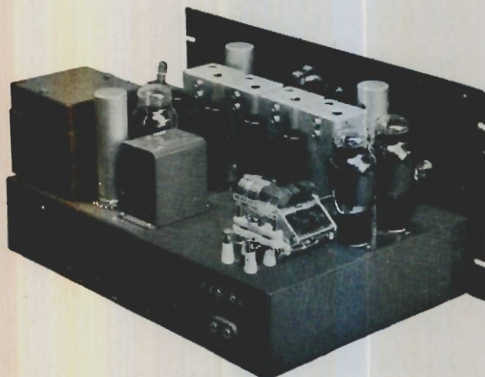

NTX-30 TRANSMITTER

Similar to the NTE Exciter described above, but with an output stage substituted for the speech amplifier. The NTX-30 is a self-contained CW Transmitter with an output of 30 watts on 10, 20, 40 and 80 meters. For phone an external modulator, such as the NSM described below, must be used. The NTX-30 makes an ideal exciter-buffer for a high power station. A complete description and listing will be found in our 1941 catalogue No. 400. **NTX-30 Transmitter, List \$195.00, Table Model.**



NSM MODULATOR

The NSM Modulator features 30 watts output, 50 to 10,000 cycle range, Automatic Volume Compression, DB meter showing amount of compression, Tone Control, and two separate input circuits. A complete description and price listing will be found in our 1941 catalogue No. 400. **NSM Modulator, List \$130.00, Table Model.**

NATIONAL NC-200

The National NC-200 is a new communications receiver having a number of features not previously available. Twelve tubes are used in a highly perfected circuit that includes an extremely effective noise limiter. The crystal filter has an exceptionally wide selectivity range for use on both CW and phone, as well as a phasing circuit that makes rejection ratios as high as 10,000 to 1 available even when the interfering signal is only a few hundred cycles from the desired signal. The AVC holds the audio constant within 2 db for signals from 10 microvolts to 100,000 microvolts. The sensitivity of the NC-200 is particularly high, requiring only 1 microvolt input for 1 watt of audio output on the highest frequencies covered by the receiver. Signal-to-image ratio is better than 30 db at ten meters.

There are ten calibrated coil ranges, each with its own scale on the direct-reading dial. Six of these ranges provide continuous coverage from 490 KC to 30 MC. The remaining four ranges cover the 10, 20, 40 and 80 meter bands, each of which is spread over the major portion of the dial scale. Ranges are selected by a panel control knob. A movable-coil system similar to the NC-100 is used. The inertia-type dial drive has a ratio of 30 to 1.

All models of the NC-200 are suitable for either AC or battery operation, having both a built-in AC power supply and a special detachable cable and plug for battery connection. Removal of the speaker plug disconnects both plate and screen

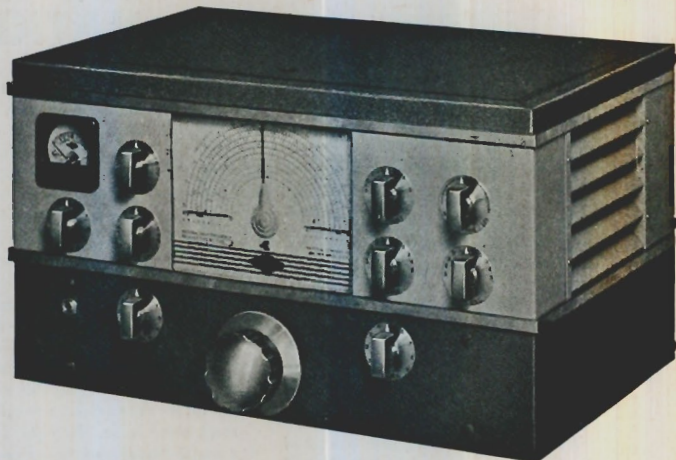

circuits of the audio power stage thus providing maximum battery economy. The B supply filter and the standby switch are wired to the battery terminals, so that the filter is available for vibrator or dynamotor B supplies.

The ten-inch speaker is housed in a separate cabinet specially designed to harmonize with the trim lines of the receiver. The undistorted output is 8 watts.

All features expected in a fine communication receiver are provided. These include CW oscillator, Signal Strength Meter, B-supply switch, etc.

NC-200 TG Table Model, two tone Gray wrinkle. List \$245.83

Price includes a 10" P.M. dynamic speaker in cabinet.

NC-200 RG Rack Model, Gray or Black wrinkle, mounted on 3/16" aluminum panel. List \$275.83

Price includes a 10" P.M. dynamic speaker mounted on 10 1/2" rack panel.

NATIONAL NC-44

The NC-44 Communication Receiver employs seven tubes in a superheterodyne circuit. There are separate controls for RF and AF gain, and on and off switches for the AVC and CWO circuits.

A straight-line-frequency condenser is used in conjunction with a separate band spread condenser. The full vision dial is calibrated in frequency for each range covered. A coil switch selects the four ranges from 550 KC to 30 MC.

NC-44 — Receiver, complete with tubes, coils covering from 550 KC to 30 MC, and

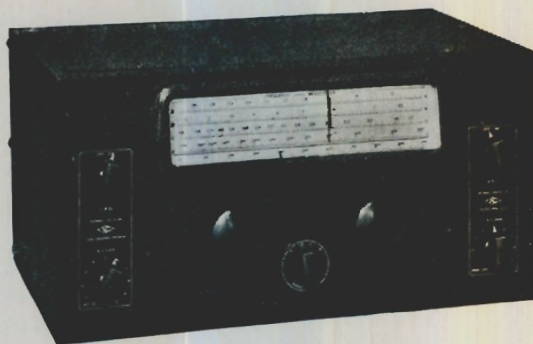

speaker in cabinet, for 105-130 volts AC or DC operation — black finish.

List \$82.50

NC-44B — Receiver, same as above but for battery operation, less batteries.

List \$82.50

NC-44A — Receiver, same as above but for 105-130 volts AC only.

List \$82.50



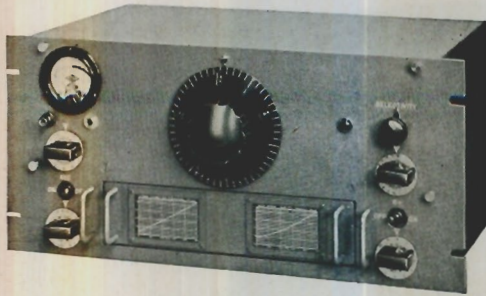

All models of the HRO are supplied with 6.3 volt heater type tubes. Table models and accessories are finished in black wrinkle enamel.

HRO table model, receiver only, complete with four sets of coils (1.7-4.0, 3.5-7.3, 7.0-14.0, 14.0-30.0 MCS). List \$299.50

HRO Jr., table model, receiver only, with one set of 14 to 30 mc. coils. List \$180.00

COILS

HRO Type E, Range 900-2050 kc List \$20.00

HRO Type F, Range 480-960 kc List \$20.00

HRO Type G, Range 180-430 kc List \$27.50

HRO Type H, Range 100-200 kc List \$30.00

HRO Type I, Range 50-100 kc List \$37.50

HRO Jr. Type JA, Range 14.0-30.0 mc List \$16.50

HRO Jr. Type JB, Range 7.0-14.4 mc List \$16.50

HRO Jr. Type JC, Range 3.5-7.3 mc List \$16.50

HRO Jr. Type JD, Range 1.7-4.0 mc List \$16.50

MCS table model cabinet, 8" PM dynamic speaker and matching transformer List \$16.50

697 Table power unit, 115 volt, 60 cycle input; 6.3 volt heater and 230 volt, 75 m.a. output, with tube List \$26.50

See our 1941 catalogue No. 400 for relay rack Mounting, coil containers and accessories.



NC-100A — complete with tubes. AC model — 10" speaker in cabinet. List \$200.00

NC-100XA — complete with tubes and crystal filter. AC model — 10" speaker. List \$237.50

NC-101X — complete with tubes. AC model — 10" speaker in cabinet. List \$215.00

NC-101XA — complete with tubes. AC model — 10" speaker in cabinet. List \$215.00

See our 1941 catalogue No. 400 for battery models, 12 inch speakers, 200-400 kc range, etc.

NATIONAL HRO

The HRO Receiver is a high-gain superheterodyne designed for communication service. Two preselector stages give remarkable image suppression, weak signal response and high signal-to-noise ratio. Air-dielectric tuning capacitors account, in part, for the high degree of operating stability. A crystal filter with both variable selectivity and phasing controls makes possible adjustment of selectivity over a wide range. Heterodynes and interfering c.w. signals may be "phased out" (attenuated) by correct setting of the phasing control. A signal strength meter, connected in a vacuum tube bridge circuit, is calibrated in S units from 1 to 9 and in db above S9 from 0 to 40. Also included are automatic and

manual volume control features, a beat oscillator, a headphone jack and a B+ stand-by switch. Power supply is a separate unit. The standard model of HRO is supplied with four sets of coils covering the frequencies from 1.7 to 30 megacycles. Each coil set covers two amateur bands and the spectrum between. The higher frequency amateur band of each range, by a simple change-over operation, may be expanded to occupy 400 divisions of the 500 division PW instrument type dial.

For those who require the high performance of the HRO but do not need its extreme versatility, the HRO Jr. is offered. The fundamental circuit and mechanical details of both receivers are identical, but the HRO Jr. is simplified by omitting the crystal filter, signal strength meter and by supplying coils less the band-spread feature.

The frequency range of both the HRO and HRO Jr. may be extended to 50 kilocycles by using additional coil sets.

A technical bulletin covering completely all details will be supplied upon request.

NATIONAL NC-100A NC-101X

These 11 tube superheterodyne receivers are self-contained (except for the speaker) in a table model cabinet that is readily adapted to relay rack mounting. One stage of R.F. and two stages of I.F. are used. Low loss insulation and high-Q coils give ample sensitivity and selectivity. Separate R.F. and Audio Gain Controls and a signal strength meter are mounted on the panel. Other controls are tone, CW Oscillator, AVC with amplified and delayed action, a B+ switch, and a phone jack. A self-contained power supply provides all necessary voltages including speaker field excitation. The range changing system is unique in that it combines the mechanical convenience of a coil switch with the electrical efficiency of plug-in coils.

All NC-100 series receivers are fitted with a noise limiter of truly remarkable effectiveness.

The NC-100A, illustrated above, covers the range from 540 KC to 30 MC. The large full vision dial is calibrated directly in megacycles and a separate high speed vernier scale provides high precision in logging.

The NC-100XA is similar but equipped with a crystal filter.

The NC-101X, illustrated below, is built strictly for the amateur bands and covers only the following ranges: 1.7-2.05 MC, 3.5-4.0 MC, 7.0-7.3 MC, 14.0-14.4 MC, and 28.0-30.0 MC. The NC-101X is equipped with a crystal filter, S-meter, and the PW type instrument dial.

The NC-101XA has the same features as the NC-101X, except for the direct reading dial and the cabinet, which are similar to the NC-100XA.



NATIONAL NHU

This specialized communication receiver is a super-heterodyne covering the range from 27 to 62 MC in three ranges, each being calibrated on a direct reading full-vision dial. The circuit uses three acorn tubes, and includes a Noise Limiter, Carrier-off Noise Suppressor, and Amplified and Delayed AVC.

One large knob on the panel slides in or out to engage either the tuning condenser or the range-changing system. Inertia-type tuning is used, with a ratio of approximately 70 to 1. The pointer is positively driven by rack and pinion, and moves vertically when the coil range is changed so that it always points to the proper frequency. The coils are mounted radially in a cast aluminum turret which is easily turned into position by the knob on the panel. Directly above the coil turret is the three-gang straight-line-frequency tuning condenser. The RF circuit and tubes are built completely inside the frame of the condenser, thus making a compact assembly with the shortest possible leads from coils to condensers to tubes.

All features and controls commonly found in high-quality communication receivers are incorporated in the NHU, including a wide range crystal filter.



NHU Receiver, table model, complete with tubes, 8" speaker with cabinet and coils covering from 27 to 62 MC, but without power supply, black finish. **List \$275.00**

NHU-20 Receiver, same as NHU but with 20 Meter Coil. **List \$290.00**

5856 Power Supply, table model with rectifier, for NHU or NHU-20.

See our 1941 catalogue No. 400 for battery operation, relay rack mounting, etc.

NATIONAL ONE-TEN

The One-Ten Receiver fulfills the need for an adequate receiver to cover the field between one and ten meters.

A four-tube circuit is used, composed of one tuned R.F. stage, a self-quenching super-regenerative detector, transformer coupled to a first stage of audio which is resistance coupled to the power output stage. Tubes required: 954-R.F.; 955-Detector; 6C5-1st Audio, 6F6-2nd Audio.



110 Receiver and 6 sets of coils, without tubes, speaker or power supply. **List \$85.00**

5886 Power Supply for above receiver, with tube. **List \$29.50**

NATIONAL SW-3

SW-3, universal model, without coils, phones, tubes or power supply. **List \$35.00**

5886-AB, Power Supply, 115 V, 60 cycle, with 80 Rectifier. **List \$29.50**

General Coverage Coils

Cat. No.	Range — Meters	List Per Pair
30	9 to 15	5.00
31	13.5 to 25	5.00
32	23 to 41	5.00
33	40 to 70	5.00
34	65 to 115	5.00
35	115 to 200	5.00
36	200 to 360	5.50
37	350 to 550	5.50
38	500 to 850	6.50
39	850 to 1200	8.00
40	1200 to 1500	8.00
41	1500 to 2000	8.00
42	2000 to 3000	10.00

Band Spread Coils

30A	— 10 meter	5.00
31A	— 20 meter	5.00
33A	— 40 meter	5.00
34A	— 80 meter	5.00
35A	— 160 meter	5.00

The SW-3 Receivers employ a circuit consisting of one R.F. stage transformer coupled to a regenerative detector and one stage of impedance coupled audio. This circuit provides maximum sensitivity and flexibility with the smallest number of tubes and the least auxiliary equipment. The single tuning dial operates a precisely adjusted two gang condenser; the regeneration control is smooth and noiseless, with no backlash or fringe howl; the volume control is calibrated from one to nine in steps corresponding to the R scale.

ONE UNIVERSAL MODEL — The circuit of the SW-3 is arranged for either battery or AC operation without coil substitution or circuit change. Battery operation utilizes two 1N5-G and one 1A5-G tubes. AC operation utilizes type 5886 AB power supply with two 6J7-G and one 6C5-G tubes.

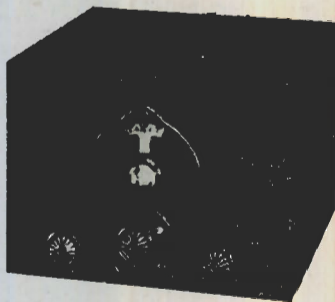

WORLD'S LARGEST BUILDERS OF AMATEUR COMMUNICATIONS EQUIPMENT

The New SUPER SKYRIDER 28



The new 1941 Super Sky rider sets a new high in standards for communications receiver performance. 15 tubes. Frequency range 550 kc to 43 mc in 6 bands. Each control performs a definite function that contributes to the outstanding reception capabilities of the unit, all the controls are conveniently placed for ease of operation. All components arranged for best electrical efficiency with full consideration for convenience of control mountings. The coil assembly has been rigidly constructed and extreme care has been taken to completely shield each section from the other.

The new Super Sky rider has an image ratio of 45 to 1 at 28 mc — 350 to 1 at 14 mc and a proportionately increasing ratio as the frequency is lowered. While the two RF stages are principally needed to obtain such image ratios they also perform two other useful functions — more favorable signal noise ratio and increased selectivity. The IF Amplifier of the Super Sky rider has been designed for permanency of adjustment under conditions of extreme changes in temperature and humidity as well as unusual mechanical vibration. When you see the new Super Sky rider you will then know why the Hallicrafters lead in communications equipment value.

FEATURES

Micrometer scale tuning inertia controlled — Calibrated band spread inertia controlled — Tone and AC ON-OFF — Beat Frequency Oscillator — A.F. Gain — R.F. Gain — 6 Position band switch — Antenna Trimmer — 6 Position selectivity control — Crystal phasing — Adjustable noise limiter — Send-Receive Switch — A.V.C.-B.F.O. Switch — Bass boost switch — Phone jack.

15 Tubes.

6 Bands for most satisfactory L/C ratio.

2 R.F. stages on bands 3 to 6.

Push-pull high fidelity, audio output.

6 Step wide range variable selectivity.

Band pass audio filter.

Wide angle "S" meter.

Phone jack.

Adequate headphone output.

Improved signal to image and noise ratio.

80/40/20/10 Meter amateur bands calibrated.

Temperature compensated high frequency oscillator.

New type inertia-controlled back-lash free dial mechanism on both main tuning and bandspread dials. This mechanism is preloaded and the main shafts are supported at both ends with ball bearings.

The chassis is removed from the front panel and firmly positioned with two brackets which support it without danger of strain or torque.

Both main tuning and band spread condensers are semi-floating and mounted to the chassis at three points.

FREQUENCY RANGE:

Band 1 — 540 to 1650 kc.

Band 2 — 1.5 to 3.2 mc.

Band 3 — 3.0 to 6.2 mc.

Band 4 — 5.5 to 12.0 mc.

Band 5 — 11.0 to 32.0 mc.

Band 6 — 21.0 to 43.0 mc.

Cabinet dimensions — 20½" long — 14½" deep — 9½" high.

The **MODEL SX-28** receiver with crystal and tubes, less speaker.....Net **\$159.50**

Hallicrafters Jensen bass-reflex enclosure including 12" speaker 30" high — 16" deep — 22½" wide **Model R12** **\$29.50**

Hallicrafters Jensen bass-reflex enclosure 8" speaker 23½" high — 10¼" deep — 17½" wide — **Model R8** **\$19.50**

the hallicrafters inc.

WORLD'S LARGEST BUILDERS OF AMATEUR COMMUNICATIONS EQUIPMENT

The New SUPER DEFIANT SX-25



A de luxe model acclaimed by amateurs all over the U. S. as the finest amateur receiver ever manufactured at anywhere near this price. It offers even better performance than that of the famed SX-17. Its general circuit is based on the proved efficiency of America's best selling receiver, the Sky rider DEFIANT.

Among its outstanding advantages are extreme selectivity with more and better audio. The design of the crystal filter makes possible critical CW operation under trying conditions of interference, and, in addition, the sensitivity of the receiver is raised from 2.8 to 4 times in the "CW Xtal" position when the receiver is tuned to the exact resonant frequency of the crystal itself; this means more usable sensitivity.

Both IF stages are expanded in the "Broad IF" position for high fidelity performance. An effective AVC or automatic volume control circuit keeps most signals at uniform audibility. The automatic noise limiter reduces interference by as much as 70%. The extremely low noise level of the SUPER DEFIANT makes it sensitive to very weak signals.

Every part is placed for best performance without regard for symmetry or beauty. Being self-contained there are no external units except the speaker. Tuning is effortless. Controls are conveniently located.

FEATURES

2 Stages of preselection.

Twelve tubes:

Overall range 540 kc to 42 mc in four bands:

- 1 — 540 kc-1700 kc.
- 2 — 1.7 mc-5.1 mc.
- 3 — 5.0 mc-15.5 mc.
- 4 — 15.1 mc-42 mc.

Separate calibrated bandsread dial for the 10, 20, 40 and 80 meter bands provides frequency meter tuning.

Oscillator compensation for frequency stability.

Automatic noise limiter.

Six-step variable selectivity covering from wide range high fidelity to extreme CW crystal.

S meter calibrated in "S" and "DB" units.

Push-pull output stage furnishes 8 watts of audio.

Front panel controls: RF Gain, Selectivity Switch, Crystal Phasing, Audio Gain, Pitch Control, Main Tuning Control, Bandsread Tuning Control, ANL Switch, Hi-Lo Tone, Send-Receive Switch and BFO Switch.

External provision for: Send-Receive Terminals, Headphones, 5000 or 500 ohm Output, Single Wire or Doublet Antenna.

Laboratory checked, piezo quartz crystal filter included as standard equipment.

Ten-inch heavy duty PM dynamic speaker in matching metal cabinet included as standard equipment.

Dimensions of receiver cabinet only: 19½" long, 9½" high, 11½" deep.

110 volt 50-60 cycle AC operation. DC operation socket provided for battery or vibrapack.

The **SUPER DEFIANT** (Model SX-25) — Complete with speaker, crystal and tubes. Shipping **\$99.50** weight 52 lbs.

Extra for Univ. 110-250 volts, 25-60 cycles...\$5.00

the hallicrafters inc.

WORLD'S LARGEST BUILDERS OF AMATEUR COMMUNICATIONS EQUIPMENT

The SKYRIDER DEFIANT

SX-24

WITH FREQUENCY METER TUNING



The Skyrider Defiant offers performance that can be favorably compared only with most receivers at twice the price. Every advanced feature of the entire Hallicrafters line is incorporated in this unit. Truly, it has all of the desirable features and qualities that are needed for outstanding amateur reception. Four bands cover the range from 545 kc to 43.5 mc; frequency meter tuning on 10, 20, 40 and 80 meter amateur bands. Tubes — 3-6SK7, 1-6K8, 1-6SQ7, 1-6F6G, 1-6H6, 1-76, 1-80. Controls include RF gain, selectivity switch, crystal phasing, audio gain, pitch control, main tuning control, bandsread tuning control, A.N.L. switch, Hi-Lo tone, send-receive switch and BFO switch. Cabinet size — 19½" long, 9½" high, 10¼" deep. For operation from 110 volt 50-60 cycle AC. For 110 volt AC operation from 6 volt DC use No. 301 Electronic Converter.

FEATURES

- One stage of preselection.
- Accurately calibrated bandsread dial throughout the amateur bands.
- Frequency stability throughout a wide range of line-voltage, humidity and temperature variations.
- DC operation socket — battery or vibrapack.
- A brand new, highly efficient, noise limiter circuit.
- Six point variable selectivity from sharp CW crystal to high-fidelity.
- Terminals provided for break-in relay operation. Single-signal crystal filter standard equipment.
- Meter calibrated in both S and DB units.

The **SKYRIDER DEFIANT** (Model SX-24) complete with tubes and crystal. **\$69⁵⁰**
Shipping weight 40 lbs. (**SKYFY**)..

The **SKYRIDER DEFIANT** (Model SC-24) — With tubes, crystal and 10" PM23 Dynamic Speaker. Shipping weight **\$81⁵⁰**
56 lbs.

Extra for Univ. 110-250 volts, 25-60 cycles.....**\$5.00**

the hallicrafters inc.

WORLD'S LARGEST BUILDERS OF AMATEUR COMMUNICATIONS EQUIPMENT

The SKYRIDER SX 23



The **SX-23** is an outstanding example of the ability of Hallicrafters engineers to produce a unit of superior efficiency offering for the first time compensated frequency stability, eliminating drift. The main feature of the new band-spread system is its reset accuracy. There is no band-set dial to fuss with. The same station always comes in at the same place on the dial. The band indicator harmonizes with the S-DB meter, and is direct reading. Tubes — 3-6SK7, 1-6SA7, 2-6SJ7, 1-6SQ7, 1-6B8, 1-6H6, 1-6F6G, 1-80. Controls, RF gain, pitch control, tone control, selectivity switch, A.N.L. switch, band switch, send-receive switch, audio gain, crystal phasing control, main tuning control and phone jack. Cabinet size — 19" long, 9 $\frac{1}{4}$ " high, 12 $\frac{1}{2}$ " deep. For operation from 110 volt 50-60 cycle AC. For 110 volt AC operation from 6 volts DC use No. 301 Electronic Converter.

FEATURES

- 8 bandswitch positions.
- Bands 1-2-3-4 cover 545 kc to 44 mc continuously.
- Bands 5-6-7-8 are pre-set band spread for the amateur 10, 20, 40, and 80 meter bands.
- Six-step variable selectivity.
- Improved noise limiter circuit.
- Frequency stability, both from temperature-humidity effects and from line voltage variations.
- "Venetian Blind" dial, band indicator and S-DB meter.
- Completely shielded crystal circuit and phasing control — permeability tuned coil — with separate shielded compartment for crystal.
- The **SKYRIDER 23** (Model SX23) — Complete with tubes and crystal. Shipping weight 56 lbs. (SKYNU) .. **\$115⁵⁰**
- The **SKYRIDER 23** (Model SX23) — Complete with tubes, crystal, 10" PM 23 Speaker..... **\$127⁵⁰**
- Extra for Univ. 110-250 volts, 25-60 cycles **\$5.00**

the hallicrafters inc.

WORLD'S LARGEST BUILDERS OF AMATEUR COMMUNICATIONS EQUIPMENT

The SKY BUDDY S-19R



The Hallicrafter engineers designed the Sky Buddy with the thought of producing a true amateur receiver in every respect. One that could be sold at a moderate price yet produce superior performance for this type of receiver. The Sky Buddy covers everything on the air from 44 mc to 545 kc, including the 10, 20, 40, 80 and 160 meter amateur bands. It now employs the same electrical bandspread system used in the higher priced Hallicrafter models. In no other similar receiver but the Sky Buddy can be found such extremely smooth and satisfactory electrical bandspread action. The stator plates are an integral part of the main condenser and the separate rotor sections are driven by a gearless mechanism through the separate bandspread knob. The Sky Buddy is equipped with conveniently arranged controls enabling the operator to realize the maximum in performance.

Read and check all the outstanding features and carefully compare the Sky Buddy with communications receivers selling at anywhere near this moderate price. When you operate, and know the exceptional sensitivity and selectivity of this unit, you too will agree to its superior performance and amazing ease of operation even under the most trying conditions.

FEATURES

- Continuous coverage, 44 mc to 545 kc.
- Plus the 10 meter band with uniform sensitivity over the entire band.
- Four bands.
- Electrical band spread.
- Illuminated band spread scale covering 360°.
- Separate band spread section condenser with ball bearing mounting.
- Built-in 5" dynamic speaker with floating rubber supports.
- Beat frequency oscillator.
- Built-in line filter.
- Six tubes with 8-tube functions.
- 6K8 Converter tube uses separate filter supply for greater stability.
- Band switch.
- AVC switch.
- Send-receive switch.
- Pitch control.
- Baked black crackle cabinet 17½" x 8½" x 8½". Amateurs' net price... **\$29.50**

the hallicrafters inc.

WORLD'S LARGEST BUILDERS OF AMATEUR COMMUNICATIONS EQUIPMENT

F M - A M

154 MC—27 MC (S-27)

Frequency Modulation
Amplitude Modulation



15 Tubes. 3 bands: 27 to 46 mc; 45 to 84 mc; 81 to 145 mc; Switch changing from FM to AM reception. Uses Acorn, 1852, and Beam Power tubes. Controls are: R.F. gain control. Band switch. Antenna trimmer. I.F. selectivity control and power switch. Volume, Pitch,

and Tone Control. S meter adj. AVC on-off and send-receive switch. Phone jack. 110 volt 50-60 cycle AC. Cabinet 19" x 9" x 14". Model S-27 complete with tubes \$175⁰⁰ (shipping wt. 75 lbs.).....



HT-9 100 WATT TRANSMITTER

A 5-frequency phone and CW unit rated at 100 watts on CW and 75 watts on phone (carrier output). Coils available for all bands from 1.7 to 30 mc. 14 tubes. 110 volt, 50-60 cycles AC. Cabinet 28" x 18 1/4" x 11 1/2". Shipping wt. 165 lbs.

MODEL HT-9—Complete with tubes, but less crystals and coils \$199⁵⁰

160-80-40 Meter coils (for operation on crystal frequency) each set, \$6.65. 20-10 Meter coils (for operation on twice crystal frequency) each set, \$8.95. 160-80-40 Meter crystals, each, \$4.80. 20 Meter crystals (for 10 meter operation), each, \$5.75.

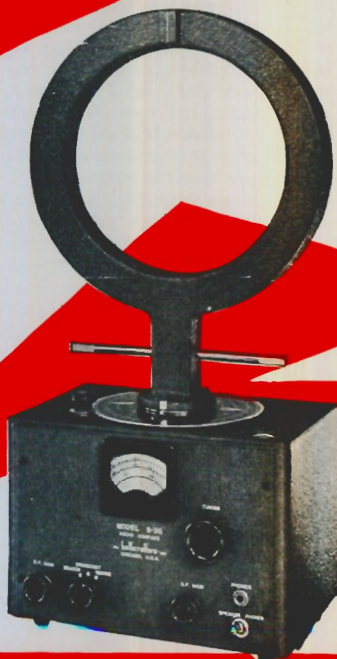

S-30 RADIO COMPASS

The model S-30 radio compass and direction finder enables you to check your position against beacon, broadcast or shore radiophone stations. 6 tubes. Coverage from 200 to 3000 kc (1500 to 100 meters) on 3 bands. Cabinet 11" x 10 5/8" x 7 1/2" (height including loop 23 1/2"). Model S-30 complete with tubes, head phones and 6 volt vibrapack power supply...net \$99⁵⁰
Separate emergency battery box completenet \$19.45

the hallicrafters inc.

WORLD'S LARGEST BUILDERS OF AMATEUR COMMUNICATIONS EQUIPMENT

HT-6 25 WATT, PHONE and CW TRANSMITTER



Experience a real sensation by operating the Hallicrafters HT-6. A transmitter which offers many advantages for the operator. Instant band-switching is provided for selection of any one of three amateur bands. The transmitter may be operated on any band from 5 to 160 meters inclusive, providing 25 watts output, except on 5 meters where it is slightly lower.

Coils for any three bands may be plugged in, pre-tuned, and then switched at will by a control on the front panel, which properly connects all circuits from crystal to antenna. Coils are available for any amateur band, 5 to 160 meters with crystal control; or with ECO on the 160, 80, 40, 20 meter bands.

A special form of oscillator keying gives a clean chirpless signal, providing for break-in operation on CW.

Any high level high impedance mike may be used, such as an Astatic type D-104 or Shure 706-SA.

Excellent voice quality with 100% modulation is assured. Output circuit is adjustable to match any load of from 10 to 600 ohms.

The entire rig including the complete audio system and power supplies is housed in a table model metal cabinet 20" x 9" x 15".

FEATURES

Frequency range 1.7 mc to 60 mc — Power drain about 120 watts CW and 225 watts phone, Tube complement: 1-6L6 Osc.-dblr., 1-807 final R.F. amplifier, 1-6F5 microphone amplifier, 1-6J5 audio amplifier, 2-6L6G modulators and 2-5Z3 rectifiers. All plug-in coil units except the final tanks include their own air tuning condensers and are individually shielded with the tuning knobs projecting through the shield cans. Cabinet dimensions 20" x 9" x 15". For operation on 110 volts 50-60 cycle AC.

MODEL HT-6 — Transmitter with tubes, less \$99.00 coils and crystals. Ship wt. 67 lbs. (TRANO)

Coils for 160, 80, 40 or 20 meter operation, each set..... **\$4.95**

E.C.O. unit for 160, 80, 40 or 20 meter operation for corresponding coils listed above, each **\$3.65**

Set of coils for 5 or 10 meter operation on twice crystal frequency, each set..... **\$6.95**

Random Frequency Crystal for 160, 80, 40 meters, each..... **\$4.80**

Random Frequency Crystal for 20, 10 and 5 meters, each..... **\$5.75**

Extra for 220 volt 50-60 cycle operation..... **\$7.50**

the hallicrafters inc.

WORLD'S LARGEST BUILDERS OF AMATEUR COMMUNICATIONS EQUIPMENT

HT-11



MARINE RADIOPHONE UNIT

FEATURES

A moderately priced complete ship to shore 11 tube radio transmitter and receiver. The ideal unit for the smaller pleasure craft who want the added safety of Radiophone. Rust proofing and corrosion protective used throughout. Rigid construction — attractively finished — compact in shape, small in size (14 $\frac{1}{8}$ " x 8 $\frac{3}{4}$ " x 9 $\frac{1}{4}$ "), light in weight.

11 tubes — Transmitter has 3 crystal controlled frequencies in the range of 2000 to 3000 kc. Receiver is manually tuned. Band No. 1 — 550 to 1700 kc. — Band No. 2 — 2 to 3 mc. — Transmitter channel switch — Receiver Band Switch — Receiver Volume Control and On-Off Switch — Receiver Tuning — Transmitter Fil. Off-On Switch — Speaker — Headphone Switch — Handset with Send-Receiver Push Button.

Complete with tubes — 110 volt AC operation — less crystal and installation, Net. \$149.50

The SKYRIDER MARINE S-22-R



Specifically designed for marine service, in the range from 16.2 to 2150 meters (18.5 mc to 110 kc). Improved image rejection at the higher frequencies is achieved through the use of 1600 KC IF Transformers. The directly calibrated main tuning dial eliminates the use of complicated charts and tables. An efficient mechanical bandspread with separate dial provides easy logging.

FEATURES

Built for 110 volt AC-DC operation. Also may be operated from 6 volt battery supply with the addition of a Model No. 301 Electronic Converter. Dimensions 18 $\frac{1}{2}$ " x 9 $\frac{3}{4}$ " x 8 $\frac{1}{2}$ " high. The SKYRIDER MARINE (Model S-22-R) — Complete with tubes and speaker. Shipping weight 31 lbs. . (SKYCU) \$64.50

the hallicrafters inc.

3611 INDIANA AVENUE, CHICAGO, U. S. A.



MILLEN MODERN PARTS



MILLEN RADIO PRODUCTS are well designed MODERN PARTS for MODERN CIRCUITS, attractively packaged, moderately priced, and fully guaranteed. They have been designed with a view toward easy and practical application as well as efficient performance. For instance, the terminals are located so as to provide shortest possible leads, mounting feet are designed for easy insertion of screws and socket contacts, so that the solder won't run down inside them and make impossible the insertion of the tube, etc. Thus our slogan, "Designed for Application." Our general catalog is available for the asking either from your favorite parts supply house or direct from the factory. Herewith we list those parts which are most generally specified in the Handbook.

11000, 12000, 13000, 14000 SERIES CONDENSERS 077" air gap is for 3000 volt peak rating					
MILLEN TYPE					
Code	Capacity per side		Air Gap	Voltage Rating	Net Price
	Max.	Mtn.			
11035	36	4.6	.077"	3000	\$5.75
11050	51	6.5	.077	3000	5.95
11070	74	9.5	.077	3000	6.50
13035	35	4.9	.077	3000	3.80
13050	49.5	6.3	.077	3000	4.35
13070	71	7.3	.077	3000	4.90
14200	204	10.7	.077	3000	6.50
14100	90.5	12.9	.171	6000	10.00
14050	50		.171	6000	6.00
14060	60		.265	9000	10.00
CONVENTIONAL SINGLE SECTION TYPE					
Code	Capacity per section		Air Gap	Finish on Plates	Net Price
	Mtn.	Max.			
12935	9	37	.176"	Polished	\$3.60
12936	9	37	.176	Plain	3.25
12536	6	43	.077	Plain	2.00
12531	7	55	.077	Plain	2.25
12576	9	76	.077	Plain	2.50
12510	12	101	.077	Plain	3.00
12515	18	151	.077	Plain	3.75
CONVENTIONAL DOUBLE SECTION TYPE					
Code	Capacity per section		Air Gap	Finish on Plates	Net Price
	Mtn.	Max.			
12035	6	43	.077"	Polished	\$3.60
12036	6	43	.077	Plain	3.25
12050	7	55	.077	Polished	4.25
12051	7	55	.077	Plain	3.60
12075	9	76	.077	Polished	5.50
12076	9	76	.077	Plain	4.50

Code	Description	Net Price
10000	Worm Drive Unit	\$3.00
10001	Drum Meter Dial-0-100	1.85
10007	1 1/4" Nickel Silver Inst. Dial-0-100	.40
10008	3 1/2" Nickel Silver Inst. Dial-0-100	.95
10050	Dial Lock	.35
10060	Shaft Locks for 1/4" Shafts	.36
10065	Variable Drive Unit	.36
20015	Steatite Ultra Midget 15 mmfd SS	.60
20035	Steatite Ultra Midget 35 mmfd SS	.75
20050	Steatite Ultra Midget 50 mmfd SS	.85
20100	Steatite Ultra Midget 100 mmfd SS	1.15
20140	Steatite Ultra Midget 140 mmfd SS	1.30
20280	Steatite Ultra Midget 20 mmfd DS	.85
20935	Steatite Ultra Midget 35 mmfd DS	.90
21050	Steatite Ultra Midget 50 mmfd SS	1.10
21100	Steatite Ultra Midget 100 mmfd SS	1.30
21140	Steatite Ultra Midget 140 mmfd SS	1.50
21935	Steatite Ultra Midget 35 mmfd DS	1.20
22075	Steatite Midget 75 mmfd SS	1.10
22100	Steatite Midget 100 mmfd SS	1.15
22140	Steatite Midget 140 mmfd SS	1.35
22915	Steatite Midget 15 mmfd DS	.85
22935	Steatite Midget 35 mmfd DS	.90
22950	Steatite Midget 50 mmfd DS	1.00
23075	Steatite Dual Midget 75 mmfd per section SS	1.89
23100	Steatite Dual Midget 100 mmfd per section SS	2.04
23925	Steatite Dual Midget 25 mmfd per section DS	1.68
23950	Steatite Dual Midget 50 mmfd per section DS	1.92
24100	100 mmfd per section, Single spaced	2.10
24935	35 mmfd per section, Double spaced	2.10
25130	93-130 Air Padder	1.25
26025	3-25 Air Padder	.80
26050	4-50 Air Padder	.90
26075	4.3-76 Air Padder	1.00
26100	5-97 Air Padder	1.10
26140	6.5-140 Air Padder	1.25
26920	4.5-20 Air Padder	.90
26935	5.5-36 Air Padder	.95
27010	10 mmfd Silver on Mica	.30
27025	25 mmfd Silver on Mica	.30
27050	50 mmfd Silver on Mica	.30
27100	100 mmfd Silver on Mica	.30

JAMES MILLEN



MFG. CO., INC.

MAIN OFFICE

AND FACTORY

MALDEN, MASSACHUSETTS, U.S.A.

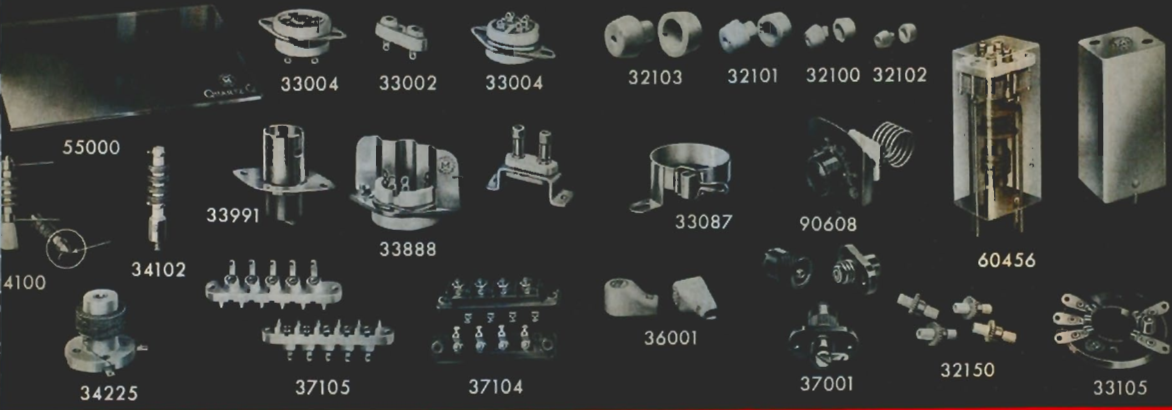

DESIGNED for APPLICATION

Code	Description	Net Price
27150	150 mmf Silver on Mica	\$.35
28030	30 mmfd Mica Padder	.15
30001	Standoff, 1/2 x 1 1/2, QuartzQ	.15
30002	Standoff, 1/2 x 2 1/2, QuartzQ	.21
30003	Standoff, 3/4 x 2 1/2, QuartzQ	.55
30004	Standoff, 3/4 x 4 1/2, QuartzQ	.65
31001	Standoff, 1/2 x 1, Isolantite	.12
31002	Standoff, 1/2 x 2 1/2, Isolantite	.18
31003	Standoff, 3/4 x 2, Isolantite	.30
31004	Standoff, 3/4 x 3 1/2, Isolantite	.42
31011	Cone, 3/4 x 1/2, Steatlite	.05
31012	Cone, 1 x 1, Steatlite	.15
31013	Cone, 1 1/2 x 1, Steatlite	.21
31014	Cone, 2 x 1, Steatlite	.27
31015	Cone, 3 x 1 1/2, Steatlite	.45
31017	Cone with base and jack, 1 1/4" high, Steatlite	.30
31018	Cone with base and screw top, 1 1/4" high, Steatlite	.21
32100	Stearlite Bushing for 3/4" hole	.30
32101	Stearlite Bushing for 1/2" hole	.35
32102	Stearlite Bushing for 3/4" hole	.20
32103	Stearlite Bushing for 1/2" hole	.45
32150	Isolantite Thru-bushing, for 1/4" hole	.05
33002	Crystal Socket	.25
33004	4 Prong Socket	.24
33005	5 Prong Socket	.24
33006	6 Prong Socket	.24
33007	7 Prong, Large, Socket	.34
33008	8 Prong, Octal, Socket	.24
33087	Base Clamp for 807 etc.	.30
33105	Acorn Socket, QuartzQ	.90
33888	Aluminum Shield for 33008	.18
33991	Socket for 991 etc.	.45
34010	Shielded 10 MH receiving	.60
34100	Universal 2.5 MH	.36
34101	Universal 2.5 MH, less Standoff	.30
34102	Commercial type 2.5 MH	.36
34140	Universal air core Transmitting	1.00
34150	Amateur Band Iron Core	1.75
34210	General Purpose RFC 10 MH	.30
34225	General Purpose RFC 25 MH	.35
34240	General Purpose RFC 40 MH	.40
34285	General Purpose RFC 85 MH	.50
34800	Interruption Frequency Oscillator Coil	.90
36001	Ceramic Plate Cap, 9/16" for 866 etc.	.21
36002	Ceramic Plate Cap, 3/4" for 807 etc.	.21
37001	Black Bakelite Safety Terminal	.35
37104	Four Terminal, Black Bakelite	.55
37105	Five Terminal, Steatlite	.45
37202	Stearlite Plates, Pr.	.21
37211	Bracket	.15
37222	Terminal Posts, Pr.	.30
37501	Low Loss Mica Bakelite Safety Terminal	.45
38001	Isolantite 3/16" O.D. Beads (Pk of 50)	.30
38500	100 Beads, 5/16" dia., QuartzQ	.60
39001	Truly Flexible Isolantite	.36
39002	Conventional	.36
39003	Solid Brass N.P.	.15
39005	Universal Joint, Non-Insulated	.36
39006	Slide Action	.36
40205	Midget Plug	.24
40305	Intermediate size plug	.45
41205	Midget Socket	.30
41305	Intermediate size socket	.45
43001	QuartzQ blank form and plug	.90
43011		.90
43021	center link, No. 2, ead link	.90
43041	plug, No. 1 at end of code means	.90

Code	Description	Net Price
43081	Midget coils for each	\$.30
43161	band. Mounted on No. 40205	.90
44000	QuartzQ form 1 1/4" dia. x 3 3/4"	.75
44001	QuartzQ blank form and plug	1.20
44005		1.50
44010		1.50
44020		1.50
44040	"100 watt" coils	1.50
44080	for each band. Mounted on	1.90
44160	No. 40305 plug.	2.10
44500	Swinging link and socket	1.75
45000	Coll Form, 1" dia. no p., low loss mica base Phenolic	.21
45004	Coll Form, 1" dia. 4 p., low loss mica base Phenolic	.30
45005	Coll Form, 1" dia. 5 p., low loss mica base Phenolic	.30
45500	Coll Form, 3/4" dia., Steatlite	.45
46100	Coll Form, 1 1/4" dia. no p., QuartzQ	.45
47001	Coll Form, 1/2" dia., QuartzQ	.10
47002	Coll Form, 3/4" dia., QuartzQ	.15
47003	Coll Form, 1/2" dia., QuartzQ	.35
47004	Coll Form, 3/4" dia., QuartzQ	.35
55001	Sheet, 3 x 8 1/2 x 1, QuartzQ	.35
58000	Coll Dope, 2 oz., QuartzQ	.30
77083	"83" Hash Filter 250MA	1.00
77886	"866" Hash Filter 500MA	1.25 pr.
77872	"872" Hash Filter	1.40 pr.
79020	14mc Band Wave Trap	.75
79040	7mc Band Wave Trap	.75
79080	3.5mc Band Wave Trap	.75
79160	1.7mc Band Wave Trap	.75
<i>Air Trimmed</i>		
60454	456 Diode Air Core	2.75
60455	456 Interstage (1) Air Core	2.75
60456	456 Interstage (2) Air Core	2.75
60501	5000 Interstage (2) Air Core	2.75
60502	5000 Diode Air Core	2.75
60503	5000 FM Interstage Air Core	3.00
60504	5000 FM Disc Air Core	3.00
62161	1600 Interstage Iron Core	3.00
62162	1600 Diode Iron Core	3.00
62454	456 Diode Iron Core	3.00
62456	456 Interstage Iron Core	3.00
63163	1600 BFO Air Core	2.50
63456	456 BFO Air Core	2.50
63503	5000 BFO Air Core	2.50
<i>Mica Trimmed</i>		
67454	456 Diode Iron Core	1.25
67456	456 Interstage Iron Core	1.25
67503	5000 FM Interstage Air Core	1.50
67504	5000 FM Disc Air Core	1.50
<i>Permeability Tuned</i>		
64454	456 Diode (2)	1.35
64456	456 Interstage (2)	1.35
65456	456 BFO	1.35
<i>Triple Tuned</i>		
66454	456 Diode	1.75
66456	456 Interstage	1.75
90500	Complete set of four, in case	6.50
90605	Range 2.5 to 9.7 mc.	1.65
90606	Range 9.0 to 28 mc.	1.65
90607	Range 26 to 55 mc.	1.65
90608	Range 50 to 140	1.65
90721	Hetrodi	3.50

JAMES MILLEN MFG. CO., INC.



MAIN OFFICE AND FACTORY

MALDEN, MASSACHUSETTS, U.S.A.

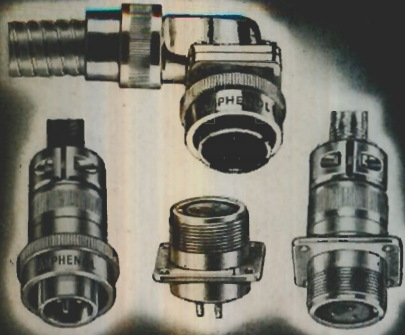

ARMY - NAVY 9534 SPECIFICATION CONNECTORS

Connectors for radio and electrical work, with conduit fittings and accessories, are now available in arrangements from 1 to 45 contacts and ratings from 2 to 200 amperes. Designed for maximum interchangeability, wherein 60 different insulating bakelite elements can be adapted to four styles of metal housings in both straight and chassis types as well as 90° angle fittings. Specified for Army and Navy work, but equally desirable for broadcasting hook-ups and industrial or marine use.

AMPHENOL "912-A" and "912-B"

912-A — Transparent Polystyrene — is the world's finest insulating material for high and ultra-high frequency use. Best for high frequency circuits, providing temperatures in excess of 190° F. are not encountered. Available in rods and squares for machining, liquid form for coil dipping, or molded into finished products such as octal, loktal, miniature, and crystal-holder sockets, coil forms, insulators, co-axial cable insulating beads, alignment tools, and other accessories. Moisture absorption nil. At 1,000,000 cycles, power factor is 0.00025 and dielectric constant 3. Tensile strength, 5,500 — 7,000 pounds per square inch.

912-B is a transparent synthetic resin product, a mechanically strong insulating material. Being a thermo-plastic, it can be heated to 212° F., at which point it becomes soft and pliable and readily formable into any desired shape. As it is a good transmitter of light, bent rods are often used in medical diagnostic instruments, while rings around the perimeter of instrument panels provide diffused lighting. Available in sheets, rods, tubing, or thin film.

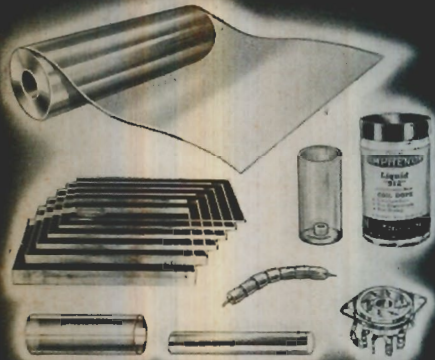

CO-AXIAL CABLE and ACCESSORIES

For radio antenna and high frequency leads in transmitters, receivers, public address systems, television, sensitive measuring devices, etc. Insulated with pure polystyrene beads. Exceptionally loss free. Manufactured in many sizes for both outdoor and indoor use. Shielding of braided flexible wire, copper tubing, or flexible metal covering. Connectors, shield clamps, terminals, etc., for installation available. Our engineers will help with your problems.

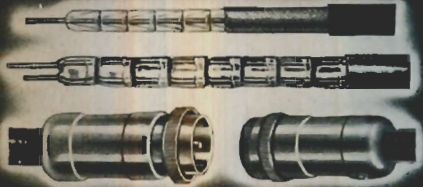

STEATITE PRODUCTS

Newly developed Steatite meets U. S. government specifications, is non-hygroscopic, and has a lower loss-factor than ordinary Steatite. Amphenol Steatite sockets are recommended for high frequency work where high temperatures are encountered, in transmitters and amplifiers where the output is in excess of 20 watts, for plug-in coil, crystal, and transformer receptacles. New design gives maximum contact insulation and extremely long leakage paths.

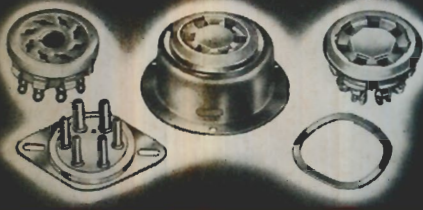

BAKELITE PRODUCTS

Amphenol precision-built bakelite sockets, plugs, and connector inserts for radio applications are the most widely known and most complete line in the industry. A socket for every tube. Both shielded and unshielded types are manufactured in a wide variety of mounting assemblies. Power plugs and sockets, microphone and other special connectors, switches, and convenience outlets are available over a wide range of contact arrangements.



ORDER YOUR FREE AMPHENOL CATALOG TODAY

AMERICAN PHENOLIC CORPORATION

1250 VAN BUREN STREET, CHICAGO, U. S. A.

There MUST Be a Reason for PAR-METAL PREFERENCE!

So many Amateurs who build their own rigs use Par-Metal

CABINETS, CHASSIS RACKS and PANELS

that there must be a reason for such outstanding preference.

Par-Metal parts are easy to use for you can assemble them and interchange them almost at will. That's because they are accurately machined. They are modern in design, streamlined, chromium trimmed, equipped with modern hardware, handsomely finished for lasting beauty.

You may contemplate a simple rig or a complete transmitter or Sound System — whatever the job you'll find that Par-Metal Parts will give the finished job a professional and commercial appearance that wins admiration.

KEEP OUR CATALOG HANDY!

If you do not have your copy of our catalog No. 40 get one from your jobber or write us today. It lists the complete Par-Metal Line of Standard and De Luxe Models — everything that you could possibly need for the job you intend to build!

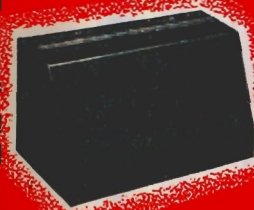

PAR-METAL PRODUCTS CORP.

3268 — 49th STREET • LONG ISLAND CITY, NEW YORK

Export Dept: 100 Varick Street, New York, N. Y.

BLILEY



40 METERS
TYPE B5



80-160 METERS
TYPE LD2



STANDARD FREQUENCY
100KC. CRYSTAL UNIT
TYPE SOC100



40-80-160 METERS
TYPE BC3

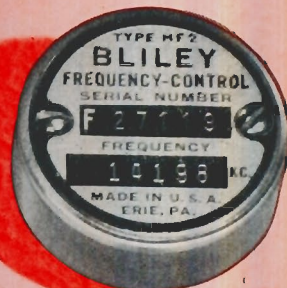

10-20 METERS
TYPE HF2

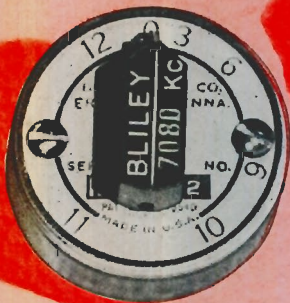

40-80 METERS
VARIABLE FREQUENCY
TYPE VF1



STANDARD FREQUENCY
100KC. CRYSTAL UNIT
TYPE SOC100X

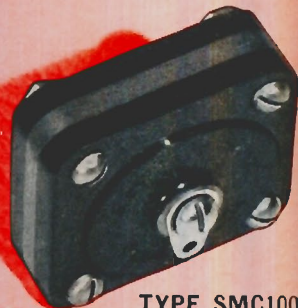

TYPE SMC100
CALIBRATOR CRYSTAL UNIT
100KC.—1000KC.

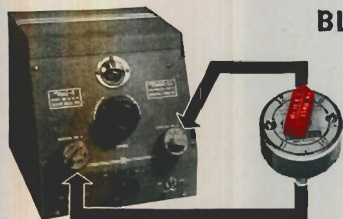

BLILEY VARI-X VARIABLE CRYSTAL OSCILLATOR WITH VF2 CRYSTAL UNIT

Frequency selection is easy with the Vari-X and wide range VF2 Variable Crystal Units. And, you can forget worries about frequency stability (so difficult to obtain with a self-excited oscillator) because the Vari-X is 100% crystal controlled. Circular D2, obtainable from your Bliley Distributor, gives complete information.

CRYSTALS

TYPE B5

Thoroughly engineered in every detail, this compact unit represents the best in a mounted, low-drift, high-frequency quartz crystal. Each crystal is manufactured under rigid standards and has a maximum temperature coefficient of ± 4 cycles/mc./°C.

Price—7.0 to 7.3mc., within
 ± 5 kc. of specified kc.* . \$4.80
 —at specified integral kc. . \$5.90

TYPE BC3

This popular, economically priced crystal unit is fully reliable in every respect. The accurately cut crystal has a high activity with a frequency drift of only 23 cycles/mc./°C. Heat, developed by the crystal, is dissipated by the stainless-steel holder cover-plate thereby reducing actual frequency drift.

Price—40 or 80-meter band,
 within ± 5 kc.* \$3.35
 —at specified integral kc. . \$4.95
 Price—160 meters, within ± 10 kc. \$3.35

TYPE VF1

Avoid QRM by frequency selection. The frequency of the VF1 Variable Frequency Crystal Unit is continuously variable up to 6kc. with the 80-meter unit, or 12kc. with the 40-meter unit. When multiplying, the range is proportionately increased. The specially finished crystal has a drift of less than ± 4 cycles/mc./°C. and an activity only somewhat less than that of high activity fixed-frequency crystals.

Price—40-meter band, minimum
 frequency within ± 15 kc.
 of specified \$6.60
 —within ± 5 kc. \$8.50

Price—80-meter band, minimum
 frequency within ± 5 kc. . \$6.60
 Price—at specified integral kc. . \$8.50

TYPE LD2

The outstanding crystal unit for the 80 and 160-meter bands. It incorporates a powerful, highly active crystal with a frequency drift of less than ± 4 cycles/mc./°C. Correctly designed and carefully manufactured, this time-proven unit provides accurate, dependable frequency control.

Price—within ± 5 kc. of specified kc.* \$4.80
 Price—at specified integral kc. . \$5.90

Engineering Bulletin E-6, FREQUENCY CONTROL WITH QUARTZ CRYSTALS, is a handbook on crystal control. Price, 10¢ (Canada and foreign, 15¢). Descriptive catalogs of Bliley Crystal Units are available at no charge.

TYPE HF2

Crystal control of 2½, 5, 10, and 20-meter transmitters is simplified by the use of the type HF2 High Frequency Crystal Unit. Frequency drift is ± 20 cycles/mc./°C. for the 20-meter unit and ± 43 cycles/mc./°C. for the 10-meter unit.

Price—14.0 to 14.4mc., within
 ± 15 kc. of specified kc.* . \$5.75
 Price—14.4 to 15.0mc., within
 ± 30 kc. of specified kc.* . \$5.75
 Price—28.0 to 30.0mc., ± 50 kc. of
 specified kc. (recommended
 for 2½ and 5 meters only) . \$5.75

TYPE SMC100

Frequency checking, calibrating receivers and signal generators, or performing general frequency measurements is easy with a 100kc.—1000kc. frequency standard. A few stock parts and an SMC100 Dual-Frequency Crystal Unit is all that's needed for construction.

Price \$7.75

TYPE CF1

The Bliley CF1 Crystal Filter Unit, with its high Q and freedom from spurious responses, assures maximum receiver selectivity and minimum signal loss.

Price—456kc., 465kc. or
 500kc. I-F. \$5.50
 Price—1600kc. I-F. \$9.50



TYPE SOC100

This precision-manufactured, knife-edge mounted, 100kc. bar is designed for use in primary or secondary standards of frequency where high stability and accuracy is essential. The crystal has a maximum temperature coefficient of ± 3 cycles/mc./°C.

Price—calibrated at room temp. . \$15.50
 Price—at specified oven temp. . \$21.00

TYPE SOC100X

A knife-edge mounted 100kc. X-cut bar for applications not requiring the high accuracy and stability of the SOC100 Unit. Temperature coefficient is $(-)$ 10 cycles/mc./°C.

Price—calibrated at room temp. . \$9.50
 Price—at specified oven temp. . \$15.00

Quartz crystals for frequency control and special applications are manufactured for all frequencies from 20kc. to 30mc. Bliley Broadcast Frequency Crystals are approved by the F. C. C. Ask for Catalog G-12.

All prices shown are net in U. S. A.

*Or choice from dealer's stock

LEARN CODE *the way you will use it—* BY HEARING IT

G. L. AUTOMATIC SENDERS will—
Teach You Code—Speed-up Your Receiving—
Send Your Messages

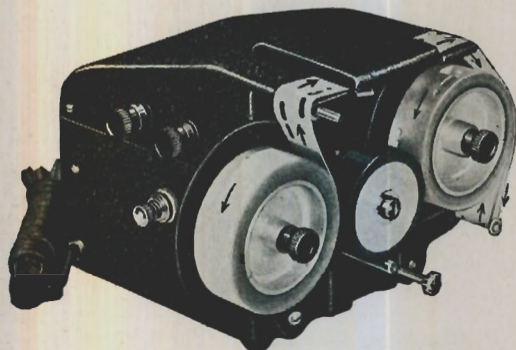

Type S — \$17.50

Sends from 4 to 60 words per minute. Higher speeds if desired. Slow enough for the beginner. Fast enough to speed-up the professional or the "Ham." Multiple brush type contacts—positive at all speeds—no misses. Silent induction type motor. Motors other than standard voltage and frequency available at slight additional cost. Only $5\frac{1}{2}$ " x $4\frac{1}{2}$ " x 6". Weighs only 4 lbs. Aluminum case, black instrument finished. All exposed parts cadmium plated. Complete with 10 rolls of double-perforated lesson tape of carefully arranged and selected material for speediest results.

Type J — \$12.50

Double purpose instrument — code teacher and automatic sender. Sends from 6 to 60 words per minute. Multiple brush type contacts — positive at all speeds. Silent induction type motor. Motors other than standard voltage and frequency available at slight additional cost. Built-in tape perforator. Cut your own code practice and reception speed-up tapes. Cut your own message tapes for calling stations or repeating messages. Repeats calls or messages indefinitely. Length of message practically unlimited. Complete with ready cut practice tape and 5 rolls of blank tape.

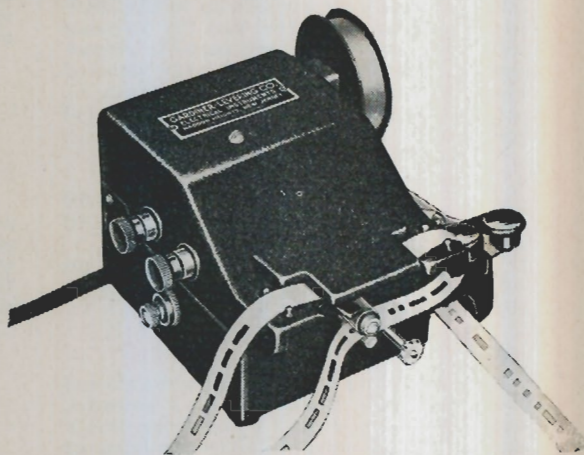

High-Speed Relay

Moisture-proof. Extremely quiet. Pin-type base. Will follow accurately at faster than 7000 per minute. Available in 6, 25, 50, 100 and 150 volts, D. C.

Information and prices on request

Tape Perforator

For making your own practice tapes. Uniform spacing and characters. Cut your own material for speeding-up reception.

Information and prices on request

Tape Puller

For almost every purpose where pulled tapes are used. Available in practically any and every speed range. For tapes from $\frac{3}{8}$ " to $1\frac{1}{2}$ ". Write us about your tape pulling problems.

Information and prices on request

If your dealer cannot supply you, write us

GARDINER-LEVERING CO.

Box 83, Haddon Heights

New Jersey, U. S. A.



BETTER
FIXED *and* VARIABLE
RESISTORS
for All Applications

Catalog on request

INTERNATIONAL RESISTANCE CO.

401 N. BROAD ST., PHILADELPHIA, PA.



HAMMARLUND



"HQ-120-X" AMATEUR RECEIVER

THE HAMMARLUND "HQ-120-X" meets the most critical demands of amateur and professional operators. Hammarlund engineers have gone beyond ordinary practice in designing this new and outstanding receiver. This ultra-modern 12-tube superheterodyne covers a continuous range of from 31 to .54 mc. (9.7 to 555 meters) in six bands, taking in all important amateur, communication, and broadcast channels. The "HQ-120-X" is not to be confused with modified broadcast sets. Two years were required to develop it. This is a special receiver with special parts throughout. Every wave range is individual — that is, each range has its own individual coil and a tuning condenser of proper value for maximum efficiency; thus, including the broadcast band does not decrease efficiency at high frequencies. Besides having all the necessary features for perfect short wave reception, such as A.V.C., beat oscillator, send-receive switch, phone jack and relay terminals, the "HQ-120-X" also includes a new and outstanding crystal filter circuit which is variable in 6 steps from full band-width to razor edge selectivity. This permits the use of the crystal

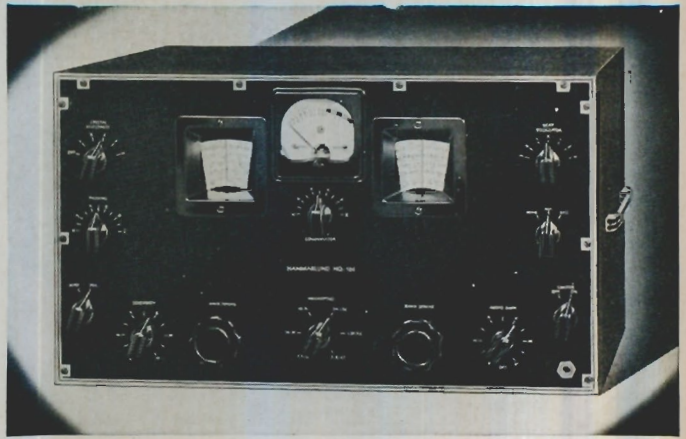

filter for the reception of both voice and music. It is no longer necessary to contend with serious heterodyne interference. These annoying disturbances can be phased out with the phasing control on the panel. Other features include drift compensation for improved stability; a new and accurate "S" meter circuit for measuring incoming signal strength; antenna compensator to compensate for various antennas, and 310 degrees band spread for each amateur band from 80 to 10 meters. The band spread dial is calibrated in megacycles for each of these amateur bands. The main tuning dial is calibrated in megacycles throughout the entire range of the receiver. Rack adapter \$6.00 extra.

Prices include Speaker and Tubes

Code	Type	Tuning Range	Speaker	Net Price
HQ-120-X	Crystal	31 — .54 mc.	10" P.M. Dyn.	\$138.00
Speaker cabinet (metal) 12½" x 12½" x 7 inches				3.90

Special model finished in gray.....\$141.00 Net
Speaker Cabinet, gray to match..... 4.50 Net

Send for Descriptive Booklet!



NEW "SUPER-PRO"

THIS new 18-tube "SUPER-PRO" includes all the outstanding features which have made the "Super-Pro" famous, and in addition many recent developments have been added. The new "Super-Pro" has a variable selectivity crystal filter. This crystal filter has five positions of selectivity — 3 for phone and 2 for CW. The variable crystal filter, in addition to the variable band width I.F., provides a selectivity range of from less than 100 cycles to approximately 16 kc. The new "Super-Pro" also has an improved noise limiter designed to minimize interference caused by automobile ignition systems and disturbances of similar nature. Maximum image suppression is obtained with two stages of high selectivity tuned R.F. ahead of the first detector. Three stages of I.F. are employed and there are three stages of high fidelity audio amplification resulting in an output of approximately 14 watts. A new and improved "S" meter has been installed in the "Super-Pro" for accurately reporting relative signal strength. Other features include full band-spread on all bands; beat oscillator; send-receive switch; relay connections; phone connections; connections for phono-pickup; beautifully finished modernistic cabinet. The sensitivity of the "Super-Pro" is better than 1 microvolt. Available in rack mounting type at \$10.50 extra.

Write for Circular!

Code	Type	Spkr.	Tuning Range	Net Price
SP-210-X	Crystal	10"	15 — 560 meters	\$279.00
SP-210-SX	Crystal	10"	7½ — 240 meters	279.00
SP-220-X	Crystal	12"	15 — 560 meters	294.00
SP-220-SX	Crystal	12"	7½ — 240 meters	294.00
PSC	10" speaker cabinet to match receiver			5.10

Special Models Covering Other Wave Ranges Available On Order

HAMMARLUND MANUFACTURING CO., INC., 424-438 West 33rd Street, New York City

"TC" TRANSMITTING CONDENSER

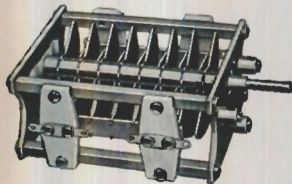

An entirely new moderately priced, heavy duty transmitting condenser, featuring heavy aluminum end plate, Isolantite insulation, non-inductive, self-cleaning silver plated beryllium contacts, full floating rotor bearing, non-magnetic rotor assembly, polished heavy aluminum plates accurately spaced. All, except type "L", have round edge plates of .040" thickness. Type "L" has .025" plates with plain edges. Type "F" has .230" 7500 V. air gap. Type "G", .200", 6750 V. Type "H", .171", 6000 V. Type "J", .100", 4950 V. Type "K", .084", 3750 V. Type "L", .070", 2000 V. air gap.

Available in a wide variety of capacities and working voltages, these condensers are ideal for modern up-to-date transmitters with power outputs ranging from 200 watts to 1 kw.

Type	Capacity	Overall Length	List
TC-220-L	220 mmf.	4 1/2"	\$ 4.50
TC-440-L	465 mmf.	5 1/2"	7.79
TC-90-K	95 mmf.	2 1/2"	4.50
TC-165-K	167 mmf.	4 1/2"	6.50
TC-220-K	222 mmf.	4 1/2"	8.00
TC-330-K	335 mmf.	6 1/2"	10.00
TC-240-J	250 mmf.	6 1/2"	10.20
TC-25-H	23.5 mmf.	2 1/2"	3.50
TC-50-H	53 mmf.	4 1/2"	6.00
TC-110-H	115 mmf.	6 1/2"	9.00
TC-40-G	46 mmf.	4 1/2"	7.00
TC-65-G	75 mmf.	5 1/2"	8.80
TC-100-G	110 mmf.	7 1/2"	11.20
TC-150-G	165 mmf.	10 1/2"	14.80
TC-55-F	60 mmf.	5 1/2"	8.00

"TCD" SPLIT STATOR TYPES



These split-stator transmitting condensers are identical to the singles shown above, except that the stator sections are individual. Ideal for push-pull power amplifiers ranging in power up to 1 kw.

They are of convenient size and lend themselves to construction of compact apparatus. Overall dimensions in back of panel are given in the accompanying table. The capacity values listed are for each section. The last letter in the code represents plate spacing and voltage ratings. These are identical to those given above. Type "M" — plain plates, .030" air gap.

Type	Capacity	Overall Length	List
TCD-500-M	490 mmf.	4 1/2"	\$ 6.50
TCD-80-L	90 mmf.	4 1/2"	5.50
TCD-210-L	215 mmf.	5 1/2"	8.25
TCD-90-K	95 mmf.	4 1/2"	7.50
TCD-165-K	167 mmf.	6 1/2"	11.00
TCD-325-K	335 mmf.	11 1/2"	20.50
TCD-240-J	250 mmf.	11 1/2"	19.00
TCD-50-H	53 mmf.	6 1/2"	9.80
TCD-110-H	115 mmf.	11 1/2"	16.00
TCD-40-G	46 mmf.	7 1/2"	10.50
TCD-75-G	85 mmf.	11 1/2"	14.50
TCD-55-F	60 mmf.	11 1/2"	13.50

"N" NEUTRALIZING CONDENSERS



Improved neutralizing condensers with heavy polished aluminum plates. Rounded edges. Isolantite. Fine adjusting screw. Positive lock. Horizontal adjustment. Type "N-10", 8 3/8" high x 1-3/16" deep. "N-15" 4-15/16" high x 3 1/2" deep. "N-20", 5-11/16" high x 4" deep.

Code	List
N-10 — (2.1 — 10 mmf.)	\$3.00
N-15 — (3.2 — 14 mmf.)	6.00
N-20 — (3.8 — 14 mmf.)	8.50

"MTC" TRANSMITTING CONDENSERS

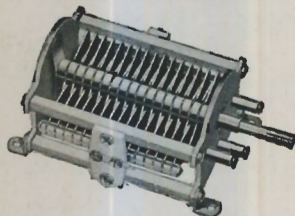

Compact types, Isolantite insulation. Base or panel mounting. Polished aluminum plates. Stainless steel shaft. Size of 150 mmf. with .070" plate spacing only 4 5/8" behind panel. All type "B" condensers have round edge plates .025" in thickness. Type "C" has plain edge plates .025" thick. Self-cleaning wiping contact.

Code	Capacity	List
MTC-20-B	22 mmf.	\$3.25
MTC-35-B	33 mmf.	3.50
MTC-50-B	50 mmf.	3.90
MTC-100-B	100 mmf.	5.00
MTC-150-B	150 mmf.	6.10
MTC-50-C	46 mmf.	2.80
MTC-100-C	105 mmf.	3.05
MTC-150-C	150 mmf.	3.20
MTC-250-C	255 mmf.	3.60
MTC-350-C	360 mmf.	4.00

"MTCD" SPLIT-STATOR TYPES

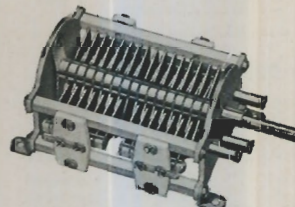

Some outstanding features as MTC singles except that stator sections are separate. Model 100-B with .070" plate spacing, only 5 3/4" behind panel. "B" models — rounded plates "C" models — plain plate edges.

Code	Capacity	List
MTCD-20-B	22 mmf. per sect.	\$5.25
MTCD-35-B	33 mmf. per sect.	5.75
MTCD-50-B	50 mmf. per sect.	6.50
MTCD-100-B	100 mmf. per sect.	8.75
MTCD-50-C	46 mmf. per sect.	4.50
MTCD-100-C	105 mmf. per sect.	5.00
MTCD-150-C	150 mmf. per sect.	5.25
MTCD-250-C	255 mmf. per sect.	6.00

A NEW LINE OF TRANSMITTING AND RECEIVING CONDENSERS

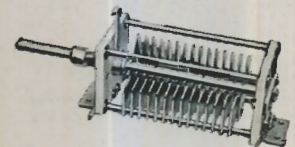
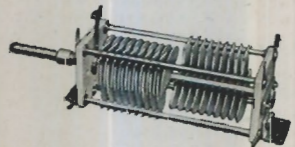

The new HFA and HFB receiving and transmitting condensers are the latest in condenser design. The HFB transmitting condenser, for example, has fully insulated rotor and control shaft permitting higher operating voltage for a given plate spacing. This new design results in more compact and efficient condenser construction and the insulated control shaft reduces the danger of electric shock to the operator. The HFB's are made in both dual and single stator types and in all important capacities.

The HFA receiving condenser is a sturdier midge condenser intended for use in portable and aviation equipment where conditions of operations demand a better and more solid condenser. These, too, are available in a wide variety of size with both single and dual stators. All types, both HFA and HFB are of 100% soldered construction with brass plates, cadmium plated, Isolantite end plates.

Send for Latest Catalog!

for those who want the best

Ultra-high-frequency triodes

U-H-F oscillator, R.F. amplifier and detector having extremely low capacitances and short leads resulting in efficient operation up to 300 megacycles (1 meter).



HY615 \$2.00 net

Heater.....6.3 volts @ 0.15 ampere
Plate.....300 max. volts & 20 max. ma.
Plate dissipation.....3.5 max. watts
R.F. power output @ 240 mc.
4.0 approx. watts

HY114 \$2.00 net

Low-drain filament-type triode for portable and mobile uses powered from batteries.

Filament.....1.4 volts @ 0.12 ampere
Plate.....180 max. volts & 15 max. ma.

Medium-power triode with cylindrical graphite anode, helical filament, vertical-bar tantalum grid. Provides unusually-high power output with minimum input.

HY75 \$3.75 net

Filament.....6.3 volts @ 2.5 amperes
Plate.....450 max. volts & 100 max. ma.
Plate dissipation.....15 max. watts

Output	Modulated	Unmodulated	
224 Mc.....	14.....	17.....	watts
112 Mc.....	19.....	24.....	watts
56 Mc.....	24.....	33.....	watts



R.F. beam-power tetrodes

R.F. power amplifier, buffer, frequency multiplier, oscillator, Class AB2 modulator of exceptionally high power sensitivity. Fully shielded for R.F. — no neutralizing required.

HY61/807 \$3.50 net

Heater.....6.3 volts @ 0.9 ampere
Plate.....600 max. volts & 100 max. ma.
Plate dissipation.....25 max. watts
R.F. power output.....37.5 approx. watts

HY60 \$2.50 net

Low-power version of HY61 with reduced power drain — ideal for mobile uses.

Heater.....6.3 volts @ 0.5 ampere
Plate.....425 max. volts & 60 max. ma.



Instant-heating tetrode

Instantaneous-heating filament type R.F. and audio tetrode for mobile and portable transmitters — no battery drain during stand-by. Shielded for R.F. Full plate input for phone and doubler operation. Also operates efficiently on AC.

HY69 \$3.50 net

Filament.....6.3 volts @ 1.5 amperes
Plate.....600 max. volts & 100 max. ma.
Plate dissipation.....40 max. watts
Nominal Class C output.....42 approx. watts



Graphite-anode triodes

High-efficiency SPEER graphite-anode triodes for R.F. Class B and C amplifier, buffer, doubler, oscillator, Class B modulator.



HY51A-HY51B \$4.50 net

HY51A filament.....7.5 volts @ 3.5 amperes
HY51B filament.....10 volts @ 2.25 amperes
Plate.....1000 max. volts & 175 max. ma.
Plate dissipation.....65 max. watts
Class C output at 75% efficiency.....131 watts

HY51Z \$4.50 net

Zero-bias version of HY51A for all applications

Filament.....7.5 volts @ 3.5 amperes
Class C output @ 75% efficiency.....131 watts



Mercury-vapor rectifiers

Half-wave mercury-vapor rectifier with internal shield to prevent bombardment of elements.

866 \$1.50 net

Filament.....2.5 volts @ 5 amperes
AC plate voltage.....2650 max. volts
Two Hytron 866's will deliver up to 2385 volts DC at currents up to 500 milliamperes.

Junior rectifier for light-duty applications with plate connection to top cap.

866 Jr. \$1.05 net

Heater.....2.5 volts @ 3.0 amperes
AC plate voltage.....1250 max. volts
DC plate current.....250 max. ma. for two tubes



HY40 \$3.50 net

Filament.....7.5 volts @ 2.25 amperes
Plate.....1000 max. volts & 115 max. ma.
Plate dissipation.....40 max. watts
Class C output at 75% efficiency.....86 watts

HY40Z \$3.50 net

Zero-bias high- μ triode similar to HY40 in ratings — particularly desirable as modulator.

Filament.....7.5 volts @ 2.5 amperes
Class C output @ 75% efficiency.....86 watts



Twin triode

Instant-heating thoriated-tungsten zero-bias twin-triode for use as modulator in mobile transmitters — designed as a companion to the HY69.

HY31Z \$3.50 net

Filament.....6.3 volts @ 2.5 amperes
Plate.....500 max. volts & 150 max. ma.
Plate dissipation.....30 max. watts
Audio power output.....50 watts
Above ratings are for both sections of tube.



HY30Z \$2.50 net

A real 25-watt transmitting tube with over-size graphite-anode and lava insulators — definitely not an overgrown receiving tube.

Filament.....6.3 volts @ 2.25 amps.
Plate.....850 max. volts & 90 max. ma.
Plate dissipation.....30 max. watts
Class C output at 75% efficiency
58 watts



Hytron transmitting tubes are fully licensed for protection of the buyer or user.

Ceramic-base Bantams and 6L6GX

6A8GTX converter.....	\$.95 net
6J5GTX med. mu triode.....	\$.95 net
6J7GTX r.f. pentode.....	\$.95 net
6K7GTX r.f. pentode.....	\$.95 net
6K8GTX converter.....	\$1.30 net
6SA7GTX converter.....	\$1.05 net
6SJ7GTX r.f. pentode.....	\$1.05 net
6SK7GTX.....	\$1.05 net
6L6GX.....	\$1.25 net

Specially-selected tubes with low-loss ceramic base for use in high-frequency circuits. Interchangeable with metal and G types.



HYTRONIC



LABORATORIES

A DIVISION OF THE HYTRON CORP.

72 Lafayette St., Salem, Mass.

ABOVE RATINGS FOR CONTINUOUS-SERVICE OPERATION

THE RECEIVER BUY OF THE SEASON!

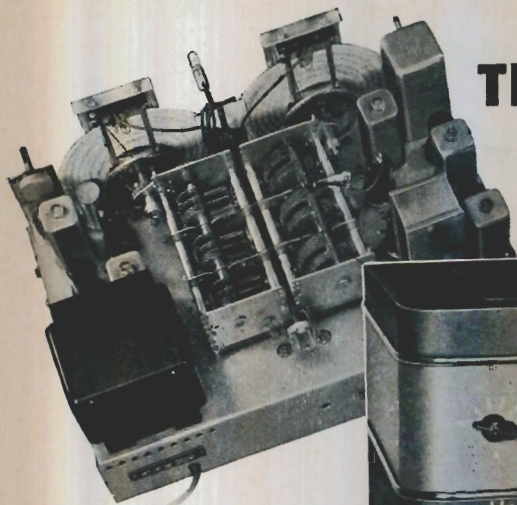

AR-77

COMMUNICATION RECEIVER



Double-Purpose Value

During off periods of "QSO-ing", when you are busy experimenting or just relaxing, you will want some good entertainment programs. To meet this extra requirement, we offer a new Extended Range Loudspeaker MI-8314-A for the AR-77. A combination hard to beat for faithful reproduction of all modulated signals. Dimensions of the MI-8314-A Speaker are: 28" high, 18½" wide, 13" deep.

Amateurs' Net Price for both AR-77 Receiver and MI-8314-A Speaker \$154.50

"STAY-PUT" TUNING

Tests under average conditions show maximum drift at 30 Mc to be only 3.0 Kc on one hour run, thereby keeping signal audible.

ADJUSTABLE NOISE LIMITER

Can easily be regulated to meet local conditions. Easily understood signals obtained through noise peaks hundreds of times higher than signal level.

"BREAK-IN" OPERATION

Used on a separate antenna, receiver recovers instantly when transmitter key is up. Ideal for "traffic hounds" to move a hook full of messages promptly. (Receiving antenna should resonate in higher frequency band than transmitter frequency to prevent excessive voltage pick-up from transmitter.)

HIGHEST SIGNAL-TO-NOISE RATIO

A 2-to-1 ratio of signal-to-noise is obtained at an average sensitivity of 2 microvolts throughout range.

Give it a Whirl!

Other AR-77 features include Uniview dials; accurate signal reset; standby switch with relay terminals; temperature and voltage compensated oscillator; high-gain pre-selector stage and a popular tuning range of 540 to 31,000 Kc. Write for Bulletin. Amateurs' Net Price \$139.50. MI-8303 Table Speaker in matched cabinet \$8.00 extra. All prices f. o. b. factory.

UNIFORM SENSITIVITY

Each r-f circuit has dual alignment with air-dielectric trimmers for high-frequency end and inductance adjustment of coils for low end.

BANDSPREAD TUNING

Calibrated bandspread for 10, 20, 40, and 80-meter bands extends to nearly full rotation of dial for "split-kilocycle" readings. Carrier level meter serves for both peak tuning and to measure signal strength in popular "S" scale.

6-STEP SELECTIVITY

Wide choice of selectivity assures operator control of signal interference.

IMPROVED IMAGE REJECTION

Image ratio of approximately 40-1 at 30 Mc is obtainable.

NEGATIVE FEEDBACK

Smooths out and extends the audio response curve.



for Performance Plus

RCA MANUFACTURING COMPANY, INC., Amateur Division, CAMDEN, N. J. • A Service of the Radio Corporation of America

NEW HIGHS in Tube Performance!



RCA-815 available
for delivery about
Dec. 1, 1940

TRANSMITTING TUBES

No.	Type	Max. Input	Amateur Net Price
801-A	Triode	42 Watts	\$ 3.45
802	Triode	33 Watts*	3.50
803	Pentode	350 Watts	28.50
804	Pentode	150 Watts*	15.00
805	Triode	315 Watts	13.50
806	Triode	1000 Watts*	22.00
807	Beam	75 Watts*	3.50
808	Triode	200 Watts	7.75
809	Triode	100 Watts*	2.50
810	Triode	620 Watts*	13.50
811	Triode	225 Watts*	3.50
812	Triode	225 Watts*	3.50
813	Beam	360 Watts	22.00
†815	Twin Beam	75 Watts*	4.50
825	Inductive Output Amp.	100 Watts	34.50
826	Beam	270 Watts*	17.50
834	UHF Triode	125 Watts	12.50
1623	Triode	75 Watts	2.50
1624	Beam	54 Watts	3.50

*ICAS rating. In CCS, tube is operated at somewhat lower ratings.

HALF-WAVE MERCURY-VAPOR RECTIFIERS

No.	Max. Ratings	Amateur Net Price
866	7,500 Volts, 0.25 a.	\$ 1.50
866-A	10,000 Volts, 0.25 a.	2.50
872	7,500 Volts, 1.25 a.	9.00
872-A	10,000 Volts, 1.25 a.	11.00

TELEVISION TUBES

No.	Description	Amateur Net Price
3AP4/906P4	3" Kinescope	\$13.75
5AP4/1805P4	5" Kinescope (Short Bulb)	22.00
5BP4/1802P4	5" Kinescope	22.00
1847	Amateur Iconoscope	24.50

CATHODE-RAY TUBES

No.	Screen	Amateur Net Price
3AP1/906P1	3" Green Phosphor	\$13.50
902	2" Green Phosphor	7.50
913	1" Green Phosphor	4.00

UHF ACORN TUBES

No.	Description	Amateur Net Price
954	Pentode Amplifier, Detector	\$5.00
955	Triode Detector, Oscillator	3.00
956	Pentode, Super-Control Amp.	5.00
957	Triode, 1.25-v., 0.05-a. Filament	3.00
958	Triode, 1.25-v., 0.1-a. Filament	3.00
959	Pentode, 1.25-v., 0.05-a. filament	5.00

RCA Tubes have always been noted for their big, extra measure of dependability. For years, however, amateurs have told us that RCA Ratings based on the most exacting commercial use were too conservative for intermittent amateur use. So now, two sets of ratings are given for popular amateur tube types—the old CCS (Continuous Commercial Service) and the new ICAS (Intermittent Commercial and Amateur Service) Ratings. You take your choice, based on your own individual requirements. You eliminate guesswork, and, as an amateur, you get higher power output at lower cost plus long tube life, plus the utmost in economy of weight and space.

PRACTICAL HELP . . . FREE!



Do you get your free copy of RCA Ham Tips, the helpful little publication for amateurs, by amateurs? If not, see your RCA Transmitting Tube Distributor.



Transmitting

RCA MANUFACTURING COMPANY, INC.,

NEW ADVENTURES

for the Radio Pioneer!

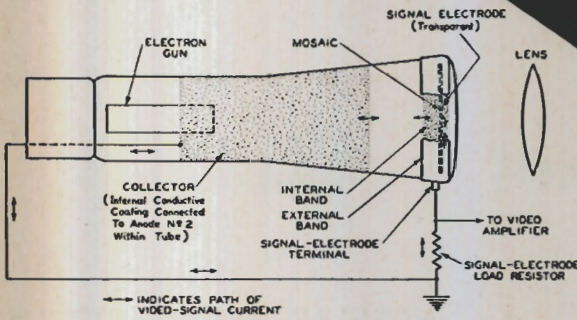

RCA-1847

AMATEUR ICONOSCOPE

"Mini-Ike" is the little brother of the big studio-type Iconoscopes. It is capable of producing clear pictures suitable for transmission in the 2½- or 1¼-meter bands, operates at relatively low voltage, employs inexpensive deflection circuits, and can utilize low-cost, short-focal-length lenses. *Amateur net* \$24.50

New fields to conquer—interesting new experiments to be tried—new thrills of achievement! That is the story of Amateur Television, the most fascinating development in amateur radio today!

An experimental amateur outfit produced under supervision of the same RCA engineers who have led the way in Television proves the practicality of good quality Amateur Television communication with simplified, economical apparatus that many a ham can build for himself. Even skeptics are frankly amazed at the faithful reproduction and stability of the pictures and with the simplicity of the complete equipment.

Based on a series of articles published in QST, this equipment utilizing the RCA 1847 "Mini-Ike" Iconoscope is described in detail in a booklet—free on request—or which may be obtained from your RCA Amateur Equipment Distributor. It tells you what to build and how to build it. And you'll be surprised to learn how much of your present equipment can be used—how little there is to buy.

RCA Ham Guide



The Booklet
no Amateur
will want to
miss

Just the booklet you've been waiting for! New circuits, new outfits, new diagrams for beginners as well as advanced amateurs. PLUS easy-to-use information on the complete line-up of RCA Transmitting Tubes for amateur needs. 48 pages. *Amateur net* 35c

Tubes

PROVED IN COMMUNICATION'S
MOST EXACTING APPLICATIONS

CAMDEN, N. J. • A Service of the Radio Corporation of America

Be Right with OHMITE

DUMMY ANTENNA RESISTOR

To Check R.F. Power and Tune Up



Check your R.F. Power and tune up to peak efficiency — determine transmission line losses—check line to antenna impedance match — all through the use of this new Ohmite Dummy Antenna. Non-inductive, non-capacitive, constant in resistance. Mounts in standard tube socket.

Model D-100, 100 watts, in popular 73 ohm and 600 ohm resistance values. Also in 13, 18, 34, 64, 100, 146, 219, 300, 400, 500 ohm values.

List Price \$5.50

Model D-250, 250 watts, in 73 ohm and 600 ohm values. **List Price** \$11

Send for Free Dummy Antenna Bulletin 111A

Patents Pending

PARASITIC SUPPRESSOR

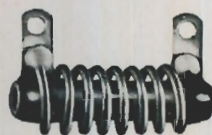

Ohmite P-300 Parasitic Suppressor—convenient, compact, efficient . . . designed to prevent ultra-high-frequency parasitic oscillations which occur in the plate and grid leads

of push-pull and parallel tube circuits. Non-inductive, vitreous-enameled resistor combined with a choke into one small integral unit. Only 1¼" long overall and ⅝" diameter.

List Price \$1.50

CENTER-TAPPED RESISTORS

Especially designed for use across tube filaments to provide an electrical center for the grid and plate returns. Center tap accurate to plus or minus 1%. Available in Wirewatt (1 watt) and Brown Devil (10 watt) units, in resistances from 10 to 200 ohms.

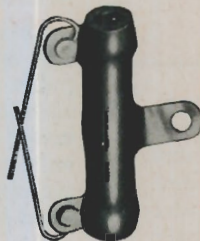

POPULAR BROWN DEVILS

There's good reason for the world-wide popularity of Ohmite "Brown Devil" Resistors. They're tough, extra-sturdy units—built right, sealed tight and permanently protected by Ohmite Vitreous Enamel. 10 and 20 watt sizes, in resistances from 1 to 100,000 ohms.

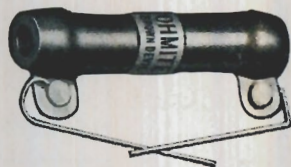

R. F. PLATE CHOKES

High frequency solenoid chokes designed to avoid either fundamental or harmonic resonance in the amateur bands. Single-layer wound on low power factor steatite cores with non-magnetic mounting brackets. Moisture-proof. Built to carry A THOUSAND MA. 4 stock sizes for 5 to 160 meter bands.



R. F. POWER LINE CHOKES

Just the thing to keep R. F. currents from going out over the power line, lessen interference with BCL receivers. Also to prevent high frequency and R. F. interference from coming in to the receiver. 3 stock sizes, rated at 5, 10, and 20 amperes. Consists of two chokes wound on a single core. Details in Bulletin 105.

SEND FOR YOUR FREE COPY OF NEW CATALOG 18

RHEOSTATS * RESISTORS * SWITCHES * CHOKES

* *Ohmite Vitreous Enamel is unexcelled as a protective and bonding covering for power rheostats and resistors.*

Vitreous-Enameled RHEOSTATS



These are the rheostats used by amateurs and broadcast stations alike to keep power tube filaments at rated value all the time—*increase tube life—get peak efficiency.* Time-proved Ohmite all-porcelain vitreous-enamelled construction and metal-graphite contact assure

permanently smooth, safe, exact control. Available in 25, 50, 75, 100, 150, 225, 300, 500, and 1,000 watt sizes, for all tubes and transmitters. (Underwriters' Laboratories Listed).

OHMITE BAND-SWITCH



A flick-of-the-wrist on the knob of this popular Ohmite Band-Change-Switch gives you instant, easy change from one frequency to another, with really low-loss efficiency. Band changing may be provided in all stages of the transmitter, and "ganged" for complete front-of-panel control. Can be used in rigs up to 1 K.W. rating.



FIXED RESISTORS

These are the same dependable Ohmite vitreous-enamelled resistors that are almost universally used by eminent designers and manufacturers of amateur and commercial transmitters and receivers. Available in 25, 50, 100, 160, and 200 watt stock sizes, in resistances from 5 to 250,000 ohms.

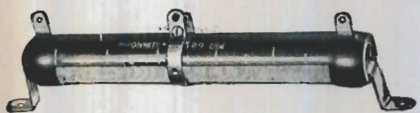

ADJUSTABLE DIVIDOHMS

Mighty handy resistors to have around when you need a change of resistor value or a replacement in a hurry. You can quickly adjust the Dividohms to the exact resistance you want and put on one or more taps wherever needed. Patented percentage of resistance scale. 7 ratings from 10 to 200 watts. Resistances up to 100,000 ohms.

Ask Your Jobber for the Ohmite parts you need, or Write today for Catalog 18.

All-Enclosed High-Current OHMITE TAP SWITCHES



Multi-point, load-break, non-shorting, single-pole, rotary selector switches particularly designed for alternating current use. Ideal for high current circuit switching in transmitter power supply and many heavy duty industrial applications. All-enclosed, ceramic construction. Extremely compact yet perfectly insulated. Self-cleaning, silver-to-silver contacts. "Slow-break," quick-make action. Shafts electrically "dead"—insulated with steatite. Available in single or tandem units; in 10, 15, 25, 50 and 100 ampere models, 1 3/4" diam. to 6" diam.

Send for Tap Switch Bulletin

Patents Pending

OHMITE

OHMITE MANUFACTURING CO.
4840 FLOURNOY STREET
CHICAGO, U.S.A. • *Cable "Ohmiteco"*

The Ideal Source of Plate Voltage
Where Commercial Electric
Power is not Available

Vibrapacks

(TRADE MARK REG. U. S. PAT. OFFICE)

Radio operators, engineers and public address men everywhere have discovered that the most satisfactory and economical answer to dependable plate voltage from a storage battery source is a Mallory Vibrapack. This *perfected* Vibrator type power supply is easy to use . . . efficient and gives long service.

THE COMPLETE VIBRAPACK LINE

Catalog Number	Nominal Operating Voltage	Nominal Output Voltage	Maximum Output Current	Type	Price
VP-551	6.3	125-150-175-200	100 ma.	Self-Rectifying	\$15.00
VP-552	6.3	225-250-275-300	100 ma.	Self-Rectifying	18.50
VP-553	6.3	125-150-175-200	100 ma.	Tube-Rectifier	16.50
VP-554	6.3	225-250-275-300	100 ma.	Tube-Rectifier	20.00
VP-555*	6.3	300	200 ma.	Tube-Rectifier	37.50
VP-557*	6.3	400	150 ma.	Tube-Rectifier	37.50
VP-G556	12.6	225-250-275-300	100 ma.	Self-Rectifying	20.00
VP-F558	32.	225-250-275-300	100 ma.	Tube-Rectifier	20.00

* Special Dual Packs for high output.

Mallory Vibrapacks are available in both self-rectifying and tube-rectifying types. The complete line includes single and dual Vibrapacks for outputs up to 60 watts. Type VP-G556 is designed for operation with the 12 volt batteries commonly used in airplane, bus and boat service. Free engineering service in adapting the Vibrapack to your requirements is available on request.



Send for Technical Data

An 8-page booklet containing complete descriptions of all Mallory Vibrapacks with application suggestions, technical data and instructions, is available upon request.

Ask for Vibrapack Booklet — Form E-555-C

P. R. MALLORY & CO. Inc. MALLORY Transmitting Capacitors

It's worth a good bit to be confident of the reliability of your transmitter—to know that when you close the "big switch," your rig is ready to deliver a 19X signal. It's false economy to use "bargain" filter condensers since their failure can result in damage to expensive transmitter components. For certain condenser satisfaction be sure to use Mallory Transmitting Condensers.

Mallory type TZ Transmitting Condensers are compact economy units for those who must watch their costs. These round aluminum container units have all the essentials, and are built with true Mallory quality. Available in sizes to 1500 working volts DC.

If you prefer square containers then Mallory TX transmitting condensers will fill your requirements. Available in 21 stock sizes, with working voltages from 600 volts to 6000 volts, these condensers have every needed feature—and a safety factor that insures long life even under adverse conditions. Constructed with an exclusive dielectric that gives longer life and greater dependability . . . Mallory Transmitting Capacitors are a real safeguard for expensive rigs. This Mallory developed dielectric provides high dielectric constant, high voltage breakdown and high, stable insulation resistance, with low power factor under all operating conditions.



P. R. MALLORY & CO. Inc. MALLORY Grid Bias Cells



Minimum distortion, less hum and lower cost can be obtained with Mallory Grid Bias Cells. Write for Form B-303 which gives complete engineering data.

Use

P. R. MALLORY & CO. Inc.
MALLORY
APPROVED
PRECISION PRODUCTS

P. R. MALLORY & CO., Inc.

FOR THE FINEST IN SWITCHES . . . IT'S **MALLORY!**

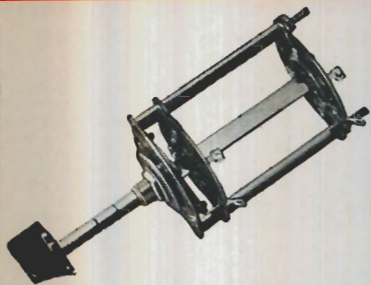

"Hamswitch"

Designed for economy and convenience, this Mallory-Yaxley Hamswitch No. 151L permits the use of a single meter to measure currents or voltages on up to and including five circuits in an amateur transmitter. An adjustable stop permits easy adaptation for fewer positions.



Multiple Push Button

Mallory-Yaxley Type 2190 switches make it possible to measure a number of circuits with a single current reading meter. The insertion of the meter in the circuit is accomplished merely by pushing a button. Other circuits connected to the switch remain closed and uninterrupted.



"HamBand"

Mallory-Yaxley HamBand Switches make transmitter wave band switching as convenient as changing bands on your communications receiver. Convenient terminal arrangement, wide spacing of current carrying parts, heavily silverplated contacts and low-loss magnesium silicate ceramic insulation are features especially designed for high-frequency applications. Your distributor has data sheets.

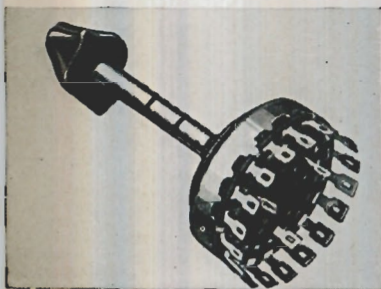

SINGLE GANG CIRCUIT SELECTOR

Positive action and long life are two outstanding characteristics of this switch . . . just one of many types available.

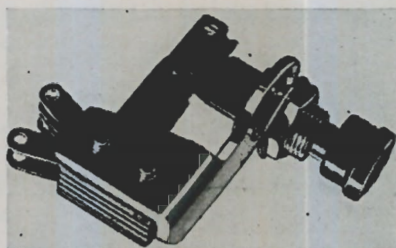

SINGLE PUSH BUTTON

Yaxley Push Button switches are ideal for meter shunt service, as well as for set analyzers, tube checkers and other test equipment. Available in both locking and non-locking types with a variety of spring contact arrangements.

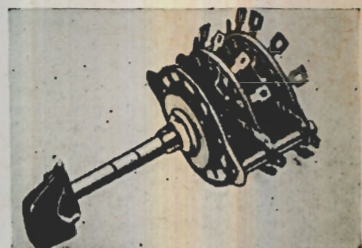

MULTI-GANG CIRCUIT SELECTOR

Here's the ideal answer to simplified control of complicated circuits. Positive action and long life are assured by rigid construction.

FOR THE BEST IN RADIO HARDWARE . . . IT'S **MALLORY!**

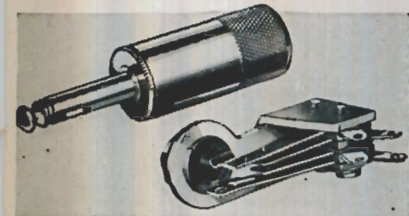

Yaxley Two-way phone plug No. 75N, with shielded nickel shell. Other types—three-way, tie cord, etc.—in both bakelite and nickel shells.

Yaxley Junior Jack No. 704—springs are parallel to panel for compactness—thirteen combinations available.



Avoid run down batteries, or increased power bills by using Mallory-Yaxley Pilot Lights and Jewels as indicators. They will keep you "informed" at all times, and enhance the appearance of your rig. These real money savers are available in red, green and white.



This three circuit microphone jack No. 2B is typical of the famous Mallory-Yaxley Line. A variety of spring combinations is available for practically any application and special models can be furnished on order.

You should be familiar with all the products manufactured by Mallory-Yaxley. They include condensers, phone plugs, tip jacks and plugs, jacks and jack switches, resistors, dial lights as well as many other items. Send for a complete catalog today.

SEND FOR COMPLETE CATALOG

INDIANAPOLIS . . . INDIANA
CABLE ADDRESS—PELMALLO

Use

P. R. MALLORY & CO. INC.

MALLORY
APPROVED
PRECISION PRODUCTS

TUBULAR ANTENNAS AND ELEMENTS

Premax Monel Antennas are designed for marine and other commercial uses where high strength, unusual resistance to corrosion and ability to withstand the most severe wind and shock strains are essential. They are built up of multiple sections of hard-drawn Monel tubing, fully telescoping and adjustable. Firm, rigid contact is secured between sections by precisely designed clutch-type clamps.

Premax Aluminum Antennas combine light weight, corrosion resistance and adequate strength to meet the most exacting requirements. Sections are of special drawn bright finish seamless aluminum engineered to stand wind velocities up to 60 m.p.h. Recommended for mobile installations, fresh water craft, police, fire, forestry or for home receiving antennas.

Premax Steel Antennas, heavily plated in bright cadmium, are highly resistant to corrosion and extremely strong. Used for vertical radiators, home receivers, and commercial installations.

Premax Corulite Elements, a ribbed style preferred for horizontal mounting because of great strength, lightness and rigidity. Tubular units (illustrated at bottom of page) that are fully telescoping and adjustable.

BASE INSULATORS

TYPE 1



Lapp design heavy-duty footing or base insulator for Premax vertical antennas. Heavy, wet-process, brown-glaze porcelain cones held in compression between hot-galvanized malleable iron castings which form the base support.

Tested compression rating up to 10,000 lbs. and will support 35' vertical under ordinary wind stresses without use of guys or other supports. Height to top 7"; bolt circle 5 1/4"; weight 7 lbs. Complete with mounting bolts and nuts.

MONEL ANTENNAS — LESS INSULATOR

No.	Sec.	Ext'd Length	Col. Lth.	Base O. D.	Top O. D.	Base I. D.	Weight Each	Price Each
MM-213	2	13'1"	6'9"	.625"	.489"	.555"	2 1/2 lbs.	\$25.50
MM-119	3	19'1 1/2"	6'9"	.750"	.489"	.666"	5 lbs.	36.00
MM-225	4	24'10 1/2"	6'9"	.875"	.489"	.777"	8 lbs.	48.00
MM-330	5	30'0"	6'9"	1.063"	.489"	.935"	13 lbs.	63.00
MM-335	5	35'0 1/2"	7'8"	1.063"	.489"	.935"	15 lbs.	69.00

Number	Old Number	Diameter Top Post	Price Each
1P-24	136-L	3/4"	\$9.00
1P-26	New	3/4"	9.00
1P-30	New	3/4"	9.00
1P-44	136-P	1 1/8"	9.00

ALUMINUM ANTENNAS — LESS INSULATOR

No.	Sec.	Ext'd Length	Col. Lth.	Base O. D.	Top O. D.	Base I. D.	Weight Each	Price Each
AM-312	2	12'2 1/2"	6'3"	.500"	.320"	.334"	1 1/2 lbs.	\$ 4.50
AM-518	3	18'0 1/2"	6'3"	.750"	.320"	.584"	3 lbs.	8.25
AM-124	4	23'8 1/2"	6'3"	1.000"	.320"	.810"	5 lbs.	12.75
AM-230	5	29'2"	6'3"	1.312"	.320"	1.112"	7 1/2 lbs.	18.75
AM-336	6	34'8"	6'3"	1.625"	.320"	1.425"	11 lbs.	27.00



TYPE 2

A light design base insulator suitable for vertical antennas up to 18' height or with greater lengths if properly guyed or supported with stand-off mountings. Of brown glaze porcelain with top post and base support cemented in insulator. Metal parts galvanized. Porcelain diameter 3 1/4"; height to top of porcelain 6"; flange diameter 3 1/4"; weight 4 lbs. Furnished complete with the necessary mounting bolts and nuts.

STEEL ANTENNAS — LESS INSULATOR

No.	Sec.	Ext'd Length	Col. Lth.	Base O. D.	Top O. D.	Base I. D.	Weight Each	Price Each
112-M	2	11'8"	6'1"	.656"	.500"	.556"	4 lbs.	\$3.00
318-M	3	17'3"	6'2"	.875"	.500"	.775"	7 lbs.	4.50
224-M	4	22'9"	6'3"	1.063"	.500"	.963"	11 lbs.	6.00
130-M	5	28'3"	6'4"	1.250"	.500"	1.150"	15 lbs.	7.50
136-M	6	33'9"	6'5"	1.500"	.500"	1.400"	20 lbs.	9.00

No.	Old No.	Dia. Top Post	Price Each
2P-24	318-P	3/4"	\$3.00

CORULITE ELEMENTS

No.	Sec.	Ext. Lth.	Col. Lth.	Base O. D.	Top O. D.	Weight Per Pair	Price Per Pr.
104-M	1	4'0"	4'0"	3/8"	3/8"	1 lb.	\$1.50
108-M	2	8'2"	4'7"	3/8"	3/8"	2 lbs.	3.30
113-M	3	12'4"	4'8"	1/2"	3/8"	3 1/2 lbs.	5.40
618-M	4	17'0"	5'3"	1"	3/8"	5 1/2 lbs.	7.50

Premax Corulite Elements are sold only in pairs, as listed.

TYPE 6

Type 6 Base Insulator will be recognized as the most practical unit available for mounting vertical antennas on shipboard, or on rooftops, tower platforms, mobile trucks, etc. In general construction it is similar to Type 1 with the same general characteristics. Simple to install, neat in appearance. The lead-through design avoids necessity for extra holes, lead-in bushings, etc. Flanges 6" diameter with 6 bolt holes on 5" circle. Center stud suited for decks 1/2" to 3" thick. Total height above deck 4 1/4". Weight 11 1/4 lbs. Available in hot-galvanized or solid bronze with exposed bronze portions polished.



SPECIFICATIONS — RODS ONLY, LESS MOUNTING

Lth.	CADMIUM		STAINLESS	
	No.	Price	No.	Price
72"	AC-172	\$1.50	AS-172	\$3.30
78"	AC-178	1.65	AS-178	3.60
84"	AC-184	1.80	AS-184	3.90
90"	AC-190	1.95	AS-190	4.20
96"	AC-196	2.10	AS-196	4.50

No.	Diameter Top Post	Price Each	
		Galv.	Bronze
6P-24	3/4"	\$12.75	\$22.50
6P-26	3/4"	12.75	22.50
6P-30	3/4"	12.75	22.50
6P-44	1 1/8"	12.75	22.50

PREMAX CORULITE TYPE STEEL ELEMENTS

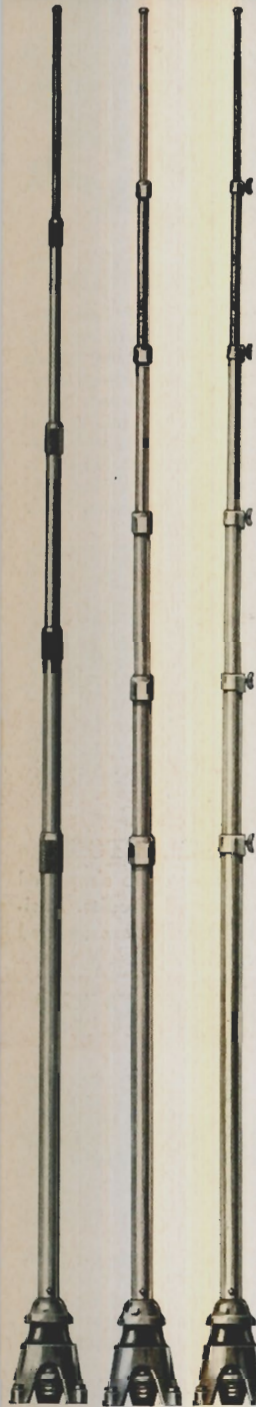

STYLE MM MONEL STYLE AM ALUMINUM STYLE M STEEL STYLE A POLICE

UNIT 618-M

UNIT 113-M

UNIT 108-M

UNIT 104-M

Ask your jobber for the new Premax Antenna

Bulletin No. 29 giving complete details of Antennas, Mountings, Insulators and Accessories. If he cannot supply you, write direct.

Learn Code the Easy Way

This automatic code transmitter, the Instructograph, with its Book of Instruction, affords one of the quickest, easiest and most practical methods of teaching the code that has yet been devised.

The Instructograph is a scientifically constructed machine that sends telegraphic characters perfectly at any desired speed. By so doing it literally takes the place of an operator-instructor, and enables anyone to learn either the Morse or Continental codes without any further assistance.

MACHINES FOR RENT OR SALE

The "Standard" Instructograph

The "Standard" as illustrated is strongly constructed, enclosed in an attractive case and is built for years of usefulness. Ten code tapes and the instruction book are supplied with the machine. Can be furnished either with an electric 110-volt 60-cycle AC motor or a spring wound motor. Priced \$24.50 for the electric motor and \$18.50 for the spring wound motor. These prices are delivered to any point in the United States or Possessions, \$1.00 additional to points in Foreign Countries. May be purchased on convenient monthly payments if desired.

The "Junior"

The "Junior" operates just as efficiently as the larger machine and also comes in an attractive case. The difference being mainly in size and construction. Five tapes and the book of instructions are supplied with this machine. Priced \$12.00 delivered to any point in the United States or Possessions, and \$13.00 to points in Foreign Countries. Sold on easy monthly payments if desired.



With these machines it is necessary to use an oscillator or buzzer to furnish the beat note. Full oscillator equipment with audio transformer and tube socket designed to fit inside the machine. Priced \$5.50 (less battery). When bought with an Instructograph this is wired and installed in the machine.

RENTAL PROPOSITION

The "Standard" machine only is used in Rental Service and rentals apply only to the United States proper.

Instructograph, 10 tapes and book of instructions; For the 110 volt 60 cycle AC motor; First month \$3.50, each additional month \$2.75. For the spring wound motor; First month \$3.00, each additional month \$2.25.

For audio transformer and tube socket installed add 25c per month. For full oscillator equipment add 50c per month. (Tube and battery not rented but may be purchased for \$1.00.)

We pay return transportation charges on all rentals. A deposit of \$10.00 in addition to the rental or satisfactory references and sufficient information about yourself is required.

All rental payments may be applied on the purchase price should you decide to buy the equipment.

The Instructograph Accomplishes These Purposes:

- FIRST: — It teaches you to receive telegraph symbols, words and messages.
- SECOND: — It teaches you to send perfectly.
- THIRD: — It increases your speed of sending and receiving after you have learned the code.

With the Instructograph it is not necessary to impose on your friends. It is always ready and waiting for you. You are also free from Q.R.M. experienced in listening through your receiver. The speed range is five to forty words per minute and the tapes range from the alphabet to typical messages on all subjects including code group tapes that cannot be memorized. This machine is just as valuable to the licensed amateur for increasing his speed as to the beginner who wishes to obtain his amateur license.

POSTAL CARD WILL BRING FULL PARTICULARS
IMMEDIATELY

THE INSTRUCTOGRAPH CO.

4701 SHERIDAN ROAD

(Dept. H. B. 7)

CHICAGO, ILLINOIS



PYRANOL CAPACITORS

Cost Less because They Last Longer

PYRANOL is a non-inflammable, non-explosive dielectric developed and patented by General Electric. Its extraordinary insulating and dielectric properties make possible the unusual compactness of G-E capacitors. Thousands of them are in service all over the world. Quality-controlled materials, carefully supervised manufacture, and years of tested application experience all combine to give hams an unexcelled product.

Hermetical sealing assures permanence of the characteristics of Pyranol capacitors; contamination from air and moisture is impossible. G-E Pyranol capacitors are noted for their long life. Write for bulletin GEA-2021B.



RATINGS AND PRICES

Cylindrical Cases

Volts D-C	Mfd	Catalog No.	Net Price*
600	2	23F60	\$1.95
	3	23F61	2.25
	4	23F62	2.70
1000	1	23F63	1.65
	2	23F64	2.25
	3	23F65	2.55
	4	23F66	2.85
1500	0.5	23F67	1.80
	1.0	23F68	2.10
	2.0	23F69	2.85
2000	1.0	23F70	2.70
	2.0	23F71	3.00

LOW CAPACITY, SMALL SIZE UNITS

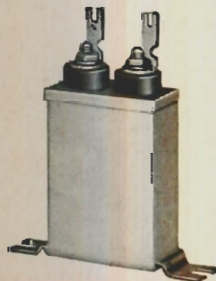

Volts D-C	Mfd	Catalog No.	Net Price*
500	1.0	23F54	\$1.80
1000	0.01	23F55	1.20
1000	0.05	23F56	1.35
1000	0.1	23F57	1.50
1000	0.25	23F58	1.65
1000	0.5	23F59	1.80

RATINGS AND PRICES

Rectangular Cases

Volts D-C	Mfd	Base Mounting		Inverted Mounting	
		Cat. No.	Net Price*	Cat. No.	Net Price*
600	1	23F1	\$2.10	26F172	\$2.10
	2	23F2	2.55	26F167	2.55
	4	23F4	3.30	26F106	3.30
1000	1	23F10	2.25	26F156	2.25
	2	23F11	3.00	26F157	3.00
	4	23F13	3.75	26F93	3.75
	5	23F14	4.50	26F176	4.50
1500	1	23F20	2.70	26F181	2.70
	2	23F21	3.75	26F182	3.75
	4	23F23	5.10	26F184	5.10
	5	23F24	5.40	26F185	5.40
	2000	1	23F30	3.30	26F190
2500	2	23F31	3.90	26F191	3.90
	4	23F33	5.40	26F193	5.40
	5	23F34	6.00	26F194	6.00
	1	23F39	4.80	26F199	4.80
3000	2	23F40	7.80	26F200	7.80
	4	23F41	10.80	26F201	10.80
	1	23F42	7.20	26F202	7.20
4000	2	23F43	9.00	26F203	9.00
	4	23F44	13.20	26F204	13.20
	0.5	23F45	10.80	26F205	10.80
5000	1	23F46	13.20	26F206	13.20
	2	23F47	16.80	26F207	16.80
	0.5	23F48	19.20	26F208	19.20
	1	23F49	15.00	26F209	15.00
	2	23F50	19.20	26F210	19.20

* Represents 40% off list price.

**COMPACT DEPENDABLE UPRIGHT OR INVERTED MOUNTING
CONTINUOUS OPERATION AT 10% OVERLOAD FIREPROOF**



TRANSMITTING TUBES

Priced Low . . . Unsurpassed in Value

GENERAL ELECTRIC has designed and built tubes to meet the most exacting requirements on land and sea and in the air for more than 27 years. G.E. on a transmitting tube assures you of long, dependable service

at low cost. Bulletin GEA-3315 lists the complete G-E transmitting-tube line, together with technical data and prices. Ask your dealer for a copy or write to General Electric, Schenectady, N. Y.

G-E BEAM POWER TUBES

for More Power with Less Equipment
Low Driving Power
Quick Band Change

GL-807 NET \$3.50

The G-E beam tube for your low-power requirements. Oscillator, amplifier, frequency multiplier or modulator—you can't buy a more versatile performer for \$3.50! Less than half a watt drives two 807's; ICAS cw output: 100 watts!

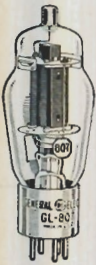

GL-814 NET \$17.50

The G-E beam power tube for any medium-power r-f application up to 30 mc. 160 watt cw. 130 watts plate-modulated phone (ICAS) with 1.5 or 3.2 watts driving power respectively. A fb frequency multiplier, too. \$17.50 puts one in your rig.



GL-813 NET \$22.00

The G-E beam tube for high power. It will produce 150 watts cw as a crystal oscillator, 260 watts cw with only 0.5 watt driving power. An excellent frequency multiplier. Makes quick band change at high power easy.

FOR ECONOMICAL MEDIUM POWER

GL-811 . . . High Mu Triode
ICAS* Class B Modulator Rating (2 tubes)
Max. Plate Volts 1500
Max. Plate Current 200 mls
Driving Power 10.5 watts
Output Power 225 watts

NET \$3.50

GL-812 Low Mu Triode
ICAS* Class C Telegraph Rating
Max. Plate Volts 1500
Max. Plate Current 150 mls
Driving Power 6.5 watts
Power Output 170 watts
Max. Frequency 100 mc.

NET \$3.50

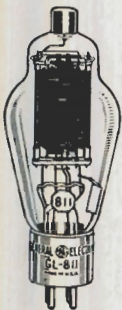

*Intermittent Commercial and Amateur Service

G-E MERCURY-VAPOR RECTIFIERS

GL-866 NET \$1.50

Max. Peak Inverse Volts 7500
Peak Plate Current 1 amp
Average Plate Current 0.25 amp

GL-866A NET \$2.50

Max. Peak Inverse Volts 10,000
Peak Plate Current 1 amp
Average Plate Current 0.25 amp



FOR HEAVY DUTY

GL-872 NET \$9.00

Max. Peak Inverse Volts 7500
Peak Plate Current 5 amp
Average Plate Current 1.25 amp

GL-872A NET \$11.00

Max. Peak Inverse Volts . . 10,000
Peak Plate Current 5 amp
Average Plate Current . . 1.25 amp



TOPS IN "50-WATTERS"

GL-838

Class B Audio 260 watts output (2 tubes)

Class C Telephony 100 watts output

Class C Telegraph 130 watts output

Max. Frequency 30 mc at full input; 120 mc at reduced ratings

NET \$11.00



NET PRICES

GL-203A . . .	\$10.00
GL-211	10.00
GL-800	10.00
GL-801	3.45
GL-802	3.50
GL-803	28.50
GL-805	13.50
GL-806	22.00
GL-807	3.50
GL-809	2.50
GL-810	13.50
GL-811	3.50
GL-812	3.50
GL-813	22.00
GL-814	17.50
GL-833	85.00
GL-837	7.50
GL-838	11.00
GL-845	10.00
GL-860	32.50
GL-866	1.50
GL-866A . . .	2.50
GL-872	9.00
GL-872A . . .	11.00
GL-1623 . . .	2.50

U. S. GOVERNMENT
AIRLINES
MANUFACTURERS
BROADCASTERS

rely on **JOHNSON**

- **Antennas**
- **Insulators**
- **Condensers**
- **Inductors**
- **Tube Sockets**
- **Plugs & Jacks**

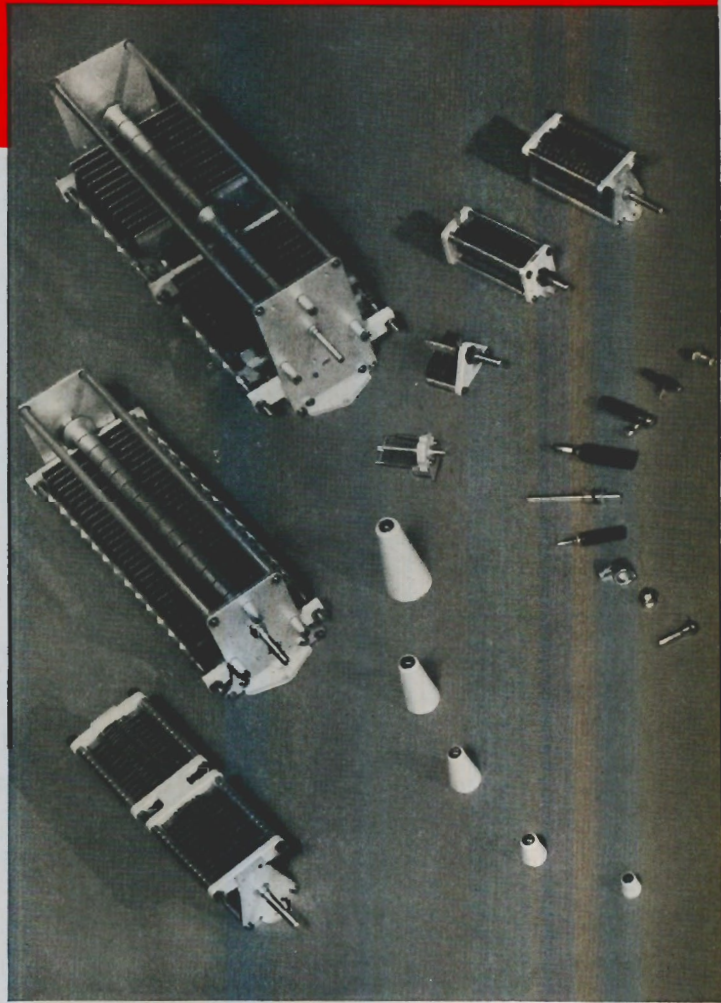

Famous Johnson products are being used by every big name manufacturer of diathermy and radio transmitting equipment. These same identical parts are available to you from your jobber. We could not crowd even a representative showing of the line into the above photograph but your jobber has a catalog for you including the Johnson-Bassett antenna and concentric feeder line. Don't use cheap inferior products when the best cost no more. Compare Johnson prices and you will be agreeably surprised. The answer? — quantity production.

it's also YOUR guarantee of dependability



Ask for
CATALOG 966M

Consult your PARTS JOBBER
He values your business and will advise you on your problems. He employs amateurs to serve you—make use of their experience. And remember — all better Jobbers can supply Johnson and Johnson-Bassett products.



E. F. JOHNSON CO

WASECA, MINNESOTA

EXPORT: 25 WARREN ST., NEW YORK, N. Y.

MANUFACTURERS OF RADIO TRANSMITTING EQUIPMENT

KENYON

QUALITY TRANSFORMERS

Behind the doors of some of America's finest radio transmitting equipment, Kenyon Transformers carry on — doing their work quietly, efficiently, dependably even under the most adverse conditions. Such a record of performance is truly a model for the entire industry.

**Kenyon
Portable Broadcast Units**

These excellent units are small yet extremely efficient. For both field and station operation.

**Laboratory
Standard Units**

"The Standard of the World." Used by the most discriminating for faithful reproduction.

Modulation Transformers

We manufacture all types up to and including the 10 K.W. units for commercial service.

Special Units

A large portion of the business done by Kenyon is on special units to fulfill special applications. Small or large quantities.

Audio Transformers

- Shielded, Humbucking types
- Lab. Standard units, uniform from 20 to 20,000 cycles
- Plug in types for governmental, aircraft and other applications where space is at a premium.

Filament Transformers

Every conceivable type from the smallest to the great high reactance type for 50 KW final.

Plate Transformers

From the 75 volt bias type to the huge 3 phase air and oil cooled units for large plants, broadcast stations, etc.

Amateur Transformers

Long a favorite with amateurs everywhere. On this page we list but a few of the many types we manufacture. Complete catalog FREE on request.

UNIVERSAL MODULATION TRANSFORMERS

Type No.	Audio Output Primary	Net Price
T-489	15 watts	\$2.70
T-493	40 watts	3.90
T-494	75 watts	5.85
T-495	125 watts	13.20
T-496	300 watts	19.80

PLATE TRANSFORMERS

Type No.	D.C. Volts	D.C.M.A.	Net Price
T-668	500/750	300	\$5.85
T-669	1000/1250	300	9.60
T-670	1500/1750/2000	300	12.90
T-671	1000/1250	500	12.90
T-672	1000/1250/1500	300	11.85

FILAMENT TRANSFORMERS

Type No.			Net Price
T-388	2.5, 5, 6.3 V — 3A	1000 V. Test	\$1.65
T-352	2.5 V. — 10 A. CT.	2000 V. Test	2.10
T-360	2.5 V. — 10 A. CT.	5000 V. Test	3.00
T-389	2.5 V. — 10 A. CT.	9000 V. Test	4.50
T-390	5 V. — 20 A. CT.	10000 V. Test	8.40
T-391	5 V. — 20 A. CT.	5000 V. Test	4.80
T-387	6.3, 6.45, 6.6 V. — 8A	2000 V. Test	2.40

FILTER REACTORS

Type No.	Inductance Henries	Max. M.A.	Net Price
T-153	30	90	\$1.95
T-152	10	200	2.40
T-166	11	300	4.65

SWINGING REACTORS

Type No.	Inductance Henries	Max. M.A.	Net Price
T-517	15-45	90-20	\$1.95
T-506	5-20	200-30	2.40
T-510	6-19	300-30	4.65

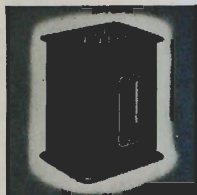

The one style, universal mounting case design of Kenyon Transformers adds eye appeal and beauty to the finished product.

Send for FREE CATALOG showing hundreds of types not listed above



KENYON TRANSFORMER CO., Inc.

840 BARRY STREET

NEW YORK, N. Y.

OFFICES IN PRINCIPAL CITIES

Cleveland	3292 Cedarbrook Rd.	Seattle	2605 Second Ave.	New Orleans	618 Girod St.
Chicago	21 E. Van Buren St.	Los Angeles	2412 7th St., W.	Lutz	Florida
Kansas City, Mo.	2094 Grand Ave.	Dallas	P. O. Box 4116, Sta. A	Richmond, Va.	3106 Edgewood Ave.

STOP GUESSING!

SPRAGUE

PLAY SAFE!

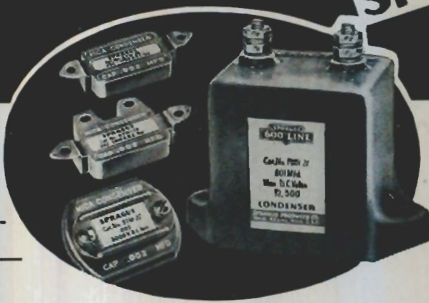

All Sizes—
All Shapes—
All Voltages—

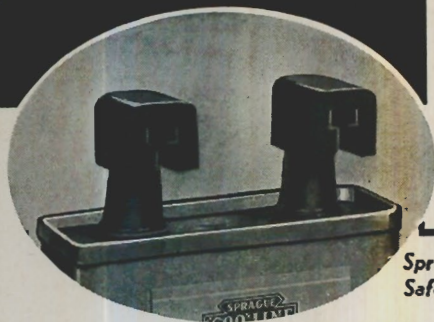

Sprague Lifeguard
Safety Caps FREE

NEW SPRAGUE HIGH VOLTAGE MICAS

You don't have to go looking with a microscope for voltage markings on Sprague High Voltage Mica Condensers! Each voltage has a different colored label for quick and positive identification — red for 5,000 volt condensers, blue for 2,500 volt and green for 1,000 volts. Condensers are molded in moisture-proof, low-loss bakelite, while the extremely high voltage units are sealed in non-hygroscopic porcelain.

You're sure the voltage is right. You know from past experience that Sprague quality cannot be surpassed

Lifeguard Safety Caps for exposed condenser terminals are only one of four outstanding safety features that make Sprague Transmitting Condensers (round or rectangular types) tops for any amateur need. Terminals are perfectly insulated from the cans; cans are automatically grounded through the mounting clamps; and all condensers are oil-impregnated and oil-filled (not wax-filled) with SPRACOL, the 500° flash protection oil.

Lifeguards are supplied free with every Sprague Transmitting Condenser — or you can buy them for your old condensers at 15¢ per pair, amateur net.

SAVE MONEY! . . . with Type UC Transmitting Condensers

For either beginners or old timers who don't want to invest much money in a rig, we heartily recommend Sprague Type UC cardboard type "uncased" paper sections. They'll do a tip-top job on requirements up to 1,000 volts at about one-third the price of standard high voltage units. You can buy a UC-14 1 mfd. 400 volt condenser for only 45¢ amateur net; a UC-18 1 mfd. 800 volt for only 75¢; or a UC-11 1 mfd. 1,000 volt for only 90¢ net. Other capacities proportionately low. It should pay you to investigate!



TRY TELEVISION!

Along with a lot of other amateurs, you'll probably soon be giving Television a whirl — and when you do, look to Sprague for the right condensers. For several year past, we have been working with leading equipment manufacturers and have developed a complete line of quality units specifically constructed for exacting Television requirements. See page 20 of the new Sprague Condenser Catalog for standard types now generally available.



LOOK AT THESE RESISTOR VALUES!

Study the construction of Sprague Koolohm Resistors. See for yourself the tremendous plus-values you get every time you use one. Common sense will tell you the advantage of having every bit of wire insulated *before it is wound* with a special heat-proof, moisture-resistant material. Layer windings, larger wire sizes, more resistance in less space, 5% accuracy, no chance for shorted windings, cooler operation, inexpensive non-inductive windings . . . these are but a few of the resulting features that are unsurpassed in the resistor market today. Write for Koolohm Catalog.



SPRAGUE KOOLOHM RESISTORS



Cross Section — showing progressive inter-leaved windings for higher resistance values in less space.

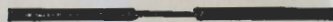

Cross Section — showing wire used in Koolohms with a section of the insulation removed

AVOID FAILURES!

Other condenser types come and go, but famous Sprague TC Tubulars go on forever. The reason? Well, it's simply that you can't beat them for any by-passing requirement. Test voltage 1200, working voltage 600. Made in a complete line.



"Not a Failure in a Million"

GET THIS CATALOG FREE!

The biggest most complete Condenser Catalog Sprague has ever issued. Ask your jobber or write to us. Ask for the 1941 Catalog.

SPRAGUE PRODUCTS CO.

North Adams, Mass.

SPRAGUE

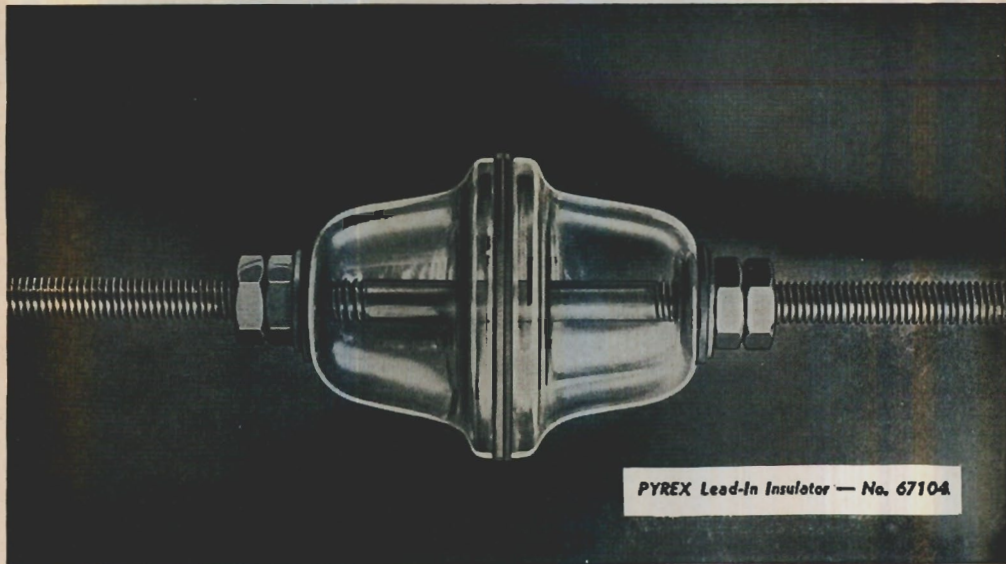

PYREX Lead-In Insulator — No. 67104

Clearer reception! Greater range with
PYREX BRAND GLASS INSULATORS



ABOVE: PYREX Antenna Insulators —
Nos. 67021, 67017, 67007.

BELOW: PYREX Stand-Off Insulators for High Power
Transmitters — Nos. 67107, 67109.

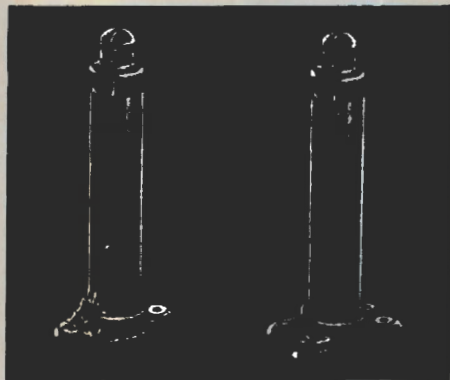

THERE'S no doubt about it! Pyrex Radio Insulators, made from tough, non-porous PYREX brand glass, bring in clearer signals from greater distances under any weather conditions!

Formed in a single piece, with a smooth surface that can't absorb moisture, PYREX Insulators have no pores or cracks for dust to lodge in. There is no glaze to chip or crack.

The result is an insulator of great stability with superior surface resistance and minimum power loss . . . the very features you've been looking for!

Send now for the free folder or United catalog pages describing the complete line of PYREX Radio Insulators. Specify PYREX Insulators next time you buy from your local radio supply house.

CORNING MEANS
RESEARCH IN GLASS

CORNING GLASS WORKS
CORNING, N. Y.

ASTATIC PRODUCTS

MODERNIZE YOUR EQUIPMENT

ASTATIC LOW PRESSURE PICKUPS

Models FP-18 and FP-38 Low Pressure Pickups are a great stride forward in the perfecting of phonograph reproduction. Low stylus pressure, long record life, no needles to change and improved performance are outstanding features. Built-in, permanent sapphire stylus will last indefinitely. One ounce, featherweight, stylus pressure on record reduces wear, surface noise and distortion. Lustrous, deep maroon plastic finish. Complete with shielded cable and arm rest.

MODEL FP-18
(Frequency Response
30 to 7,000 cycles)

MODEL FP-38
(Frequency Response
30 to 10,000 cycles)

List Price
Each \$16.50

Illustration below shows Astatic's
new Low Pressure Crystal Pickup.



MODEL UT-48 CRYSTAL MICROPHONE

Because it so completely meets the ever increasing demand for a moderate priced, speech-range microphone, Model UT-48 is known as Astatic's "Amateur Special." Tilting head permits semi- or non-directional positions. High output level, -48db. Frequency response designed with rising characteristics above 500 cycles. Modern die-cast grille and body. Satin chrome finish. Complete with swivel mount, concentric cable connector and 7-ft. cable.

Voice-Range
MODEL UT-48

List Price
\$16.50

ASTATIC

ASTATIC MICROPHONE
LABORATORY, INC.
Youngstown, Ohio

In Canada: Canadian Astatic, Ltd.,
Toronto, Ontario

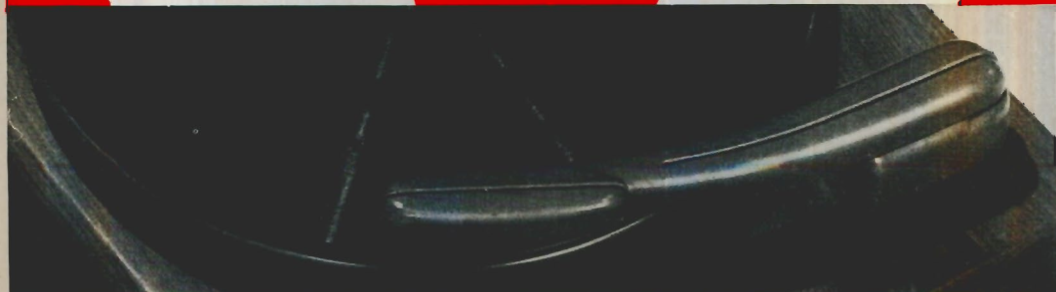

Astatic Crystal Products Licensed Under Brush Development Co. Patents

Centralab

CRL

The Quality Line

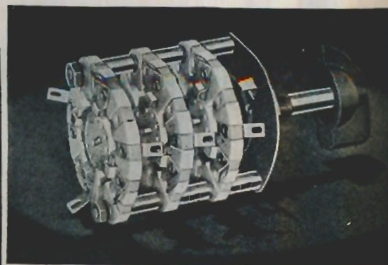

SELECTOR SWITCH

Available in an almost infinite variety of combinations . . . in bakelite or isolantite . . . in single or multiple gang . . . from two to eleven positions on any one switch . . . also available for use in amateur transmitters.

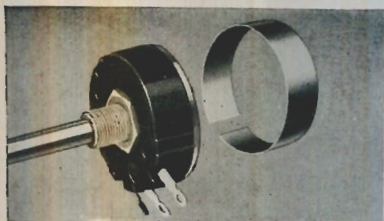

STANDARD RADIOHM

Featuring maximum resistor length to case diameter . . . accurate tapers . . . low noise level . . . longer life . . . better power dissipation and better all 'round performance.

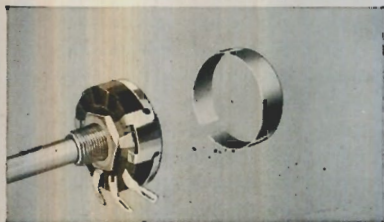

MIDGET RADIOHM

In compact sets space is at a premium; the MIDGET fills the bill . . . bakelite case $1\frac{1}{8}$ " diameter . . . $\frac{1}{4}$ " aluminum shaft . . . $3\frac{3}{8}$ " long milled for standard push-on or get-screw knob.

ATTACHABLE SWITCH COVERS

For standard and wire wound resistors (Radiohms) as well as Midget Radiohms . . . S.P.S.T. . . . S.P.D.T. . . . D.P.S.T. . . . four point . . . S.P.D.T. (operates at clockwise position) and S.P.S.T. with Dummy Lug.



Hams, Servicemen, Experimenters and Manufacturers appreciate the utter dependability of Centralab products. Since 1922 more than a hundred million radio parts bespeak the universal acceptance accorded Centralab products. Send for catalog if your jobber cannot supply you.

CENTRALAB
Div. of Globe-Union Inc.
MILWAUKEE



SPLIT-KNURL REPLACEMENTS

Can be easily adapted to many of the current sets by merely cutting shaft to proper length . . . of brass . . . easy to cut . . . extends 3" from the end of a $\frac{3}{8}$ " bushing.

WIRE WOUND RADIOHMS

In values from 2 to 10,000 ohms . . . insulated construction . . . 3 watts . . . universal shaft for all replacements . . . regular Radiohm switch covers may be attached . . . in linear curve only . . .

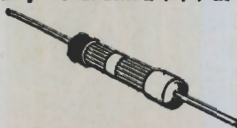

LEVER ACTION SWITCH

Used singly or in groups . . . for broadcasting, receiving, public address, test instruments and industrial uses. Available in any one of ten different combinations including positive and spring return action.

AXIAL LEAD RESISTORS

Body is insulated by inert ceramic jacket . . . proof against vibration and humidity . . . will withstand five times rated load without permanent change. In two sizes . . . RMA coded . . . $\frac{1}{2}$ watt at $\frac{1}{8}$ " x $\frac{5}{8}$ " and 1 watt at $\frac{1}{4}$ " x 1".

ADASHAFT MIDGET RADIOHM

Will handle more than 400 different makes (several thousand different models) as far as values and tapers are concerned. A valuable and ideal emergency kit.

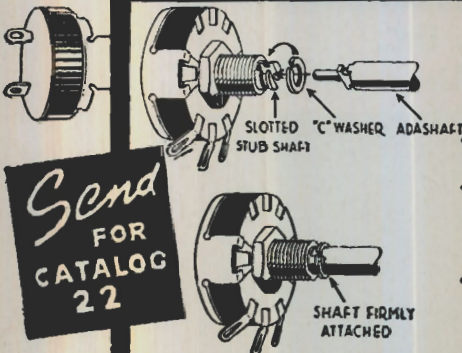

Send
FOR
CATALOG
22

- K-163 4 IN ADASHAFT, $\frac{1}{16}$ " FLAT
- K-164 4 IN ADASHAFT, $\frac{1}{8}$ " FLAT
- K-165 10 IN ADASHAFT, $\frac{1}{16}$ " FLAT
- K-166 3 IN AUTO TYPE ADASHAFT WITH GUIDE FUNNEL
- K-167 6 IN AUTO TYPE ADASHAFT WITH GUIDE FUNNEL
- K-168 10 IN AUTO TYPE ADASHAFT WITH GUIDE FUNNEL
- 1040086 SLOTTED INSULATING COUPLER
- K-168 INSULATING COUPLER WITH SQUARE HOLE

DUNCO RELAYS for AMATEUR USE

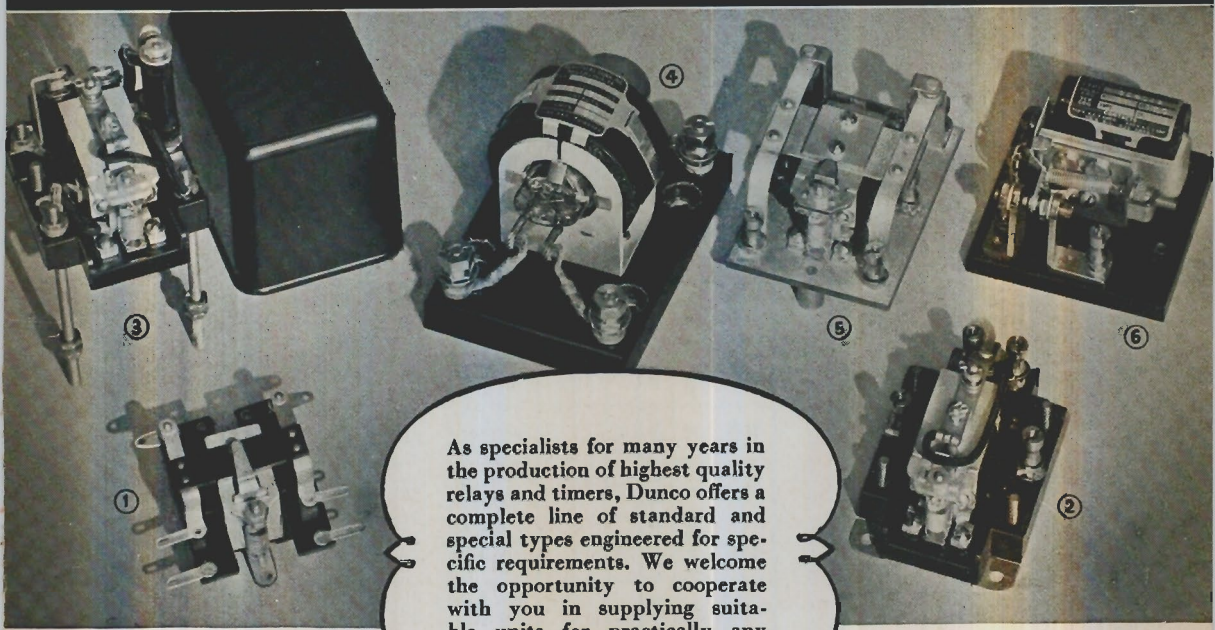

As specialists for many years in the production of highest quality relays and timers, Dunco offers a complete line of standard and special types engineered for specific requirements. We welcome the opportunity to cooperate with you in supplying suitable units for practically any application.

(1) DUNCO RADIO RELAY

Isolated contacts permit operation in high or low voltage circuits at any frequency. No feedback or hum. Unit is designed for extremely fast operation. Unexcelled for bug keying. Low contact resistance; single break contacts; high voltage and current carrying and breaking capacity; vibration-proof construction and many other features.

Type	Operates On	Amateur Net
RA1	2.5 V. 60 Cycle Coil.....	\$2.00
RA2	2.5 V. 25 Cycle Coil.....	2.00
RA3	6.3 V. 60 Cycle Coil.....	2.00
RA15	115 V. 60 Cycle Coil.....	3.50
RD1	5 to 6 V. D.C. Coil.....	2.00
RD15	10 to 12 V. D.C. Coil.....	3.00

(3) DUNCO TIME DELAY RELAYS

By connecting input terminals across primary of filament transformer, and output terminals to primary of plate transformer, power is delivered to the latter 30 seconds after filaments are turned on, thereby prolonging tube life. Unit has snap-on housing with panel mounting as illustrated for back-of-panel connection. Contacts rated 6 amps. at 115 v., a.c. 3" high, 2 1/8" wide, 2 3/16" deep including cover.

Dunco Type TD-327, Amateur Net \$8.80

Other Time Delays and Time Controls available. Tell us your requirements

(4) DUNCO MERCURY PLUNGER RELAY

This power type relay handles loads up to 30 amperes at 110 volts a.c. or 20 amperes at 220 volts a.c. Unexcelled for remotely controlled transmitters, receivers, motors, etc. The mercury tube is of the plunger type with only one moving part. It is completely silent in operation. Due to the use of mercury contacts, there is no sticking or burning of contacts. Standard coils operate on 115 volts, 60 cycles, but other coils are available. Vertical panel mounting. Size 3 1/2" high x 2 1/2" wide x 2 3/4" deep.

Dunco Type MR-1, single pole, Amateur Net \$6.00

(2) DUNCO MIDGET KEYING RELAY

A high quality relay for speeds up to 40 w.p.m. Silver button replaceable contacts will interrupt currents of 6 amps. at 110 v., a.c. Contacts are single pole, and close when coil is energized. Consumes 50 ma. at 110 v., 60 cycles. Vertical panel mounting. Handles loads to 660 watts. 2 3/4" high, 1 1/8" wide, 1 3/4" deep.

Dunco Type ASBX1, Amateur Net \$3.75

NOTE: Dunco makes many other Midget Relay Types which are described in detail in our general catalog. Among these are: ABTX1 S.P.D.B. Front Contact, \$3.75; ABTX1P S.P.D.B. Front Contact with pigtail, \$4.00; ADBX1 D.P.S.B. Front Contact, \$4.75; BSBX1 S.P.S.B. Back Contact, \$3.75; CSBX1 S.P.S.B. Double Throw, \$4.00; and CDBX1 D.P.S.B. Double Throw, \$5.25 amateur net. These do not operate as fast as Type ASBX1.

(5) DUNCO RADIO FREQUENCY RELAY

Developed for use with low power transmitters. Contacts are double pole, double throw rated 6 amperes at 500 volts R.F. Mounted on mica base and a mica cross arm insulates the moving contacts from armature. Vertical mounting. Standard coil operates on 115 volts, 60 cycles, consumes 4 watts. Other voltage coils available. Size 3" high x 2" wide x 2 1/4" deep.

Dunco Type CXA1946, Amateur Net \$5.25

(6) DUNCO VACUUM TUBE RELAY

An ultra-sensitive unit specifically designed for operation in plate circuits of small vacuum tubes. Takes d.c. in coil circuit and either d.c. or a.c. in contact circuit. S.P., D.T. contacts make one circuit when coil is energized, and another circuit when de-energized. Coil has 10,000 ohms resistance. Handles up to 18 ma. Unit may be adjusted for operation down to 1 ma. Contacts rated 2 amps. at 110 v., a.c. 2 7/8" high, 2 1/4" wide, 2" deep.

Dunco Type SD40S2, Amateur Net \$6.00

Write for details on Dunco sequence, ratchet or "step-by-step" relays.

THE DUNCO CATALOG is your guide to better relays. Lists the full line of standard and special, Dunco Relays and contains a wealth of engineering and application information. Write for your copy.



VACUUM TANK CONDENSERS

Only 6 1/2 inches long with a diameter of 3/4 inch. They are made of a special alloy of 32,000. May be used in a push pull 100% modulated transmitter operating at 4000 volts on the plate... higher voltages may be used with single ended transmitters where no modulation is required. Proper combinations of the standard units will produce any desired capacity for optimum circuit efficiency on any frequency from 20 to 50 mc per unit depending upon frequency.



Capacity	6mmfd	12mmfd	25mmfd	50mmfd
Net price	\$7.50	\$8.50	\$10.50	\$12.50

MERCURY VAPOR RECTIFIERS

	GRID CONTROL	
Filament Voltage	RX21	KY21
Filament Current	2.5 volts	2.5 volts
Peak Inverse Voltage	10 amperes	10 amperes
Average Plate Current	11,000 volts	11,000 volts
NET PRICE	\$7.50	\$10.00



Unconditionally Guaranteed Against Tube Failures Which Result From Gas Released Internally...

	3ST	35 TG	Twin 30	UH 50	75T	100 TL	100 7H	100 7H	152 Tetrode	250 TL	250 TH	304 TL	450 TL	450 TH	750 TL	1000 UHF	1500 UHF	2000 T
Filament Voltage (volts)	5	5 to 5.1	6	7.5	5	5	5	5	5 or 10	5	5	5 or 10	7.5	7.5	7.5	7.5	7.5	10
Filament Current (amperes)	4	4	4	3.25	6.5	6.5	6.5	6.5	13 or 6.5	10.5	10.5	20 or 15	12	12	21	16	26	26
Amplification Factor	30	30	32	10.6	10	12	30	...	10	13	32	10	16	30	13.5	30	18.5	18.5
Grid-Plate Capacity (mmfds)	1.9	1.7	2	2.6	2.3	2.3	2	1	5	3.5	3.5	5	4	4	4.5	4	7	9
Grid-Filament Cap. (mmfds)	4.0	1.9	1.9	2.2	2.2	2	2.2	1.3	5	3	3.5	10	4	4	6.0	6	10	13
Plate-Filament Cap. (mmfds)	2	2	2	3	3	4	3	3.7	7.5	5	3	1.5	.6	.6	.8	.6	.9	1
Bulb	T14 Nonex	T14 Nonex	T14 Nonex	S21 Nonex	G22 Nonex	G25 Nonex	G25 Nonex	G25 Nonex	G20	GT30 Nonex	GT30 Nonex	G28	GT40 Nonex	GT40 Nonex	GT36 Nonex	GT40 Nonex	GT56 Nonex	GT64 Pyrex
Base	Indolite UXA Preax	Indolite UXA Preax	Indolite UXA Preax	Indolite UXA Preax	Indolite UXA Preax	Indolite UXA Preax	Indolite UXA Preax	Indolite UXA Preax	Indolite UXA Preax	Standard 50 Watts	Standard 50 Watts	Standard 50 Watts	Standard 50 Watts	Standard 50 Watts	Standard 50 Watts	Standard 50 Watts	Standard 50 Watts	Standard 50 Watts
Overall Height (inches)	5 1/2	5 1/2	4 3/4	6 3/4	7	7 1/4	7 1/4	5 1/4	7 1/2	9 1/4	9 1/4	7 1/2	12 1/2	12 1/2	16 1/2	12 1/2	16 1/2	17 1/2
Maximum Diameter (inches)	1 3/4	1 3/4	3	2 3/8	2 3/4	3 1/8	3 1/8	2 3/4	2 3/4	3 3/4	3 3/4	3 3/4	5	5	7	5	7	8
Max. Plate Voltage (volts)	2000	2000	1500	1250	3000	3000	3000	3000	3000	3000	3000	3000	6000	6000	6000	6000	6000	6000
Max. Plate Current (millamps)	150	150	85	125	175	225	225	225	500	350	350	1000	500	500	1000	750	1250	1750
Max. Grid Current (millamps)	35	30	30*	25	30	35	60	.030	75	50	100	150	75	125	125	125	175	225
Plate Dissipation (watts)	70	70	30*	50	75	100	100	125	150	250	250	300	450	450	750	1000	1500	2000
Power Output (watts)	240	240	175	125	300	400	400	375	600	800	800	1200	1800	1800	3000	3500	5000	7500
Power Output (watts) High Level Modulated	50	50	100	100	100	350	350	...	500	500	1000	1000	2500	2500
Power Output (watts) Linear Amplifier	25	50	50	125	125	...	125	125	350	350	500	1000
LIST PRICE (NET)	\$6.00	\$6.75	\$13.50	\$12.50	\$9.00	\$13.50	\$13.50	\$28.50	\$20.00	\$24.50	\$24.50	\$66.00	\$75.00	\$75.00	\$175	\$175	\$225	\$300

CHARACTERISTICS

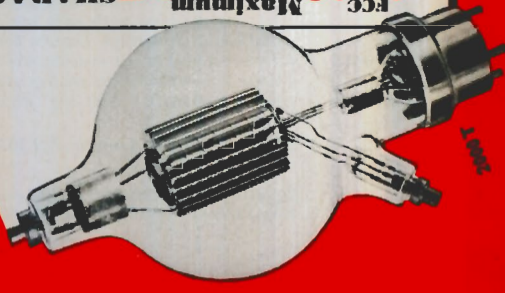

17 two tubes

*Characteristics per section

Quality above all!

Meissner

PRECISION-BUILT RADIO EQUIPMENT

The Standard of Comparison

UNI-SIGNAL SELECTOR



Connects as a speaker to the output of any receiver. Eliminates all interference in the form of QRM, QRN, Tube Hiss, etc. For CW only — can not be used on phone. Has clean, 1000-cycle note. 25-cycle selectivity — takes up where crystal leaves off.

No. 9-1026, Amateur Net.....\$13.75

DE LUXE SIGNAL SHIFTER

The accepted standard for ECO operation. Shifts your frequency to a clear spot with ease and accuracy. All-band operation; voltage-regulated for stability. Features positive oscillator keying for "break-in" operation. Complete with tubes.

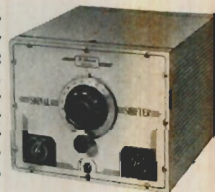

No. 9-1027, Amateur Net.....\$47.50

SIGNAL SPLICER



Designed to match any type of antenna to the input of any receiver. Where transmitting antenna is used for receiving also, this unit will provide material increase in Signal Gain. Uses no power — no tubes! Improves image rejection — reduces noise pick-up.

No. 9-1022, Amateur Net.....\$3.95

SIGNAL BOOSTER

Used ahead of any receiver, provides average gain of 40 db. Two stages of high-gain RF amplification, self-powered. Covers full range between 1.6 and 31 mc. Has RF Gain, Range, Antenna Compensator, Cut-Over Switch and Tuning Control. Complete with tubes.



No. 9-1031, Amateur Net.....\$43.50

SIGNAL RESONATOR

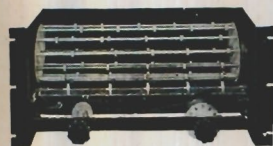

Single Control unit for YOUR transmitter! Automatically sets all condensers, band-switches, etc. to completely tune your transmitter to any of eleven desired frequencies.

Entirely mechanical, easy to install; only 3 seconds to change frequency with the Signal Resonator!

No. 9-1024, Amateur Net.....\$29.50

MC 28-56 CONVERTER

Covers 28 to 30 mc and 56 to 60 mc. Converts to 6.9-7.4 mc IF to work into any communications receiver. Uses 1852, high-gain RF amplifier. Provides consistent reception on the 5 and 10 meter bands. Voltage regulated. Complete with tubes.

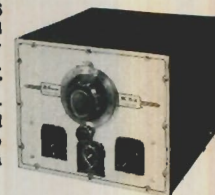

No. 9-1032, Amateur Net.....\$44.75

Write for your Free copy of the New Amateur Catalog
Read the story behind Meissner Precision-Built Equipment

Address Dept. H-41



MT. CARMEL, ILLINOIS

"A FAMOUS NAME FOR TWO DECADES"



Type BR — "Blue Beavers"

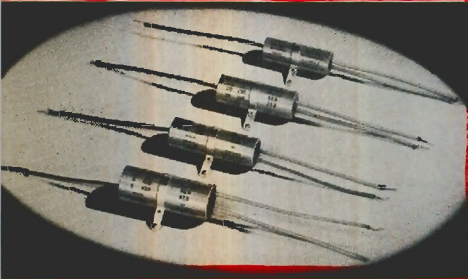

Type BRL — dual "Beavers"



Type JR, JRC and JRX



Type UP — Electrolytics



Type EX and EY



Type TJU Dykanol Capacitors

They may

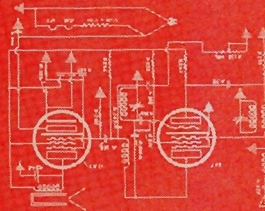

but

... put to the test, all capacitors are *not* alike. They differ in life span, in number of advanced features, in dependability. Unfortunately the eye cannot see these important differences. There is a way, however that you can be sure you're getting

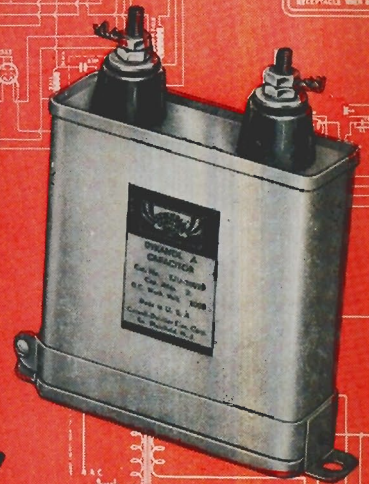

demand CORNELL - DUBILIER

MICA CAPACITORS

Widely imitated, copied but never duplicated, patented C-D micas are serving in thousands of ham rigs the world over.

DYKANOL TRANSMITTING CAPACITORS

Carefully designed, compact, light-weight, safety rated, furnished with universal mounting clamps, well insulated terminals, fire-proof, these units are without a doubt the most dependable capacitors offered the radio amateur.

PAPER CAPACITORS

C-D Tubular and Bypass Paper Capacitors have established an international reputation for outstanding dependability and economy. Available in all capacities at 400, 600 and 1000 V.D.C.

WET & DRY ELECTROLYTIC CAPACITORS

Outstanding in the complete C-D line of electrolytic is the type BR "Blue Beaver"—world's smallest 500 V electrolytic. Use "Blue Beavers"—save space, save time—get better all 'round performance.

Look alike

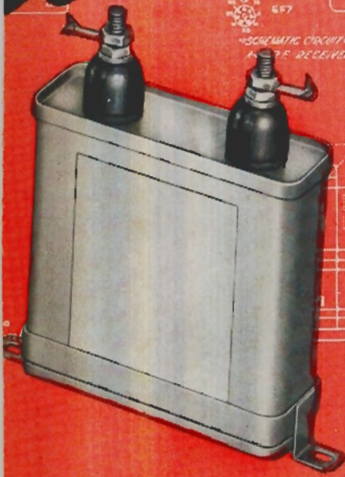

be all-around tops in capacitor value. Look for the name **CORNELL-DUBILIER** on the label. Only capacitors bearing this name are backed by laboratory *life tests* for performance, and the specialized experience of 30 manufacturing years—your guarantee of outstanding performance on the job.

CORNELL-DUBILIER

*the top name
in capacitors*

For the complete listing of all C-D Capacitors, Capacitor Test Instruments and Quietone Interference Filters, ask your local C-D distributor for Cat. 185A. Or write to Cornell-Dubilier Electric Corp., So. Plainfield, N. J.



Type TQ Dykanol Capacitors

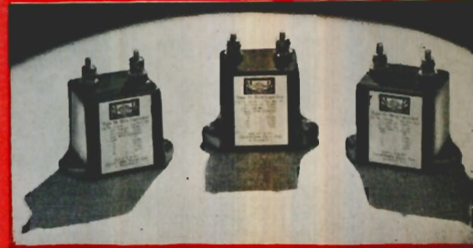

Type 86 Mica Capacitors

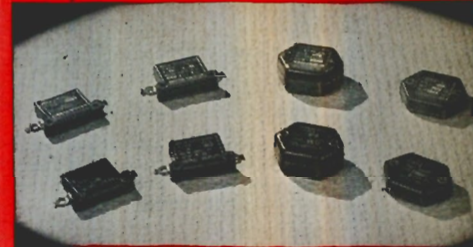

Types 4 and 9 Mica Capacitors



Type DT—"Dwarf Tigers"



Type DYR Dykanol Bypass



BE-50 Capacitor Analyzer

ARE YOU PROFESSIONAL

OR

Are You Amateur?

RME'S ENGINEERING FACILITIES ARE AVAILABLE TO THE PROFESSIONAL AND AMATEUR ALIKE

Regardless, whether your radio communication needs are for industrial application, or whether just for pleasure, there is an RME instrument to meet many specifications. Nearly a decade in the communication engineering field has given our engineers a wealth of practical information and design of new and customed apparatus. Price experience in the quotations on special on request.



HERE ARE 2 FINE, OUTSTANDING EXAMPLES OF RME SUPERIOR CRAFTSMANSHIP:

One is a universal, amateur or professional, standard communications receiver, the RME-99; the other is a new, special purpose receptor for industrial application. This latter receiver, the SPD-11, is a crystal controlled instrument incorporating 6 predetermined frequency channels.

UNIFORMITY

OF ALL RECEIVING EQUIPMENT IN YOUR STATION is possible when RME units are incorporated throughout. RME provides the steps to more accurate, efficient, and above all, STANDARDIZED reception of all communication services from 90 KILOCYCLES TO 60 MEGACYCLES.

The following chart shows the steps upon which RME instruments are classified. Choose the classification or classifications in which you are interested, then write us for specific information concerning particular units in each group!

1. STANDARD COMMUNICATIONS RECEPTION

The RME-99, 12 tube custom-built receiver incorporates every convenience and control necessary for efficient and accurate reception of all frequencies from 550 to 33,000 kilocycles. Relay rack or cabinet models are available in a variety of different voltages and currents.

2. SPECIAL LOW FREQUENCY AND AIRCRAFT RECEPTION

A number of units are available in this class. All are constructed with selective and efficient circuits for proven performance. Ask for information concerning the LF-90 FREQUENCY INVERTER and the ME-14 PORTABLE RECEIVER. (In process of design are 2 new aircraft units of particular interest to the private pilot.)

3. ULTRA-HIGH FREQUENCY UNITS

Listed in this group are complete receivers tuning all channels from 27.8 to 60.3 megacycles, ham band models, crystal controlled spot-frequency police units, EXPANDER UNITS for conversion of standard communication receivers to efficient high frequency reception, and receivers especially designed for remote pick-up service.

4. INDUSTRIAL AND COMMERCIAL RADIO DEVICES

This classification includes forest service units, crystal controlled receivers such as the SPD-11 (above), oscilloscope amplifiers, and other electronic instruments. In this group, also, are classed special units made up to individual specifications.



RME
TIME WILL TELL
RME

Detailed Information Is Available without Obligation

Fine Communications Equipment

RADIO MFG. ENGINEERS, Inc.

111 HARRISON ST.

PEORIA, ILLINOIS



Among the Finest Semi-Automatic Radio and Telegraph Keys
Genuine

Preferred by good operators the world over for its clarity . . . speed . . . sending ease.

VIBROPLEX

THE LIFETIME KEY



The "CHAMPION"
ONLY \$9.95

Like all real champions this New Vibroplex "CHAMPION" defies competition. Attractive design, sturdily built and a "STAR" performer. Standard size black crystal base with polished chromium top parts. $\frac{3}{16}$ " contacts. Furnished without circuit closer, cord and wedge for radio use only.

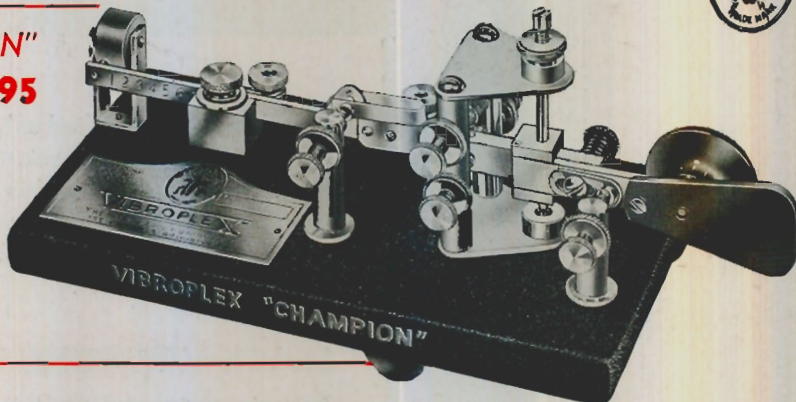

VIBROPLEX "Original" Model

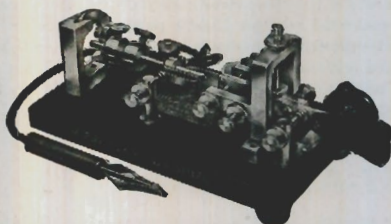

Here's a key liked by every brass-pounder who has ever used it. Smooth, easy action — this is the type of key an expert operator needs when he has a tough sending assignment, because he knows from experience that it will handle the job quicker, better and with less effort. Suitable for both Morse and Radio. $\frac{3}{16}$ " contacts. Standard finish, \$15.95. De Luxe, \$19.50.

VIBROPLEX "Blue Racer" Model



Similar to the "Original" Vibroplex but only half the size. Tucks away in small space and is a handy, reliable and efficient key for all classes of telegraph work. Embodies the same sending

possibilities, the same strength and durability as the Standard size keys. $\frac{3}{16}$ " contacts. Standard finish, \$15.95. De Luxe, \$19.50.

New 1941 Vibroplex Keys

The New 1941 Vibroplex Semi-Automatic Keys are the smartest, smoothest, easiest to operate keys Vibroplex has ever produced. Standard finish includes Polished Chromium top parts with black base. De Luxe finish includes Polished Chromium top parts and base, colorful red switch knob, finger and thumb pieces and a green silk cord. For a limited time, De Luxe models are being equipped with Patented JEWEL Movement without extra charge. Jeweled movement insures a lifetime of dependable service and ease of operation not possible in any other key. The 1941 Vibroplex keys also include DIE CUT dot contacts and main springs insuring uniform length and tensile strength at all times.

VIBROPLEX "Lightning Bug" Model

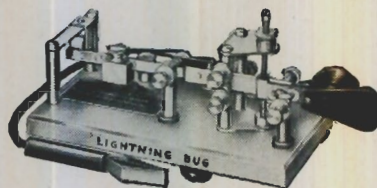

This GREAT NEW DESIGN VIBROPLEX is one of the smartest, smoothest, easiest-working keys ever produced. It is popular with both Morse and Radio operators because of its strong, clear signal, precision adjustment and ease of manipulation. Maintains the same high quality signal at all speeds. Embodies many features not found in any other key. $\frac{3}{16}$ " contacts. Standard finish, \$13.95. De Luxe, \$17.50.

Write for New Illustrated Catalog showing complete line of Vibroplex keys including the New Sensational 1941 Patented Jewel Movement Vibroplex in color.

CARRYING CASE

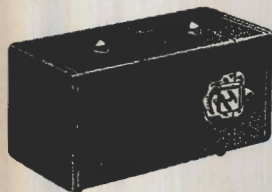

Plush lined. Finished in black morocco. Reinforced corners. Flexible leather handle. Lock and key. \$3.50.

THE VIBROPLEX CO., INC.

832 Broadway, New York, N. Y.

J. E. Albright, President

Commercial-Grade TRANSMITTING CAPACITORS

● Heretofore supplied only to Army and Navy, commercial communication companies and broadcasters, and to builders of quality radio and electronic equipment, Aerovox now makes available to "hams" this extra-quality line. Here are typical mica items . . .

STACK-MOUNTING HEAVY-DUTY

● For such applications as grid, plate-blocking, coupling, tank and by-passing in high-powered "rigs." Low-loss glazed ceramic casing provides long creepage path between cast-aluminum terminals. Corona losses eliminated inside and out. Uniform voltage gradient. Low contact resistance between stacked units. India ruby mica sections made to closest tolerances to equalize loading of series-connected sections. Rigidly clamped in low-loss non-magnetic clamps. Heat-treated for maximum capacity-temperature stability. Vacuum-impregnated sections imbedded in low-loss filler, reducing stray losses and barring moisture penetration. Five sizes. .00001 to .5 mfd. 1000 to 35,000 test volts effective.

CAST-ALUMINUM CASE

● Mica capacitors especially suited to applications requiring shielded capacity with one terminal grounded. Completely shielded from stray fields of nearby components. Corona losses avoided by a stack construction and grounded case. High-tension Statite pillar terminal. .000025 to .1 mfd. 1000 to 6000 test volts effective.

BAKELITE-CASE AND MOLDED

● Large bakelite-case mica capacitors especially for ultra-high-frequency applications. Handling elevated voltages and higher current ratings. Non-magnetic clamping of mica sections. Vacuum-impregnated stack assembly with low-loss filler. .00001 to 1.0 mfd. 250 to 8000 test volts effective.

. . . and OTHER TYPES

● Also extra-heavy-duty oil capacitors, a wider choice of wax-filled paper condensers, plug-in electrolytics and paper capacitors, etc., etc.

Ask Your Local Jobber . . .

● Consult him about those extra-heavy-duty capacitor problems. He'll go over our special engineering data with you and help you select just the capacitors you require.

AEROVOX CORPORATION
New Bedford, Mass.



Sales Offices in All Principal Cities

IN NATIONAL DEFENSE ... OR PRIVATE INDUSTRY

CARDWELL CONDENSERS

Are always well represented



CARDWELL condensers never fail to justify their choice for finest commercial equipment, reflecting the prestige of the product of which they become a part.

**THE ALLEN D. CARDWELL
MANUFACTURING CORPORATION**
85 PROSPECT STREET, BROOKLYN, NEW YORK

HOWARD Comm

HOWARD Progressive Series

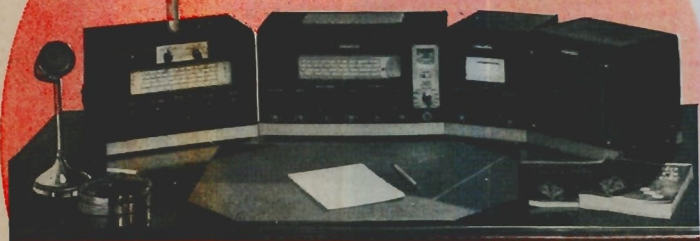

Impressive in appearance—tops in performance and ease of operation. Can be started with basic Model 435 on the Progressive Series Plan. Gives you the advantage of a modest investment with the privilege of adding to your equipment at any time you desire.

Approval Ever

Quality at a price that isn't "loaded" will always command a buyer's attention. That's why HOWARD Communication Receivers sell in steadily growing volume. Every HOWARD Receiver is truly a triumph of design, performance, beauty and engineering craftsmanship—each developed to meet the exacting operating demands of today and tomorrow.

**You Can Start It with a \$29⁹⁵
PROTECTED INVESTMENT**

ALL MODELS HAVE FOUR

650 PRESELECTOR

The performance of this high gain two stage RF pre-amplifier, using 1853 tubes, is truly remarkable in increasing DX and in reducing signal interference. Self powered, with exclusive loop arrangement reading directly in degrees of the compass, this important unit of the HOWARD Progressive Series can be effectively used with any type or make of receiver. The master selecting system provides operation with loop or external antenna or cuts out pre-selector for regular operation of receiver. Price complete, but **\$29⁹⁵** without loop.

(Loop Antennas—\$7.50)



MODEL "437"

Extremely sensitive and selective—is an outstanding performer on all bands. It features: 9 tubes, RF stage on all 4 bands, two iron core IF stages, Noise Limiter, Crystal Filter, BFO, Electrical Band Spread, exclusive HOWARD Inertia Knobs, and all other desirable refinements. Exact Carrier Level Meter, an entirely new device for measuring input signal strength in microvolts, can be installed on any HOWARD Progressive **\$54⁵⁰** model for \$12.00.

(With Crystal—\$62.00)



660 FREQUENCY MONITOR

Enables you to read directly in frequency, any unknown signal in the amateur bands. Ceramic insulated precision built variable condenser carries an extremely accurate frequency scale. Frequency can be read within one kilocycle on the lower frequency bands and within five kilocycles on the 10 meter band. Highly stabilized, has built in power supply and will operate with any receiver. **\$18⁹⁵** Complete price.



HOWARD RADIO COMPANY

America's Oldest Radio Ma

1731-35 E
Cable Ad

Communication Equipment

Amateurs Everywhere!

Owners everywhere have acclaimed the abundance of exclusive features found in the 1941 HOWARD Communication Receivers. Dollar for dollar, the outstanding performance of these great receivers is representative of America's finest values. Be sure to personally see the brilliant new HOWARD Models before you buy any receiver.

BANDS—540 KC. to 43 MC.

MODEL "436"

Providing more features than Model 435, but lower in cost than Model 437, the HOWARD 436 is the answer to outstanding performance in the medium price range. A seven tube receiver containing all features of basic Model 435, plus an efficient noise limiter, a new eight inch band spread micrometer dial and exclusive HOWARD Inertia tuning controls which provide fly-wheel tuning on both main and band spread dials. A remarkable value. **\$39⁹⁵**



Howard Model "490"

For those desiring a single unit receiver that establishes new standards of performance the new 14 tube HOWARD 490 is outstanding in every respect. Has sensitivity that never knows crowding and selectivity that may be varied at will from the hairline sharp position required for CW to wide range for high fidelity reproduction. 2 RF stages, calibrated band spread, 8 position variable IF selectivity, air-tuned IF transformers, temperature compensated oscillator, automatic noise limiter, variable audio fidelity, 8 watt push-pull output. Comes complete with 14 tubes, crystal filter and 10 inch external dynamic speaker in matching cabinet.

**One of the World's
FINEST RECEIVERS \$149⁵⁰**

MODEL "435"

HOWARD Model 435 is the basic unit of the HOWARD Progressive Series, features six tubes, separate electrical band spread condenser, ceramic coil forms, built in 6½ inch electrodynamic speaker, BFO, iron core IF coils, copper plated chassis and silver plated shielding. The slide rule dial is silver plated and well illuminated. A band-in-use-indicator is at the left of the main dial with electrical band spread at the right. **\$29⁹⁵**



PROGRESSIVE SERIES PLAN

HOWARD'S revolutionary direct factory conversion set-up, applicable to Models 435, 436 and 437, enables you to own at all times our latest receiving equipment — without loss or unfavorable trade-in deals. It is the most flexible and all-in-your-favor purchase plan in existence. Inquire today!

mont Ave., Chicago, Ill.
ess: HOWARDCO., U. S. A.

u f a c t u r e r

**SEE THESE HOWARD RECEIVERS
AT YOUR DISTRIBUTOR TODAY!**

Export and Pacific Coast Prices Slightly Higher

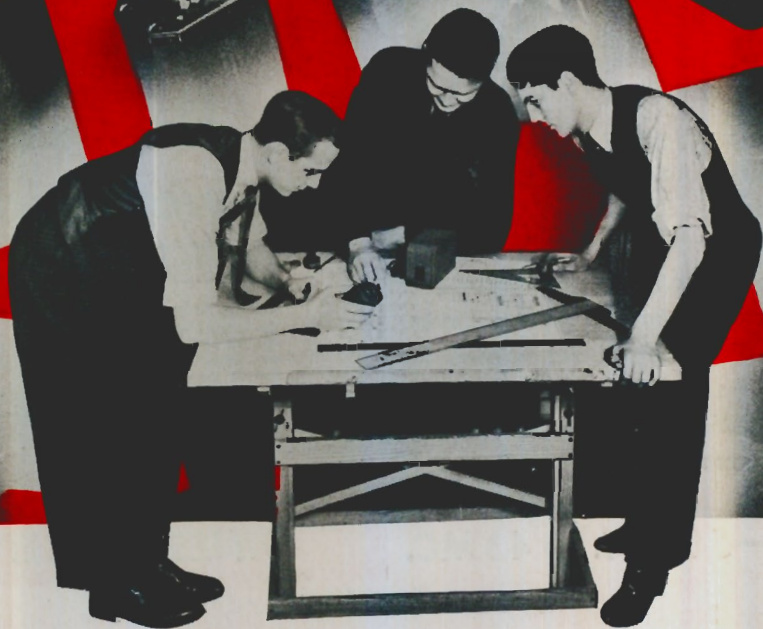

The Word Is Getting Around...

"For national defense or private industry . . . where dependability and adherence to specifications are essential . . . transformer users turn to UTC."

THERE IS NO SUBSTITUTE FOR EXPERIENCE

*Whether STANDARD or SPECIAL
UTC has a transformer for every purse and purpose*

UNITED TRANSFORMER CORP.

Write: COMMUNICATIONS DIV. ★ 150 VARICK ST. ★ NEW YORK, N. Y.
EXPORT DIVISION: 100 VARICK STREET NEW YORK, N. Y. CABLES: "ARLAB"



WALTER H. CANDLER
Originator of the famous CANDLER
SYSTEM and founder of the Cand-
ler System Company.



LEARN OF SPEED UP YOUR CODE at Home

With the NEW CANDLER SYSTEM

TRAINS YOU TO MEET NEW CODE SPEED REQUIREMENTS

Obtain Your Amateur or Commer- cial License in 1/2 Usual Time With The New CANDLER SYSTEM Training

You Can Learn Code RIGHT, from the beginning as you will be using it on the air, or obtain your commercial license and qualify for a good

job by taking CANDLER TRAINING in your own home, as McElroy, Jean Hudson, McDonald and many others have done and are doing. It is surprisingly easy and inexpensive.

It takes more than merely the sending and receiving of code to become a skilled radiotelegraph operator. The New CANDLER SYSTEM teaches you quickly the technique of Fast, Accurate telegraphing.

LEARN AT HOME To Read Code at High Speeds Like You Read Print

If you've practiced and practiced with any kind of practice set, but can't get over the "hump" that seems to be your limit — don't be discouraged. Thousands of skilled operators have had the same experience. Some thought they were dumb; others thought they weren't "gifted." But you should see those fellows today! They can send beautiful code and copy fast press 4 to 8 words behind without conscious effort or strain. Those fellows have *Automatic Sound Consciousness* — and they got it through CANDLER Training!

No Expensive Practice Sets Needed for Candler Training

Learning to Send and Receive Code Rapidly, skillfully is a Mental Process that requires Mind Training such as only CANDLER can give you. Practice of any kind without this Specialized Training is like trying to learn electricity without a knowledge of *Ohm's Law*. CANDLER shows you the easy, interesting way to Speed, Skill, and that Amateur or Commercial License in half the usual time.

CANDLER SYSTEM

Box 331, Dept. LM-40
ASHEVILLE, N. C., U.S.A.



T. R. McELROY

Official Champion Radio Operator, Speed 75.2 wpm., won at Asheville Code Tournament July 2, 1939, says: "My skill and speed are the result of the exclusive, scientific training Walter Candler gave me. Practice is necessary, but without proper training to develop Concentration, Co-ordination and a keen Perceptive Sense, practice is of little value. One likely will practice the wrong way."



JEAN HUDSON, W3BAK

At the age of 9, after taking Candler code training, Jean won the championship in Class E, at Chicago World's Fair.



L. R. McDONALD, W8CW

At the Asheville Tournament copied 75 wpm. McDonald says: "Without Candler scientific training and specialized practice, I could never have made my record of 75 wpm. Candler fundamental training is necessary to speed and skill."



Champion Jean at the age of 14 when she won the championship in Class B at the Asheville Code Tournament.

SEND FOR THIS FREE

BOOK OF FACTS

It gives you the story of the champions and many inside tips that will help you. It is FREE, a postal will bring it to you. No obligation.



B & W AIR IN VARIABLE AIR

Announcing! . . .

B & W TYPE CX VARIABLE AIR CONDENSERS

Improved in Design! Sturdier in Construction! The Practical Basis for a Symmetrical Amplifier Tank Circuit!

LOOK AT THESE FEATURES! . . . (1) Improved, sturdy construction, employing heavy nickel-plated end plates. (2) Heavy, highly polished aluminum plates with well-rounded edges increase breakdown voltage. (3) Alsimag 196 insulation throughout. (4) Built-in neutralizers. (Optional.) (5) Built-in coil mounting. (Optional.)

★ High maximum-to-minimum ratios. ★ Improved basic design shortens and even eliminates some leads. ★ Absence of tie-bars prevents short-circuited loops. ★ Large brush and disc self-wiping rotor contact. ★ Short, heavy rotor reduces r-f path. ★ Only half the length of conventional dual condensers. ★ Perfect physical and electrical symmetry. ★ Extremely compact. ★ A complete amplifier plate circuit assembly. ★ Stock types available in 0.500" and 0.250" plate spacing. ★ Special types obtainable on order.

B & W TYPE CX VARIABLE AIR CONDENSERS are available at your local jobber's. Literature giving complete technical information and prices is in preparation as the Radio Amateur's Handbook goes to press. Write for your copy.

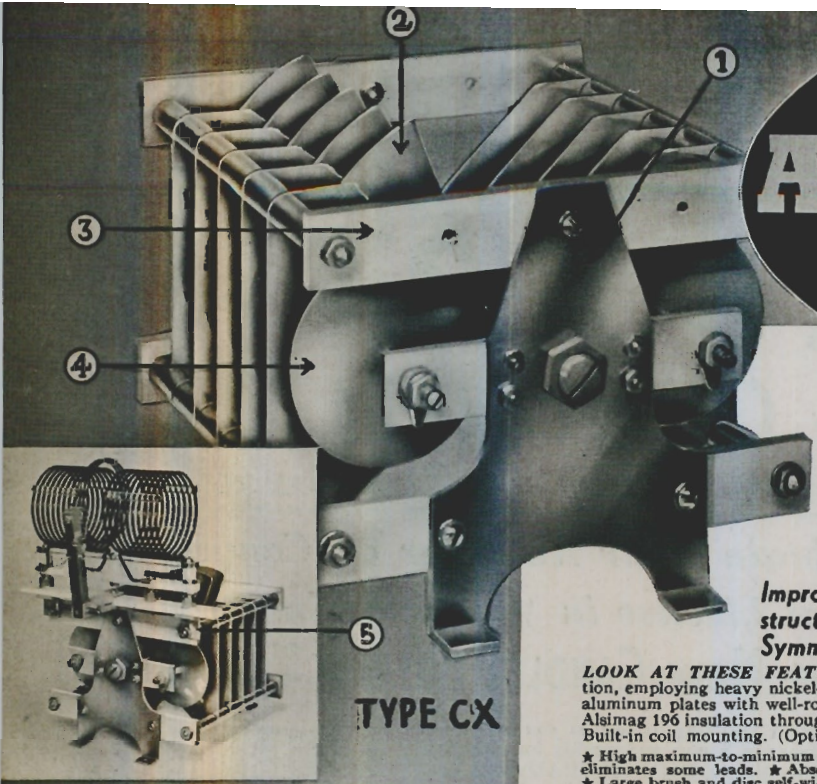

TYPE CX

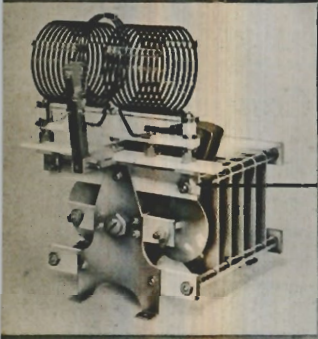

BCL



B & W 100-WATT, 5-BAND TURRETS

BCL — Center Linked, Center Tapped Coils. **BEL** — End Linked Coils
These B & W 100-Watt Turrets set new highs in fast, positive band switching on the 10- to 160-meter bands. Equal in efficiency to the best individual plug-in coil systems, yet extremely compact — $7\frac{1}{2}$ " high; $7\frac{1}{2}$ " wide; depth behind panel, $4\frac{1}{2}$ "; shaft extension, 1". They may be used with tubes operating at 1,000 to 1,250 volts and a maximum input power of 165 watts. Each unit comes complete with frequency-marked dial plate, lockwasher and nut. It may be mounted directly on the panel in a single $\frac{3}{4}$ " hole. Amateur net \$8.50 each

B & W BAND SWITCHING ASSEMBLIES

B & W "BAND-HOPPERS" (25 and 50 Watt Rating). These reliable, practical units are now available in two completely redesigned units . . . improved throughout. Cover all five bands, yet require very little space. Panel control.

B & W "BABY" TURRETS (25 Watt Rating). Compact, practical 5-band switch units for low-power transmitters and exciter stages. Cover amateur bands from 10 to 160 meters. Their exclusive B & W design assures permanent coil alignment and maximum efficiency with a minimum number of tubes.

MODEL 2A — (25 Watt Rating) — For interstage coupling with beam power tubes. \$3.25 net

BTCL, Center Linked. **BTEL**, End Linked. Amateur Net, any type. \$5.25

MODEL 2AB — (50 Watt Rating) — For interstage coupling between beam power tubes and triodes or high-powered beam tubes. \$3.50 net

MODEL B TURRET
100 Watt rating. For rapid 3-band selection from front of panel. Net Price (5 coils) \$7.50

B & W LOW-POWER COILS

B & W "BABIES" (25 Watt Rating). Ideal units for crowded layouts, portables and field transmitters. Made by an exclusive B & W process which assures maximum ruggedness, uniform air-spacing and excellent appearance in an amazingly small coil. Their 25-watt rating is very conservative.

B & W "JUNIORS" (75 Watt Rating). JUNIORS far surpass, in ruggedness and efficiency, most of the larger, more bulky coils of comparable rating. Designed for optimum performance in oscillator, buffer, or amplifier stages operating at input powers up to 75 watts and plate voltage to 850 volts.

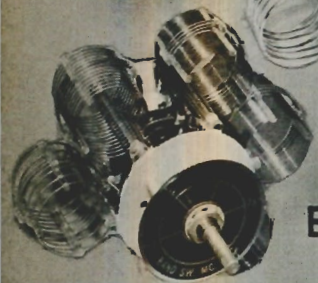

BTCL



2A



2-AB

Band	Straight Coil	Center Tapped	End Linked	Center Linked	Inductance (Microhenrys)	Capacity (pF)
160 M	MC	MEL	MCL	32	100	
80 M	MC	MEL	MCL	44	48	
40 M	MC	MEL	MCL	14	35	
20 M	MC	MEL	MCL	4.2	28	
10 M	MC	MEL	MCL	1.1	28	

Amateur Net Price \$7.50 each



MCL



JCL

BARKER &

ARDMORE, PA.

Export Address:

* Total effective capacity required to effect

WILLIAMSON INDUCTORS CONDENSERS

HDVL

TVH

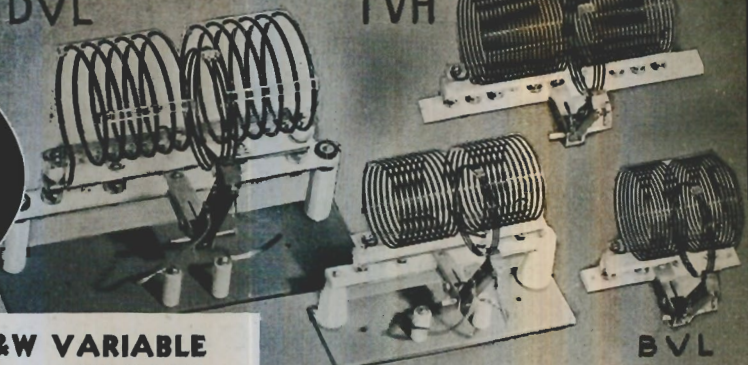

B&W VARIABLE LINK ASSEMBLIES

TYPE HDVL - 1 K.W. RATING

Type	Inductance Microhenrys	*Capacity MMfd.	Wire Size	Dia.	Outside Plug Centers	Net Price
160HDVL	94.0	90	14	3 1/2"	7 1/2"	\$5.25
80HDVL	47.0	44	10	3 1/2"	7 1/2"	4.50
40HDVL	18.0	28	8	3 1/2"	7 1/2"	4.00
20HDVL	5.2	25	8	3 1/2"	7 1/2"	3.75
10HDVL	1.3	25	4	2 1/2"	7 1/2"	3.25
HDV Base Assembly						5.00

TYPE TVH - 500 WATTS RATING

160TVH	90	90	16	2 1/2"	6"	\$2.85
80TVH	40	50	14	2 1/2"	6"	2.85
40TVH	16	32	12	2 1/2"	6"	2.85
20TVH	5.7	22	12	2 1/2"	6"	2.85
10TVH	1.35	22	6	2 1/2"	6"	2.85
TVH Base Assembly						3.75

TYPE TVL - 250 WATTS RATING

160TVL	94.0	90	18	2 1/2"	5"	\$2.25
80TVL	38.0	55	14	2 1/2"	5"	2.15
40TVL	15.0	34	12	2 1/2"	5"	1.90
20TVL	4.6	28	12	2 1/2"	5"	1.65
10TVL	1.5	22	6	2 11/16"	5"	1.60
TV Base Assembly						4.00

TYPE BVL - 100 WATTS RATING

160BVL	90	100	20	2 1/2"	3 1/2"	\$2.10
80BVL	38	50	16	2 1/2"	3 1/2"	1.90
40BVL	13	40	14	2 1/2"	3 1/2"	1.65
20BVL	4.8	25	14	2 1/2"	3 1/2"	1.45
10BVL	2	25	8	2 1/2"	3 1/2"	1.40
5BVL	0.5	25	8	1 1/2"	3 1/2"	1.35
BV Base Assembly						2.50

B&W ANTENNA COILS

TYPE HDA - 2 K.W. RATING - TYPE TA - 650 WATTS RATING

160HDA	94.0	90	14	3 1/2"	7 1/2"	\$6.25
80HDA	40.0	50	10	3 1/2"	7 1/2"	5.50
40HDA	15.0	35	8	3 1/2"	7 1/2"	5.00
20HDA	4.2	29	8	3 1/2"	7 1/2"	4.75
10HDA	1.3	25	4	2 1/2"	7 1/2"	4.25
160TA	80	100	16	2 1/2"	5"	2.85
80TA	35.0	60	14	2 1/2"	5"	2.65
40TA	13.5	38	12	2 1/2"	5"	2.40
20TA	4.3	30	12	2 1/2"	5"	2.15
10TA	1.3	25	12	2 1/2"	5"	2.10

A68 - Pi-Network Coil Complete with Clip.....\$1.85

B&W STANDARD AND FIXED LINK COILS

TYPE HD AND HDL - 1 K.W. RATING

Standard Type	Net Price	Linked Type	Net Price	Inductance Microhenrys	*Capacity MMfd.	Wire Size	Dia.	Outside Plug Centers
160HD	\$4.25	160HDL	\$6.25	94.0	90	10	5"	7 1/2"
80HD	1.55	80HDL	5.50	40.0	50	10	3 1/2"	7 1/2"
40HD	3.00	40HDL	5.00	15.0	35	8	3 1/2"	7 1/2"
20HD	2.75	20HDL	4.75	4.2	29	8	3 1/2"	7 1/2"
10HD	2.25	10HDL	4.25	1.3	25	4	2"	7 1/2"

TYPE T AND TL - 500 WATTS RATING

160T	\$1.85	160TL	\$2.85	74.0	115	12	5"	5"
80T	1.45	80TL	2.40	35.0	60	12	3 1/2"	5"
40T	1.40	40TL	2.40	13.5	38	12	2 1/2"	5"
20T	1.15	20TL	2.15	4.3	30	12	2 1/2"	5"
10T	1.10	10TL	2.10	1.3	25	12	2"	5"

TYPE BX AND BXL - 250 WATTS RATING

160BX	\$1.80	160BXL	\$2.80	84.0	100	14	4"	4"
80BX	1.65	80BXL	2.60	37.0	54	14	3 1/2"	4"
40BX	1.35	40BXL	2.35	10.0	51	14	2 1/2"	4"
20BX	1.10	20BXL	2.10	2.8	45	14	2 1/2"	4"
10BX	1.05	10BXL	2.05	1.0	35	12	2"	4"

TYPE B AND BL - 100 WATTS RATING

160B	\$1.75	160BL	\$2.50	78.0	110	18	2 1/2"	3 1/2"
80B	1.60	80BL	2.30	39.0	52	16	2 1/2"	3 1/2"
40B	1.30	40BL	2.05	12.0	43	14	2"	3 1/2"
20B	1.05	20BL	1.80	3.0	40	14	2"	3 1/2"
10B	1.00	10BL	1.75	1.1	28	12	2"	3 1/2"

B&W UNMOUNTED COILS

No. 1 - 2 1/2" Dia., 10" Length, 6 turns per inch, No. 12. Net Price.....\$1.50
 No. 2 - 2 1/2" Dia., 10" Length, 8 turns per inch, No. 14. Net Price..... 1.50
 No. 3 - 2" Dia., 10" Length, 10 turns per inch, No. 16. Net Price..... 1.50

resonance on low frequency end of specified band.

TVL

BVL

HDL

HD

T

TL

BXL

BX

BL

B

A68

HDA

TA

To Manufacturers of Products Used in Short-Wave Radio Communication

THE RADIO AMATEUR'S HANDBOOK is the world's standard reference on the technique of short-wave radio communication. Now in its eighteenth annual edition, it is universally used by radio engineers as well as the thousands of amateurs and experimenters for whom it is published. Year after year, each succeeding edition has sold more widely than its predecessor, until the Handbook now has a world-wide annual distribution in excess of sixty-five thousand copies of its English and Spanish editions. To manufacturers whose integrity is established and whose products meet the approval of the American Radio Relay League technical staff, we offer use of space in the Handbook's Catalog-Advertising Section. Testimony to its effectiveness is the large volume of advertising which the Handbook carries each year. It is truly the standard guide for amateur, commercial and government buyers of short-wave radio equipment. Particularly valuable as a medium through which complete data on products can be made easily available to the whole radio engineering and experimenting field, it offers a surprisingly inexpensive method of producing and distributing a creditable catalog, accomplishes its production in the easiest possible manner, and provides adequate distribution and permanent availability impossible to attain by any other means. We solicit inquiries from qualified manufacturers who wish full data for their examination when catalog and advertising plans are under consideration.

ADVERTISING DEPARTMENT . . .

American Radio Relay League
WEST HARTFORD, CONNECTICUT

Speaking of RESISTANCE . . .



★ Above: Midget Composition-Element Control and Plug-In Resistor Tube. Control reflects latest developments and refinements. Comparative tests invited. Ad-A-Switch permits use with or without power switch. 1000 ohms to 5 megohms. Choice of tapers. ★ Plug-In Resistance Tube — an original Clarostat development — provides ideal voltage-divider network in minimum bulk.



★ Left: New Clarostat Power Rheostat. Radically different. Selected resistance wire wound on insulated aluminum strip and imbedded in cold-setting inorganic cement. Ceramic casing. Graphited-copper shoe. Tripod rotor. Smooth, positive operation. Comparative tests invited. 25-watt rating. Popular resistance values.

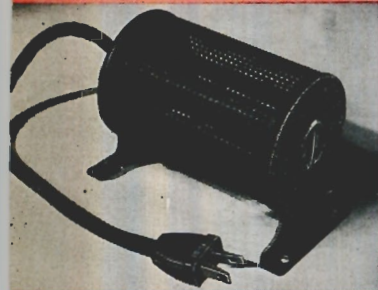

★ Right: Wire-Wound Controls identical to those used by U. S. Govt., Bell Labs., G. E., NBC, Columbia, Crosley and other critical buyers. Thoroughly dependable rheostats or potentiometers for delicate control purposes yet capable of handling considerable current. Ad-A-Switch. 1 to 100,000 ohms. All tapers. Dual and triple types; faders; L-pads, T-pads, mixers, etc.

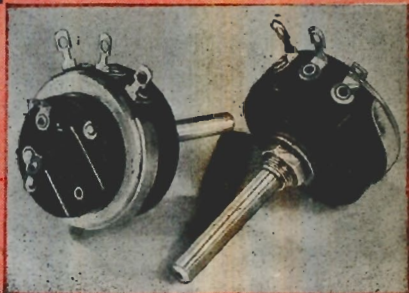

★ Left: For distortionless control of loud-speaker volume, Clarostat offers Constant-Impedance Output Attenuators in the 25-watt (Series CIA, illustrated) and 10-watt (Series CIB) ratings. Dissipate full wattage at any setting. Stock ohmages: 8, 15, 50, 200, 250 and 500. Larger unit comes with or without power switch.

★ Above: Widest choice of voltage-dropping resistors and ballasts. Here shown is a typical Clarostat job — a general-utility 75-watt line-voltage-dropping resistor with plug-in cord and Edison female receptacle. Clarostat line ballasts regulate applied voltage within narrow limits despite wide line-voltage fluctuations.

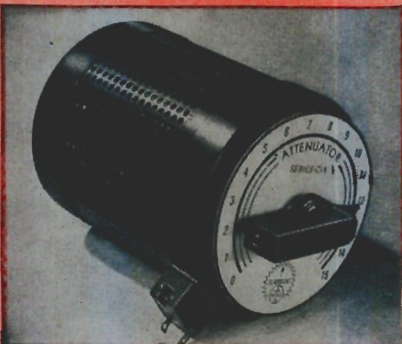

★ Greenohms — superior inorganic-cement-coated power resistors in the characteristic green finish — are now found in the very finest assemblies. Check this statement for yourself! 10 to 200 watts. Fixed or adjustable (Right). Also in Non-Inductive Series Z (Left) in 10-, 25-, 50- and 100-watt, all popular resistance values.



★ Ask your local supplier for those Clarostat items you need. Ask for latest literature. Or write us direct.

CLAROSTAT *Manufacturing Co. Inc.*



285-287 NORTH SIXTH STREET
BROOKLYN, NEW YORK, U.S.A.

• OFFICES IN PRINCIPAL CITIES •

RADIO TELEGRAPH APPARATUS *Manufactured by*

WORLD'S CHAMPION RADIO TELEGRAPHER

AUTOMATIC EQUIPMENT for TRANSMITTING and RECEIVING

Write for sheet describing Mac's astounding device which automatically keys local oscillator or another transmitter on the incoming signal. It is positively amazing! RETRANSMITTER, Model No. 1400, \$75.00 net to operator complete, nothing else to buy.



MAC AUTO

Relay for external keying is actuated by RCA-923 photo tube in circuit using two 117Z6GT and one 117N7GT. Employs ordinary ink recorder slip. Each roll of slip runs about one solid hour at 20 words per minute. Slip is on 400' 16mm. reels.

MODEL PCT811A at... \$29.50

Variable speed tape puller for either Auto or Recorder.

MODEL CTP1300 at... \$29.50

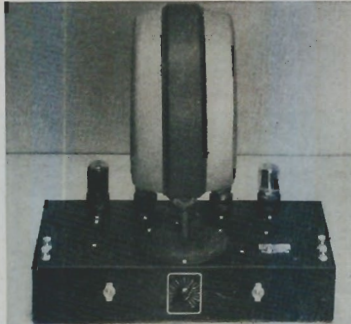

MASTER TONE SOURCE

Designed for Government radio operator schools. Finest combined audio oscillator and amplifier currently economically available. About ten watts output. Tone control; volume control. Output may be keyed by any number of keying devices for any number of groups of student headphones.

MODEL G-700 at... \$29.50



MAC RECORDER

Commercial quality ink recorder for direct coupling to radio receiver. Equipped with heavy pen for desired black line for running through Mac Auto if desired. Perfect recording speeds beyond 200 wpm. Model RRD900. Lower priced model AR900 turns out excellent slip direct from receiver or by local keying but good only for about 50 wpm.

MODEL RRD-900 at... \$75.00

MODEL AR-900 at... \$29.50

WRITE ME FOR COMPLETELY DESCRIPTIVE MIMEOGRAPHED SHEETS ON ALL ITEMS

GOVERNMENT SCHOOL TYPE COMPLETE UNITS G813 AND G913 @ \$75.00 EACH

G-813 consists of the PCT811A and CTP1300 with motorized take up reel, all mounted on one base. G913 consists of the AR900 and CTP1300 with motorized take up reel, likewise all mounted on one base. Ink recordings of student sending made with G913 may be run through G813 to correct errors and improve sending. 65 rolls of practice slip for G813 immediately available, each roll runs one hour at 20 wpm. Rolls 51 to 65 are U. S. Army training rolls and highly desirable for Army, Navy or NYA schools. Rolls \$1.00 each.

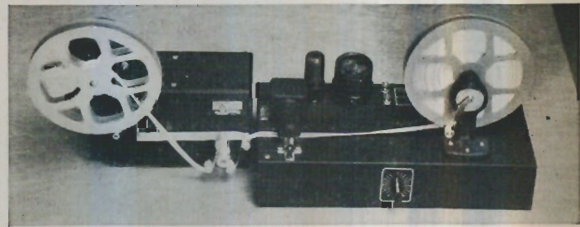

• The Amazing OSCILLATONE

More than 10,000 oscillators built for operators during the past four years and one improvement after another has finally culminated in a genuine masterpiece.

• Beautiful plastic cabinet developed by the same artist who designed the "Super Stream-speed."

Truly an outstanding piece of equipment that belongs on every operator's desk.

MODEL No. S700—NET TO THE OPERATOR \$5.95 MINUS TUBE Uses 117N7GT

OSCILLAFONE MODEL No. CR-700 @ \$2.85 net to the operator. An exceptionally fine quality speaker designed expressly for key-clickless dots and dashes. Housed in this same pretty plastic cabinet.

T.R. McElroy

100 BROOKLINE AVENUE



BOSTON, MASS.

RADIO TELEGRAPH APPARATUS *Manufactured by*

WORLD'S CHAMPION RADIO TELEGRAPHER



NEW SUPER STREAM-SPEED

S-600-PC **\$11.85**
Platinum Contacts
S-600-SC **9.50**
Silver Contacts

Into this gorgeous speed key has gone Mac's 30 years operating experience supplemented by the finest engineer-

ing ability in the radio-telegraph industry . . . with their combined efforts coordinated under the styling genius of one of America's outstanding design artists. See it! Handle it! You'll have to own it! Combining beauty and utility in a most striking fashion, this radically new, semi-automatic key is the last word in operating ease. Fast, rhythmical Morse is a real pleasure with this key.

- Streamlined base of special dense alloy. Wt. 4 lbs.
- Tear-drop shaped base makes it immovable on table.
- Heavily chromed with bluish tinge to prevent glare.
- Stainless steel coil springs and bearings.
- Beryllium copper mainspring and U spring.
- Bronze bearing screws.
- Bronze alloy pigtail.
- Bakelite insulation throughout.
- Molded plastic dot paddle and dash button.

PROFESSIONAL MODEL, MAC KEY

Designed to conform with United States Navy specifications for "speed key."

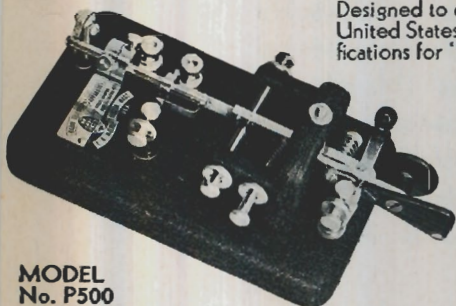

MODEL No. P500 **\$7.50**
NET TO THE OPERATOR

ness. Beautifully black wrinkled over Parkerized base casting. Carefully designed super-structure, similarly finished.

Chromed parts, circuit closer, bakelite insulation, 3/16" silver contacts. A key that will thrill any radio or telegraph operator.

It is just what its name implies: A fine Professional Operator's model Mac Key. Base 3 3/4" x 6 1/2" x 3/4" thick-

DELUXE MODEL, STREAMKEY

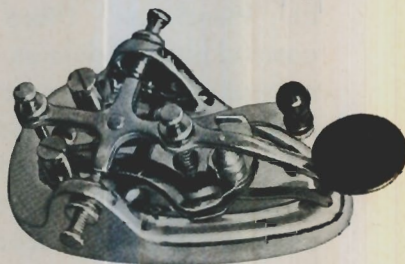

No. 300
at **\$2.85** net
No. 200
at **\$1.80** net
No. 100
at **\$1.00** net

Beautiful tear-drop streamlined base with heavy bluish tinging chrome. All parts chromed. Finely balanced key lever. 3/16" contacts, designed expressly for these keys. These pretty Streamkeys have a "feel" that makes good Morse easy for any operator. BB-300, ball bearing balanced lever; BS-300, bronze bearing screws. Same price.

AMATEUR MODEL, SPEED KEY, A-400 @ \$5.95

A genuine commercial or amateur radio operators' speed key of such quality that you'll find it difficult to realize the price is so low.

PROFESSIONAL MODEL, same key but base "black wrinkled." BB-200 or BS-200 same price. AMATEUR MODEL, nearly the same key, that is, using same lever and contacts. Pretty plastic base, cadmium parts. Bronze bearing screws. Stock depleted and deliveries stop January. New S-100, metallized seeper-plastic, at \$1.35 will replace this 100.

AC-DC AUDIO OSCILLATOR



MODEL No. A-700 **\$2.85**
Net to Operator
Minus Tube
Uses 117N7GT

An oscillator fully as good as my amazingly good Oscillatone, except smaller housing because no speaker. Electronically keyed which means limitless speed and clean keying. Uses 110 to 120 volts, either AC or DC. Connect jumper wire across two rear terminals for speaker volume. Terminals: 2 right for key; 2 left for headphones.

Battery Powered AUDIO OSCILLATOR

MODEL No. B-700 **\$1.80**
Net to Operator
Minus Tube and Batteries
Uses 1Q5GT



Same pretty plastic cabinet as Model A-700. A remarkably good audio oscillator giving a beautiful clear 1000 cycle note. Uses 1 1/2 volt for A battery and 2 1/2 volts or 45 volts B battery depending upon volume desired. Terminals: 2 right for key; 2 left for phones or speaker. Rear terminals, left to right: B plus, B minus; A plus, A minus.

Same pretty plastic cabinet as Model A-700. A remarkably good audio oscillator giving a beautiful clear 1000 cycle note. Uses 1 1/2 volt for A battery and 2 1/2 volts or 45 volts B battery depending upon volume desired. Terminals: 2 right for key; 2 left for phones or speaker. Rear terminals, left to right: B plus, B minus; A plus, A minus.

T.R. McElroy



100 BROOKLINE AVENUE

BOSTON, MASS.

¡Queridos Señores!

"THE RADIO AMATEUR'S HANDBOOK" se puede ahora conseguir en lengua española traducido por la Revista Telegráfica de Buenos Aires, Argentina, reconocida como la más antigua establecida y la más importante publicación de literatura de Radio en Sudamérica.

El "Handbook" (libro manual) está reconocido como el libro modelo en su clase. El por tanto tiempo esperado y sugestionado libro manual (Handbook) estamos seguros que su edición en español encontrará una acogida extraordinaria. Ha sido cuidadosa y escrupulosamente traducido. Ha sido impreso en una imprenta que está reconocida como la mejor de Sudamérica.

Nosotros estamos orgullosos del hecho que la Revista Telegráfica haya producido este trabajo y estamos seguros al mismo tiempo que es una contribución notable para la literatura técnica en la lengua española.

Se pueden conseguir ejemplares en "The American Radio Relay League, West Hartford, Connecticut, U. S. A." a \$1.50 cada ejemplar, franco, o si es más conveniente directamente de la Revista Telegráfica, Perú 165, Buenos Aires, Argentina, a cinco pesos, en moneda argentina.

AMERICAN RADIO RELAY LEAGUE

BIRNBACH for CABLES-WIRE-CERAMICS



TRANSMISSION CABLES



Genuine E01 Cable will handle up to 1 KW. 2 No. 12 Conductors 72 ohms surge impedance with weatherproof braid overall with mica finish.



72 ohms impedance. No. 14 solid conductors with rubber jacket and weatherproof braid overall. The finest twisted pair transmission cable made for ultra high frequency work.



72 ohm all rubber weatherproof. 2 No. 16 stranded for F-M and Television Receiver and Master Antenna Systems.

MULTI CONDUCTOR CABLES



Rubber Jacketed Crystal microphone cable having low losses available in 3 sizes, .270 dia. and lapol types in .175 and .150 dia.



Shielded Rubber Microphone Cable available from 2 to 7 conductors. Unshielded from 2 to 6 conductors. All have a tough Rubber Jacket Overall.



Battery cable in 2 to 10 conductor available in 3 types. Cotton braid, shielded overall and cotton braid over shield.



Diathermy cable available in heavy and light duty together with plugs and jacks for complete assembly.

FM AND TELEVISION ANTENNAS

(ADJUSTABLE)



The elements consist of corrosion proof aluminum alloy tubes ADJUSTABLE to all frequencies between 80 mcs. and 40 mcs. mounted on high grade low absorption glazed porcelain standoff insulators which maintains its efficiency under all weather conditions. Light but rugged construction meets by the strong wooden supports. Complete with mounting poles and stool coupling.



No.	List Price
140—Doublet	\$ 9.00
142—Doublet with reflector	17.00

PORTABLE DOUBLET

(FOR TELEVISION OR FM)



An adjustable antenna that can be rotated to any degree of polarization. Aluminum alloy tubing permits outdoor mountings. Special tapered lock bushings hold each section in place simply by turning and pushing down.

No.	List Price	Frequency Range in Mcs.	
		Open	Telescoped
150.....	\$3.75	82	155
160.....	\$4.25	40	75

CERAMIC INSULATORS

FEED THRU INSULATORS

STANDOFF INSULATORS

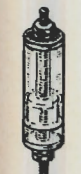

LUCITE FEEDTHRU



CORRUGATED FEEDTHRU



FEEDTHRU



STEATITE BUTTON



METAL BASE



STEATITE PILLAR



STANDOFF



CONE

A large selection of types of feed thru insulators with heights from 3/8" to 4 1/2" plain end with jack tops in addition to the many recently added. Glazed low absorption Porcelain, Steatite and Lucite gives choice of insulation for every application. All come complete with Brass NP hardware.

Every accepted type of standoff insulator in a range of heights from 3/8" to 4 1/2" plain and with jack tops. Highly vitrified low absorption glazed porcelain and Steatite insulator available with brass nickel plated hardware.

SEE YOUR DEALER FOR A COPY OF OUR 1941 CATALOG

Antenna Insulators, Spreaders, Antenna wire, Sockets, Hardware, Test Leads, Jacks and Plugs, Hook up wire, and numerous other items are listed.

BIRNBACH RADIO CO., Inc.

145 HUDSON STREET, NEW YORK, U.S.A.

Prepare for

NATIONAL DEFENSE

*Although Our Part Is Very Small We Will Do
It as Though the Entire Program
Depended Upon Us!*

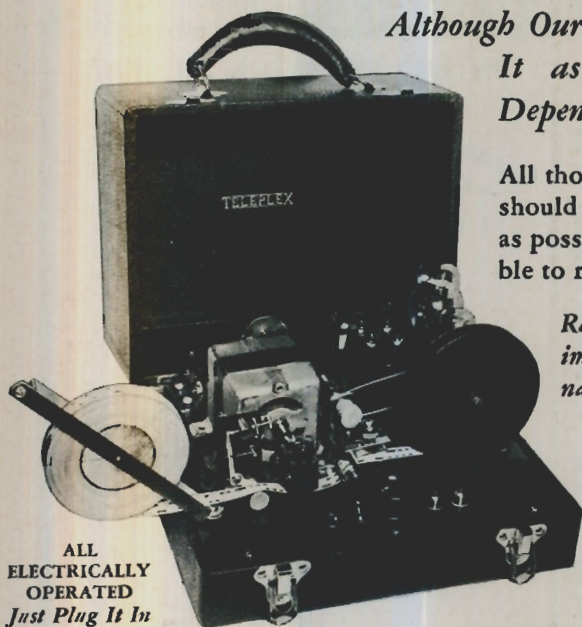

ALL
ELECTRICALLY
OPERATED
Just Plug It In

All those of the selective draft age should prepare themselves as much as possible and as quickly as possible to render technical service.

Radio telegraphy rates high in importance in every phase of national security.

MASTER THE CODE
with
MASTER TELEPLEX

→ → →
THIS TAPE was made on **MASTER TELEPLEX** by "Bug" sending
YOU CAN'T GO WRONG WHEN YOU CAN SEE WHAT YOU ARE DOING!

→ → →
THERE IS ONLY ONE WAY TO LEARN TO RECEIVE THE CODE SIGNALS AND THAT IS BY LISTENING TO THE SIGNALS. THERE IS ONLY ONE WAY TO LEARN TO SEND THE SIGNALS PROPERLY AND THAT IS BY BEING ABLE TO SEE AND HEAR YOUR OWN SIGNALS.

WITH MASTER TELEPLEX YOU LEARN THE CODE IN THE NATURAL, EASY, FASCINATING WAY. THERE IS NO GUESSWORK BECAUSE YOU ACTUALLY SEE AND HEAR WHAT YOU ARE DOING!

Learning to send PROPERLY is more difficult than learning to receive. Most people think sending is easy. Well, just ask the fellow who tries to receive it! How do you make the letter "C"? Of course not like the third one shown below. But you might be surprised! Actually; most professional operators are astounded to see their sending recorded on MASTER TELEPLEX.

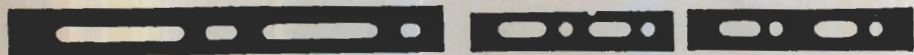

MASTER TELEPLEX will show you exactly how you make the letter "C" and all the rest of the characters. And it will show you how to make them correctly!

CATALOGUE QB EXPLAINS FULLY THE MANY INTERESTING AND FASCINATING FEATURES OF MASTER TELEPLEX. It also lists three other types of Code Teachers. Just send a post card asking for catalogue QB. No obligation.

TELEPLEX CO.

67-69 Park Place
New York City

In Canada Write CANADIAN ELECTRONIC INST., TORONTO, ONT.



RAYTHEON *Makes them All!*



FOR REMOTE CONTROL

RK-34.....\$3.50
RK-62.....\$3.50

A transmitter using one RK-34 will operate an RK-62 receiver over considerable distances for control of model airplanes, boats, etc.

HIGH POWER — HIGH FREQUENCY

RK-63	RK-65
Triode	Tetrode
\$22.00	\$34.50

Tantalum elements, heavy filaments, long life. Over 500 watts from either type with only 6 watts drive for the RK-65.

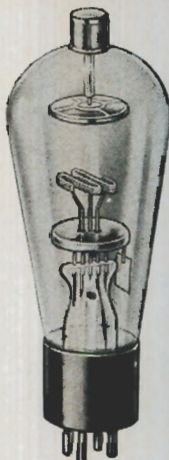
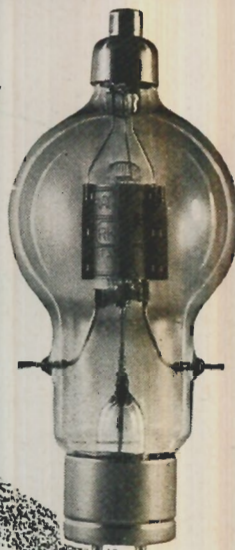

GENERAL PURPOSE RECTIFIERS

RK-60.....\$2.75
866.....\$1.50

866 now carries 10,000 volts rating! For many lower power requirements use high vacuum type RK-60.



HEARING AID TYPES

CK-501 Voltage Amplifier.....\$3.00
CK-502 Crystal Phone Output..... 3.00
CK-503 Magnetic Phone Output... 3.00
CK-504 Crystal Phone Output..... 3.00
CK-505 Voltage Amplifier..... 3.00

FOR MOBILE USE

RK-39.....\$3.50
RK-59*..... 4.50
RK-64*..... 3.50
RK-66*..... 3.50

For practically all mobile requirements, combinations of the quick heating types RK-59, RK-64 and RK-66 (filament equivalent of RK-39) will be found most efficient.

For general purpose, low power applications, the RK-39 is unbeatable.
* Instant Heating

TYPE	Power Output*	Amateur Net	TYPE	Power Output*	Amateur Net
RK-20A	84	\$15.00	RK-56	12.5	\$3.00
RK-23	22	4.50	RK-57/80S	215	13.50
RK-25	22	3.95	RK-59	32	4.50
RK-28A	250	28.50	RK-60	600v-250ma.	2.75
RK-34	16	3.50	RK-62		3.50
RK-38	225	13.50	RK-63	525	22.00
RK-39	36	3.50	RK-64	10	3.50
RK-41	36	3.50	RK-65	510	34.50
RK-47	120	17.50	RK-66	40	3.50
RK-48A	250	27.50	866	Mercury	1.50
RK-49	25	1.25	866A	Vapor	2.50
RK-51	170	6.95	873A	Rectifiers	11.00
RK-52	135	6.95			

* C.C.S. (Continuous Commercial Service Rating.)

CHICAGO
ATLANTA
NEWTON, MASS

RAYTHEON RK

NEW YORK
SAN FRANCISCO

Quality above all



TRANSMITTING CAPACITORS



SOLAREX — Super-value for Filters



TRANSOIL — for Permanent Filters

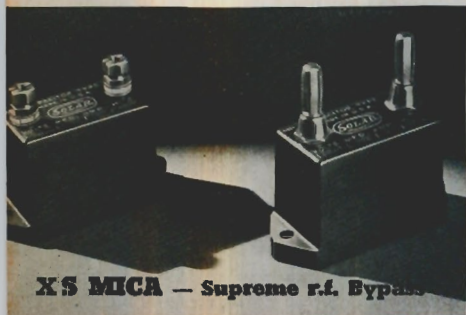

XS MICA — Supreme r.f. Bypass



TRANSMICA — Current-carrying; High Q

SOLAR MFG. CORP. • Bayonne, New Jersey

XM MICA — High Voltage & Stability



Catalog Sent on Request



9X

TURNER

MICROPHONES

EACH SCIENTIFICALLY DESIGNED,
BEAUTIFULLY STYLED AND
ENGINEERED FOR YOUR BETTER
PERFORMANCE AND DEPENDABILITY



VT-73

Also Many Other Models You'll Like--Ask for Catalog

Sweeten up your rig with a Turner Mike — the choice of discriminating buyers who want the most for their money! Professional in performance and appearance, Turner Mikes are demanded by those who know, for all commercial and amateur purposes.

99 DYNAMIC The most rugged mike we offer. Was chosen official mike at W6USA California Exposition. Professional gunmetal finish. 200, 500 ohms or hi-impedance, List..... \$29.50

***44X CRYSTAL** Allows you to choose the sound you want to amplify. The 13-15 DB differential between front and rear pick-up permits mike to be considered dead at rear, eliminating background disturbances. Satin-chrome finish. With 7 foot removable cable set, List..... \$26.00

***22X CRYSTAL** A beautiful eyeful. Streamlined satin chrome model, with 90° tilting head and fully protected crystal. Exceptionally free from feedback. With 7 foot removable cable set, List..... \$16.50

***22D DYNAMIC** Same appearance as 22X, but more rugged, List, \$20.00

9X CRYSTAL HAN-D, Double throat mike that does two jobs at one low cost. Use as a lightweight, rugged hand mike, hang with the suspension hook or mount on desk or floor stand. Equally good for voice or music. Rich brushed chrome finish. Built-in off-on switch works every time without thumb fatigue. Use outside for belly-hoo, inside for fine work. With 7 foot cable set, List..... \$22.50

9D DYNAMIC HAN-D Same appearance as 9X, but more sturdy. 200-250 ohms, 500 ohms, or hi-impedance, with 7 foot cable set, List, \$25.00

BX CRYSTAL CHALLENGER A honey for recording, P. A. or amateur work. Bronze enamel finish. The utmost in quality and appearance at lowest cost. With 7 foot cable, List..... \$9.95

BD DYNAMIC CHALLENGER Works indoors or out. 200-250 ohms, 500 ohms or hi-impedance, List..... \$12.50

MODEL VT-73 Doubles your effective power at the intelligible voice frequencies without over-modulation. Speech frequencies emphasized by rising curvature of response between 500 and 4000 cycles. Finished in telephone black, polished aluminum and crystal. Mike, stand and cable, List..... \$18.00

***33X CRYSTAL** Our finest crystal mike, with semi- or non-directional operation. Full tilting head, satin chrome finish. High capacity crystal permits long lines to be run without frequency discrimination. Complete with 7 foot removable cable set, List..... \$21.00

33D DYNAMIC Same appearance as 33X, with 7 foot removable cable set, ruggedly constructed to withstand hard usage. 200 ohms, 500 ohms or hi-impedance, List..... \$23.50

All Turner Models Listing at \$16.50 and Up Packed
with Chamoisette Mike Pouch to Protect Their Beauty
For 25 Ft. Cable Set with Any Model, Add \$1.50 List

THE TURNER CO. CEDAR RAPIDS, IOWA

*Available with Off-On Switch which quietly shorts the line and converts into "push-to-talk" unit, at additional \$2.00 List

Write TODAY for FREE Information
on Any Models — Use the Coupon



44X



99



9D

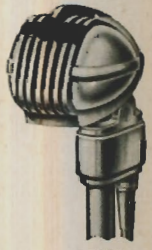

33D



22X



CD

FILL AND MAIL

The TURNER CO.
Dept. AH

CEDAR RAPIDS, IOWA

Please send me Free Details
on Models.....

Name.....

Address.....

City.....

State.....

Crystals Licensed Under Patents of
The Brush Development Co.

ELECTRICAL
MEASURING
INSTRUMENTS

TRIPLET

A NEW
CONCEPTION
OF QUALITY



Model 327-A

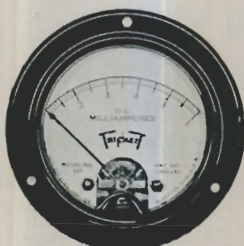

Model 321



Model 529



Model 446

IN TRIPLET'S complete line of instruments, you can always find the answer to your amateur station and experimental electrical measurement requirements. Panel instruments and portable types are available in more than 26 case styles — round, square and fan. Panel instrument sizes are from 2" to 7" inclusive; with rear or front illumination optional. Included in the line are Voltmeters, Ammeters, Milliammeters, Millivoltmeters, Microammeters, R Meters, Thermo Ammeters, Decibel Meters, Volume Unit Meters, Electrodynamicometer type instruments and Instrument Relays.

Each Triplet instrument has two genuine sapphire jewel bearings and incorporates every refinement marking the most approved instrument building practice. D.C. instruments are the D'Arsonval type with an extra light moving coil; magnets with pole pieces aligned to permanent precision accuracy; trussed metal bar bridges. A.C. instruments are the movable double iron repulsion type, with interchangeable coils.

A Few Typical Bargains

Models 341 (3" round), 327-A (3" square) Thermo Ammeters — Ranges 0-.5, 0-1, 0-1.5, 0-2.5 and 0-5 Amps. — with internal couples . . . **\$4.50** net each

Models 321 (3" round), 327-A (3" square) D.C. Voltmeters, 1000 ohms per volt. Provided with special external metallized multipliers on bakelite strip. Ranges — 0-1000; 0-1500; 0-2000; 0-2500; 0-3000 and 0-4000 **\$8.67** net each

Models 321 (3" round) and 327-A (3" square) Decibel Meter. Standard range, up 6, down 10. **\$7.84** net each

(All prices are U. S. A. Amateur's Net)

Vacuum Tube Voltmeters and a complete line of radio test equipment also are available. Write for literature

DESIGNED FOR YOUR REQUIREMENTS



THIS handy pocket-size Volt-Ohm-Milliammeter is a "must" item for every ham shack. Has A.C.-D.C. voltage ranges to 5000 Volts, self-contained, and complete facilities for Direct Current and Resistance analyses. A.C. and D.C. Volts at 1000 Ohms per Volt 0-10-50-250-1000-5000 (compensated copper-oxide rectifier provides for A.C. measurements); D.C. Milliamperes 0-10-100-500; Resistance 0-300 Ohms, shunt type circuit; 10 Ohms reading at center scale; 0-250,000 Ohms, series type circuit. Higher resistance measurements are available by using external batteries. Selector switch for all instrument readings. Hand set for resistance adjustment; no need to use screwdriver. Model 666-H has black molded case and panel, completely insulated. Net Price **\$14.50**

Get Peak Efficiency with a Modulation Monitor

You've solved your problem of getting maximum efficiency from your transmitter when you invest in a Triplet Modulation Monitor. Triplet engineers, working closely with radio amateurs, have developed this monitor exactly as you want it — to fill your needs and fit your pocketbook.

And . . . better yet . . . it saves you money by increasing your range without the added expense of remodeling your transmitter. (Amateur experience has shown that a properly modulated 10-watt rig can be as efficient as a 50% modulated 40-watt transmitter.)

Write for technical details

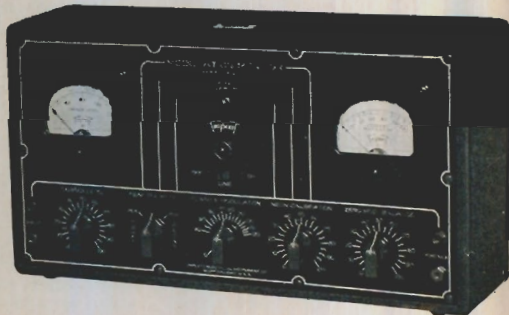

THE TRIPLET ELECTRICAL INSTRUMENT COMPANY
1000 HARMON DRIVE
BLUFFTON, OHIO, U. S. A.



In keeping with its policy of providing all services within its power, The American Radio Relay League makes available to amateurs and would-be amateurs literature properly prepared to present in the best form all available information pertaining to amateur radio. The fact that its offices are the national and international headquarters of radio amateurs, makes League publications authoritative, complete, up-to-the-minute; written from a thoroughly practical amateur's point-of-view. These publications are frequently revised and augmented to keep abreast of the fast-changing field. All are printed in the familiar QST format which permits thorough but economical presentation of the information. Various invaluable printed forms, designed to facilitate compliance with the rules of good amateur practice, are available at moderate cost. We maintain to the best of our ability a stock of back copies of QST which are available at the original single-copy price. Most of the publications and supplies described in the following pages are handled by your dealer for your convenience.

THE AMERICAN RADIO RELAY LEAGUE, INC.
WEST HARTFORD, CONNECTICUT



For twenty-six years (and thereby the oldest American radio magazine) *QST* has been the "bible" of Amateur Radio.

QST faithfully and adequately reports each month the rapid development which makes Amateur Radio so intriguing. Edited in the sole interests of the members of The American Radio Relay League, who are its owners, *QST* treats of equipment and practices and construction and design, and the romance which is part of Amateur Radio, in a direct and analytical style which has made *QST* famous all over the world. It is essential to the well-being of any radio amateur. *QST* goes to every member of The American Radio Relay League and membership costs \$2.50 per year in the United States and Possessions. All other countries \$3.00 per year. Elsewhere in this book will be found an application blank for A.R.R.L. membership.

The OFFICIAL
MAGAZINE *of the*
AMERICAN RADIO
RELAY LEAGUE



QST

Yearly Binders

Those who take pride in the appearance of their lay-out and wish to keep their reference file of QST's in a presentable manner, appreciate the QST binder. It is stiff-covered, finished in beautiful and practical maroon fabrikoid. Cleverly designed to take each issue as received and hold it firmly without mutilation, it permits removal of any desired issue without disturbing the rest of the file. It accommodates 12 copies of QST and the yearly index. Opens flat at any page of any issue.

With each Binder is furnished a sheet of gold and black gummed labels for years 1922 through 1941. The proper one can be cut from the sheet and pasted in the space provided for it on the back of the binder.

The back covers of QST contain the record of development of modern amateur technique. They are invaluable as technical references. Our supply of most issues is already exhausted, but many since 1925 are still available.

A file of several years of QST, kept in order in binders, is a most valuable reference library for any Radio Amateur.

1934 to 1940 copies, inclusive, complete, \$2.50 per yearly set.

1925 to 1933 copies, inclusive, incomplete. Available copies of these years furnished upon application.

All single copies, 25c each. Foreign add 50c for each twelve copies ordered.



Price

\$1.50
POSTPAID

Available only in United States and Possessions

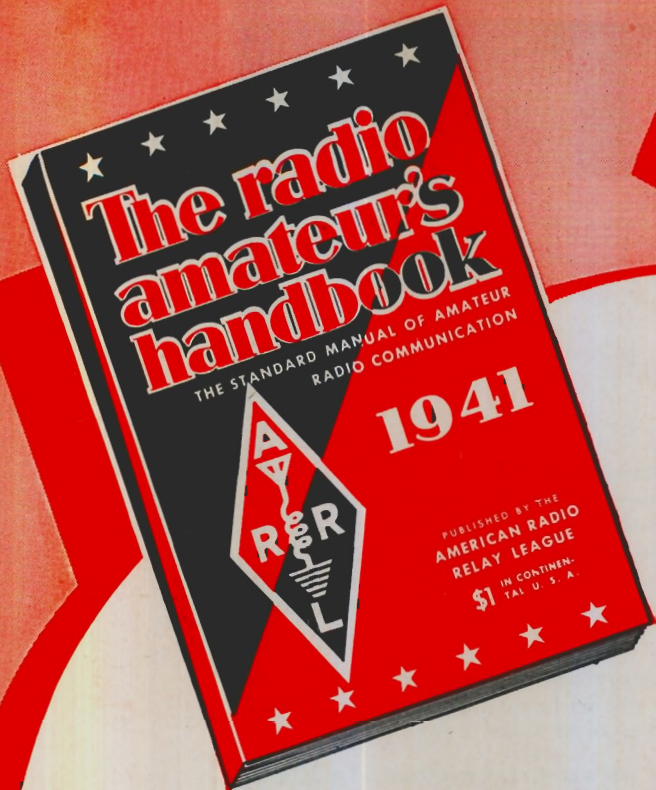

\$1 POSTPAID
\$1.50 OUTSIDE
CONTINENTAL
U. S. A.

BUCKRAM BOUND
\$2.50 POSTPAID
SPANISH EDITION
\$1.50 POSTPAID

The Handbook tells the things which are needed for a comprehensive understanding of Amateur Radio. From the story of how Amateur Radio started through an outline of its wide scope of the present — from suggestions on how to learn the code through explanations of traffic-handling procedure and good operating practices — from electrical and radio fundamentals through the design, construction, and operation of amateur equipment — this book covers the subject thoroughly. It includes the latest and the best information on everything in Amateur Radio.

Universally recognized as the standard elementary guide for the prospective amateur, *How to Become a Radio Amateur*, features equipment which, although simple in construction, conforms in every detail to present practices. The apparatus is of a thoroughly practical type capable of giving long and satisfactory service — while at the same time it can be built at a minimum of expense. The design is such that a high degree of flexibility is secured, making the various units fit into the more elaborate station layouts which inevitably result as the amateur progresses. Complete operating instructions and references to sources of detailed information on licensing procedure are given, as well as a highly absorbing narrative account of just what amateur radio is and does.

25c

POSTPAID
ANYWHERE

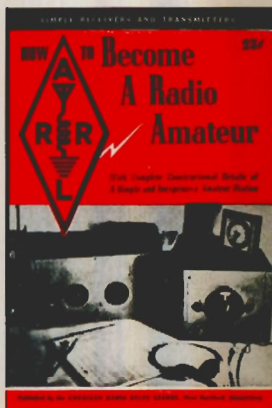

Amateurs are noted for their ingenuity in overcoming by clever means the minor and major obstacles they meet in their pursuit of their chosen hobby. An amateur must be resourceful and a good tinkerer. He must be able to make a small amount of money do a great deal for him. He must frequently be able to utilize the contents of the junk box rather than buy new equipment. Hints and Kinks is a compilation of hundreds of good ideas which amateurs have found helpful. It will return its cost many times in money savings — and it will save hours of time.

50c

POSTPAID
ANYWHERE

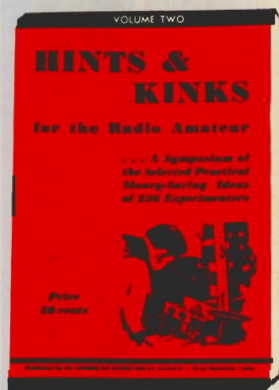

A comprehensive manual of amateur antenna design and construction, by the headquarters staff of the American Radio Relay League. Eighteen chapters, profusely illustrated. Both the theory and the practice of all types of antennas used by the amateur, from simple doublets to multi-element rotaries, including long wires, rhomboids, vees, phased systems, u.h.f. systems, etc. Feed systems and their adjustment. Construction of masts, lines and rotating mechanisms. The most comprehensive and reliable information ever published on the subject.

50c

POSTPAID
ANYWHERE

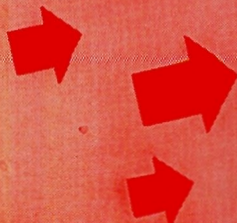
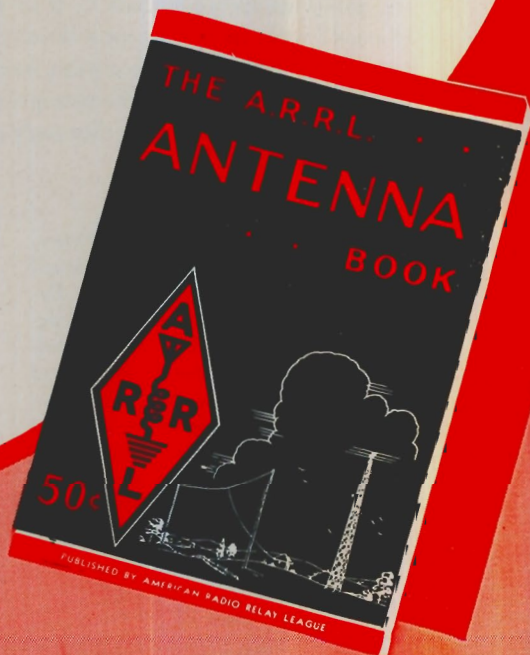

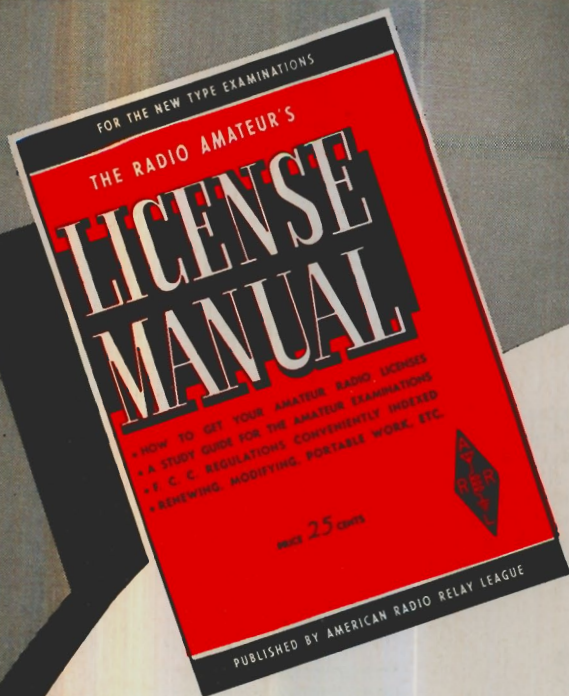

25¢

postpaid
anywhere

Before you can operate an amateur transmitter, you must have a government license and an officially assigned call. These cost nothing — but you must be able to pass the examination. The examinations are based on the multiple-choice type of questions. The "License Manual" has been written to make it as easy as possible for the individual to acquire the necessary knowledge to pass the examination with flying colors. Whether you are going up for your Class C, B or your Class A ticket, "The License Manual" will provide the most direct path to getting that ticket. If you are one of the thousands who always wants a "License Manual" around the shack for ready reference for amateur regulations, it will please you to know that the regulations are very thoroughly indexed.

An introduction into Amateur Radio-telephony. Written for the man who has a class C or class B license. A companion book to "How to Become a Radio Amateur." Contains simple description of the process of modulation and principles of good design for 'phone. Description of inexpensive low power transmitter and modulator, with complete operating instructions plus some antenna dope of particular interest in 160- and 10-meter operation. It tells what a new or inexperienced ham should know before attempting to use 'phone.

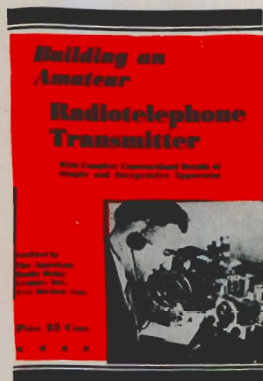

25¢

postpaid
anywhere

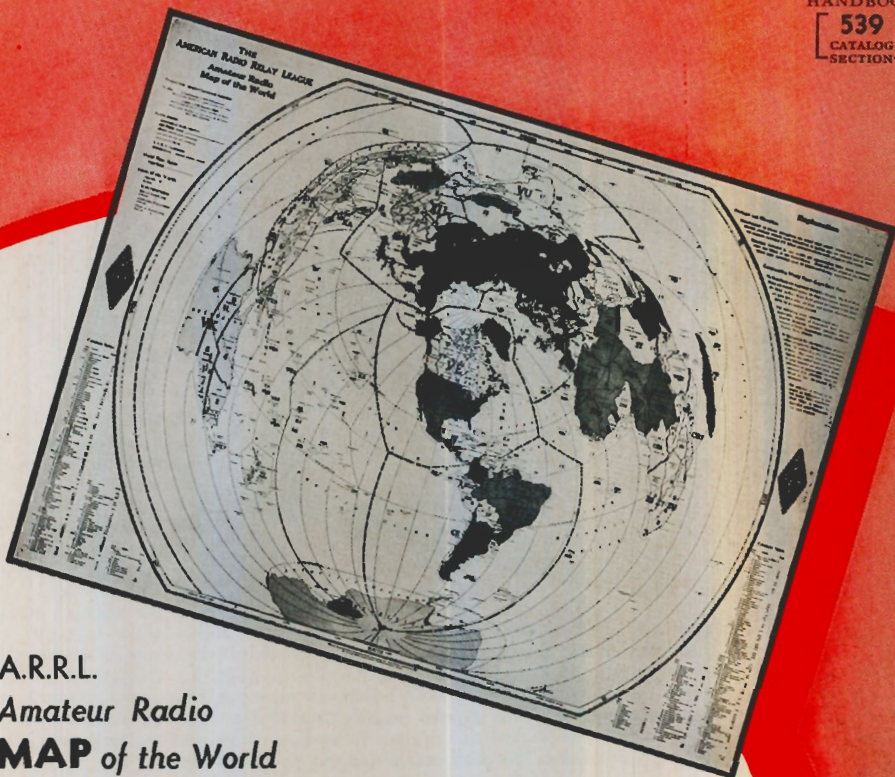

A.R.R.L.
Amateur Radio
MAP of the World

A map entirely new in conception and design, contains every bit of information useful to the radio amateur. A special type of projection made by Rand, McNally to A.R.R.L. specifications. It gives great circle distance measurements in miles or kilometers within an accuracy of 2%. Shows all principal cities of the world; local time zones and Greenwich; WAC divisions; 230 countries, indexed; 180 prefixes, districts and subdivisions, where used; and U. S. examining points. Large enough to be usable, printed in six colors on heavy map paper, 30 x 40 inches.

\$1.25
POSTPAID

TWO HUNDRED METERS AND DOWN

The Story of Amateur Radio
by CLINTON B. DESOTO

A detailed, accurate presentation in full book length of all the elements that have served to develop the most unique institution of its kind in the history of the world. A book of history but not a history-book, **TWO HUNDRED METERS AND DOWN: The Story of Amateur Radio** tells in spirited, dramatic fashion the entire chain of significant events in the development of the art.

Approximately 200 pages, 90,000 words, with durable imitation leather red paper cover

\$1.00
POSTPAID

Deluxe edition bound in blue cloth

\$2.00
POSTPAID

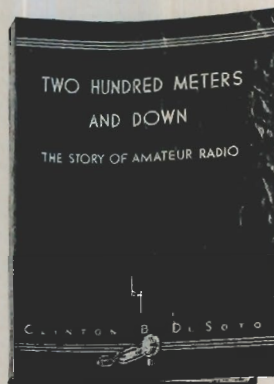

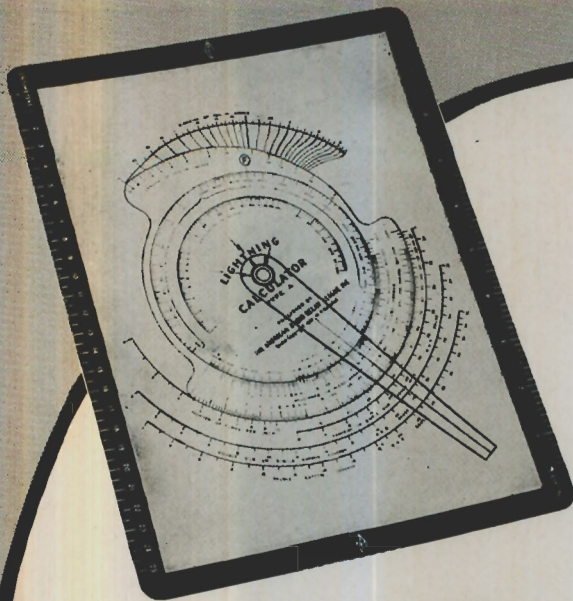

Lightning

arise in all kinds of radio and allied work. They make it possible to read direct answers without struggling with formulas and computations. They are tremendous time-savers for amateurs, engineers, servicemen and experimenters. Their accuracy is more than adequate for the solution of practical problems, and is well within the limits of measurement by ordinary means. Each calculator has on its reverse side detailed instructions for its use; the greatest mathematical ability required is that of dividing or multiplying simple numbers. All calculators are printed in several colors and are wrapped in cellophane. You will find lightning calculators the most useful gadgets you ever owned.

RADIO CALCULATOR

Type A

This calculator is useful for the problems that confront the amateur every time he builds a new rig or rebuilds an old one or winds a coil or designs a circuit. It has two scales for physical dimensions of coils from one-half inch to five and one-half inches in diameter and from one-quarter to ten inches in length; a frequency scale from 400 kilocycles through 150 megacycles; a wavelength scale from two to 600 meters; a capacity scale from 3 to 1,000 micro-microfarads; two inductance scales with a range of from one microhenry through 1,500; a turns-per-inch scale to cover enameled or single silk covered wire from 12 to 35 gauge, double silk or cotton covered from 0 to 36 and double cotton covered from 2 to 36. Using these scales in the simple manner outlined in the instructions on the back of the calculator, it is possible to solve problems involving frequency in kilocycles, wavelength in meters, inductance in microhenrys and capacity in microfarads, for practically all problems that the amateur will have in designing — from high-powered transmitters down to simple receivers. Gives the direct reading answers for these problems with accuracy well within the tolerances of practical construction.

\$1.00 POSTPAID

OHM'S LAW CALCULATOR

Type B

This calculator has four scales:

A power scale from 10 microwatts through 10 kilowatts.

A resistance scale from .01 ohms through 100 megohms.

A current scale from 1 microampere through 100 amperes.

A voltage scale from 10 microvolts through 10 kilovolts.

With this concentrated collection of scale, calculations may be made involving voltage, current, and resistance, and can be made with a single setting of a dial. The power or voltage or current or resistance in any circuit can be found easily if any two are known. This is a newly-designed Type B Calculator which is more accurate and simpler to use than the justly-famous original model. It will be found useful for many calculations which must be made frequently but which are often confusing if done by ordinary methods. All answers will be accurate within the tolerances of commercial equipment.

\$1.00 POSTPAID

Engineering Calculators

WIRE DATA CALCULATOR

Type C

Makes instantly available information on electrical conductors which would require hours of work and access to many textbooks. It has scales for dia. in mills, Stubbs and B&S wire gauges, current carrying capacity in milliamps, turns-per-inch and turns-per-centimeter for all kinds of insulated and bare wire, and a current-carrying-capacity scale for weatherproof and rubber-insulated wire. It gives turns per sq. in., ft. per lb., ohms per mi., ohms per km., ohms per 1000', volts lost per 1000' per amp., current carrying capacity at 1500 cm. per amp., lbs. per 1000', lbs. per mi., approximate tensile strength, ft. and meters per ohm, circular mills, equivalent in sq. wire. Nichrome, manganin, nickel, brass, aluminum, copper and silver wires are covered by these scales.

50c POSTPAID

RESISTANCE CALCULATOR

Type F

This calculator makes an ohmmeter of your voltmeter. With it, it is possible to measure the resistance of a resistor or circuit by using any voltmeter with a known voltage source of from 1 to 300 volts, such as a "B" battery. Has a range from 1 ohm to 1 megohm.

50c POSTPAID

DECIBEL CALCULATOR

Type D

With a scale each for input and output level in current or voltage or power, and a transmission loss or gain scale for either voltage or power ratio plus and minus 120 or 60 db., this calculator may be used in determining decibel gain or loss on four types of problems. When input and output voltages are known, when input and output currents are known, when input and output power are known, or when input voltage to receiver and output level are known. The decibel calculator gives an instant and clear picture of what a decibel is — its relation to power and voltage. Anyone having anything to do with amplifiers, transmission lines, directional antennas, etc., will appreciate this calculator.

50c POSTPAID

PARALLEL RESISTANCE SERIES CAPACITY CALCULATOR

Type E

Solves easily an always confusing problem — the total effective resistance of two or more resistors in parallel, or the total effective capacity of two or more condensers in series. Direct reading answers for condensers or resistors of any size. A simple calculator but very useful.

50c POSTPAID



STATION OPERATING

Supply

AMATEUR RADIO STATION LOG

IF OPERATING AS A PORTABLE OR MOBILE STATION

APPROXIMATE LOCATION

TYPE OF VEHICLE OR MOBILE UNIT IN WHICH INSTALLED

REMARKS, CITY, "HANDLE" CHANGES FROM PREVIOUSLY RECORDED DATA, ETC.

DATE TIME	STATION CALLED	CALLED BY	STATION HEARD OR RECEIVED		IF QSO REPEATED:		TIME OF DAY	MODE	SIGNAL	SPEED	DIRECTION	REMARKS
			R	T	R	T						

LOG BOOK

As can be seen in the illustration, the log page provides space for all facts pertaining to transmission and reception, and is equally as useful for portable or mobile operation as it is for fixed. The 38 log pages with an equal number of blank pages for notes, six pages of general log information (prefixes, etc.) and a sheet of graph paper are spiral bound, permitting the book to be folded back flat at any page, requiring only the page size of 8½ x 11 on the operating table. In addition, a number sheet, with A.R.R.L. Numbered Texts printed on back, for traffic handlers, is included with each book. **35¢ per book or 3 books for \$1**

THE AMERICAN RADIO RELAY LEAGUE
RADIOGRAM

TO: _____

FROM: _____

RECEIVED BY: _____

REMARKS: _____

OFFICIAL RADIOGRAM FORMS

The radiogram blank is designed to comply with the proper order of transmission. All blocks for fill-in are properly spaced for use in typewriter. It has a strikingly-new heading that you will like. Radiogram blanks, 8½ x 7¼, lithographed in green ink, and padded 100 blanks to the pad, **25¢ per pad, postpaid.**

MESSAGE DELIVERY CARDS

Radiogram delivery cards embody the same design as the radiogram blank and are available in two styles — on stamped government postcard, 2c each; unstamped, 1c each.

RADIOGRAM

TO: _____

FROM: _____

RECEIVED BY: _____

REMARKS: _____

The operating supplies shown on this page have been designed by the A.R.R.L. Communications Department.

lies

MEMBERSHIP

STATIONERY

Members' stationery is standard 8½ x 11 bond paper which every member should be proud to use for his radio correspondence. Lithographed on 8½ x 11 heavy bond paper.

100 Sheets, **50c** 250 Sheets, **\$1.00**

500 Sheets, **\$1.75**

POSTPAID

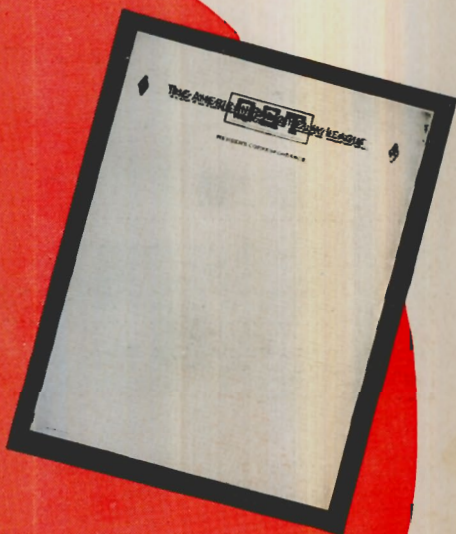

In the January, 1920 issue of *QST* there appeared an editorial requesting suggestions for the design of an A.R.R.L. emblem — a device whereby every amateur could know his brother amateur when they met, an insignia he could wear proudly wherever he went. There was need for such a device. The post-war boom of amateur radio brought thousands of new amateurs on the air, many of whom were neighbors but did not know each other. In the July, 1920 issue the design was announced — the familiar diamond that greets you everywhere in Ham Radio — adopted by the Board of Directors at its annual meeting. It met with universal acceptance and use. For years it has been the unchallenged emblem of amateur radio, found wherever amateurs gathered, a symbol of the traditional greatness of that which we call Amateur Spirit — treasured, revered, idealized.

THE LEAGUE EMBLEM, with both gold border and lettering, and with black enamel background, is available in either pin (with safety clasp) or screw-back button type.

In addition, there are special colors for Communications Department appointees.

- Red enameled background for the SCM.
- Blue enameled background for the ORS or OPS. (Red available in pin type only. Blue may be had in either pin or button style.)

THE EMBLEM CUT: A mounted printing electrotype, 5/8" high, for use by members on amateur printed matter, letterheads, cards, etc.

50c EACH,
POSTPAID



Stationery and Emblems are available only to A.R.R.L. Members.

THE AMATEUR'S BOOKSHELF

A balanced selection of good technical books, additional to the A.R.R.L. publications, should be on every amateur's bookshelf. We have arranged, for the convenience of our readers, to handle through the A.R.R.L. Book Department those works which we believe to be most useful. Make your selection from the following, add to it from time to time and acquire the habit of study for improvement. *Prices quoted include postage.* Please remit with order.

RADIO THEORY AND ENGINEERING

FUNDAMENTALS OF RADIO, by *R. R. Ramsey*. A revision of the author's work which has long been a favorite with amateurs and experimenters. 426 pages, 418 figures, 380 problems. Second edition, 1935.....\$3.50

RADIO ENGINEERING, by *F. E. Terman*. A comprehensive treatment covering all phases of radio communication. An all-around book for students and engineers, 813 pp. 475 illustrations. 2nd Edition, 1937.....\$5.50

ELEMENTS OF RADIO COMMUNICATION, by *Prof. J. H. Mosecroft*. By the author of the well-known "Principles." It is about half the size of the larger work, and the subject is treated in a more elementary fashion. Simple algebra is sufficient. An excellent book for the "first-year" student. 286 pages, 170 illustrations. Second edition, 1934.....\$3.00

PRINCIPLES OF RADIO, by *Keith Henney*. This book is chock-full of meat for the experimenter. The subjects treated range from the fundamentals of electricity to the modern concepts of modulation and detection. 495 pp., 311 illustrations, 3rd Edition, 1938.....\$3.50

COMMUNICATION ENGINEERING, by *W. L. Everitt*. A general text for both first year and advanced courses. Complete treatment of network theory, including mathematical analysis of radio circuits and tube operation. 727 pp., 411 illustrations. 1937.....\$5.00

ENGINEERING ELECTRONICS, by *Donald C. Fink*. Covers the field of electronic tubes and their applications, including not only radio but the other fields into which vacuum-, gas-filled and photo-sensitive tubes are penetrating. Includes theory and design; only relatively simple mathematics required. 358 pages, 217 illustrations, 1938.....\$3.50

FUNDAMENTALS OF RADIO, by *F. E. Terman*. An elementary version of the author's "Radio Engineering," with simplified treatment and intended for readers of limited mathematical ability. Suitable as a text for an introductory course in radio, and features problems for classroom work. 458 pages, 278 illustrations, 1938.....\$3.75

ELECTRICAL ENGINEERS' HANDBOOK, ELECTRIC COMMUNICATION AND ELECTRONICS, by *H. Pender and K. Melvain*. A comprehensive handbook covering the field of communication, both wire and radio, and electronics. 1022 pages, 981 illustrations. Third edition, 1936.....\$5.00

RADIO EXPERIMENTS AND MEASUREMENTS

MEASUREMENTS IN RADIO ENGINEERING, by *F. E. Terman*. A comprehensive engineering discussion of the measurement problems encountered in engineering practice, with emphasis on basic principles rather than on methods in detail. Includes an appendix of outlines for laboratory experiments and a comprehensive index. 400 pages, 208 illustrations. 1935.....\$4.00

THE CATHODE-RAY TUBE AT WORK, by *John F. Rider*. Devoted to cathode-ray tube theory, sweep circuits, a.c. wave patterns and description of commercial oscilloscope units including actual photographs of screen patterns representing about every condition likely to be encountered in audio- and radio-frequency amplifiers, power supplies, complete receivers and transmitters. 322 pages, 444 illustrations.....\$2.50

HIGH-FREQUENCY MEASUREMENTS, by *August Hund*. A thorough, modern book, especially useful in advanced laboratory work. Includes a chapter on piezo-electric determinations. 491 pp., 373 illustrations, 1933.....\$5.00

EXPERIMENTAL RADIO ENGINEERING, by *Prof. J. H. Mosecroft*. An excellent laboratory text directed specifically to emphasizing the principles involved in the operation of radio apparatus and intended as a companion to the same author's "Principles." Following an introductory chapter on instruments and accessories, 51 choice experiments are outlined. 345 pp., 250 illustrations, 1931.....\$3.50

EXPERIMENTAL RADIO, by *Prof. R. R. Ramsey*. A splendid book for the experimenter. This is a laboratory manual, describing 132 experiments designed to bring out the principles of radio theory, instruments and measurements. 196 pages, 167 figures. Fourth edition, 1937.....\$2.75

RADIO FREQUENCY ELECTRICAL MEASUREMENTS, by *Hugh A. Brown*. A laboratory course in r.f. measurements for communications students. Contains much practical information on methods of measurement. 384 pages, 177 illustrations, 2nd edition, 1938.....\$4.00

COMMERCIAL EQUIPMENT AND OPERATING

PRACTICAL RADIO COMMUNICATION, by *A. R. Nilson and J. L. Hornung*. A new modern treatment meeting the expanded scope of technical requirements in the various commercial fields. The first six chapters are devoted to principles, the remaining nine to latest practice in broadcasting, police system, aviation radio and marine communication. Includes an appendix of tabulated data and a complete topical index. 754 pages, 435 illustrations, 1935.....\$5.00

THE RADIO MANUAL, by *George E. Sterling*. An excellent practical handbook, especially valuable to the commercial and broadcast operator, and covering the principles, methods and apparatus of all phases of radio activity. Illustrated. 1120 pages, 1938.....\$6.00

RADIO TRAFFIC MANUAL AND OPERATING REGULATIONS, by *Duncan and Drew*. A book for students, amateurs or radio operators who contemplate entering the commercial field; it will enable you to learn quickly and easily all the government and commercial traffic rules and operating regulations. 187 pp., 1929.....\$2.00

RADIO OPERATING QUESTIONS AND ANSWERS, by *Nilson and Hornung*. Gives the answers to the paraphrase questions in the F.C.C. study guide, including all six elements of the commercial examinations. The old stand-by of the would-be commercial operator, now completely modernized. 415 pages, 87 illustrations, 7th edition, 1940.....\$2.50

RADIO OPERATOR'S MANUAL, by *the Radio Dept., G. E. Co.* Primarily a manual to qualify an applicant for the radiotelephone classes of license (including police), but also provides material of general interest to users of commercial radio equipment. 194 pages, 56 illustrations, 4th edition, 1939.....\$1.00

MISCELLANEOUS

THE RADIO AMATEUR CALL BOOK. Lists all U. S. and foreign amateur radio stations, s.w. commercials and broadcasters. \$1.25 (Foreign \$1.35)

MAKING A LIVING IN RADIO, by *Zeh Bouck*. A worth-while book for the radio amateur who is considering entering the commercial radio field in its many branches; explodes the bunk, points out the pitfalls. 222 pages, 25 illustrations.....\$2.00

RADIO DATA CHARTS, by *R. T. Beatty*. A series of graphic charts for solving, without the use of mathematics, most of the problems involved in receiver design. 82 pp., 8 1/4 x 11.....\$1.50

SERVICING RECEIVERS BY MEANS OF RESISTANCE MEASUREMENTS, by *J. F. Rider*. 203 pp., 91 illustrations. An excellent book for the service man and amateur constructor.....\$1.00

SERVICING SUPERHETERODYNES, by *John F. Rider*. Theory and practice of superheterodynes, with adjustment and troubleshooting data. 278 pages, 94 illustrations.....\$1.00

PRINCIPLES AND PRACTICE OF RADIO SERVICING, by *H. J. Hicks*. A combination of the typical radio textbook dealing with fundamentals and the practical information of the serviceman's manuals. 305 pages, 211 illustrations, 1939.....\$3.00

AUDEL'S NEW RADIOMAN'S GUIDE, by *E. P. Anderson*. For one who wants to get a working knowledge of radio. Not an engineering text, but filled with useful information for the practicing radio man. 765 pages, 519 illustrations, 1940.....\$4.00

AMERICAN RADIO RELAY LEAGUE, INC., WEST HARTFORD, CONNECTICUT

INDEX

	PAGE
A Battery	38
A.A.R.S.	12
ARL Check	435-436
AT-Cut Crystals	75
Abbreviations, Amateur	439-440
Abbreviations, International Standard	437-438
Abbreviations, Radio and Electrical	280
Absorption Frequency Meters	246-247
Alignment, Receiver	133-135
Alternating Current	27-28
Alternator	28
Aluminum	24
Amateur Bands	15-16
Amateur Operator and Station Licenses	20-21
Amateur Regulations	440-446
American Radio Relay League:	
Foundation	10
Headquarters	13-14
Hiram Percy Maxim Memorial	13-14
Joining the League	14
Organization	13, 436
Ampere	24
Ampere Turns	27
Amplification Factor	39
Amplification, Vacuum Tube	39
Amplifier Classifications	42-44
Amplifiers (see "Receivers," "Transmitters" and "Radiotelephony")	
Amplitude Modulation	89
Angle of Radiation	320, 322
Anode	26
Antenna Systems:	
Angle of Radiation	320, 322
Antenna Impedance	321
Bent Antennas	344
Broadside Arrays	348, 349-350
Coaxial Vertical Radiator	416-417
Collinear Arrays	348, 349, 416
Compact Antennas	343-344
Construction of	355
"Corner" Reflector Antennas	417-418
Coupling to Receiver	56-57, 127, 130, 136
Coupling to Transmitter	170-173, 331, 332, 336-337
Directive Antennas	339-341, 348-354, 417-420
Director	352
Driven Elements	348
Dummy Antennas	216, 361
End-Fire Arrays	348, 350
Feed Systems:	
General	325
Characteristic Impedance	326-327
Current	325
Voltage	325
Concentric Lines	325-326, 327, 416-417
Delta Matching Transformer	330-331
Doublet	321
Length	327, 337, 420
Losses	327-328
Linear Transformers	332-333
Multi-Band Antennas	341-344
Non-Resonant Lines	328-329
"Q" Antenna	333
Resonant Lines	333-336
Single-Wire Feed	329
Standing-Wave Ratio	326
Stub Matching	332-333
Tuned Transmission Lines	333-336
Twisted-Pair Feeders	325, 329-330
Untuned Transmission Lines	328-329
Ground Effect	321-322
Grounded Antennas	323-324
Hertz	321
Length	337-338, 340-341, 419-420
Long-Wire Directive Antennas	344-347
Marconi (Grounded) Antennas	323-324
Masts	355-357
Parasitic Elements	355, 351-354
Phased Arrays	351, 417
Polarization	318, 320
Portable	269

	PAGE
Radiation Characteristics	321-323
Radiation Resistance	33, 321
Receiving	360-361
Reflector	352
Rhombic or Diamond Antennas	345-347
Rotary Antennas	357-360
Switching	273-274
Transmission Lines	32-34, 325-326
Tuning	335
Ultra-High Frequency	363, 415-420
V Antennas	344-345
Anti-Nodes	33, 321
Army-Amateur Net	12
Atoms	22
Atmospheric Bending	362-363
Attenuation	318
Audio Frequencies	88
Audio-Frequency Amplifiers	53, 101-103
Audio Limiter Circuits	67-68
Audio Oscillators	17-18, 229, 259
Autodyne Receivers (see "Receivers")	
Automatic Gain Control	63, 64
Auto-Transformer Link Coupling	36
Average Current Value	28
Back-Wave	221
Bakelite	26
B Battery	38
Band Changing	52-53, 87
Band Spread	53
Band Width	48
Bands, Amateur	16-17
Batteries	25, 263-264
Battery Service Hours (Table)	264
Beam Antennas (see "Antenna Systems")	
Beam-Power Tubes	46
Beat Frequency	37, 38
Beat Oscillator	38, 51, 59, 63, 132, 134
Beginner's Code Practice Stations	19
Bench, Work	105
Bending Sheet Metal	107
Bent Antennas	344
Bias	39, 41-42, 84, 184-186, 211-212
Birdies	136
Blanketing	229
Bleeder	174, 178, 179, 187
Blocking	129
Blocking Condensers	71
Body Capacity	130
Brass	24
Break-In	228
Bridge Rectifiers	175
Broadcasting, Interference With	229, 243
Broadside Arrays	348, 349-350
Bus Wire	108
Buzzer Code Practice Set	17
By-Pass Condensers	49, 56, 71
C-L Ratios	32
C. W. Signals	45
Calibrating Frequency Standard	250-251
Canadian General Manager	13
Capacitive Coupling	34
Capacitive Reactance	29, 278
Capacity	23
Capacity of Condenser (Formula)	277
Capacity-Resistance Time Constant	278
Carbon Microphones	88, 100
Carrier	38
Cathode	26, 47
Cathode Bias	41, 42
Cathode Circuits	54-55
Cathode Modulation	93, 98
Cathode-Ray Oscilloscopes	234-239, 259-262
Cathode-Ray Tubes (Table)	301-302
Cell	25
Cement, Coil	108
Century Club	436
Center-Tap	71
Center-Tap Full-Wave Rectifier	175

Index

	PAGE		PAGE
Center-Tap Keying.....	224-225	Condenser Series and Parallel Connections.....	278
Characteristic Curves.....	38, 39-40	Condenser Reactance.....	29
Characteristic Impedance.....	34, 326-327	Condensers, Electrolytic.....	180
Characteristics of Vacuum Tubes (Tables).....	289-317	Condensers, Voltage Rating.....	81, 83
Charges, Electrical.....	22-23	Conductance, Mutual.....	39
Charts and Tables:		Conduction, Electrolytic.....	25
Abbreviations, Amateur.....	439-440	Conduction, Gaseous.....	24-25
Abbreviations for Electrical and Radio Terms.....	280	Conduction, Thermionic.....	25-26
Amateur Wavelength-Frequency Bands.....	16	Conductivity of Metals.....	285
Antenna and Feeder Lengths.....	328, 339, 340, 341, 343, 418, 419	Conductor.....	24
Antenna Gain.....	339, 349, 350, 352	Contests.....	423-424
Battery Service Hours.....	264	Continental Code.....	17
Characteristic Impedance.....	326	Continuous-Wave Signal.....	45
Coil-Winding Data.....	83	Control Circuits.....	271-272
Color Code for Resistors and Condensers.....	279	Control Grid.....	39
Conductivity of Metals.....	285	Controlled-Rectifier Keying.....	222
Continental Code.....	17	Conversion Efficiency.....	59-60
Conversion Factors.....	280	Conversion Factors.....	280
Current Capacity of Power Wiring.....	285	Conversion Factors, Tube (Chart).....	282
Decibel Chart.....	279	Converters, A.C.-D.C.....	266-267
Dielectric Constants.....	277	Converters, Frequency.....	47, 59-60, 122-124
Drill Sizes.....	107	Converters, U.H.F.....	365-372
Dynamotors (Types and Data).....	265	Copper.....	24
Electrical Symbols.....	280-281	Core.....	27
Emergency Rules.....	429	Counting Messages.....	435-436
Gain of Directive Antennas.....	339, 349, 350, 352	Coupled Circuits.....	34
Gas-Driven Generators (Types and Data).....	266	Coupling, Antenna to Receiver.....	56-57, 127, 130, 136
Interference, B. C. L. Frequencies.....	243	Coupling, Antenna to Transmitter 170-173, 331-332, 336-337	49
Message Form.....	430	Coupling Condenser.....	76-77
Metric Prefixes.....	280	Coupling, Interstage.....	135-136
Modulator Data.....	96-97	Coupling, Oscillator.....	72
Prefixes, Amateur.....	440	Creep.....	107
Q Code.....	437-438	Crackle Finish.....	34
R-S-T Scale.....	427	Critical Coupling.....	177-178
Radiation Resistance.....	339	Critical Inductance.....	47
Reactance.....	282	Cross-Modulation.....	64-66
Resistance-Coupled Amplifier Data.....	94-95	Crystal Filters.....	100
Rhombic Antenna Design Charts.....	346	Crystal Microphones.....	73-75, 210-211
Safety Rules.....	187-188, 275-276	Crystal Oscillators.....	(see "Crystal-Controlled Transmitter Construction")
Tank Circuit Capacity.....	81	Crystal-Controlled Transmitter Construction (see "Transmitters" and "Ultra-High Frequencies")	75
Tap Sizes.....	104, 105	Crystals:	
Tools.....	282	Characteristics and Limitations.....	75
Tube Conversion Factors.....	445	Cuts.....	75
U. S. Radio Districts.....	349	Mountings.....	32
V-Antenna Design Chart.....	289-317	Piezo-Electric Effect.....	75
Vacuum Tube Characteristics.....	281-282	Power Limitations.....	75
Vacuum Tube Symbols.....	265	Temperature Effects.....	27
Vibrator Power Supplies (Types and Data).....	283	Current, Alternating.....	285
Wire Table.....	425	Current Capacity of Wires.....	24
Word Lists for Accurate Transmission.....	105-106	Current, Direct.....	325
Chassis Layout.....	431-433	Current Feed for Antennas.....	24
Checking Messages.....	180	Current Flow.....	27
Choke, Filter.....	174, 177-178	Current in A.C. Circuits.....	29
Choke-Input Filter.....	32	Current Lag and Lead.....	39
Choke, R.F.....	21	Cut-Off.....	107
Cipher Groups.....	37	Cutting and Bending Sheet Metal.....	106-107
Circuit Diagrams.....	281	Cutting Threads.....	25
Circuit Diagram Symbols.....	27	Cycle.....	10, 12, 15, 16
Circuit, Electric.....	58	DX.....	436
Circuit Loading.....	57-58	DX Century Club.....	278-279
Circuit Noise.....	56-57	Decibel.....	41
Circuit Values — Receiving.....	30-32	Degeneration.....	435
Circuits, Tuned.....	42-44	Delivering Messages.....	11
Circuits, Receiving (see "Receivers")	98-99, 198-201	Delay.....	330-331
Circuits, Transmitting (see "Transmitters")	96-97	Delta Matching Transformer.....	44
Class A, B, and C Amplifiers.....	107	Demodulation.....	38, 44, 49
Class B Modulation.....	226-228	Detection.....	402
Class B Modulator Data.....	27	Deviation.....	37
Cleaning and Finishing Metal.....	325-326	Diagrams.....	345-347
Clickless Keying Methods.....	416-417	Diamond Antenna.....	26
Closed Circuit.....	16-17, 18-19	Dielectric.....	23
Coaxial Line.....	21	Dielectric Constant.....	277
Code (Continental) and Code Practice.....	17-18	Dielectric Constants (Table).....	106
Code Practice Cipher Groups.....	19	Dies.....	38, 49
Code Practice Sets.....	34	Diode.....	34
Code Practice Stations (for Beginners).....	26-27, 28	Direct Coupling.....	28
Coefficient of Coupling.....	36-37	Direct Current.....	362
Coils.....	108	Direct-Ray Transmission.....	(see "Antenna Systems")
Combined A.C. and D.C.....	13, 436	Directional Antennas.....	352
Coil Cement.....	348, 349, 416	Director.....	13
Communications Department, A.R.R.L.....	36	Directors, A.R.R.L.....	25
Collinear Arrays.....	325-326, 330	Disassociation.....	402
Complex Waves.....	23	Discriminator.....	36, 40
Concentric Transmission Line.....	277	Distortion.....	32
Condenser.....	279-280	Distributed Inductance, Capacitance and Resistance.....	445
Condenser Capacitance (Computing).....	174, 177	Districts, Inspection.....	13
Condenser Color Code.....	100	Divisions, A.R.R.L.....	188-190
Condenser-Input Filter.....	100	Dividers, Voltage.....	71, 85-86, 217
Condenser Microphones.....	100	Double Frequency.....	71, 85-86, 217

Index

	PAGE		PAGE
Double Resonance	217	Input Choke	177
Drill Sizes	107	Linear Matching Sections	332
Drilling Holes	106-107	Modulation Impedance	91
Dry Batteries	25, 263-264	Modulation Percentage	89
Dummy Antennas	216, 361	Multipliers (Meter)	255
Duplex-Diode Triodes and Pentodes	47	Mutual Conductance	39
Dynamic Characteristics	39-40	Ohmmeter (from voltmeter)	256
Dynamotors	266	Ohms Law (A.C.)	30
Dynamotors (Table)	265	Ohms Law (D.C.)	24
E-Layer Transmission	362-363	Overall Gain	101
Effective Current Value	28, 36	Plate Resistance	39
Efficiency, Amplifier	72, 216	Power	26, 216
Electric Charges	22-23	Q	31
Electric Circuit	27	Q Antenna	333
Electric Field	26-27	R/C Time Constant	278
Electrical Interference Reduction	226-231	Reactance	277-278
Electrical Length	32, 327	Regulation	174
Electrical Units and Symbols	280-282	Resonance	30
Electricity	22	Resonant Impedance	31
Electrolytic Condensers	25, 180	Rhombic Antenna	346-347
Electrolytic Conduction	25	Ripple	177
Electromagnetic Radiation	37, 318	Series, Parallel and Series-Parallel Capacities	278
Electromagnetism	26-27	Series, Parallel and Series-Parallel Resistances	24
Electromotive Force (E.M.F.)	23	Sine Curve	28
Electrons	22	Surge Impedance	327
Electron Flow	24	Time Constant	278
Electron-Coupled Oscillator	72-73	Transmission Line Length	327, 333, 351, 420
Electronic Coupled Oscillator	28	Transmission Line Spacing	327
Electrostatic Field	23	Turns Ratio	35
Electrostatic Shielding	219	Voltage Divider	188
Emergency Apparatus (see "Portable Equipment")		Voltage Regulation	174
Emergency Coördinator	12	Wavelength-Frequency Conversion	32
Emergency Corps	12	Wavelength	30
Emergency Operating	427-430	Frequencies, Amateur	15-16
Emergency Work	12	Frequency Converters	28
Emission, Electron	25-26	Frequency Converters	47, 59-60
End-Fire Arrays	348-350	Frequency Measurement:	
Energy Fields	37	100-Kc. Frequency Standard	251-253
Equip-potential Cathode	47	100-1000-Kc. Crystal Oscillator	251
Excitation	42, 72, 82-84, 213-214	100-1000-Kc. E.C. Oscillator	250-251
Exciter Units (see "Transmitters")		Absorption Frequency Meters	246-247
Executive Committee, A.R.R.L.	13	Checking Transmitter Frequency	245-246
Expedition Communications	12-13	Heterodyne Frequency Meters	247-250
Farad	23	Lecher Wires	253-254
Federal Communications Commission, Regulations	440-446	WWV Schedules	262
Feed-Back	44, 137	Frequency Modulation:	
Feedback, R.F.	219-220, 224	Constructional:	
Feeders and Feed Systems (see "Antenna Systems")		Modulator-Oscillator Unit	404-406
Fidelity	40	56-Mc. F. M. Transmitter	406-407
Field, Electrostatic	23	112-Mc. F. M. Transmitter	408-411
Field, Magnetic	26-27	F. M./A. M. I. F. Amplifier	411-413
Fields, Energy	37	General	90, 363
Field-Strength Meters	258	Principles	402-404
Filament	26, 47, 55	Frequency Multipliers	71, 85-86, 217
Filament Supply	183	Frequency Stability	48-49, 60-61, 72, 137, 211
Fills and Repeats	423, 435	Frequency-Wavelength Conversion	32
Filter, Crystal	64-66	Fringe Howl	131
Filters, R.F.	227, 229	Full-Wave Rectifiers	174, 175
Filters (see "Power Supply")		Fundamental Frequency	32, 36
First Detector	59	Gain Control	56, 103
Five Meters (see "Ultra High Frequencies")		Ganged Tuning	37, 87
Fixed Test Messages	434	Gaseous Conduction	24-25
Flow, Current	24	Generators	266
Flywheel Effect	43	Generators, Gas-Driven (Table)	28, 267-268
Force, Electromotive	23	Godley, Paul	10
Force, Lines of	26-27	Government Licenses	20-21
Formulas:		Grid	39
A.C. Average and Effective Values	28	Grid Bias	39, 41-42, 84, 184-186, 211-212
Amplification Factor	39	Grid-Bias Modulation	92, 240-242
Antenna Length	321, 324, 340, 419-420	Grid Condenser	44
Bias Supply Bleeder	184, 185	Grid Detection	44-45, 50-51
Capacitive Reactance	278	Grid Excitation	42, 72, 82-84, 213-214
Capacity of Condenser	277	Grid Keying	223
Cathode Bias	42	Grid Leak	41-42, 44, 50
Coefficient of Coupling	34	Grid Neutralization	75-80, 212-213
Combined A.C. and D.C. Currents	36	Grid-Plate Oscillator	75, 211
Complex Wave	36	Ground Wave	37, 319
Coupling Transformer Turns Ratio	93	Grounds	37, 187
Critical Inductance	177	Grounded Antennas	323-324
Decibel	278	Half-Wave	32
Delta Match	330	Half-Wave Rectifiers	174, 175
Driver Coupling	99	Hard Rubber	26
Filter Design	178-179	Harmonic Distortion	36, 40, 90
Frequency	30	Harmonic Frequencies	33, 36
Grid Leak Bias	42	Harmonic Generation	74, 80
Impedance	30	Harmonic Operation of Antennas	33, 339-344
Impedance Matching	91, 330, 332, 333	Harmonic Resonance	33
Inductance Calculation	277	Harmonic Suppression	218-219
Inductive Reactance	277-278		

Index

	PAGE		PAGE
Headquarters, A.R.R.L.	13	Suppressor Grid	224
Heating Effect	26	Monitors	228
Henry	27	Oscillator Keying	225
Hertz Antenna	321	Parasitic Clicks	227
Heterodyne Reception	45, 51	Safety Rules	276
High-Frequency Oscillator	59, 60-61	(See also "Interference Elimination")	
High-Vacuum Rectifiers	174, 176	Kinescopes (Table)	302
High-Voltage Protection	187-188, 275-276		
Hiram Percy Maxim Memorial	13-14		
Hiss Noise	67, 136	L-C Ratios	32
History of Amateur Radio	9-14	Lag Circuits	226
Holes, Cutting	106	Lag, Current	29
Hook-Up Wire	107-108	Land Line Check	431
How to Become a Radio Amateur (Booklet)	14	Laws Concerning Amateur Operation	440-446
Howl	49	Layer Height	319-320
Hum	130, 137	Laying Out Chassis and Panels	105
		Lead Current	29
Iconoscopes (Table)	317	Lecher Wires	253-254
Image, A.F.	65	License Manual	20-21
Image Ratio	59, 136	Licenses, Amateur	20-21
Impedance	30	Lightning	22
Impedance Matching	34-36	Lightning Protection	276
Impedance, Tank	80-81	Limiter	402
Incident Waves	32	Limiting (Noise) Circuits	67-69
Indicators, Tuning	69-70	Linear Amplifiers	42
Inductance	27	Linear Antenna Transformers	332-333
Inductance Calculation	81, 83, 277	Linear Oscillators	389-393
Induction	27	Linearity	39, 49, 90-91
Inductive Coupling	34	Lines of Force	26-27
Inductive Neutralization	213	Lines, Resonant	33
Inductive Reactance	28-29, 277-278	Link Coupling	35-36, 77, 214
Injection Grid	47	Link Neutralization	213
Input Choke	177-178	Load	27, 40, 80-85, 91, 174, 175, 177-178
Input Condenser	54, 177	Load Impedance	35, 40, 85
Inspection Districts	445	Loading	58, 85, 215-216
Instability	135	Locating the Station	270
Instruments:		Log Books	426-427
Cathode-Ray Oscilloscopes	259-262	Long-Wire Antennas	339-344
Field-Strength Meters	258	Loops	33, 321
Frequency Meters	246-250	Low-Level Modulators	99
Frequency Standards	250-253	Low-Pass Filters	229
I.F. Test Oscillator	258-259	Low-Power Transmitters (see "Transmitters")	
Milliammeters	255-257		
Multi-Range V-O-M	257	Magnetic Field	26-27
Ohmmeters	256-257	Magnetism	26-27
Vacuum-Tube Voltmeters	257-258	Magnetomotive Force	27
Voltmeters	255-257	Manual, License	20-21
Intermediate Frequency	59	Masts	355-357
Intermediate Frequency Amplifiers	62-63	Matched-Impedance Lines	33-34
Intermediate Frequency Test Oscillator	258-259	Matching Impedances	34-36, 91, 98
International Amateur Radio Union	11, 14	Maxim, Hiram Percy	10, 13, 14
Interruption Frequency	46	Maximum Current Value	28
Interstage Coupling	76-77	Measurements (see "Instruments")	
Interstage Transformer	54	Memorizing the Code	16-17
Ionization	27	Mercury Vapor Rectifier	174, 176-177
Ionosphere	328-329	Message Form	415-416
Insulators	26	Metals, Relative Conductivity of	285
Interelectrode Capacitances	44, 46	Metering	87, 206-209
Interference, Elimination of:		Meters (see "Instruments")	
Blanketing	229	Metric Prefixes	280
Broadcasting with	229, 230-231, 243	Mica	26
Electrical Noise Silencing	67-69	Microampere	24
R.F. Filters	227, 229	Microfarad and Micro-microfarad	23
Radiotelephone Interference	226	Microhenry	27
Rectifier Noise	225	Micromhos	39
Superheterodyne Harmonics	224	Microphones	88, 99-101
Wavetraps	224	Milliammeters	255-257
(See also "Keying")		Milliampere	24
Inverse Peak Voltage	174	Millihenry	27
Ions	25	Mixers	47, 59-60
Iron	24	Modulation (see also "Radiotelephony")	88-104
Isolantite	26	Modulation Capability	90, 233
		Modulation Methods	91
Kennelly-Heaviside Layer	319	Modulation Percentage	89
Key, How to Use	19-20	Modulators	191-201
Keyer Tubes	224-225	Molecular Friction	26
Keying:		Molecule	22
Back Wave	221	Monitored Frequencies	428-429
Bias Sources	225	Monitors	228-229, 254-255
Design Considerations	221-222, 227	Monoscopes (Table)	317
Key-Click Elimination	226-228	Motorboating	137
Keyer Tubes	224-225	Mounting Crystals	75
Keying With Break-In	228	Mu	39
Methods:		Multi-Element Tubes	46
Center-Tap	223-224	Multi-Purpose Meter	257
Controlled-Rectifier Keying	222	Multi-Purpose Tubes	47
Grid	223	Multipliers, Frequency	71, 85-86, 217
Plate	222	Mush	136
Primary	222	Mutual Conductance	39
Screen Grid	224	Mutual Inductance	34
		Mycalex	26

Index

	PAGE		PAGE
Naval Communications Reserve (N.C.R.)	12	Potential	23
Negative Charges	22	Power	26
Negative-Peak Overmodulation Indicators	233-234	Power Amplification	41
Neutralization	76-80, 212-213	Power Amplifiers	76
Neutralizing Condensers	80	Power Input	71
Nodes	33, 221	Power Line R.F. Filters	227-228
Noise Ratio	57-58	Power Output	72
Noise Silencing	67-69	Power Sensitivity	46
Non-Linearity	40	Power Supply:	
Nucleus	22	25- and 50-Cycle Supply	178
Numbering Messages	431	A.C.-D.C. Converters	266-267
Ohm	24	Battery Service Hours (Table)	264
Ohm's Law	24	Bias Supplies	184-186
Ohm's Law for A. C.	30	Bleeders	174, 178, 179, 184, 185, 187
Ohmmeters	256-257	Bridge Rectifier	175
Open Circuit	27	Construction	186-188
Open-Wire Line	325	Design	178-180
Operating Notes	421-436	Dry Batteries	263, 264
Operating Position	270-272	Dynamotors	266
Operating Procedure	421-436	Dynamotors (Table)	265
Operator's License	20-21	E.C.O. Exciter Supply	147-149
Originating Traffic	433	Electrolytic Condensers	25, 180
Oscillating Detector	45, 51	Filament Supply	183
Oscillation	44	Filters:	
Oscillation Frequency	44	Design	174, 177-178
Oscillator Coupling (Receivers)	135-136	Filter Chokes	180
Oscillator Keying	225	Filter Condensers	180
Oscillators (see heading covering particular application)		Full-Wave Rectifiers	174, 175
Oscilloscopes	234-239, 259-262	Genemotors	266
Output Condenser	178	Generators	267-268
Output Coupling	85	Generators, Gas-Driven (Table)	266
Output Limiting	103	Half-Wave Rectifiers	174, 175
Output Transformer	54	High-Vacuum Rectifiers	174, 176
Overmodulation	90	Input Choke	177-178
Overmodulation Indicators	233-234	Inverse Peak Voltage	174
Padding Condenser	57	Line Voltage Regulation	190
Panel Layout	105-106	Mercury-Vapor Rectifiers	174, 176-177
Parallel Amplifiers	40	Peak Plate Current	174
Parallel Capacities	278	Portable (see "Portable Equipment")	
Parallel Circuits	24, 71	Portable and Emergency Power Supplies	263-267
Parallel Feed	71	R.F. Filters	227, 229
Parallel Resistances	24	Receiver Power Supplies	190
Parallel Resonance	30-31	Rectifier Circuits	175-176
Parasitic Oscillations	72, 211, 217-218, 227	Rectifier Noise	230
Peak Plate Current	174	Rectifiers	175-177
Peak Current Value	28	Regulation	170, 181-182, 184-186
Pentagrid Converters	47	Ripple	174-175, 177
Pentode Crystal Oscillators	73, 210	Safety Precautions	187-188
Pentodes	46-47	Series Connection of Transformers and Rectifiers	181
Pentode Amplifiers	78	Storage Batteries	263-264
Performance, Receiver	137	Swinging Choke	174, 178
Period	28	Vibrator Supplies (Table)	265
Phase	29-30	Vibrator-Transformers	264-265
Phase Inversion	102	Voltage Dividers	188-190
Phased Antennas	356, 417	Voltage-Regulated Power Supplies	181-183
Phasing Control	65, 131	Windchargers	267
"Phone (see "Radiotelephony")		Wiring, Current Capacity	285
Pi-Section Antenna Couplers	172-173	Prefixes, Amateur	440
Pierce Oscillator	74	Prefixes, Metric	280
Piezo-Electricity	32	Pre-Selection	64, 125-127
Piezo-Electric Crystals (see "Crystals")		Primary	28
Piezo-Electric Microphone	100	Primary Keying	222
Plate	26, 38	Protection from High Voltage	177-178, 275-276
Plate Current	38-39	Pulling	59-60, 129
Plate Detection	44, 51	Pulsating Currents	36
Plate Keying	222	Push-Pull Amplifiers	40-41
Plate Load Resistance	50	Q	31
Plate Modulation	91-92	Q Antennas	333
Plate Neutralization	78	Q Code	437-438
Plate Resistance	35, 39	QRR	429, 438
Platinum	24	QST	10, 13, 14
Polarization	318, 320	Quarter Wave	32
Portable Equipment:		Quartz	26
Antenna Systems	269	Quartz Crystals (see "Crystals")	
Battery Service Hours (Table)	264	Quench Frequency	45-46
Converters, A.C.-D.C.	266-267	R.M.S. Current Value	28
Dry Batteries	263-264	R-S-T System	427
Dynamotors	265, 266	Rack Construction	202-206
Equipment	263	Radiation	37
Genemotors	266	Radiation Angle	320-322
Generators	267-268	Radiation Resistance	33, 321
Power Supply	263-267	Radiator (see "Antennas")	
Receivers	268	Radio Frequency Amplifiers	55, 76
Storage Batteries	263-264	Radio Frequency Choke Coil	32
Transmitters	268-269	Radio Inspection Districts	445
Vibrator-Transformers	264-266	Radiotelephony:	
Windchargers	267	Adjustment	232-233
Positive Charges	22	Amplitude and Power Relations	90-91
Pot Oscillator	387-389	Audio Test Signal Source	259

Index

	PAGE		PAGE
Cathode Modulation	93, 98, 242	Regenerative Pre-Selectors	117-121, 133
Choke-Coupled Plate Modulator	91, 92	Regenerative Receivers, Tuning	128-131
Class-B Audio Operation	42-43, 98-99	Second Detectors	59, 63
Class-B Modulators	98-99, 198-201, 209	Selectivity	48
Class-B Modulator Data	96-97	Sensitivity	48
Construction Practice	191, 209	Servicing Receivers	128, 130-131
Constructional:		Shielding	55-56
3-Watt Speech-Amplifier/Grid Modulator	192-193	Single-Signal Selectivity	132-133
4-Watt Single-Tube Modulator	191-192	Stability	48-49
6.5-Watt Side-Band Limiting and Compression Amplifier	198	Superheterodyne Receivers, Adjustment	131-135
15-Watt 2A3 Speech Amplifier with Negative Feedback	196-197	Test Equipment	128, 255-262
20-Watt Low-Cost 6L6 Speech Amplifier	193-194	Tone Control	54, 137
40-Watt 6L6 Speech Amplifier/Modulator	194-196	Tracking	57, 61-62
Driving Power	93, 98-99, 232	Tuning Indicators	69-70
Driver Coupling	99	Tuning Systems	52-53
Frequencies and Regulations	15-16, 440-446	Ultra-High Frequency (see "Ultra-High Frequencies")	
Frequency Modulation	90	Variable Selectivity	38, 44
Grid-Bias Modulation	92, 239-242	Wiring	38, 49, 174-176
Harmonic Distortion	90	Rectification	38, 49, 174-176
Interference	243	Rectifier-Filter Systems (see "Power Supply")	
Linearity	90-91	Rectifiers (Table)	303-304
Low Level Modulation	98	Reflected Waves	32
Matching	93-94	Reflection of Radio Waves	319-320
Microphones	88, 99-101	Reflector	352
Modulation	88-102	Refraction of Radio Waves	319-320
Modulation Capability	90, 233	Regeneration	45, 66-67, 216
Modulation Methods	91	Regeneration Control	52, 130
Monitors	254-255	Regenerative Detector	45, 51, 52
Oscilloscopic Adjustment	259-262	Regenerative Receivers (see "Receivers")	
Output Limiting	103	Regulation, Voltage	174, 181-182, 184-186
Overmodulation	90	Regulations, Amateur	440-446
Overmodulation Indicators	233-234	Reinartz	11
Percentage Modulation	89	Rejection Control	65
Plate Modulation	91-92	Relay Procedure	433-434
Plate Modulation of Screen-Grid Tubes	91	Remote Control	274
Plate Supply	99	Resistance	22, 24
Power in Speech Waves	90	Resistance-Capacity Time Constant	278
Procedure	425	Resistance-Coupled Amplifier Data	96-97, 101
Resistance-Coupled Amplifier Data	94-95	Resistance, Radiation	33
Side Bands	89-90	Resistances in Series and Parallel	24
Speech Amplifier Design	101-103	Resistive Coupling	34
Suppressor Modulation	92	Resistor Color Code	279
Word List	425	Resonance	30-31
Reactance	28-29	Resonance Curve	48
Reactance, Capacitive	29	Resonant Circuit Impedance	31-32
Reactance Chart	282	Resonant Frequency	30
Reactance, Inductive	28-29	Resonant Line Circuits	33
Reactance Modulator	403	Resonant Transmission Lines	333-336
Receivers:		Rhombic Antenna	345-347
Amplifiers, A.F.	53-54	Ribbon Microphones	100
Amplifiers, R.F.	54-57, 129-130	Ripple	174-175, 177
Antenna Coupling	56-57, 127, 130, 136	Rochelle-Salt Crystals	32
Antenna Tuning Units	127	Root Mean Square Value	28
Antennas for	360-361	Rotary Antennas	357-360
Audio Limiter Circuits	67-69	Rubber, Hard	26
Automatic Gain Control	63, 64	S Meter	69-70
Band Changing	52-53	S Scale	427
Band Spreading	53	Safety Rules	187-188, 206-209, 275-276
Beat Oscillators	38, 51, 59, 63, 124-125	Saturation Point	39
Body Capacity	130	Schematic Symbols	281
Circuit Values	56-57	Schnell	11
Construction:		Screen Grid	46
1-Tube Converter	122-124	Screen-Grid Keying	224
2-Tube Regenerative Receiver	109-113	Seattle, U.S.S.	12
3-Tube Superhet	113-117	Second Detector	59, 63
6-Tube Regenerative Single-Signal Super	117-121	Secondary	28
Beat Oscillator for B.C.L. Sets	125-127	Secondary Emission	26, 46, 217
Frequency Modulation I.F. Amplifier	411-414	Selectivity	31, 48
14- and 28-Mc. Pre-Selector	125-127	Selectivity Control	66
Detector	49-52	Self-Controlled Oscillators	72
Electrical Noise Reduction	67-69	Self-Induction	216-217
Fidelity	49	Self-Oscillation	20
Frequency Converters	47, 59-60, 122-124	Sending	48, 137
Frequency Modulation Reception	402-403, 411-414	Sensitivity	278
Hum	130	Series Capacitors	24, 71
Intermediate Frequency Amplifiers	62-63	Series Circuits	71
Limiting (Noise) Circuits	67-69	Series Feed	24
Noise Silencing	67-69	Series-Parallel Resistances	181
Oscillator Circuits	60-61	Series Power Supplies	24
Performance	137	Series Resistances	30
Portable	268	Series Resonance	435
Power Supply	190	Servicing Receivers	128, 130, 131, 135-137
Pre-Selection	64, 125-127	Sheet Metal Working	107
Protection from Transmitter	272	Shenandoah	12
Quartz Crystal I.F. Filters	64-66	Shielding	55-56
R. F. Amplifiers	54-57, 129-130	Shields, Electrostatic	219
Regeneration Control	130	Short Wave Receivers (see "Receivers")	
Regenerative Detector Circuits	51-52	Shot Noise	67
Regenerative I.F. Amplifiers	117-121, 133		

	PAGE
Side Bands	89-90
Signal Generators	258-259
Signal-Noise Ratio	55, 57-58
Signal-Strength Indicators	69-70
Signal-Strength Scale	439
Silencers, Noise	67-69
Sine Wave	28
Single-Signal Reception	132-133
Skip Distance	15, 16
Sky Wave	15, 16
Smoothing Choke	179
Socket Connections	284-288
Solar Cycle	15
Soldering	108
Space Charge	26, 39
Speech Amplifiers	191-198
Speech Amplifier Design	101-103
Speech Amplifier Design Chart	94-95
Squegging	61, 129
Stability, Receiver	48-49, 60-61, 137
Stability, Transmitter	72, 211
Standards, Frequency	250-253
Standing Waves	32, 326
Static Characteristics	39-40
Static Charge	2
Station Arrangement	270-271
Station Control System	271-272
Station License	20-21
Steatite	26
Storage Batteries	25, 263-264
Stub Antenna Matching	332-333
Sulphur	26
Sunspot Cycle	15
Super-Control Tubes	47
Superheterodyne Receivers (see "Receivers")	
Superimposed Currents	36
Superregeneration	45-46
Superregenerative Receivers	374-375
Suppressor Grid	46
Suppressor-Grid Keying	224
Suppressor-Grid Modulation	92, 242
Suppressor, Noise	68
Surge Impedance	34
Swinging Choke	174, 178
Switching, Antenna	273-274
Switching, Control System	281-282
Switching, Receivers	52-53
Switching, Transmitter	87
Symbols, Electrical	280-281
Symbols, Schematic	281
Synchronization	29-30
Tables and Charts (see "Charts and Tables")	
Tables, Operating	270
Tank Circuits	71, 80
Tap Sizes	107
Tapped Circuits	35
Terminated Line	34
Test Equipment	128, 255-262
Test Oscillators	254-255, 258-259
Tetrode Amplifiers	77
Tetrode Crystal Oscillator	73, 210
Tetrodes	46
Thermal Agitation	57
Thermionic Conduction	25-26
Thermionic Emission	26
Threads, Cutting	106-107
Threshold Control	69
Thump Filters	226-228
Television	363
Time Constant	64, 278
Tone Control	54, 137
Tools	104
Tourmaline	32
Tracking	57, 61-62, 135
Transatlantic Tests	10
Transceivers	16, 393-401
Transconductance (Mutual)	39
Transformer	28
Transformer Coupling	35, 101
Transformers, I.F.	62-63
Transmission Lines (see "Antennas")	
Transmitters:	
Antenna Coupling	170-173, 331-332, 336-337
Band-Switching	87
Bias Supplies	184-186
Blocking and By-Pass Condensers	71, 82
Cathode Bias	42
Center-Tap	71
Condensers, Voltage Rating	81, 82

Constructional:		
Complete Transmitter Assemblies:		
150-Watt Grid-Modulated 'Phone	205	
200-250-Watt 'Phone-C.W. Transmitter	207	
300-Watt 'Phone-C.W. Transmitter	206	
450-Watt C.W. Transmitter	205	
1-Kw. 'Phone-C.W. Transmitter	208	
Exciters or Low-Power Transmitters:		
15-Watt Output 6L6G Oscillator	138-139	
20-Watt Output 6L6 Osc.-Transmitter	139-141	
20-Watt Output E.C.O. Exciter	144-149	
40-Watt Output 6L6-6L6 Transmitter	141-144	
50-Watt Output 6L6-807 Exciter	149-152	
50-Watt Output Band-Switching Exciter	152-155	
100-175-Watt Output 6L6-6L6-HY51Z Transmitter	155-157	
200-Watt Output 6V6-807-75T Transmitter	157-163	
Power Amplifiers:		
450-Watt Input Push-Pull Amplifier	163-165	
450-Watt Input Band-Switching Amp.	165-168	
1-Kilowatt Input Push-Pull Amplifier	168-170	
Crystal Control		73-75
Crystals, Mounting		75
E.C.O. Exciter		144-149
Efficiency		72, 84
Electron-Coupled Circuit		72
Excitation		72, 82-84
Exciters		87
Filament Center-Tap		71
Frequency Modulation (see "Frequency Modulation")		
Frequency Multipliers		71, 85-86
Frequency Stability		72
Grid-Bias		42, 84
Grid Neutralization		78
Grid-Plate Oscillator		75
Grounds		37, 187
Harmonic Generation		74, 80
Harmonic Suppression		218-219
Inductance Tables		81, 83
Interstage Coupling		76-77
L-C Ratios		32
Link Coupling		77
Load Impedance		85
Metering		87, 206-209
Neutralization		78-80
Oscillator Circuits		72-75
Output Coupling		85
Parallel Feed		71
Parasitic Oscillations		72
Pentode Crystal Oscillators		74-75
'Phone (see "Radiotelephony")		
Pierce Oscillator		74
Plate Neutralization		78
Portable (see "Portable")		
Power Amplifiers		71, 76
Power Supply (see "Power Supply")		
Push-Pull Operation		78
Rack Construction		202-206
Self-Controlled Oscillator Circuits		72
Series Feed		71
Tank Circuits		71, 80
Tank Impedance		80-81
Tetrode Crystal Oscillators		73
Triode Crystal Oscillators		73
Tri-Tet Circuit		74-75
Tubes		86
Tubes (Tables of Characteristics)		
Tuning		210-211, 212-220
Ultra-High Frequency (see "Ultra-High Frequency")		
Wiring		108
Transceivers		393-401
Transmitters:		
224 & 112 Mc. HY-615 Linear Oscillator	389-390	
224 & 112 Mc. P.P. HY-615 Oscillator	390-392	
112-Mc. 7A4 "Pot" Oscillator	387-389	
112-Mc. P.P. T-40 Linear Oscillator	392-393	
112-Mc. Battery Transceiver	394-399	
112-Mc. 1.4-volt Transmitter-Receiver	399-401	
56 and 112 Mc. 815 Amplifier	386-387	
56-Mc. Battery Portable Trans.-Rec.	393-394	
56-Mc. 89-807 Mobile Unit	384-386	
56 & 28 Mc. 6L6-807-HK24 Exciter	380-382	
56 & 28 Mc. 6E6 Compact Transmitter	383-384	
56 & 28 Mc. P.P. 812 Amplifier	382-383	
Trapezoidal Pattern	234-238	
Trimming Condenser	57	
Triode	39	
Triode Crystal Oscillators	73, 210	
Tri-Tet Oscillator	74, 210-211	
Trouble Shooting (Receivers)	128, 130-131, 135-137	

Index

	PAGE		PAGE
Tube Conversion Factors (Chart)	282	Rectifiers	38
Tube Noise	57	Socket Connections	284-288
Tubes (see "Vacuum Tubes")		Space Charge	26, 39
Tuned Circuits	31	Symbols	281-282
Tuned R.F. Receiver	58	Tables:	
Tuning Indicators	69-70	Cathode-Ray Tubes	301-302
Tuning Receivers	128-134	Control and Regulator Tubes	301
Tuning Transmitters	210-211, 212-220	Receiving	289-300
Turns Ratio	35, 54	Rectifiers	303-304
Twisted Pair Line	325, 329-330	Transmitting	305-316
		Transmitting (Television)	317
Ultra-High Frequencies:		Tetrodes	46
Antenna Systems	363, 415-420	Transmitting	86-87
Converters, U.H.F. Frequency	365-372	Variable- μ Tubes	47
DX	363	Variable Selectivity	66
Development	11-12	Velocity Microphone	100
Direct-Ray Transmission	362	Velocity of Radio Waves	32
E-Layer Transmission	362-363	Vibrator Supplies (Table)	265
Equipment	363	Vibrator-Transformers	264-266
Frequency Modulation	363, 402-414	Volt	23
Linear Oscillator Circuits	389-393	Voltage	23
Lower-Atmosphere Transmission	363	Voltage Amplification	41
Performance	16, 362-363	Voltage Dividers	50, 188-190
Pot Oscillator	387-389	Voltage Feed for Antennas	325
R.F. Amplifiers	378-379	Voltage Ratio	35
Receivers:		Voltage-Regulated Power Supplies	181-183
General	364-365	Voltage Regulation	170, 181-183, 184-186
112-Mc. Acorn-Tube Self-Quenched Receiver	376-377	Voltmeters	255-257
112-Mc. Compact Self-Quenched Receiver	375-376	Volunteer Code Practice Stations (for Beginners)	19
112- & 56-Mc. Converter	365-369	W1AW-WLMK, A.R.R.L. Hq. Station. <i>Frontispiece</i> , 13-14	
56-Mc. Converter with R.F. Amplifier	369-370	WIIF	13
56-Mc. Superheterodyne	372-374	WIMK	13
56 & 28 Mc. Mobile Converter	365-369	WAC Certificates	11, 14
Three-Band Separately-Quenched Receiver	377-378	WAS Certificates	436
T.R.F. Superregenerative Receivers	378-379	WWV Schedules	262
Superregenerative Receivers	374-375	Warner, Kenneth B.	10-11
Television	363	Watt	26
Antennas	344-345	Wavelength	32
V-Cut Crystals	75	Wavelength-Frequency Conversion	32
Vacuum Tube Voltmeters	257-258	Wavelength Performance	15-16
Vacuum Tubes:		Wavelengths, Amateur	16
Beam Tubes	46	Wavemeter (see "Frequency Meters and Monitors")	
Cathodes	26, 47	Wave Traps	229
Characteristic Curves	38-40	Windchargers	267
Conversion Factors (Chart)	282	Wire Table	283
Emission	25-26	Wiring	107-108
Multi-Purpose Tubes	47	Wiring, Current Capacity	285
Operation:		Wiring Diagrams	37
As Amplifiers	39-42	Word Lists for Accurate Transmission	425
Class A	42	Workbench	105
Class B	42-43	Workshop Practice	104-108
Class C	43	X-Cut Crystals	75
Other Classifications	43-44	Y-Cut Crystals	75
As Detectors	38-39	Zero Beat	129
As Oscillators	44-46	Zepp Feed for Antennas	334
Pentodes	46-47	Zinc	24
Ratings and Characteristics	289-317		